

Катодним темплатним методом на пінонікелевих основах синтезовані електродні матеріали для позитивного електрода гібридного суперконденсатору. Знайдено оптимальний час осадження – 10 і 20 хвилин. Показано, що ємкість при такому способі нанесення складається з двох компонентів – ємкості композитного ПВС-Ni(OH)₂ матеріалу і ємкості пінонікелевої основи. Максимальна питома ємкість електродів, отримана при густині струму 320 mA/cm², складає 2,26 Ф/см²

Ключові слова: гідроксид нікелю, Ni(OH)₂, суперконденсатор, електроосадження, катодний темплатний синтез, полівініловий спирт, розрядна ємкість

Катодным темплатным методом на пеноникелевых основах синтезованы электродные материалы для положительного электрода гибридного суперконденсатора. Найдено оптимальное время осаждения – 10 и 20 минут. Показано, что емкость при таком способе нанесения состоит из двух компонентов – емкости композитного ПВС-Ni(OH)₂ материала и ёмкости пеноникелевой основы. Максимальная удельная емкость электродов, полученная при плотности тока 320 mA/cm², составляет 2,26 Ф/см²

Ключевые слова: гидроксид никеля, Ni(OH)₂, суперконденсатор, электроосаждение, катодный темплатный синтез, поливиниловый спирт, разрядная емкость

THE PROPERTIES INVESTIGATION OF THE FARADAIC SUPERCAPACITOR ELECTRODE FORMED ON FOAMED NICKEL SUBSTRATE WITH POLY-VINYL ALCOHOL USING

V. Kotok

PhD, Associate Professor**

Department of Processes, Apparatus and General Chemical Technology*

E-mail: valeriykotok@gmail.com

V. Kovalenko

PhD, Associate Professor**

Department of Analytical Chemistry and Food Additives and Cosmetics*

E-mail: vadimchem@gmail.com

*Ukrainian State University of Chemical Technology
Gagarina ave., 8, Dnipro, Ukraine, 49005

**Department of Technologies of Inorganic Substances
and Electrochemical Manufacturing

Federal State Educational Institution of Higher Education
"Vyatka State University"

Moskovskaya str., 36, Kirov, Russian Federation, 610000

1. Introduction

Nickel (II) hydroxide is used as an active material of positive electrode in accumulators [1, 2]. This compound also finds applications in other fields: oxidation of organic compounds [3], sensors [4] and as electrochromic material [5, 6]. Nonetheless, the field of nickel hydroxide application is constantly growing. Lately, the nickel oxide films [7, 8] have been viewed as components for dye-sensitized solar cell. Nickel oxide is usually prepared by calcination of nickel hydroxide that had been prepared by various methods. Such application of nickel-based oxide-hydroxide materials is related to the formation of nickel oxide and nickel oxyhydroxide, which is formed by oxidation of nickel hydroxide, both of which are p-type semiconductors.

Because of a growing number of applications for nickel oxide-hydroxide materials, the relevance of its research continues to be constantly high. The latter is proven not only by a large number of applied papers in various fields of nickel hydroxide application [9, 10], but by a significant number of theoretical papers as well [11, 12]. Theoretical works on Ni(OH)₂ summarize the newest information re-

garding the compound or recent progress on its synthesis and application [13, 14].

The electrochemical precipitation stands out among a variety of Ni(OH)₂ synthesis methods. Thus, the work [15] describes one of synthesis methods for preparation of nickel hydroxide thin films for application in electrochromic devices. The film prepared by the cathodic template method is a composite and consists of a matrix – the polyvinyl alcohol and nickel hydroxide. Such a film is similar in structure to the films prepared in the works [16, 17]. Deposition using cathodic template methods allows for deposition of films with good electrochemical and electrochromic properties, required uniformity and strong adhesion to the substrate. The film formation occurs according to reactions 1 and 2:



It should be noted that strong adhesion and reliable contact of the active material with the electrode (current collector) is one of the main requirements for active material for

chemical power sources, especially at high charge-discharge rates [18]. Fulfilling this requirement enables the creation of rechargeable power sources with high durability [19, 20].

It can be summarized that cathodic template deposition method can be used for the preparation of electrodes with high specific characteristics and long life cycle.

It should be noted that polyvinyl alcohol is widely used for the preparation of composite materials for electrochemical supercapacitors [21], and as a surfactant during synthesis [22]. Additionally, the polyvinyl alcohol is commonly used for the preparation of flexible supercapacitor electrodes [23, 24]. Use of PVA for template synthesis should allow for preparation of highly active thin film Faradic electrode for hybrid supercapacitor. Thus, the study on such Faradic electrode is relevant.

2. Literature review and problem statement

Development and further industrial production of power sources with high specific characteristics, asymmetric supercapacitors, in particular, are only possible if an active material with required characteristics is available. The active material should exhibit sufficiently high electrochemical activity and high specific surface area [25, 26]. The active material need also to form a good contact with the electrode surface, so it wouldn't peel off at high charge-discharge rates [18]. This is because at the high charge-discharge rate the undesirable processes, such as gas evolution due to electrolyte decomposition, are more pronounced at high charge-discharge rates [27]. This can lead to reduced contact surface between the material and current collector due to material peeling off, resulting in a decrease of the overall capacity of the electrode. In addition, the charge-discharge process can lead to changes in the crystal lattice of the active material [28, 29], which would lead to a change in the material's volume causing active material to peel off. Both described mechanisms for capacity loss manifest in various power sources. To eliminate these mechanisms, various additives that increase the polarization of unwanted processes and various binders are used [30, 31].

There are a few types of electrodes that are used for chemical power sources, which can be split into three groups: pasted, box and formed. The electrodes of the latter type are formed onto the current collector as a result of chemical or electrochemical reactions. This type of electrodes has the advantage of the simple production chain due to lack of operations required during manufacturing of other electrode types. This approach results in the electrode that is ready for immediate use. Electrodes of this type find their use in the production of alkali batteries, where the sintered nickel matrix is impregnated with solutions of nickel sulfate and base for the formation of Ni(OH)_2 layer.

Cathodic template method for Ni(OH)_2 deposition has all the necessary prerequisites for use in preparation of electrode materials for hybrid supercapacitors [15]. This method allows for the preparation of a thin uniform film that is strongly bound to the substrate, with the resulting electrode being ready for immediate use. This method also allows for the single stage formation of supported active material films, which potentially can decrease the cost of the final product. Formation of nickel hydroxide thin films with a lot of defects and structure water, using the cathodic template method [5, 6] would lead to the high activity of the resulting mate-

rial. Considering that research regarding the use of cathodic template synthesis for the formation of hybrid supercapacitor electrodes has not been conducted previously, the authors have decided to evaluate the specific characteristics of the material prepared with this method.

3. The aim and objectives of the study

The aim of the work is to evaluate the possibility of preparing composite materials based on nickel hydroxide for positive supercapacitor electrodes using the cathodic template method.

For achievement of the set aim, the following objectives must be completed:

- to deposit composite nickel hydroxide films using the cathodic template synthesis at different deposition time;
- to evaluate the structure and morphology of prepared films;
- to determine specific capacities of prepared films.

4. Film deposition and characterization methods

The deposition regimes [15] listed in Table 1 were used in all experiments. For nickel hydroxide film deposition, a two-compartment cell with a low-permeability membrane was used. $\text{Ni(NO}_3)_2$ solution was used in the cathodic space; anodic – KNO_3 .

Table 1

Electrolyte deposition regimes and composition for cathodic template deposition onto nickel foam

Sample* (name)	C (Ni^{2+}), cathodic chamber M/L	PVA concentration, %	Deposition current density, mA/cm^2	Deposition time, min	Drying temperature, °C
Ni-PVA5	1	5	0.625	5	20
Ni-PVA10	1	5	0.625	10	20
Ni-PVA20	1	5	0.625	20	20
Ni-PVA40	1	5	0.625	40	20
Ni-PVA80	1	5	0.625	80	20

Note: * – 1M 1M KNO_3 was used in the anodic chamber

Rectangular pieces of 300 PPI nickel foam (Russian Federation), 0.5 cm^2 were used as a substrate. Nickel stripes were spot-welded to nickel foam pieces for current supply.

After deposition of Ni(OH)_2 , the electrodes were placed into room-temperature distilled water for an hour in order to remove excess polyvinyl alcohol. The electrodes were dried at room temperature for 24 hours.

Additionally, the capacities of the samples were also obtained, preparation conditions for which are listed in Table 2.

In order to evaluate capacitive characteristics, the charge-discharge cycling method was used. The charge-discharge measurements were recorded on the digital potentiostat-galvanostat Ellins P-8 (Russian Federation) using the cell depicted in Fig. 1. Ag/AgCl (KCl sat.) was used as a reference electrode. Nickel mesh with a surface larger than the working electrode was used as a counter-electrode. 6M KOH solution was used as an electrolyte in all experiments.

The charge-discharge cycling was conducted at the following current densities: 20, 40, 80, 160, 320 mA/cm². Charge and discharge current densities were the same during cycling. The current values were calculated according to the electrode area – 0.5 cm². The specific capacities for all samples were calculated for each discharge current density.

Table 2
Treatment regimes for nickel foam electrodes

Sample (name)	Current density, mA/cm ²	Soaking time, min	Cathodic chamber electrolyte	Anodic chamber electrolyte
10KNO ₃	0.625	10	1M KNO ₃ + 5 % PVA (instead of Ni(NO ₃) ₂)	1M KNO ₃
20KNO ₃	0.625	20		
10KNO ₃ no current	0	10		
20KNO ₃ no current	0	20		

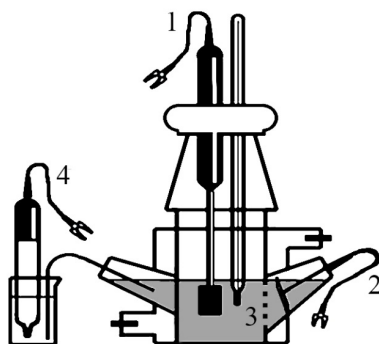

Fig. 1. Cell for charge-discharge measurements: 1 – working electrode; 2 – counter-electrode; 3 – electrolyte; 4 – reference electrode.

The electrodes were cycled 10 times at each current density and average specific capacity was calculated. The specific capacities were calculated using two methods: using the time between the start and the finish of Ni(OH)₂ discharge plateau and using the time between the start of discharge plateau and the start of hydrogen evolution (Fig. 2).

The specific capacities were calculated using the following formula (3):

$$C = (I\tau) / (\Delta E \cdot S), \text{ F/cm}^2, \quad (3)$$

where I – discharge current, mA; τ – discharge time (Fig. 2), s; ΔE – potential difference (Fig. 2), V; S – electrode working area, cm² (0.5 cm²).

Thus, two capacities were obtained: C_p (calculated from ΔE_p and τ_p) and C_H (calculated from ΔE_H and τ_H) (Fig. 2). The electrode working area was used instead of the active material mass in formula (3), because of the low mass gain (0.1–0.3 milligrams), which did not allow for accurate calculations of specific capacities by the weight of active material.

In order to determine the structure of prepared materials, the XRD patterns of films on nickel foam substrates were recorded, using the DRON-3 diffractometer (Russian Federation), Co-K α monochromatic radiation.

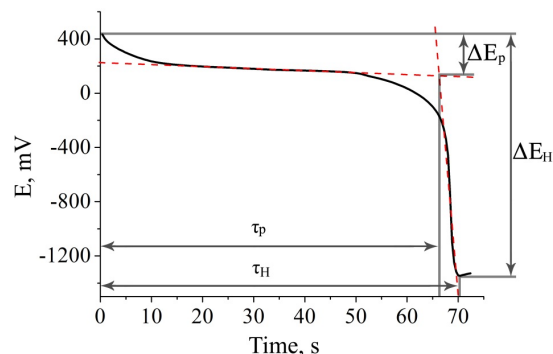

Fig. 2. Methodology for choosing discharge times and potential differences

The morphology of the samples was evaluated by means of Scanning Electron Microscopy (SEM) using JEOL JSM-6510 LV (Japan).

Sample composition was evaluated by means of Energy Dispersive X-ray analysis (EDX), using JEOL JEM-2100 (Japan).

5. Results of electrodeposition experiments of PVA-Ni(OH)₂ films

As a result of cathodic template deposition, a few electrodes were prepared. The electrodes differed in a deposition time of PVA-Ni(OH)₂ composition material. Upon visual examination, the prepared electrodes were identical to the initial nickel foam, due to a small film thickness caused by a large area of nickel foam. The mass gains were less than a milligram, so the capacities calculated in cycling experiments were related to the electrode area (0.5 cm²). The unthreaded matrix was also subjected to cycling. This was done because the surface of nickel foam is covered with a layer of nickel oxides and hydroxides, which can contribute to the overall electrode capacity.

An additional series of experiments were also carried out, in which the nickel foam matrix was soaked in the solution of nickel nitrate and polyvinyl alcohol for 10 and 20 minutes, with and without cathodic polarization. This was done in order to evaluate the contribution of polyvinyl alcohol to the total electrode capacity.

5. 1. Analysis of structure, morphology and composition of PVA-Ni(OH)₂ films prepared by electrodeposition

In order to compare the structure of the deposited materials, the XRD patterns of all prepared films were recorded. The XRD patterns of the samples prepared on nickel foam for 5 and 80 min: are presented in Fig. 3.

The analysis of recorded patterns has revealed that prepared films do not show any pronounced peak and only peaks corresponding to nickel foam are observed. However, at low angles ($2\theta=5-15^\circ$) there is some signal increase, with prolonged deposition time (Fig. 3).

SEM images were recorded for all prepared electrode materials, in order to determine their morphology. SEM images of the samples prepared at the shortest and longest deposition times (Ni-PVA5 and Ni-PVA80 samples) are presented in Fig. 4.

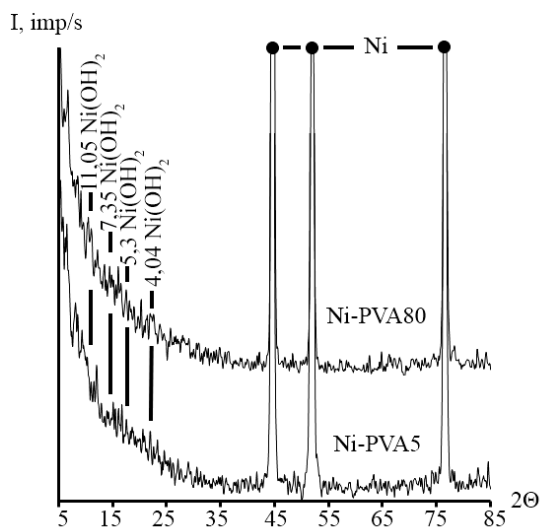

Fig. 3. XRD patterns of Ni-PVA5 and Ni-PVA80 samples

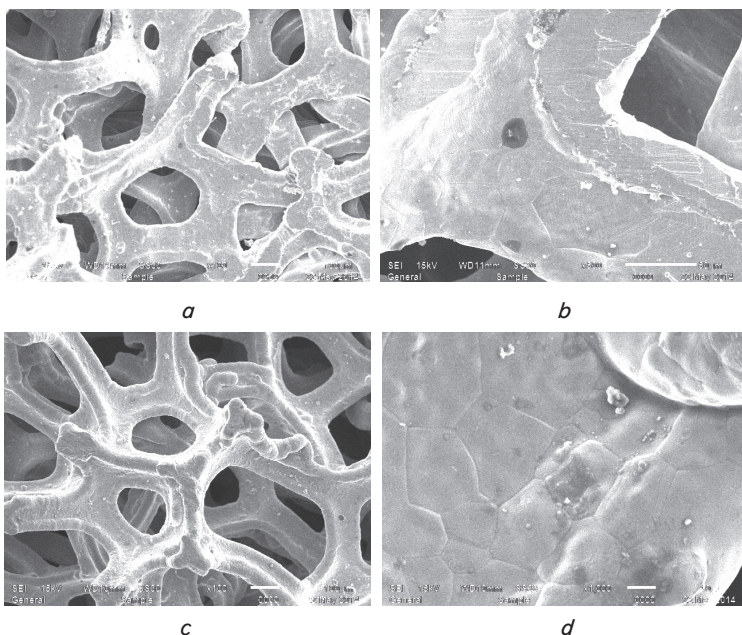

Fig. 4. SEM images for the electrodes prepared using cathodic template method at different deposition times: *a, b* – Ni-PVA5; *c, d* – Ni-PVA80

Upon thorough examination of the obtained images, film cracking and partial peeling can be observed in Fig. 4, *b* and Fig. 4, *d*. In order to confirm the presence of the composite film, the elemental composition of several film regions (Fig. 5) was determined, the results of which are compiled in Table 3.

Table 3

Elemental composition of the electrode prepared using cathodic template method (deposition time 80 min)

Element	Mass, %	Atomic, %
C	10.15	33.83
O	2.71	6.78
Ni	87.14	59.39

The analysis of the obtained values has revealed the presence of significant amounts of carbon and oxygen on the surface of nickel foam.

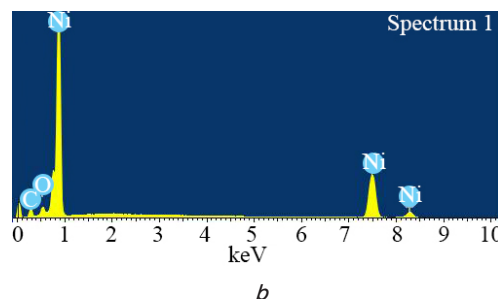
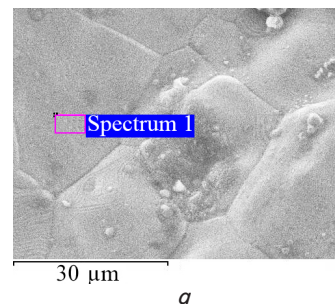

Fig. 5. EDX results for the Ni-PVA80 electrode, prepared using cathodic template method: *a* – image and probed region: violet rectangle; *b* – acquired spectra

5. 2. Comparison of electrochemical characteristics of the electrodes prepared using cathodic template method at different deposition times

The electrodes with the films deposited using cathodic template method were subjected to galvanostatic charge-discharge cycling (Fig. 6).

Two capacities were calculated from charge-discharge data according to the parameters presented in Fig. 2. The averaged values for different samples from different charge-discharge regimes are presented in Fig. 6, 7.

By analyzing the obtained histograms, a few facts can be stated:

- except for the Ni-PVA5 sample, the capacity of all samples either decreases or doesn't change with an increase of charge-discharge current density;
- the sample deposited for 10 minutes shows a sharp increase in capacity, with prolonged deposition time having a minimal impact on capacity;
- maximum capacities at the highest and lowest charge-discharge current densities were obtained for Ni-PVA10 and Ni-PVA20 samples, and are 2.7/0.88 F/cm² (at 20 mA/cm²) and 2.26/0.51 F/cm² (at 320 mA/cm²).

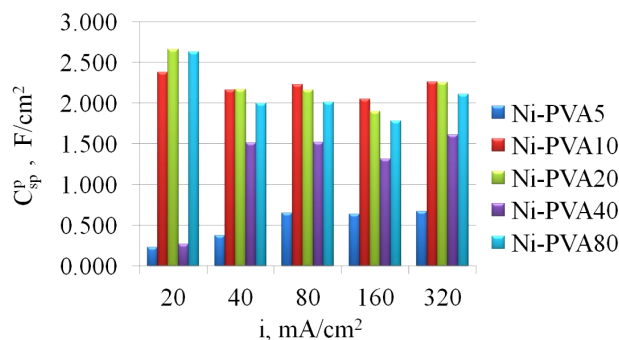

Fig. 6. Averaged specific capacities calculated from τ_p and ΔE_p for the samples prepared using cathodic template method

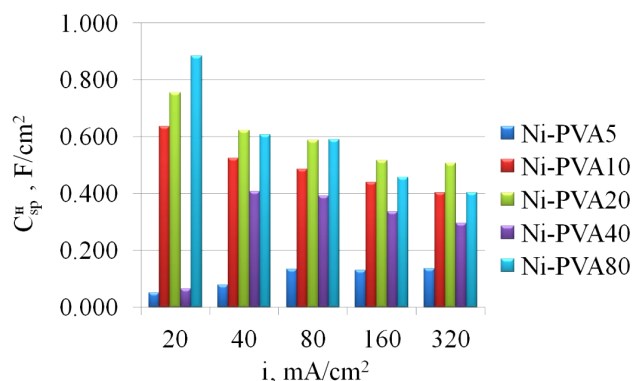

Fig. 7. Averaged specific capacities calculated from τ_H and ΔE_H for the samples prepared using cathodic template deposition method

5. 3. Comparison of electrochemical characteristics of nickel hydroxide films prepared by treating nickel foam in KNO_3

It is known that the surface of nickel is covered by the oxide-hydroxide layer. Therefore, the nickel foam matrix was subject to charge-discharge cycling, in order to evaluate its own capacity. Its discharge times were shorter than a second, with capacity being less than a tenth of 1 F/cm^2 . Nevertheless, in order to evaluate the influence of polyvinyl alcohol and cathodic polarization and their combined influence, an additional series of experiments had been conducted, the parameters of which are listed in Table 2. The obtained capacities for these samples are summarized in Fig. 8, 9.

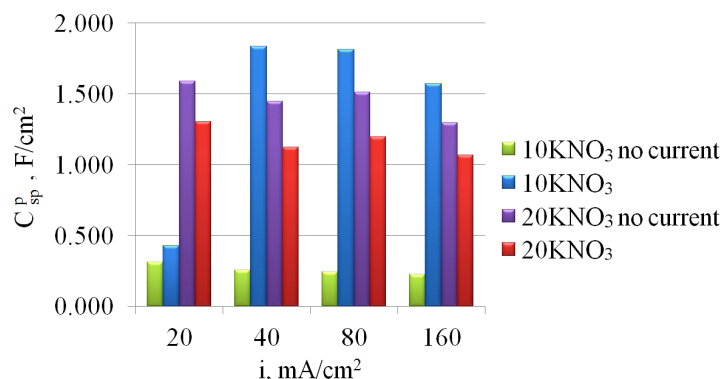

Fig. 8. Averaged specific capacities calculated from τ_p and ΔE_p for the samples treated with KNO_3

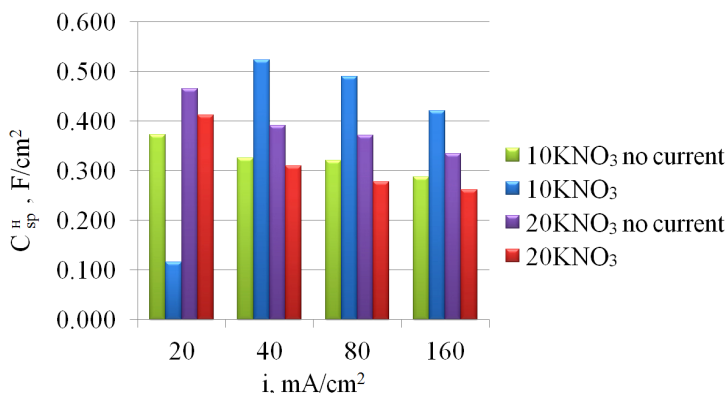

Fig. 9. Averaged specific capacities calculated from τ_H and ΔE_H for the samples treated with KNO_3

The acquired data and their analysis have allowed making a few conclusions regarding the soaking duration of nickel foams in potassium nitrate and polyvinyl alcohol solution with and without cathodic polarization. It would appear that the main effect is caused by soaking in KNO_3 and PVA solution, while cathodic polarization and soaking duration do not affect the electrode capacity significantly.

The maximum substrate capacities were obtained for the samples $20KNO_3$ with no current and $10KNO_3$, and are $1.60/0.46 \text{ F/cm}^2$ and $1.58/0.42 \text{ F/cm}^2$ correspondingly.

6. Discussion of the results of studying the supercapacitor electrodes formed on the foamed nickel substrate

As a result of conducted experiments on the deposition of active material on nickel foam matrixes using cathodic template method, a series of electrodes had been prepared. The XRD analysis has revealed that composite films are almost X-ray amorphous, i. e. they have a low degree of crystallinity and a large number of defects. Additionally, the films show barely distinguishable peaks at low angles, which may indicate a phase similar to $Ni(OH)_2$. Such α -like hydroxide with a large number of defects would likely contain a large amount of crystal water.

The results of Scanning Electron Microscopy have revealed that prepared deposited films crack during drying, which can be observed at high magnification.

The EDX analysis revealed significant amounts of carbon and oxygen on the surface of nickel foam. These elements indicate the presence of a composite material that had been formed during cathodic template deposition. The carbon indicates the presence of polyvinyl alcohol, and oxygen indicates the presence of polyvinyl alcohol and the presence of hydroxide formed during cathodic polarization of the substrate.

The results of charge-discharge cycling of composite materials deposited on nickel substrates have revealed the presence of electrochemical activity of the formed electrodes. It is interesting to note that increasing deposition time from 5 to 10 min leads to a significant increase of specific capacity, but further increase of deposition time did not yield significant changes. This is related to some effective thickness of the films formed with such method that actually works. This thickness is determined by the specific surface area and proton diffusion coefficient. In case of deposition of $PVA-Ni(OH)_2$ composite films thicker than the effective thickness, the rest of the films doesn't partake in electrochemical processes. The maximum specific capacity values were obtained for Ni-PVA10 and Ni-PVA20 electrodes, which are $2.7/0.88 \text{ F/cm}^2$ (at 20 mA/cm^2) and $2.26/0.51 \text{ F/cm}^2$ (at 320 mA/cm^2).

It is interesting that the nickel foam substrate treated with KNO_3 solution also showed a notable electrochemical activity. Only soaking in PVA and KNO_3 solution resulted in a notable increase of specific capacity. The treatment was the only determining factor, and not its duration or cathodic polarization. Based on this fact, it was concluded that the result was caused by a polyvinyl alcohol film on the surface of nickel foam. Presumably, the operation mechanism

consists in a significant increase of polarization of oxygen evolution, which is a side process that lowers the charge efficiency of nickel hydroxide. Herewith, the oxides and hydroxides on the surface of nickel foam work more effectively.

It can be concluded that specific capacity of the electrodes prepared by the cathodic template method is constituted by two components: the own capacity of the treated substrates and the capacity of the deposited PVA-Ni(OH)₂ composite.

7. Conclusions

1. The possibility of preparing composite materials for positive electrodes of hybrid supercapacitors using cathodic template method has been demonstrated. The formed

electrodes have a flat morphology with a grid of cracks and consist of a composite PVA film and X-ray amorphous α -like nickel hydroxide.

2. The specific capacitive characteristics of prepared composite films and treated substrates have been determined. The maximum capacities were obtained for Ni-PVA10 and Ni-PVA20 samples and are 2.7/0.88 F/cm² (at 20 mA/cm²) and 2.26/0.51 F/cm² (at 320 mA/cm²), the maximum capacities for the treated substrates were demonstrated by the samples 20KNO₃ with no current and 10KNO₃ – 1.60/0.46 F/cm² (at 20 mA/cm²) and 1.58/0.42 F/cm² (at 160 mA/cm²) correspondingly.

3. It had been demonstrated that the resulting specific capacity is constituted by two components: the own capacity of the treated substrate and the capacity of the deposited PVA-Ni(OH)₂ composite.

References

1. Kovalenko, V. Definition of factors influencing on Ni(OH)₂ electrochemical characteristics for supercapacitors [Text] / V. Kovalenko, V. Kotok, A. Bolotin // Eastern-European Journal of Enterprise Technologies – 2016. – Vol. 5, Issue 6 (83). – P. 17–22. doi: 10.15587/1729-4061.2016.79406
2. Kovalenko, V. L. Nickel hydroxide obtained by high-temperature two-step synthesis as an effective material for supercapacitor applications [Text] / V. L. Kovalenko, V. A. Kotok, A. A. Sykchin, I. A. Mudryi, B. A. Ananchenko, A. A. Burkov et. al. // Journal of Solid State Electrochemistry. – 2017. – Vol. 21. – P. 683–691. doi: 10.1007/s10008-016-3405-2
3. Solovov, V. Influence of temperature on the characteristics of Ni(II), Ti(IV) layered double hydroxides synthesised by different methods [Text] / V. Solovov, V. Kovalenko, N. Nikolenko, V. Kotok, E. Vlasova // Eastern-European Journal of Enterprise Technologies. – 2017. – Vol. 1, Issue 6 (85). – P. 16–22. doi: 10.15587/1729-4061.2017.90873
4. Miao, F. Ordered-standing nickel hydroxide microchannel arrays: Synthesis and application for highly sensitive non-enzymatic glucose sensors [Text] / F. Miao, B. Tao, P.K. Chu // Microelectronic Engineering. – 2015. – Vol. 133. – P. 11–15. doi: 10.1016/j.mee.2014.11.005
5. Kotok, V. The electrochemical cathodic template synthesis of nickel hydroxide thin films for electrochromic devices: Role of temperature [Text] / V. Kotok, V. Kovalenko // Eastern-European Journal of Enterprise Technologies. – 2017. – Vol. 2, Issue 11(86). – P. 28–34. doi: 10.15587/1729-4061.2017.97371
6. Kotok, V. Electrochromism of Ni(OH)₂ films obtained by cathode template method with addition of Al, Zn, Co ions [Text] / V. Kotok, V. Kovalenko // Eastern-European Journal of Enterprise Technologies. – 2017 – Vol. 3, Issue 12 (87). – P. 38–43. doi: 10.15587/1729-4061.2017.103010
7. Ranganathan, P. Enhanced photovoltaic performance of dye-sensitized solar cells based on nickel oxide supported on nitrogen-doped graphene nanocomposite as a photoanode [Text] / P. Ranganathan, R. Sasikumar, S.-M. Chen, S.-P. Rwei, P. Sireesha // Journal of Colloid and Interface Science. – 2017. – Vol. 504. – P. 570–578. doi: 10.1016/j.jcis.2017.06.012
8. Huo, J. Fabrication a thin nickel oxide layer on photoanodes for control of charge recombination in dye-sensitized solar cells [Text] / J. Huo, Y. Tu, M. Zheng, J. Wu // Journal of Solid State Electrochemistry. – 2017. – Vol. 21, Issue 6. – P. 1523–1531. doi: 10.1007/s10008-017-3515-5
9. Malara, F. A Flexible Electrode Based on Al-Doped Nickel Hydroxide Wrapped around a Carbon Nanotube Forest for Efficient Oxygen Evolution [Text] / F. Malara, S. Carallo, E. Rotunno, L. Lazzarini, E. Piperopoulos, C. Milone, A. Naldoni // ACS Catal. – 2017. – Vol. 7, Issue 7. – P. 4786–4795. doi: 10.1021/acscatal.7b01188
10. Qiu, C. Corrosion resistance and micro-tribological properties of nickel hydroxide-graphene oxide composite coating [Text] / C. Qiu, D. Liu, K. Jin, L. Fang, T. Sha // Diamond and Related Materials. – 2017. – Vol. 76. – P. 150–156. doi: 10.1016/j.diamond.2017.04.015
11. Hall, D. S. Nickel hydroxides and related materials: a review of their structures, synthesis and properties [Text] / D. S. Hall, D. J. Lockwood, C. Bock, B. R. MacDougall // Proceedings of the Royal Society A: Mathematical, Physical and Engineering Sciences. – 2015. – Vol. 471, Issue 2174. – P. 20140792. doi: 10.1098/rspa.2014.0792
12. Vidotti, M. Eletrodos modificados por hidróxido de níquel: um estudo de revisão sobre suas propriedades estruturais e eletroquímicas visando suas aplicações em eletrocatalise, eletrocromismo e baterias secundárias [Text] / M. Vidotti, R. Torresi, S. I. Córdoba de Torresi // Química Nova. – 2010. – Vol. 33, Issue 10. – P. 2176–2186. doi: 10.1590/s0100-40422010001000030
13. Yan-wei, L. Progress in research on amorphous nickel hydroxide electrode materials [Text] / L. Yan-wei, L. Chang-jiu, Y. Jinhuan // Xiandai Huagong/Modern Chemical Industry. – 2010. – Vol. 30, Issue 2. – P. 25–27.
14. Feng, L. Recent progress in nickel based materials for high performance pseudocapacitor electrodes [Text] / L. Feng, Y. Zhu, H. Ding, C. Ni // Journal of Power Sources. – 2014. – Vol. 267. – P. 430–444. doi: 10.1016/j.jpowsour.2014.05.092
15. Kotok, V. A. Advanced electrochromic Ni(OH)₂/PVA films formed by electrochemical template synthesis [Text] / V. A. Kotok, V. L. Kovalenko, P. V. Kovalenko, V. A. Solovov, S. Deabate, A. Mehdi, J. L. Bantignies, F. Henn // ARPN Journal of Engineering and Applied Sciences. – 2017. – Vol. 12, Issue 13. – P. 3962–3977

16. Vlasova, O. Research of the mechanism of formation and properties of tripolyphosphate coating on the steel basis [Text] / O. Vlasova, V. Kovalenko, V. Kotok, S. Vlasov // Eastern-European Journal of Enterprise Technologies. – 2016. – Vol. 5, Issue 5 (83). – P. 33–39. doi: 10.15587/1729-4061.2016.79559
17. Burmistr, M. V. Antifriction and Construction Materials Based on Modified Phenol-Formaldehyde Resins Reinforced with Mineral and Synthetic Fibrous Fillers [Text] / M. V. Burmistr, V. S. Boiko, E. O. Lipko, K. O. Gerasimenko, Yu. P. Gomza, R. L. Vesnin et. al. // Mechanics of Composite Materials. – 2014. – Vol. 50, Issue 2. – P. 213–222. doi: 10.1007/s11029-014-9408-0
18. Kotok, V. A. Optimization of nickel hydroxide electrode of the hybrid supercapacitor [Text] / V. A. Kotok, V. L. Kovalenko // Eastern-European Journal of Enterprise Technologies. – 2017. – Vol. 1, Issue 6 (85). – P. 4–9. doi: 10.15587/1729-4061.2017.90810
19. Wu, F. Polyacrylonitrile-polyvinylidene fluoride as high-performance composite binder for layered Li-rich oxides [Text] / F. Wu, W. Li, L. Chen, Y. Lu, Y. Su, W. Bao et. al. // Journal of Power Sources. – 2017. – Vol. 359. – P. 226–233. doi: 10.1016/j.jpowsour.2017.05.063
20. Lacey, M. J. A Robust, Water-Based, Functional Binder Framework for High-Energy Lithium-Sulfur Batteries [Text] / M. J. Lacey, V. Österlund, A. Bergfelt, F. Jeschull, T. Bowden, D. Brandell // ChemSusChem. – 2017. – Vol. 10, Issue 13. – P. 2758–2766. doi: 10.1002/cssc.201700743
21. Pawar, P. B. Graphene oxide – Polyvinyl alcohol nanocomposite based electrode material for supercapacitors [Text] / P. B. Pawar, S. Shukla, S. Saxena // Journal of Power Sources. – 2016. – Vol. 321. – P. 102–105. doi: 10.1016/j.jpowsour.2016.04.127
22. Shinde, S. K. Chemical synthesis of flower-like hybrid Cu(OH)/CuO electrode: Application of polyvinyl alcohol and triton X-100 to enhance supercapacitor performance [Text] / S. K. Shinde, V. J. Fulari, D.-Y. Kim, N. C. Maile, R. R. Koli, H. D. Dhaygude, G. S. Ghodake // Colloids and Surfaces B: Biointerfaces. – 2017. – Vol. 156. – P. 165–174.
23. Hu, R. Preparation of high strain polyaniline/polyvinyl alcohol composite and its applications in stretchable supercapacitor [Text] / R. Hu, J. Zhao, R. Jiang, J. Zheng // Journal of Materials Science: Materials in Electronics. – 2017. doi: 10.1007/s10854-017-7320-9
24. Xie, Y. Electrochemical capacitance performance of polyaniline/tin oxide nanorod array for supercapacitor [Text] / Y. Xie, F. Zhu // J Solid State Electrochem. – 2017. – Vol. 21, Issue 6. – P. 1675–1685. doi: 10.1007/s10008-017-3525-3
25. Zhu, Q. Design of a unique 3D-nanostructure to make MnO work as supercapacitor material in acid environment [Text] / Q. Zhu, K. Liu, J. Zhou, H. Hu, W. Chen, Y. Yu // Chemical Engineering Journal. – 2017. – Vol. 321. – P. 554–563. doi: 10.1016/j.ccej.2017.03.147
26. Tong, M. Two-dimensional CoNi nanoparticles@S,N-doped carbon composites derived from S,N-containing Co/Ni MOFs for high performance supercapacitors [Text] / M. Tong, S. Liu, X. Zhang, T. Wu, H. Zhang, G. Wang et. al. // J. Mater. Chem. A. – 2017. – Vol. 5, Issue 20. – P. 9873–9881.
27. Ataherian, F. Long-Term Charge/Discharge Cycling Stability of MnO₂ Aqueous Supercapacitor under Positive Polarization [Text] / F. Ataherian, N.-L. Wu // Journal of The Electrochemical Society. – 2011. – Vol. 158, Issue 4. – P. A422–A427. doi: 10.1149/1.3555469
28. Pan, G.-T. Electrodeposited Porous Mn_{1.5}Co_{1.5}O₄/Ni Composite Electrodes for High-Voltage Asymmetric Supercapacitors [Text] / G.-T. Pan, S. Chong, T. C.-K. Yang, C.-M. Huang // Materials. – 2017. – Vol. 10, Issue 4. – P. 370. doi: 10.3390/ma10040370
29. Zheng, J. ZnO nanoparticles anchored on nickel foam with graphene as morphology-controlling agent for high-performance lithium-ion battery anodes [Text] / J. Zheng, J. Lin, R. Chu, C. Wu, J. Zhang, Y. Chen, Y. Zhang, H. Guo // Journal of Applied Electrochemistry. – 2017. – Vol. 47, Issue 8. – P. 969–978. doi: 10.1007/s10800-017-1094-x
30. Chai, L. Chitosan, a new and environmental benign electrode binder for use with graphite anode in lithium-ion batteries [Text] / L. Chai, Q. Qu, L. Zhang, M. Shen, L. Zhang, H. Zheng // Electrochimica Acta. – 2013. – Vol. 105. – P. 378–383. doi: 10.1016/j.electacta.2013.05.009
31. Lin, C.-T. Multifunctional co-poly(amic acid): A new binder for Si-based micro-composite anode of lithium-ion battery [Text] / C.-T. Lin, T.-Y. Huang, J.-J. Huang, N.-L. Wu, M.-K. Leung // Journal of Power Sources. – 2016. – Vol. 330. – P. 246–252. doi: 10.1016/j.jpowsour.2016.09.021