

24. Bahatofunktionalnyi tablychno-lohichnyi spivprotseor: Pat. No. 111459 UA / Lukashenko V. A., Lukashenko D. A., Zubko I. A., Lukashenko A. H., Lukashenko V. M. No. a201509351; declared: 28.09.2015; published: 25.04.2016, Bul. No. 8.
25. Spivprotseor dlia obchyslennia znachen «priamykh» ta «obnerynykh» funktsiy: Pat. No. 111808 UA / Lukashenko A. H., Lukashenko V. M., Lukashenko D. A., Lukashenko V. A., Zubko I. A., Rudakov K. S. No. a201510690; declared: 02.11.2015; published: 10.06.2016, Bul. No. 11.
26. Tablychno-lohichnyi peretvoriuvach kodiv: Pat. No. 89784 UA / Chychuzhko M. V., Lukashenko V. A., Lukashenko D. A., Zubko I. A., Lukashenko V. M., Lukashenko A. H. No. u201315042; declared: 23.12.2013; published: 25.04.2014, Bul. No. 8.
27. Lukashenko V. A. Udoshkonalenyi tablychno-alhorytmichnyi metod i modeli aparaturnoi realizatsiyi pretsyziynykh obchysliuvachiv spetsialnoho pryznachennia: avtoref. dys. ... kand. tekhn. nauk. Cherkasy: ChDTU, 2016. 20 p.

Визначення показника для оцінки ефективності системних операцій є найважливішим етапом для оптимізації технологічних процесів будь-якого підприємства. Цей крок зумовлює сталій режим функціонування всіх його системних процесів.

Те, що всі без винятку технологічні процеси повинні бути оптимізовані з використанням узгодженого критерію оптимізації, є аксіомою. При цьому така можливість забезпечується тільки в одному випадку – якщо у всіх функціональних системах в якості критерію оптимізації використовується формула ефективності. Саме такий підхід забезпечує максимізацію фінансових можливостей власника підприємства.

Проблема полягає в тому, щоб серед безлічі оціночних показників, однакових за формальними ознаками, ідентифікувати таку структуру, яка відповідає структурі оригінальної формули ефективності.

Для практичного вирішення цього завдання в даний час визначені класи еталонних моделей операцій, кожен з яких має свою функціональну спрямованість. При цьому найбільш розробленими є класи еталонних моделей простих операцій.

По відношенню до класів еталонних моделей операцій з розподіленими параметрами, задача вирішена для операційних процесів з однаковою тривалістю в часі, а також для процесів, з різною тривалістю ресурсовіддачі по виходу.

У запропонованій роботі визначається обмежений клас моделей операцій з розподіленими параметрами різної тривалості по входу. Створення такого класу операцій є досить складним завданням, оскільки необхідно враховувати фактор часу і забезпечувати можливість зіставлення операційних процесів різної тривалості.

Для вирішення цього завдання, на першому етапі, були сформовані глобальні моделі простих операцій різної тривалості з визначеною рейтинговою ефективністю. На наступному етапі, шляхом композиції, формувалися еталонні моделі операцій з розподіленими параметрами щодо виходу різної тривалості.

Розвиток методу верифікації, за рахунок визначення класу операцій з розподіленими параметрами по входу різної тривалості у часі, істотно підвищує надійність і достовірність результатів верифікації оціночного показника. Процедурі верифікації необхідно проводити для критерію якщо передбачається його використовувати в якості показника ефективності

Ключові слова: верифікація оціночного показника, операція з розподіленими параметрами, клас операцій, метод верифікації

UDC 007.5

DOI: 10.15587/1729-4061.2018.142212

DEVELOPMENT OF TEST OPERATIONS OF DIFFERENT DURATION IN TERMS OF INPUT FOR THE VERIFICATION OF EFFICIENCY FORMULA

I. Lutsenko

Doctor of Technical Sciences, Professor
Department of Information and Control Systems*

E-mail: delo-do@i.ua

O. Fomovskaya

PhD, Associate Professor, Head of Department
Department of Electronic Devices*

O. Serdiuk

PhD, Senior Lecturer
Department of automation,
computer science and technology**

M. Baranovskaya

PhD, Associate Professor
Department of Electromechanics**

V. Fomovskiy

Lanzhou Jiaotong University
Anning West road, 88,
Lanzhou, P. R. China, 730070*Kremenchuk Mykhailo Ostrohradskiy
National University

Pershotravneva str., 20,

Kremenchuk, Ukraine, 39600

**Kryvyi Rih National University

Vitaliya Matusyevycha str., 11,

Kryvyi Rih, Ukraine, 50027

1. Introduction

A basis of the principle of operation of any enterprise is the execution of system operations. The task of system manage-

ment is to determine parameters of operations, which provide results of system functioning maximally coordinated with the purpose of its owner [1, 2]. In turn, the aim of an owner of an enterprise is to maximize its investment opportunities [3].

We need an indicator, which could play a role of a system optimization criterion to orientate operation of a managed system to maximization of investment opportunities of an owner.

We understand intuitively that such a criterion should reflect an objective cybernetic law. Researchers defined the law as a «resource use efficiency indicator» [4] or simply «an indicator of effectiveness».

After this time point, investigators divided tasks related to an efficiency indicator into two categories – tasks for development of an efficiency formula [5–7] and tasks for its verification: «Engineers, researchers, economists and designers continuously offer new» universal, accurate and clear» objective functions. In 1967, one of authors managed to collect over one hundred criteria for optimization of separation processes. After the classification, researchers found out that there is no universal criterion, and selection of an optimization criterion or a criterion of efficiency of a process is not a simple task» [8].

Obviously, there is only one best option among numerous alternative options for performance of operations. This means that a use of an arbitrarily chosen indicator as an efficiency formula leads to irreversible losses in growth rates of investment opportunities.

Therefore, it is necessary to verify one or another estimation indicator as an optimization criterion for adequacy with respect to the original efficiency formula before using it.

It is necessary that reference classes of identified models overlap a set of variable parameters of operations under investigation for reliable verification. Therefore, an extension of classes of reference models of operations is an important scientific task.

2. Literature review and problem statement

Numerous publications, studies and discussions related to development and use of an efficiency indicator prove the relevance of the topic of verification of indicators proposed by authors as an optimization criterion. In many respects this is because of lack of an established definition of «efficiency» category [9, 10]. Such situation leads to a use of a variety of technical and technical-and-economic indicators. Researchers try to make judgments about effectiveness of operational processes and to establish ratings for them using these indicators.

Lack of proper attention to reliability of results of identification of operations and results of optimization contributed to creation of a kind of «industry» for development of estimation indicators.

Thus, there is an attempt to rank efficiency of operations with a use of an «energy efficiency» indicator in paper [11]. Authors of work [12] associate «efficiency» with «reliability». Authors of paper [13] use a «filling criterion» to rank operations for the purpose of making a decision, and authors of a paper [14] – a «prediction error». Work [15] proposes to use a value of the minimum deviation from a given trajectory of motion as an optimization criterion, work [16] – a «global optimality criterion», and work [17] – to use «technical efficiency».

There is a continuous intensive research related to determination of energy efficiency [18]. The approach seems to be universal; however, such works do not take into account wear of a controlled system and a value of an output product of an operation.

Traditionally, there are a lot of published works where minimum of costs is an optimization criterion [19] or aggregation of costs with parameters obtained by scaling addi-

onal criteria [20]. As in the case with energy efficiency, expenses do not include wear costs, which leads to a shift in the extremum of an objective function from the point of minimum valuation of input products of an operation.

Paper [21] proposes to use a generalized indicator as an optimization criterion. We can form it with a use of extremums of significant integral indicators.

This approach leads to the synthesis of criteria with parameters with disparate units of measurement.

In work [22], selection of an operational process goes with a use of a technical- and-economic indicator. As in the case with generalized integral criteria, we can form such indicators are by aggregation of indicators with disparate parameters.

There are methods of proactive management used as one of the approaches to improvement of efficiency in paper [23]. It is obvious that the choice of a preemptive model, in turn, requires solution of the problem of structural optimization with a use of an efficiency criterion.

The presence of a large number of estimation indicators reflects lack of a systematic approach to development of optimization and verification criteria. On the other hand, the task of estimation of effectiveness of an operational process and verification of estimation indicators is a direct task of investigation of operations.

There was some progress in this direction after creation of a cybernetic model of a technological operation [24]. The next step was to determine formal features of an effectiveness formula [25] and a series of studies aimed at verification of evaluation indicators corresponding to characteristics [26–31].

Authors of work [26] established that we can represent a research model of any technological operation in the form of classified sets of input and output products (Fig. 1).

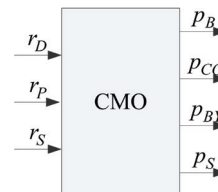

Fig. 1. Cybernetic single-product model of technological operation: CMO – cybernetic model of operation; r_D – product of a directed impact; r_P – energy product; r_S – input system product; p_B – main product; p_{CO} – accompanying product; p_{BY} – by-product; p_S – output system product

On the other hand, we can always transform a research model of an operation to the form of a global operation model in the form of a two or a triple [26] (Fig. 2).

The use of parameters-indicators of the global model of a simple operation gives possibility to make a judgment about rating effectiveness of operations in a number of cases [27].

We obtained such possibility as a result of definition of six classes of reference models of simple operations. The developed classes make possible to estimate sensitivity of indicators corresponding to changes in terms of input of an operation and in output of an operation, and relative capabilities of a verified indicator, to evaluate an influence of a time factor and prognostic capabilities.

Authors of paper [26] suggested a hypothesis that a formal sign of the efficiency formula for estimation of global operations with distributed parameters is a presence of second integrals of $re(t)$ and $pe(t)$ integral functions in the formula. Paper [28] proved this statement mathematically.

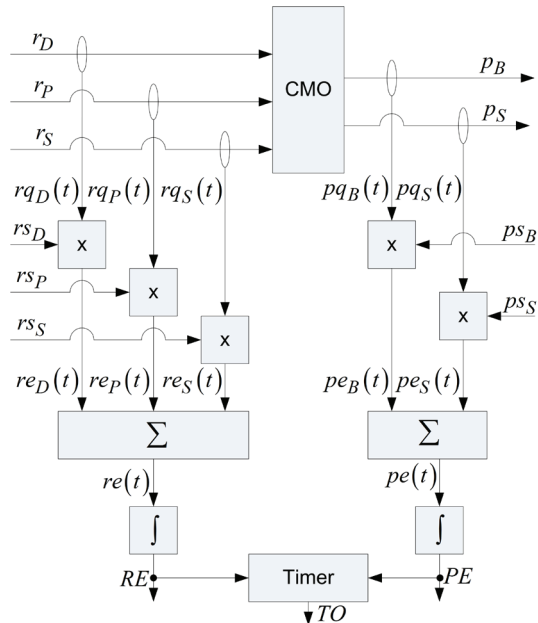

Fig. 2. Transformation of the data of the cybernetic operation model into the data of the global operation model: $rq_D(t)$ is the registration signal of a product of directed impact; $rq_P(t)$ is the registration signal of an energy product; $rq_S(t)$ is the registration signal of an input system product; $pq_B(t)$ is the registration signal of a main product; $pq_S(t)$ is the registration signal of an output system product; rs_D is the cost estimation of a product unit of a directed impact; rs_P is the cost estimation of a unit of energy product; rs_S is the cost estimation of a functional system; ps_B is the cost estimation of a unit of a main product; ps_S is the cost estimation of an output functional system; $re_D(t)$ is the reduced signal of registration of a product of a directed impact; $re_P(t)$ is the reduced signal of registration of an energy product; $re_S(t)$ is the reduced signal of registration of an input system product; $pe_B(t)$ is the reduced signal of registration of a main product; $pe_S(t)$ is the reduced signal of registration of an output system product; $re(t)$ is the reduced input function; $pe(t)$ is the reduced output function; RE is the integral estimation of input products of an operation; PE is the integral estimation of output products of an operation; TO is operation time

There is a class of reference models of operations with predetermined efficiency defined based on the study of synchronized models of operational processes in work [29]. And authors of work [30] determined limitations of the possibility to use direct methods for estimation of efficiency with a use of mathematical modeling techniques based on the results of the study.

Authors of paper [31] defined a class of reference models of operations with distributed parameters in output and with different duration in time.

In other words, now there is no class of reference operation models that give possibility to verify estimation indicators regarding their ability to identify operations with distributed parameters in terms of input and with different duration in time.

For example, the vast majority of logistics operations have a time-distributed character of movement of input products, and alternative logistic operations, as a rule, have different duration in time.

Therefore, definition of a class of reference models of operations with distributed parameters in terms of input of different duration is an important scientific task.

3. The aim and objectives of the study

The objective of the study is to define a reference class of global models of test operations with distributed parameters in terms of input of different duration for increasing accuracy of verification of an efficiency formula.

We set the following tasks to achieve the objective:

- to define rules for the formation of a limited class of global models of operations with distributed parameters by input and predetermined rating efficiency;
- to develop a method for the formation of a limited class of global models of operations with distributed parameters in terms of input of different duration and predetermined rating effectiveness;
- to conduct a test study of investigation of estimation indicator verified on previously developed classes of operation models using the developed class of models.

4. 1. Determination of operations with a discretely rationed character of distribution of products in terms of input

As we already noted, it is possible to represent any technological operation as a two ($re(t), pe(t)$) or a triple (RE, TO, PE).

The representation of an operation in the form of a triple (RE, TO, PE) is convenient because it is convenient to visualize such a global operation model by presentation of it in the form of a marked arrow-vector (Fig. 3).

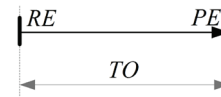

Fig. 3. Graphical representation of a simple global model of an operation under investigation

We consider format operations ($re(t), pe(t)$) as operations with discrete-rationed character of distribution of input and output products of the investigated operation of ($re[n], pe[n]$) type in this study.

We define operations with distributed parameters in terms of input among the class of operations models of ($re[n], pe[n]$) format. We assume that input products enter an entry of an operation not simultaneously in such models, and output products emerge at an output of an operation at discrete moments of time simultaneously. In this case, we can consider the operation with distributed parameters in terms of input as a model with a rationed supply of input products.

Fig. 4 shows the model with two-portioned supply of input products.

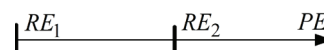

Fig. 4. A discrete operation model with a discrete-portioned character of distribution of its products in terms of input

The advantage of representation of an operation in a discrete-portioned form opens up the possibility of its decomposition into a set of simple operation models, and, accordingly, for performance of a composition operation.

The possibility of decomposition gives possibility to use the theoretical apparatus created for the study of simple models of global operations. After imposition of a number of restrictions on methods of composition, it becomes possible to create classes of reference models of operations with distributed parameters ranked according to their rating effectiveness.

Since we are talking about models with a discrete-portioned character of product distribution, we consider determination of t_x and n_x time moments as equivalent ones.

We define an operation with discretely distributed character of input products by composition of global models of simple operations of different duration synchronized at the moment of their completion. In this case, the expert estimation of an output product of an operation is equal to the sum of expert estimates of models of simple composition operations. Moments of time and values of expert estimates of input products correspond to time moments and values of corresponding input products of models of simple composition operations (Fig. 5).

We take the following statement as a postulate.

If the rating efficiency (RE) of each simple operation of A composition is not lower than any RE of any operation of B composition, and at least one of operations of A composition has higher RE comparing to at least one of operations of B composition, then RE of A composition is higher than RE of B composition.

We take the following initial data (RE, k, t_r, TO) to determine the rule for formation of models of operations with different RE .

Authors of work [29] established that a simple A operation with $RE_A=RE, TO_A=TO$ and $PE_A=kRE$ parameters is always less efficient than B operation with $RE_B=RE, TO_B=2 \cdot TO$ and $PE_B=k^2RE$ parameters. This is because of the fact that we cannot transfer an output product of A_1 operation to an entry of A_2 operation without additional costs ΔR (Fig. 6) within A_1A_2 operational process (Fig. 6).

However, since k^2RE result delivered by A_2 operation is equivalent to the result of B operation, then the efficiency of A_2 operation is higher than the efficiency of B operation. This statement follows logically from the fact that the efficiency of A_1 operation is less than the efficiency of B operation.

Since the effectiveness of A_1 operation is less than the efficiency of B operation, only more effective operation is able to provide the same result as for B operation at t_p time.

We can see from Fig. 6 that the value of the input product of A_2 operation is higher than the value of the output product of A_1 operation by an amount ΔR , despite the fact that they are equivalent algebraically.

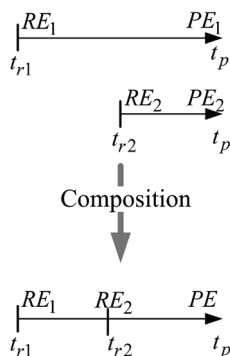

Fig. 5. Formation of a global operation model with distributed parameters in terms of input in the form of a composition with a use of two initial simple models of operations with different duration

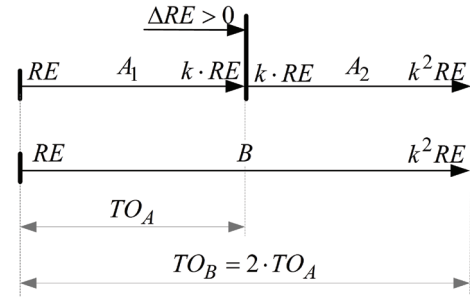

Fig. 6. Clarification of the reason for lower rating effectiveness of A_1 operation comparing with B operation

We define the rule for formation of operations of different duration with equal value estimates of output products and predefined rating efficiency for the case when operation time is a multiple of two. Formed operations end simultaneously.

We take the following data set (RE, k, t_r, TO) as the initial data. Table 1 presents the rules for formation of simple models of operations with a predetermined rating efficiency.

Table 1

Initial data and the rule for formation of models of simple operations of different duration with a predetermined efficiency

Initial data	Class of operations	Rating efficiency	Rule
RE, TO, k, t_r $\{RE; TO\} \in Q^+$ $k \in (1; 2]$	OPRE	2	$RE_A=RE, PE_A=k^3 \cdot RE,$ $t_{rA}=t_r, t_{pA}=t_r+2 \cdot TO$
		1	$RE_B=k \cdot RE, PE_B=k^3 \cdot RE,$ $t_{pB}=t_r+TO, t_{rB}=t_r+2TO$

Here, OPRE is the class of operations with predetermined rating efficiency.

Accordingly, it is possible to form C operation twice as long and less effective comparing to B operation, which ends simultaneously with it.

For operations A, B and C (Fig. 7), taking into account the notations of the initial data set, we obtain:

$$t_{rc}=t_r, RE_C=RE, TO_C=4TO, PE_C=k^3 \cdot RE;$$

$$t_{rB}=t_r+2 \cdot TO, RE_B=k \cdot RE, TO_B=2 \cdot TO, PE_B=k^3 \cdot RE;$$

$$t_{rA}=t_r+3 \cdot TO, RE_A=k^2 \cdot RE, TO_A=TO, PE_A=k^3 \cdot RE.$$

We use the possibility of composition and form two global models of the operation with distributed parameters in terms of input (Fig. 8).

The model of the composition operation $\Psi(B, C)$ is the result of the composition of C and B operations, and the model of the composition operation $\Psi(A, B)$ is the composition of B and A operations.

Since RE of C operation is lower than RE of B operation, and RE of B operation is lower than RE of A operation, then RE of operation of $\Psi(B, C)$ composition is lower than RE of operation of $\Psi(A, B)$ composition. This is because of the fact that $\Psi(A, B)$ and $\Psi(B, C)$ operations include B operation. Therefore, the ratio of ratings of C and A operations determine RE of the composition operations.

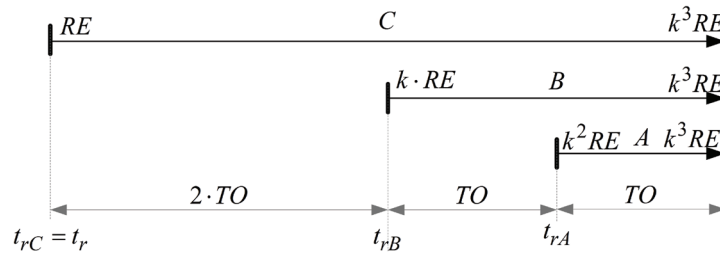

Fig. 7. Definition of simple models of global operations of different duration with predetermined rating efficiency

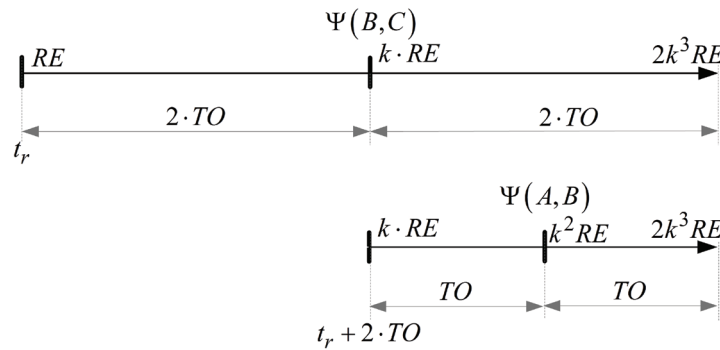

Fig. 8. Reference models of operations with distributed parameters in terms of input with different duration and predetermined rating efficiency

Such approach makes it possible to create reference classes of global models of operations with distributed parameters in terms of input and with predetermined rating efficiency.

4. 2. Development of a method for determination of global models of operations with distributed parameters in terms of input

1. The first stage of the method for construction of reference models of operations of different duration with distributed parameters in terms of input is determination of parameters of the set of initial data ($RE > 0, k > 1, t_r \geq 0, TO > 0$).

For example, we assume that $RE = 1; k = 1.1; t_r = 0; TO = 1$.

2. The second stage we determine parameters of three models of simple operations A, B and C of different duration with predetermined rating efficiency.

Then

$$t_{rC} = t_r = 0, RE_C = RE = 1, TO_C = 4 \cdot TO = 4, PE_C = k^3 \cdot RE = 1.331;$$

$$t_{rB} = t_r + 2 \cdot TO = 2, RE_B = k \cdot RE = 1.1, TO_B = 2 \cdot TO = 2, PE_B = k^2 \cdot RE = 1.331;$$

$$t_{rA} = t_r + 3 \cdot TO = 3, RE_A = k^2 \cdot RE = 1.21, TO_A = TO = 1, PE_A = k^3 \cdot RE = 1.331 \text{ (Fig. 9).}$$

3. At the third stage, we perform the composition of B, C and A, B operations (Fig. 9).

The efficiency of A operation is higher than the efficiency of B operation, and the efficiency of B operation is higher than the efficiency of C operation. Therefore, $\Psi(A, B)$ composition operation has the higher rating efficiency comparing to $\Psi(B, C)$ composition operation.

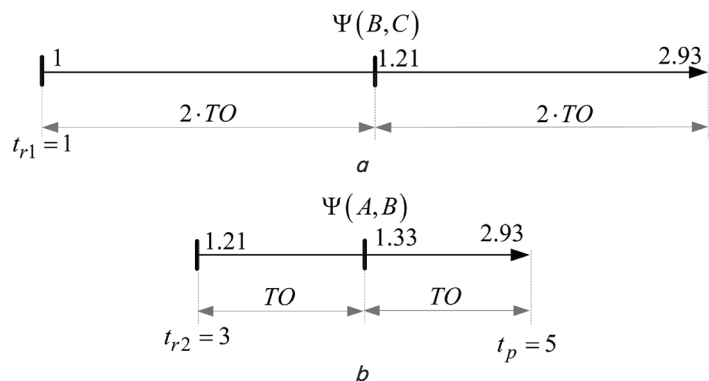

Fig. 9. Reference models of operations of different duration with parameters distributed in terms of input: a – basic operation; b – operation with predetermined higher efficiency

4. 3. Testing of an estimation indicator with the use of operations of the developed class

We use the models of the created reference operations (Fig. 9) to study capabilities of the indicator of the form $Q = f(re(t), pe(t))$ verified on two classes of synchronized operations with distributed parameters [28, 31]:

$$E = \frac{\int_{t_0}^{t_d} \left(\int_{t_a}^t \left(\int_{t_0}^t pe(t) dt - \int_{t_0}^t re(t) dt \right) dt \right) dt}{\int_{t_0}^{t_d} \left(\int_{t_0}^t re(t) dt - \int_{t_0}^t \left(\int_{t_0}^t pe(t) dt \right) dt \right) dt},$$

where t_a is the moment of logical completion of an operation, we can determine it on the basis of equality conditions for functions [26]:

$$\int_{t_0}^t re(t) dt \Big|_{t_0}^t = \int_{t_0}^t pe(t) dt \Big|_{t_0}^t; t_d = t_a + 1.$$

We use a specially developed software product [32] to quantify the value of E indicator E .

To do this, we introduce the values $t_{r1}=1$ and $t_{r2}=3$ in the «Time» section of the «Expenses/Costs» module, and the values $RE_1=1$ and $RE_2=1.21$ in the «Sum» section of the same module by sequentially pressing the «Insert Record» button.

We enter data related to the output product ($t_p=5$; $PE=2.93$) into the sections in the corresponding areas of the «Results» module (Fig. 10).

There is $\Psi(B, C)$ operation model displayed in a tabular form and the results of calculation of EE , Res and E indicators of the operation under study in the «Indicators» section.

Fig. 11 shows the program interface with input and output data for the operation.

It is clear from the results of the efficiency estimation (Fig. 10, 11) that the value of $E_{BC}=0.00923$ is less than the value of $E_{AB}=0.00952$. This means that E indicator passed the next stage of testing successfully.

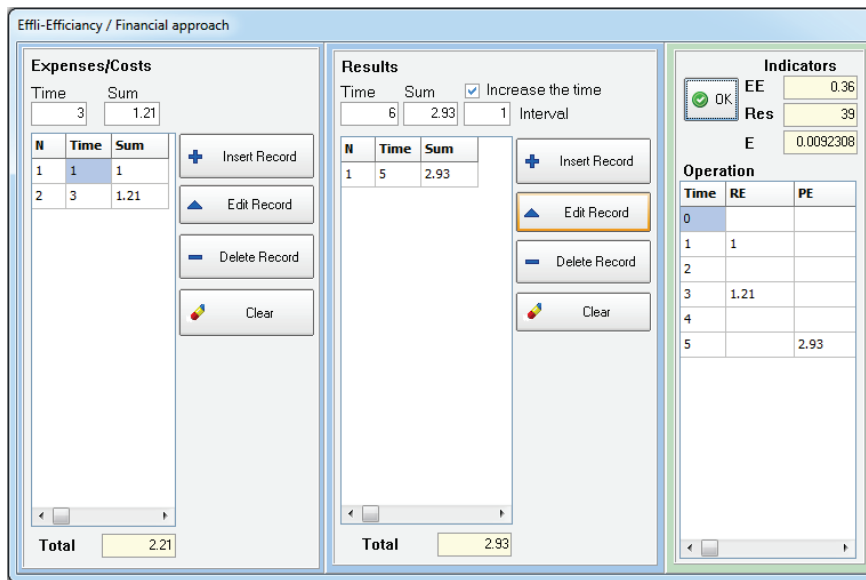

Fig. 10. Software interface with the results of input and output of $\Psi(B, C)$ operation data Ψ

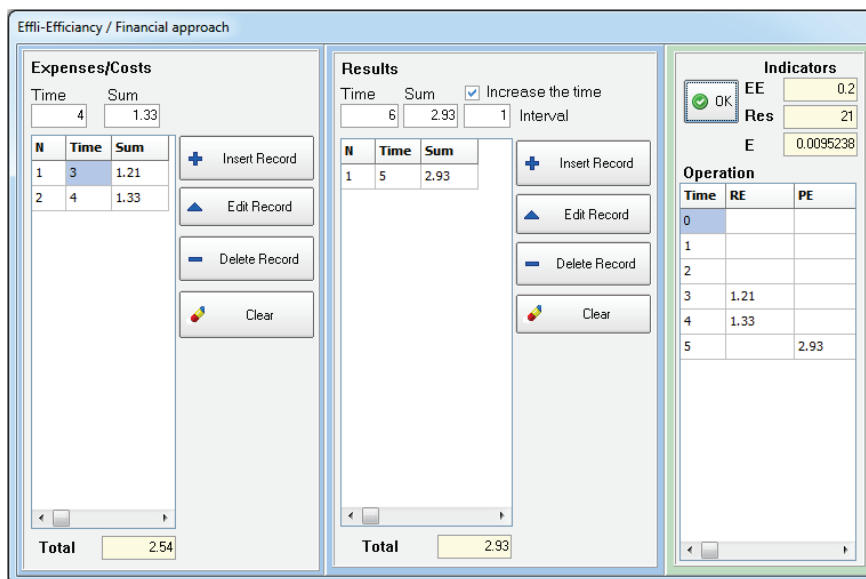

Fig. 11. Software interface with the results of input and output of operation data $\Psi(A, B)$

5. Discussion of research results related to development of the method of verification of the effectiveness formula

The essence of the scientific results obtained in the study consists in determination of the method for formation of a class of test reference operations with input parameters distributed in terms of input. The class serves to verify estimation indicators in relation with their ability to assess the effectiveness of operational processes adequately.

The base of the idea of the study is a use of the axiom, according to which the transfer of resources from an output of a previous operation to an input of a subsequent operation cannot pass without material losses, which in turn have a non-zero value.

The use of a composition of operations of different duration synchronized by an output gives possibility to create models of test operations with distributed parameters in terms of input and for different duration.

It is possible to obtain such a result because the short A operation with parameters $[[RE_A=(k \cdot RE + \Delta RE); TO_A=TO; PE_A=k^2 \cdot RE]$ is equivalent to the longer B operation with the parameters $[RE_B=RE; TO_B=2TO; PE_A=k^2 \cdot RE]$ by efficiency only if $\Delta RE > 0$.

Since the composition includes the short with the parameter $\Delta RE=0$, A operation is more efficient than B operation.

As a result, we obtain that the test operation based on shorter operations is more effective than the test operation based on longer operations.

The base of novelty of the proposed method is a new scientific position according to which, of two A and B operations with parameters $[RE_A=k \cdot RE; TO_A=TO; PE_A=k^2 \cdot RE]; [RE_B=RE; TO_B=2TO; PE_A=k^2 \cdot RE]$ synchronized by an output, A operation is more efficient.

The advantage of the study is the creation of a new class of test operations with distributed parameters in terms of input, which gives a possibility to improve reliability of verification of a class of estimation indicators oriented to operational processes with distributed parameters.

The disadvantage of the method is that a composition operation involves a use of models of simple operations with multiple time intervals and equivalent output parameters of operations.

Restrictions on creation of a class of test operation models relate to the use of a rigid algorithm used to formulate parameters of composition operations. Based on the proposed method, we can create operations only with discrete evenly distributed parameters in terms of input.

The development of the proposed method expanded verification capabilities for a class of estimation indicators with structure based on a use of two parameters ($re(t)$, $pe(t)$).

An extension of the class of models of test operations can go in the direction of creation of models of test operations with nonlinearly distributed parameters, as well as continuous (non-discrete) models of operations.

On the other hand, there is a need for studies that would justify expediency of further expansion of the classes of test operations.

6. Conclusions

1. We defined rules for the formation of a limited class of global models of operations of different duration with distributed parameters in terms of input and predetermined rating efficiency. The development of rules for the formation of a new class of reference operations makes it possible to formalize and automate the procedure for creation of them. In turn, automation of the verification method increases

productivity and efficiency of the procedure for synthesizing a structure of functional systems.

2. We developed the method for the formation of a new class of reference operation models. A feature of the new class is a distributed character of parameters of operations in terms of input and a predetermined value of their rating efficiency. The test result is positive if the rating of operations obtained using the verified expression coincides with the predefined rating of test operations. As a result, reliability of the verification method increases due to expansion of the number of classes of models of reference operations.

3. We tested the estimation with a structure based on the two of parameters ($re(t)$, $pe(t)$) using the new class of reference models of operations with distributed parameters in terms of input and different duration in time. At the same time, we obtained a higher value of the estimation indicator as a result of the estimation of the short operation, with respect to the results of the estimation of a longer operation. This indicates that the tested indicator estimated operations correctly in relation to the predetermined rating of efficiency.

References

1. Lee T. H., Adams G. E., Gaines W. M. Computer process control: Modeling and Optimization. John Wiley & Sons, 1968. 386 p.
2. Bennet S. A History of Control Engineering 1800–1930. The Institution of Engineering and Technology, 2008. 214 p.
3. Peters T. J., Waterman R. H. In search of excellence (lessons from America's best-run companies). Harper & Row, 1982. 400 p.
4. Bergmann A., Günther E., Kara S. Resource Efficiency and an Integral Framework for Performance Measurement // Sustainable Development. 2017. Vol. 25, Issue 2. P. 150–165. doi: <https://doi.org/10.1002/sd.1669>
5. Wu Y., Cheng T. C. E. Henig efficiency of a multi-criterion supply-demand network equilibrium model // Journal of Industrial and Management Optimization. 2006. Vol. 2, Issue 3. P. 269–286. doi: <https://doi.org/10.3934/jimo.2006.2.269>
6. Korotkevich L. M., Barsukov A. A. Added value as efficiency criterion for industrial production process // Science & Technique. 2016. Vol. 15, Issue 6. P. 536–545. doi: <https://doi.org/10.21122/2227-1031-2016-15-6-536-545>
7. Liberti L. Problems and exercises in Operations Research. Ecole Polytechnique, 2006. 128 p.
8. Barskiy L. A., Kozin V. Z. Sistemniy analiz v obogashchenii poleznykh iskopaemykh. Moscow: Nedra, 1978. 486 p.
9. Ivanov A. A. Genezis ponyatiya effektivnosti v svete obshchestvenno-ekonomicheskikh transformatsiy // Vestnik Omskogo Universiteta. Seriya: Ekonomika. 2015. Issue 4. P. 29–37.
10. Evdokimova T. V. Analiz genezisa teoreticheskikh podhodov k ponyatiyu i ocenke effektivnosti // Vestnik Tomskogo gosudarstvennogo universiteta. Ekonomika. 2013. Issue 3 (23). P. 22–27.
11. Struchkov I. A., Roschin P. V. Energy efficiency challenge of waxy oil production by electric submersible pumps // Resource-Efficient Technologies. 2017. Vol. 3, Issue 2. P. 194–197. doi: <https://doi.org/10.1016/j.refit.2017.04.003>
12. Optimization of the structure of multifunctional information systems according to the criterion of a required value of the efficiency ratio / Anishchenka U. V., Kryuchkov A. N., Kul'bak L. I., Martinovich T. S. // Automatic Control and Computer Sciences. 2008. Vol. 42, Issue 4. P. 203–209. doi: <https://doi.org/10.3103/s0146411608040068>
13. Miskowicz M. Efficiency of Event-Based Sampling According to Error Energy Criterion // Sensors. 2010. Vol. 10, Issue 3. P. 2242–2261. doi: <https://doi.org/10.3390/s100302242>
14. Cost function shaping of the output error criterion / Eckhard D., Bazanella A. S., Rojas C. R., Hjalmarsson H. // Automatica. 2017. Vol. 76. P. 53–60. doi: <https://doi.org/10.1016/j.automatica.2016.10.015>
15. Kantarelis T. D., Kantarelis D. In search of the criterion standard test in diagnostic testing // American Journal of Medical Research. 2017. Vol. 4, Issue 1. P. 118–140. doi: <https://doi.org/10.22381/ajmr4120179>
16. Strömberg E. A., Hooker A. C. The effect of using a robust optimality criterion in model based adaptive optimization // Journal of Pharmacokinetics and Pharmacodynamics. 2017. Vol. 44, Issue 4. P. 317–324. doi: <https://doi.org/10.1007/s10928-017-9521-5>
17. Lakner S., Brenes-Muñoz T., Brümmer B. Technical Efficiency in Chilean Agribusiness Industry: A Metafrontier Approach // Agribusiness. 2017. Vol. 33, Issue 3. P. 302–323. doi: <https://doi.org/10.1002/agr.21493>
18. Reuter M., Patel M. K., Eichhammer W. Applying ex-post index decomposition analysis to primary energy consumption for evaluating progress towards European energy efficiency targets // Energy Efficiency. 2017. Vol. 10, Issue 6. P. 1381–1400. doi: <https://doi.org/10.1007/s12053-017-9527-2>

19. Pollini N., Lavan O., Amir O. Minimum-cost optimization of nonlinear fluid viscous dampers and their supporting members for seismic retrofitting // *Earthquake Engineering Structural Dynamics*. 2017. Vol. 46, Issue 12. P. 1941–1961. doi: <https://doi.org/10.1002/eqe.2888>
20. Engau A. Proper Efficiency and Tradeoffs in Multiple Criteria and Stochastic Optimization // *Mathematics of Operations Research*. 2017. Vol. 42, Issue 1. P. 119–134. doi: <https://doi.org/10.1287/moor.2016.0796>
21. Shiau A. C., Shiau T.-H., Wang Y.-L. Efficient absorbants in generalized de Bruijn digraphs // *Discrete Optimization*. 2017. Vol. 25, Issue 25. P. 77–85. doi: <https://doi.org/10.1016/j.disopt.2017.01.005>
22. Omelchenko I. N., Brom A. E., Sidelnikov I. D. The criterion of supply chain efficiency and plotting the target function in tasks of logistics optimization for complex equipment // *Organizer of Production*. 2017. Vol. 25, Issue 4. P. 83–91. doi: <https://doi.org/10.25065/1810-4894-2017-25-4-83-91>
23. Kilian A. *Advanced Process Control for Maximum Resource Efficiency // Resource Efficiency of Processing Plants: Monitoring and Improvement*. Wiley, 2018. P. 239–263. doi: <https://doi.org/10.1002/9783527804153.ch10>
24. Development of system operations models hierarchy on the aggregating sign of system mechanisms / Lutsenko I., Fomovskaya E., Vihrova E., Serdiuk O. // *Eastern-European Journal of Enterprise Technologies*. 2016. Vol. 3, Issue 2 (81). P. 39–46. doi: <https://doi.org/10.15587/1729-4061.2016.71494>
25. Formal signs determination of efficiency assessment indicators for the operation with the distributed parameters / Lutsenko I., Fomovskaya E., Oksanych I., Vikhrova E., Serdiuk O. // *Eastern-European Journal of Enterprise Technologies*. 2017. Vol. 1, Issue 4 (85). P. 24–30. doi: <https://doi.org/10.15587/1729-4061.2017.91025>
26. Lutsenko I. Definition of efficiency indicator and study of its main function as an optimization criterion // *Eastern-European Journal of Enterprise Technologies*. 2016. Vol. 6, Issue 2 (84). P. 24–32. doi: <https://doi.org/10.15587/1729-4061.2016.85453>
27. Development of the method for testing of efficiency criterion of models of simple target operations / Lutsenko I., Vihrova E., Fomovskaya E., Serdiuk O. // *Eastern-European Journal of Enterprise Technologies*. 2016. Vol. 2, Issue 4 (80). P. 42–50. doi: <https://doi.org/10.15587/1729-4061.2016.66307>
28. Development of criterion verification method for optimization of operational processes with the distributed parameters / Lutsenko I., Fomovskaya E., Oksanych I., Serdiuk O. // *Radio Electronics, Computer Science, Control*. 2017. Issue 3. P. 161–174. doi: <https://doi.org/10.15588/1607-3274-2017-3-18>
29. Lutsenko I. Development of a verification method of estimated indicators for their use as an optimization criterion / Lutsenko I., Fomovskaya E., Oksanych I., Koval S., Serdiuk O. // *Eastern-European Journal of Enterprise Technologies*. 2017. Vol. 2, Issue 4 (86). P. 17–23. doi: <https://doi.org/10.15587/1729-4061.2017.95914>
30. Development of the method for modeling operational processes for tasks related to decision making / Lutsenko I., Oksanych I., Shevchenko I., Karabut N. // *Eastern-European Journal of Enterprise Technologies*. 2018. Vol. 2, Issue 4 (92). P. 26–32. doi: <https://doi.org/10.15587/1729-4061.2018.126446>
31. Development of test operations with different duration in order to improve verification quality of effectiveness formula / Lutsenko I., Fomovskaya O., Vihrova E., Serdiuk O., Fomovsky F. // *Eastern-European Journal of Enterprise Technologies*. 2018. Vol. 1, Issue 4 (91). P. 42–49. doi: <https://doi.org/10.15587/1729-4061.2018.121810>
32. Programma dlya rascheta effektivnosti operaciy. URL: <https://ru.files.fm/f/m4848k6k>