

Процес намотування є одним з основних процесів текстильної промисловості. Якістю формованих пакувань значною мірою визначається якість кінцевої продукції текстильної промисловості, а також продуктивність праці і устаткування. Тому увага до аналізу процесу формування пакувань, створення нових перспективних способів і конструкцій механізмів намотування не слабшає вже багато десятиліть. Розглядаються питання, пов'язані з аналізом методів контролю якістю структури пакувань хрестового намотування, які використовуються в прядильному виробництві. Під структурою намотування в даній роботі будемо розуміти взаємне розташування ниток при їх укладанні на поверхню пакування. Таким чином, параметрами структури будуть такі величини, як кут підйому витка, відстань між точками розвороту витків, крок витків і т. ін.

Відомо, що взаємне розташування витків на тілі намотування при фрикційній приводі пакувань не є однорідним. При певних співвідношеннях між частотою обертання бобіни і частотою руху нитководія відбувається укладання ниток на один і той же місце. При цьому спостерігаються, так звані, джгутові утворення. У разі, якщо частоти руху бобіни і нитководія незначно відрізняються від кратних, витки укладаються щільно один до одного, в цьому випадку формується стрічкова намотування. Джгутова намотування супроводжується рядом явищ, які негативно позначаються на якості формованих пакувань. При цьому параметри зсуву і зміщення визначаються на підставі емпіричних даних. Для обґрунтованого підходу до вибору технологічних параметрів таких механізмів проведено теоретичний аналіз процесу формування джгутових структур з точки зору силових взаємодій ниток. Для проведення такого вибору необхідно мати інструментальну методичку кількісної оцінки параметрів структури намотування, тому детально розглянуті методи їх реєстрації

Ключові слова: дефекти намотування, дефекти структури, стрічкова намотування, джгутова намотування, зрушення витків, точка розвороту витка

DEVELOPMENT OF METHODS TO CONTROL QUALITY OF THE STRUCTURE OF CROSS-WOUND PACKAGES

M. Nuriyev

Doctor of Technical Sciences, Professor*

E-mail: mehman62@mail.ru

I. Seydaliyev

PhD, Associate Professor*

E-mail: ilham.seydaliyev@mail.ru

*Department of Standardization and Certification

Azerbaijan State Economic University (UNEC)

Istiglaliyyat str., 6, Baku, Azerbaijan, AZ 1001

1. Introduction

The relevance of the further development of issues related to forming the cross-wound packages for spinning machines is predetermined by the increased requirements to the quality of packages. This is especially true for packages formed at machines that implement the new spinning techniques – rotor and pneumatic-mechanical, as well as the spinning-torsional and torsional ringless machines.

Papers [1, 2] give convenient criteria to categorize the structure of winding. Thus, the filament winding is the winding at which the distance between the turns of a thread is smaller than its diameter d_t , that is:

$$\Delta \leq d_t. \quad (1)$$

The tape winding is the winding at which the distance between the turns of a thread is less than three diameters of the thread:

$$\Delta \leq 3d_t. \quad (2)$$

For commonality of reasoning, we assume that the defective winding structures are formed when:

$$\Delta = kd_t, \quad (3)$$

The structure of winding is understood in this paper as the mutual arrangement of threads. In this case, the winding's structure parameters are the following quantities:

- thread's turn lifting angle β ;
- central angle φ between the points of reversal of turns;
- a distance between thread turns Δ in the direction perpendicular to the turn;
- a distance between the turns of thread Δ_0 in radial direction.

where k is the number from 0 to 3, denoting the strictness of requirements to the winding structure. At $0 < k < 1$, the winding is the filament one, and at $1 < k < 3$, this is the tape winding.

Next, we consider the process of defect formation in the winding structure. Fig. 1 shows the developed view of a bobbin surface. A turn is laid on the bobbin surface in the form of a periodic curve whose wavelength is denoted via L .

The origin for measuring the length of the circumference of the package is taken to be a point of the turn reversal at one of the ends. If one finds that any of the turn reversal points A_1, A_2, \dots, A_n exactly matches one of the points B_1, B_2, \dots, B_m , which are at a distance multiple to the length of the bobbin's circumference, it would mean that the turn is laid at the same place, thereby forming the filament winding. This will occur in any case if:

$$mL = \pi Dn, \tag{4}$$

where m and n are the integers.

If condition (4) is not satisfied, then the distance Δ_θ between turns, as it follows from Fig. 1, can be calculated from formula:

$$mL - \pi Dn = \Delta_\theta. \tag{5}$$

The number m that is equal to the number of double runs over which the turn is laid on the original place, shall be termed a layout cycle. Because in determining a defect of the structure there appears the magnitude Δ_θ we can record:

$$(mL - \pi Dn)\sin\beta = \Delta_\theta, \quad |(mL - \pi Dn)\sin\beta| \leq kd_t. \tag{7}$$

Expression (4) can be re-recorded in the form:

$$\frac{L}{\pi D} = \frac{m}{n}. \tag{8}$$

Then, by dividing the numerator and denominator from the left side of the equation by the bobbin surface circumferential speed, we obtain:

$$\frac{T_s}{T_b} = \frac{n}{m}, \tag{9}$$

where T_b and T_s are the periods of motion of the bobbin and the spreader.

Given that $T=1/f$, where f is the frequency, (9) can be rewritten in the form:

$$\frac{f_b}{f_s} = \frac{n}{m}. \tag{10}$$

Expression (10) makes it possible to consider the process of filament formation as a process of interference, that is, adding two wave processes, one with the wavelength L , and the other with a wavelength of πD . Given these patterns, one can see that the numbers m and n have a definite physical meaning. If one cuts a plane through the bobbin, perpendicular to its axis, the number of pairs of intersections between this plane and the line of the turn is m . The developed view of the bobbin surface shows this plane as a straight line $a-a$. The number n equals the number of points of intersection with the forming bobbin over a full laying cycle.

Cylindrical cross-wound packages, produced at spinning machines the type of PPM-120, PR-150, PK-100 and PSK-225 SHG, are used in weaving or knitting industries. Depending on the purpose of yarn, packages are delivered as a weft or a base to textile production after preliminary rewinding or directly from the above-specified machines. Twisted yarn from the unit PSK-225 SHG undergoes additional twisting at the torsional machines of double twisting. The need for a preliminary rewinding of the package before using is defined by the yarn mass on the package. Thus, warping from the bobbin PK-100 was not practically applied, despite the efforts in trying.

The quality of package winding significantly affects thread breakage during the specified operations in textile production.

Consider specific examples. The textile park in Sumgait (Azerbaijan) employs as the base in the manufacture of muslin the 20 Tex yarn, produced at machines PPM-120. Results of monitoring the breakage of this yarn at warping machines are given in Table 1. It follows from analyzing it that the causes of breakage related to defects in winding accounted for 22 % of the total number of breakages.

To determine the reasons for breakages that are categorized in technological practice as breakages due to a violation of the shape of a bobbin and the flyoffs of turns, we additionally monitored the breakage at warping machines. In this case, we controlled a diameter of the winding that experienced a breakage. Control was executed after 8 rollers worked 330 threads each. The averaged results for two rollers, which corresponds to working out a full bobbin, are shown in Fig. 2. The shading indicates the breakages due to defects in winding. The results of breakage measurements (Fig. 2) were compared with the diagram of the winding structure for machine PPM-120 [3, 4], which quantitatively shows the distribution of the winding structure defects along the radius of winding. Comparison has shown that the region of greatest breakage, located between the winding diameters of 140–200 mm, coincides with the largest number of defects in the winding in the form of harnesses and tape.

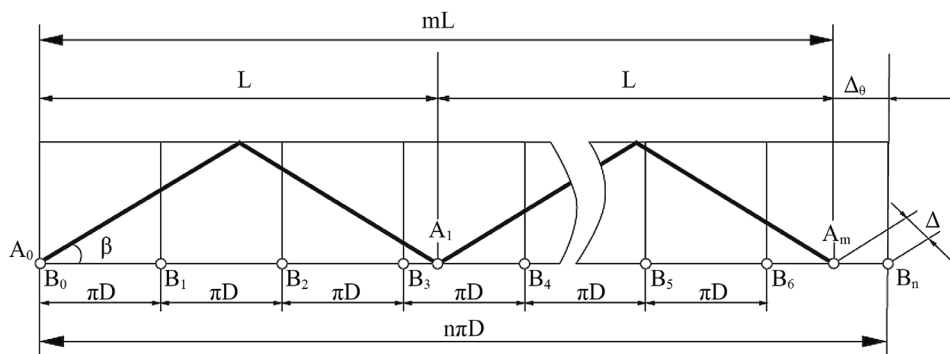

Fig. 1. Schematic of winding formation

Table 1

Results of monitoring the breakage at warping machines. Muslin, base 20 Tex., 330 threads

No.	Breakage per roller	Breakage due to irregular shape of bobbin		Turn flyoff		Total due to defects in winding	
		qty.	%%	qty.	%%	qty.	%%
1	37	6	16		–	6	16
2	35	8	23	–	–	8	23
3	30	6	20	4	13	10	33
4	29	5	17	6	20	11	37
5	25	4	14	–	–	4	16
6	28	2	7	–	–	2	7
7	29	5	17	–	–	5	17
8	31	6	19	2	6	8	25
9	30	7	23	4	13	11	36
10	37	6	16	6	16	12	32
11	40	8	20	6	15	14	35
12	36	6	16	4	11	10	27
13	40	6	15	–	–	6	15
14	43	3	7	2	5	5	12
15	36	2	5	–	–	2	5
16	30	6	20	–	–	6	20
Mean	33.5	5.4	16	2	6	7.4	22

Fig. 2 also shows the peaks in breakage at diameters of 80–110 mm and 210–230 mm, which, as demonstrated by diagram [3], corresponds to the harness diameters as well.

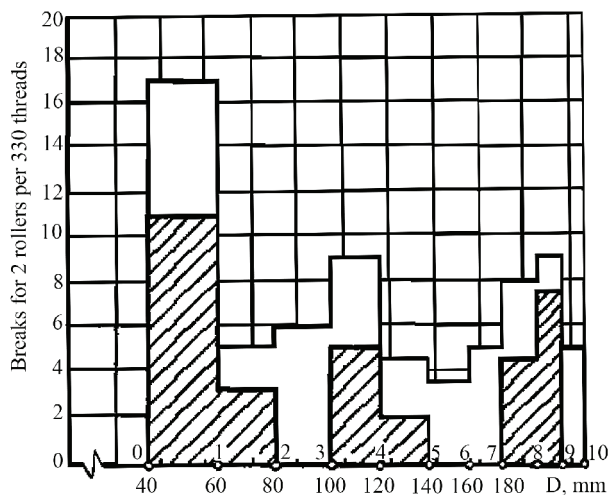

Fig. 2. Dependence of breakage when winding cylindrical bobbins wound at machine PPM-120 on the diameter of winding

This allows us to conclude that the violations of the winding shape and the flyoffs of turns accompany the braid formation and could possibly be its consequence.

To verify this provision, we monitored the breakage at winding machines during winding the bobbins obtained at the spinning-torsional machine PK-100M3. Based on these data, the breakage of thread due to defects in the winding is 58 % on average. In this case, the main defect of winding at machine PK-100M3 is the flyoffs of turns that typically accompany braid winding.

Fig. 3, 4 show photographs of ends of packages from machines PK-100M3 and PSK-225 SHG. They clearly demonstrate defects in the form of turn flyoffs and show that they form at the end surface of the package a roll of threads laid in a braid (shown by arrows).

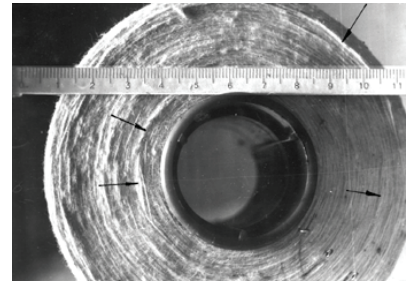

Fig. 3. End side of the package wound at machine PK-100M3

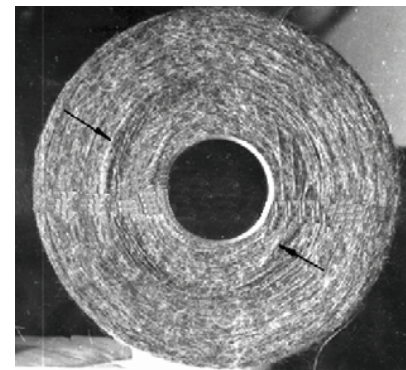

Fig. 4. End side of the package wound at machine PSK-225 SHG

The effectiveness of measures aimed at the elimination of defects in winding depends on labor-intensity of the elimination of breakages during the operations where packages, formed in spinning production, are applied. The smallest effect will be produced, in this case, when packages are re-wound, and the greatest – in the process of post-twisting the yarn at the double twisting machines, at warping and at spinning units where yarn is used as weft.

Consider the estimation methods for assessing the parameters of a winding structure. The winding structure parameters depend on design of the winding mechanism and affect many technological properties of the package and its capability to processing.

In the case of stationary motion of the system «winding shaft – bobbin» the kinematic ratios between the number of runs of the thread guide and the number of rotations of the bobbin, at which distance $\Delta=0$ are stated in papers [5, 6]. Study [7] reports results of the simulation of the yarn unwinding process from the package and the influence of defects on its quality.

Paper [8], in order to assess the structure of the winding, applies distance Δ_0 in the circumferential direction between successive turns. It is determined by calculation under

conditions of the nonstationary motion of the system «winding shaft – bobbin» only when the gear ratio between the bobbin and the winding shaft is $i \approx 1$. This method certainly cannot be employed to estimate the structure of the winding of the entire package.

In many cases, these parameters are determined by the kinematical ratios in the winding mechanism, which is why their analysis employs calculation methods. The reported procedure is designed to calculate the angular and linear distance between the turns of a thread based on the kinematical scheme of the winding mechanism depending on the diameter of the package winding. A linear distance between adjacent turns defines such a defect as the braid winding when neighboring turns are stacked on top of each other.

A drawback of the described procedure that should be noted is the lack of orientation towards the use of computational equipment, which makes it impossible to check the formation of a braid winding for all diameters.

Papers [9, 10] describe the procedures for analyzing the winding structure using a computer. Study [10] suggested two criteria to analyze the presence of a braid winding: the degree of a turn fixation and the uneven distribution of the turn reversal points along the circumference of the bobbin. The first criterion is defined as the distance e along the generatrix of the bobbin between point K of the intersection of two adjacent turns and the extreme position of the thread guide U (Fig. 5), which can be found from equation:

$$\frac{dW}{W} = \frac{e}{H}, \tag{11}$$

where H is the thread guide path; $W = \omega/f$ is the ratio of the angular rotation frequency of the bobbin to frequency of the thread guide motion (a winding ratio), dW is the relative change in the winding ratio.

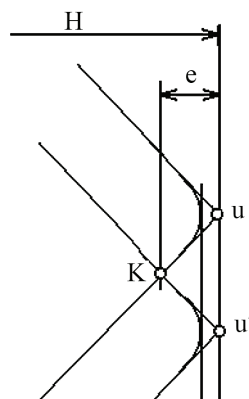

Fig. 5. Diagram of arrangement of thread turns at a bobbin surface

If this distance is less than the assigned magnitude, the turn is considered poorly fixed thereby making it possible to break the law of laying the turns set by the thread guide. Article [10] gives an example of the permissible distance $e = 2$ mm.

The second criterion is the uneven distribution of the reversal points along the outer surface of the bobbin, which is determined as follows. A bobbin is divided into 5 sectors. One then calculates how many reversal points are in each sector at a particular diameter of the bobbin. A numerical

characteristic of the non-uniform distribution of reversal points is the magnitude:

$$S = \frac{n_{\max} - n_{\min}}{n_{cp}}, \tag{12}$$

where n_{\max} and n_{\min} are the maximum and minimum number of turn reversals in the sector; n_{cp} is the mean number of reversals in the sector.

Paper [10] gives dependence graphs of these magnitudes on order of the braid, that is, on the diameter of the winding, for different thread guide’s motion disturbance laws that apply to disperse winding defects. Using the described procedure, the authors analyzed efficiency of different techniques for dispersing defects in the structure. An analysis of one of the dispersion techniques is given in [11].

To assess the negative effect of the braid winding, it is necessary to obtain a method to analyze the structure of winding in order to determine any possible diameters for braid formation, to define the intensity of this formation, or the thickness they would acquire. In addition, it is desirable that such a method should make it possible to compare the structures of winding, obtained using different winding mechanisms or the same winding mechanism under different modes of its operation.

3. The aim and objectives of the study

The aim of this study is to develop quality control methods to estimate the structure of cross-wound packages, which would ensure qualitative winding at spinning machines.

To accomplish the aim, the following tasks have been set:

- to clarify the reasons for the formation of defects in the winding structure in the form of the braid and tape winding;
- to investigate experimentally impact of the winding structure defects on suitability of packages for processing during subsequent operations;
- to state the generalized criterion for the estimation determination of the winding type;
- to explore two variants of structure formation – with and without dispersion of braid structures.

4. Procedure for the elaboration of quality control methods to estimate the structure of cross-wound packages

4. 1. Reasons for the formation of defects in the structure of winding in the form of the braid winding and tape winding

To solve the set problem, we shall solve inequality (7) relative to the parameter D :

$$\frac{m}{\pi n} L - \frac{kd_t}{\pi n \sin \beta} \leq D \leq \frac{m}{\pi n} L + \frac{kd_t}{\pi n \sin \beta}. \tag{13}$$

If one requires, when solving (13), an exact match between positions of the successive and preceding turns, that is, $k = 0$, we obtain values for braid diameters:

$$D = \frac{m}{\pi n} L. \tag{14}$$

Subtracting from the right side of expression (13) its left side, we obtain a range of diameters over which the inequalities are satisfied:

$$\Delta D = \frac{2kd_t}{\pi n \sin \beta} \tag{15}$$

According to (8), structure defects arise when the ratio of the layout wavelength L to length of the bobbin's circumference πD is an irreducible fraction.

At a constant turn lifting angle β this ratio depends only on diameter of the winding D . In the $L-\pi D$ coordinate system, each ratio $L/\pi D$ will be matched by a beam passing through the coordinate origin (Fig. 6).

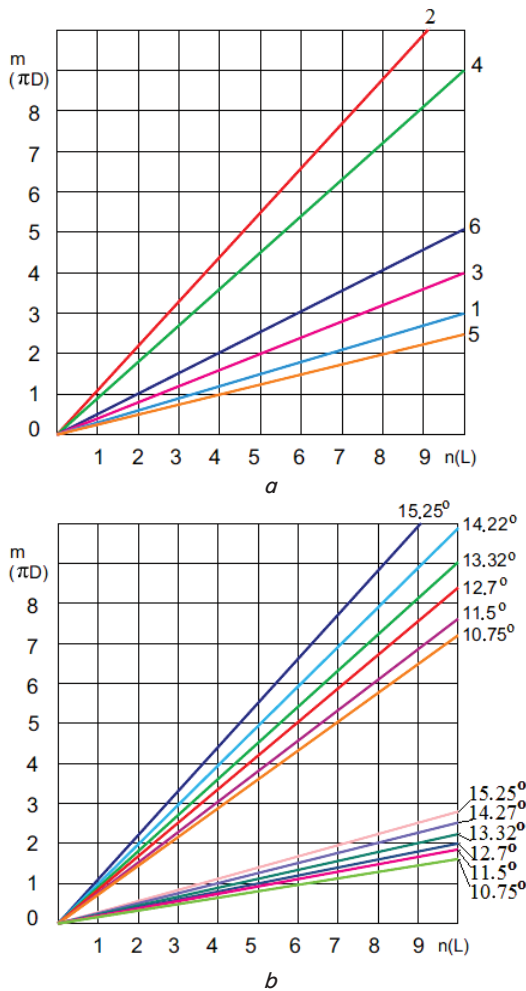

Fig. 6. The $L-\pi D$ diagram:

a , 1 and 2 – beginning and end of winding for machines PSK-225 SHG and PR-150, 3 and 2 – beginning and end of winding for machine for MM-150-2, 4 and 5 – beginning and end of winding for machine MM-150-L2; b – for machine PK-100 at different angles of lifting the turn

The number of structure defects can be determined based on the number of irreducible combinations m/n , confined inside the angle between beams $L/\pi D_{\min}$ and $L/\pi D_{\max}$. In Fig. 6, a , line 1 illustrates the winding formation using a cut-through drum with a diameter of 90 mm (2 turns) at a winding diameter of 56 mm. Line 2 gives the same, but at a winding diameter of 200 mm, which corresponds to winding

at machines PSK-225SHG and PR-200SH. All the irreducible combinations m/n , confined between straight lines 1 and 2, correspond to the winding structure defects.

By analyzing the diagram one can also estimate the strength of the defect. To this end, consider expression (13), from which it follows that the intensity decreases in proportion to the number n . Hence, Fig. 6 shows that the strongest braid $m/n=1$ under specified conditions forms at the diameter, close to the maximum diameter of the package. Thickness of the formations that occur when $n=2$ and $n=3$, that is, $m/n=1/2$, $m/n=1/3$ and $m/n=2/3$ is accordingly 3 times less. Defects that are generated at large values for n are of a smaller thickness. The observations found that the defects generated when $n > 6$ do not affect the quality of the winding, and at $n > 10$ they cannot be detected visually.

Because the $L-\pi D$ diagram can be built in the dimensionless magnitudes $m-n$, it can be used to compare the structure of the winding of packages generated at different machines or at the same machine at different settings of the bobbin winder. Fig. 6 shows (line 3) the winding on a cut-through drum with a diameter of 90 mm (2.5 turns) around a 90-mm diameter cartridge, which corresponds to the winding at machine MM-150-2. The resulting winding diameter at this machine is 200 mm. It is shown by line 4. Fig. 6 demonstrates that an increase in the diameter of the cartridge made it possible to eliminate the defect generated when $m/n=1/3$, as well as seven more, less significant, defects. At the same time reducing the thickness of the winding layer decreases the number of defects, for example, at machine MM-150-L2 (lines 5 and 6 in Fig. 6, a).

Fig. 6, b shows diagrams for machine PK-100M3 with different values of the lifting angle of the turn. The diagram demonstrates that the choice of the turn lifting angle β can somewhat improve the structure of the winding. Thus, when winding at an angle of $\beta=14.22^\circ$, the worst defect at $m/n=1/1$ is missing, although there are defects at $m/n=1/4$ and $m/n=1/5$. Thus, the structure of winding when $\beta=14.22^\circ$ is more favorable for subsequent processing than that at $\beta=15.25^\circ$.

4. 2. Impact of the winding structure defects on the suitability of packages for processing at subsequent operations

Paper [4] shows the relationship between the turns flying off to the end of the package and the winding structure defects. Study [12] pointed to the experimentally established fact of the emergence of flyoffs at the ends, which could be partially eliminated by selecting the angle of turns crossing. This is consistent with the result obtained, however study [12] fails to provide a theoretical explanation of this phenomenon.

We estimate a range of diameters ΔD , ever which a defective winding forms, for example, at machine PK-100M3. In this case, we assume $n=1$ and $k=3$. The required estimated diameter of the thread can be obtained by employing known formula:

$$d_t = 0.00357 \sqrt{T/\delta}, \tag{16}$$

where T is the linear density of the thread, tex.; Δ is the volumetric weight of textile material (for cotton yarn).

Calculation results are summarized in Table 2. Table 2 shows that increasing the thickness of the wound thread and decreasing the lifting angle of a turn leads to an increase in the thickness of braid formations. This could possibly explain

a decrease in the number of thread flyoffs that contribute to the braid formation at an increase in the lifting angle of a turn, which was practically established during operation of machine PK-100-M3.

Table 2
Thickness of braid winding in mm for machine PK-100-M3

$T, (d, \text{mm}) \backslash 2\beta^\circ$	$21^\circ 15'$	23°	$24^\circ 21'$	$26^\circ 38'$	$28^\circ 27'$	$30^\circ 31'$
$7.4 \times 2 (0.15)$	1.55	1.43	1.36	1.24	1.16	1.09
$10 \times 2 (0.17)$	1.76	1.63	1.54	1.41	1.32	1.23
$11.5 \times 2 (0.19)$	1.97	1.82	1.72	1.58	1.47	1.38
$18.5 \times 2 (0.24)$	2.49	2.30	2.17	1.99	1.86	1.74
$25 \times 2 (0.27)$	2.80	2.59	2.44	2.24	2.09	1.96
$29 \times 2 (0.29)$	3.01	2.78	2.62	2.41	2.25	2.10

The tendency observed is opposite to that observed earlier in terms of the number of defects in the structure, that is, increasing the lifting angle of a turn leads to an increase in the number of defects, although their thickness decreases in this case. And, as Table 2 shown, this reduction within the range of regulation, permitted by the design of a machine, is quite substantial.

Values for the thickness of a braid winding, given in Table 2, correspond to $n=1$, that is, to the strongest formation. For other values of n , the thickness decreases proportionally and, at $n=10$, is roughly equal to a thickness of the thread, that is, it will not exert any significant impact on the process of winding.

All the above relates to the friction winding in the absence of dispersing mechanisms. Mechanisms of dispersion introduce disturbances to the motion of a thread guide or a bobbin, which disrupt the described process of forming the braid structures and improve the quality of winding in general. However, it is not possible to analyze the structure of winding in the presence of a dispersion mechanism of braid winding by applying the described method. That requires a method that takes into consideration the arrangement of reversal points of turns at the end of the package, as well as the actual change in winding thickness over time.

4. 3. Generalized criterion for the estimated determination of the type of winding

As shown above, in order to describe the structure of winding in general, in the presence of dispersion mechanisms, it is convenient to adopt, as a criterion, the distance between turns. In this case, to assess the thickness of the winding defect, one must have an actual dependence characterizing a growth in the diameter of winding due to the number of double runs by a thread guide. Applying time as an argument [13, 14] is not advisable in this case. It is much more convenient to use for this purpose the number of double runs by a thread guide [15–16].

4. 4. Analysis of the structure of winding in the presence of dispersing devices

Let a bobbin be rotated at some elementary angle $d\phi$, then the thread of the following weight will be wound around it:

$$dm = \frac{TDd\phi}{2000 \cos\beta}, \tag{17}$$

where T is the linear density of the thread wound, tex.; D is the current diameter of a winding body, m; β is the lifting angle of a turn averaged over a cycle of operation of the dispersing mechanism.

In this case, we assume that the thread weight is in the cylindrical layer of thickness $dD/2$ at the surface of the package, then:

$$dm = \frac{\pi\gamma(D)HDdD}{2}, \tag{18}$$

where γ is the winding density, g/m^3 ; H is the width of a package, m.

Equating the right sides of (17) and (18), we obtain an equation to determine the new value for the diameter of the package. Since we are interested in the increment of the diameter over a single double run of a thread guide, then we integrate for $d\phi$ in the range from ϕ_i to:

$$\phi_{i+1} = \phi_i + \frac{8H}{(D_i + D_{i+1}) \text{tg}\beta} \text{ (Fig. 7),}$$

that is:

$$\int_{D_i}^{D_{i+1}} \pi\gamma(D)HD dD = \int_{\phi_i}^{\phi_{i+1}} \frac{TDd\phi}{1000 \cos\beta}. \tag{19}$$

The dependence $\gamma=\gamma(D)$ is determined by a large number of factors, both structural and technological. The physical processes by which these factors affect the winding density have not been fully revealed up to now. Therefore, we assume that the dependence $\gamma=\gamma(D)$ was obtained empirically and represents the polynomial:

$$\gamma = AD^2 + BD + C, \tag{20}$$

where A, B , and C are the empirical coefficients.

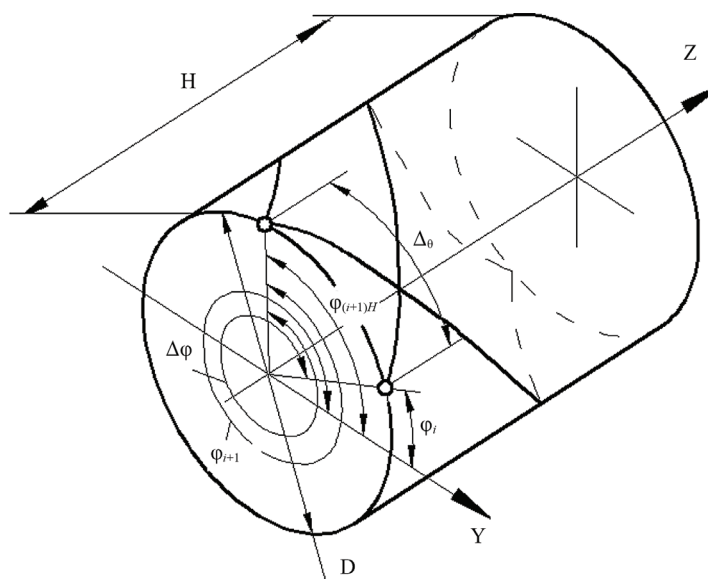

Fig. 7. Distance between turns at the surface of winding

This kind of dependences were defined by many authors [17–19] for practically all types of winding mechanisms currently used in the industry. Not a single analytical dependence between the density of winding and the package structure, which could specify the law of change in the density of winding due to an increase in its diameter, has been found so far.

Following the substitution (20) in (19) and integration, we obtain equation:

$$\frac{D_{i+1}^3}{3} + \frac{BD_{i+1}^2}{2} + CD_{i+1} - \frac{AD_i^3}{3} - \frac{BD_i^2}{2} - CD_i - \frac{8T}{1000\pi(D_i + D_{i+1})\sin\beta} = 0. \quad (21)$$

When estimating the structure of the generated layer, we assumed that the lifting angle of a turn over a single double run by the thread guide remains constant, and its change is due to a jump to the beginning of the new double run. This assumption makes it possible to dramatically reduce the cost of computer time to analyze the structure and does not entail significant errors. That is explained by that the duration of the thread guide's double run is very short in comparison not only to the time for forming a package, but also to the operation cycle of the dispersing mechanism.

It is more convenient to adopt as the points that define the position of a turn the reversal points of the turn at one of the package ends. The criterion for estimating the structure of winding in this case is the distance between the points of turn reversal, measured along the arc of circumference of the bobbin Δ_θ . Inequality (7) in this case takes the form:

$$|\Delta_\theta| \leq \frac{kd_i}{\sin\beta}. \quad (22)$$

To calculate, we take a cylindrical coordinate system (r, y, φ) associated with bobbin (Fig. 7). Arc length L at the outer surface of the package with diameter D , upon which a thread is laid over a single double run by a thread guide, is determined from:

$$L = \frac{2H}{\text{tg}\beta}, \quad (23)$$

where β is the current value of the layout angle, defined by the kinematic parameters of the braid winding dispersion mechanism.

This arc is matched by a central angle:

$$\Delta\varphi_i = 2L/D. \quad (24)$$

Thus, following a single double run by the thread guide, the reversal point of the turn will accept coordinate $\varphi_{i+1} = \varphi_i + \Delta\varphi$.

Subtract the part, multiple to 2π , from it:

$$\varphi_{(i+1)H} = \varphi_{i+1} - 2\pi \text{int}\left(\frac{\varphi_{i+1}}{2\pi}\right), \quad (25)$$

where $\varphi_{(i+1)H}$ is the normalized angular coordinate of the reversal point.

Linear distance between two adjacent reversal points of the turn along the arc on the outer surface of the bobbin is:

$$\Delta_\theta = \frac{\varphi_{(i+1)H} - \varphi_{iH}}{D_i}. \quad (26)$$

Because the formation of a defective winding may result in that not only each subsequent turn overlays the preceding one, but the following turns overlay each other in one, two or more turns, Δ_θ should be determined repeatedly at each double run of the thread guide from expression:

$$\Delta_{\theta m} = \frac{\varphi_{(i+1)H} - \varphi_{(i+1-m)H}}{D_i}, \quad (27)$$

where $\Delta_{\theta m}$ is the distance along the outer surface of the package between the newly laid turn and the turn, laid earlier by m double runs. The number m has the same physical meaning as the number m in expression (8), and it represents a multiplicity of braid winding.

When analyzing the structure of winding using the method described, we adopt $1 \leq m \leq 6$, because structures of higher multiplicity are of an insignificant thickness, and thus do not affect the technological parameters of packages.

Expressions (21), (27) are, in essence, the algorithm for calculating the distance between the reversal points of turns, while expression (22) is a criterion for estimating the structure of winding. They underlie the method for an analysis of the winding structure in a kinematic aspect.

The method implies the calculation of distances $\Delta_{\theta m}$ for each double run by the thread guide when forming a winding. In this case, we preliminary determine the turn lifting angle β , the layout width H , and other quantities that can vary by the dispersing mechanism in the process of forming a package. Given a certain number of double runs by the thread guide, we calculate the number of instances for meeting condition (22) and we plot it as a coordinate in the diagram describing the structure of the winding (Fig. 8). Abscissa is the diameter of winding, determined from equation (21).

Condition (22) is checked not only for the two consecutively laid turns, but also for the following ones, laid in 1, 2...6 turns.

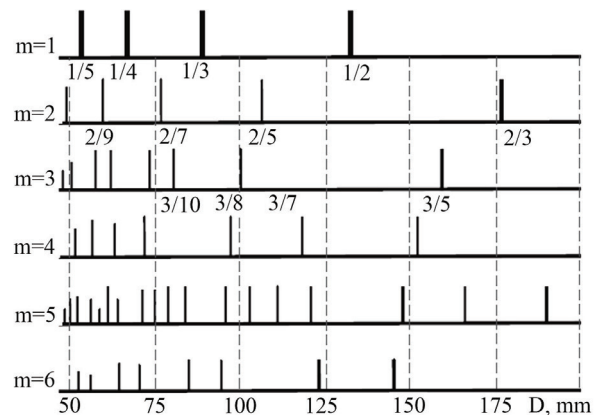

Fig. 8. Diagram of the winding structure, generated at machine PK-100M3 at $\beta = 10.75^\circ$

Comparative analysis of the calculation results shows that they agree well. Despite its complexity, the method is more informative. Indeed, the height of bars in the diagrams

shows the number of threads, stacked sequentially, one next to another, while the width of these bars corresponds to the range of diameters over which such a defect forms.

The proposed method enables to quantify the effectiveness of operation of the mechanisms of dispersion. Such an evaluation can be based on the height of bars in the winding structure diagram. However, operation of the dispersing mechanism may have a different impact on the braid structures generated on different diameters of winding. Therefore, in order to clarify the technological modes in the formation of a package, it is necessary to apply the methods of multicriteria optimization.

As shown in [20, 21], a winding structure analysis is easier to run by analyzing the movement of the working bodies of the winding mechanism directly during package formation. In the experimental setup, described in that work, the lever of the bobbin holder, close to the chuck, and near the winding shaft and a spreader, hosted the Hall sensors, bursting the pulses when a magnetic tag passed them. The number of pulses from sensors was calculated by digital electronic counters, which could determine the ratios of a thread guide motion frequency k to rotation frequency f/f_w of the winding shaft and to rotation frequency f/f_{sp} of the bobbin.

In addition, the counters made it possible to measure consecutive time intervals between pulses from the sensors located next to the bobbin and thread guide t_i, t_{i+1}, t_{i+2} , as well the motion periods of the thread guide and a bobbin.

Pulses from the sensors at the bobbin and thread guide were transmitted to a recording oscilloscope, making it possible to visually monitor in the screen the distance between the adjacent turns of the winding.

Data from the counters were used for a winding structure analysis and to estimate efficiency of dispersing a braid winding from inequality:

$$\left| \frac{t_i}{T_{spi}} - \frac{t_j}{T_{spj}} \right| \leq \frac{nx d_f}{mL |\sin \alpha|}, \quad (28)$$

where T_{sp} is the bobbin rotation period; x is the magnitude in the range of 0–3 mm characterizing a distance between threads; d_f is the thread diameter; L is the thread length, released over a single double run of the thread guide; α is the turn lifting angle; n, m are the integers 1–5, characterizing the multiplicity of braid winding.

Processing the results of measurements involved specialized software at the computer Wang-2000, which received data directly from the counters. The results of processing the data acquired were sent to the printer in the form of a bar diagram. The diagram shows dependence of the number of moves of the thread guide at which the distance between the threads is less than that specified on the relative radius ρ over a certain time interval. In this case, value for ρ is calculated from:

$$\rho = r / r_{1/1}, \quad (29)$$

where r is the current radius; $r_{1/1}$ is the radius at which the braid winding forms with a multiplicity of 1.

The latter method of control has a number of advantages. Given that the initial data are acquired from the working bodies rather than a thread, as is the case for the instruments described in [22–24], there are no errors that might be caused by the deformation of a thread and the difference in the motion laws for the thread and thread guide.

In contrast to the analytical methods described in the present work, a given method takes into consideration all the factors influencing the structure of winding. These include those neglected in calculations: irregularity of slippage, thread tension, bobbin clamp force to the winding shaft, etc.

However, the technique to control the winding structure parameters by controlling the movement of working bodies in winding mechanism has its limits, since it does not make it possible to estimate quality of the packages delivered for production from other factories. In this regard, the scope of its application is rather limited.

5. Discussion of results of studying the methods of control over a winding structure

To set the winding mechanisms, both under industrial conditions and when testing new equipment, the most acceptable are instrumental methods, based on an analysis of the package itself. The first step towards constructing such methods is to determine the actual curve of the turn arrangement on a winding body.

The specified drawbacks have been eliminated in the instrument ABA-R3060 made by Rothschild [25]. It is proposed to upgrade the instrument AVA-R3060 to process measurements results on a computer, which undoubtedly improves the efficiency of the measuring process. It should be noted that the described device is not without a substantial shortcoming, inherent in similar designs. Because of the considerable distance between the point where a thread leaves and the eye of a thread guide and its changes during operation, the instrument is not capable to reproduce the actual curve of laying a turn at the reversal. In this case, the curve itself is often disrupted due to that, that when forming a braid, the braid itself takes the role of a spreader, leading the thread away from the position defined by the thread guide motion.

We describe the procedure to register position of the thread at the reversal site, which implies rolling the package over an adhesive tape; in this case, a thread is glued, from a bobbin to the tape, in line with the position at which it was laid in the winding. A distance from the point where a thread leaves the package to the tape, which fixes it, is zero. It should be noted that such a procedure is suitable only to analyze the violations of the turn arrangement at the reversal site and cannot be applied to analyze the dispersing mechanism due to considerable time cost and tape consumption. To quantify defects in the winding structures, we introduce the notion of «the intensity of braid winding», that is, the number of threads per unit width of the defective structure.

This characteristic was determined in the following way. If one finds a defect in the process of unwinding, the unwinding is terminated; two needles are applied to the body of the winding so that a structural defect is located between them, while the straight line, passing through the points at which the needles have been inserted, is perpendicular to the threads at the surface of the package. The application of the needles is followed by unwinding manually, in this case, we calculate the number of threads k located between the needles.

The ratio of the number of threads in a defect to distance l between the needles can be termed the intensity of braid winding q , that is:

$$q = k / l. \quad (30)$$

This magnitude makes it possible to categorize a flaw in the winding as a tape or a braid. Indeed, braid winding is, by definition, the one at which the distance between threads is less than the thickness of the thread, while tape winding is the one at which this distance is the thickness of the thread. Intensity indicates how many threads are hosted per unit width of a winding defect and is the inverse magnitude relative to the distance between threads.

Fig. 9 shows dependence chart of intensity of braid winding q on a winding diameter for machine PSK-225 SHG. The dashed lines demonstrate diameters for the respective ratios m/n , according to the model for forming the braid winding.

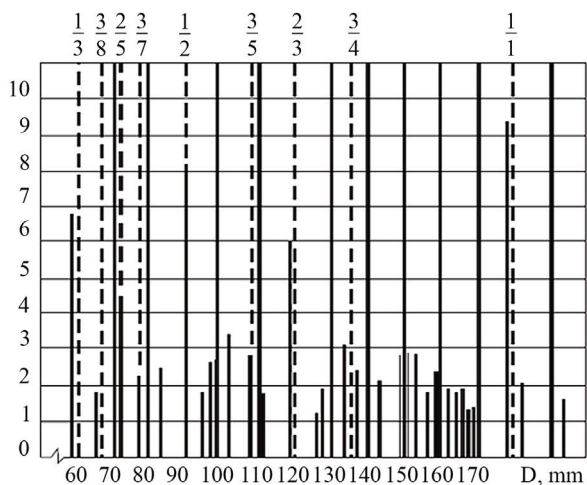

Fig. 9. Dependence of intensity of braid winding q on a winding diameter for machine PSK-225 SHG

Fig. 9 shows that the model quite accurately predicts the strongest formations observed at diameters of 60, 90, and 180 mm. Some differences can be attributed to the presence of slippage in the pair «bobbin – winding shaft» and to the subjectivity of the described experimental method.

Braid formations that form at multiplicity $m=2$ ($m/n=2/5$ and $m/n=2/3$) demonstrate lower intensity, which that is also consistent with the findings obtained from the analysis of mathematical models derived in chapter 4.1.

The formations that form when $m=3$ possess a less intensity than that at $m=2$ and merge with the rest formed at larger multiplicities. The magnitude of the intensity of braid winding for them is $q < 3$ threads/mm, that is, a 1-mm width of the defective structure hosts less than 3 threads. That indicates that such a formation is unlikely to have a significant impact on breakage at winding, on the process of laying

a thread, or other processes, which are negatively affected by braid winding.

The described procedure for the experimental evaluation of braid winding allows the quantification of the winding structure of packages, formed through different mechanisms of dispersion. It should be noted, however, that it has a fairly high degree of subjectivity and requires that a researcher should have certain skills. Indeed, when unwinding the packages, the pattern of a winding structure at the package surface changes constantly, and a researcher is required to demonstrate a certain reaction in order to timely terminate the unwinding process. In this case, the researcher may miss some formations considering them not significant. In this connection, there is a task to develop such a procedure that would make it possible to monitor the surface of winding at its continuous unwinding and to record indicators correlated with the number of threads in the braid. At the same time, the current package diameter must be measured and recorded.

6. Conclusions

1. It was established that the cause of defect formation in the structure of winding in the form of braid winding and tape winding is the multiplicity of thread guide motion periods and the bobbin rotation frequency, which made it possible to reasonably address the development of a method for estimating defects in winding.

2. We have formulated a generalized criterion, the number of turns, stacked sequentially at a distance not exceeding the specified one, for the estimation determination of defects in the winding structure that would make it possible to estimate their impact on quality of the package.

3. We have experimentally confirmed the negative effect of structure defects in the winding on suitability of packages for processing at subsequent operations. Thus, the breakage caused by defects in the winding is up to 22 % of the total breakage, on average.

4. We have constructed an estimation method to analyze the structure of winding that is generated without dispersing the braid structures, enabling the representation of results based on the normalized dimensionless indicators, comparing the structure of winding formed at different machines under different conditions of winding. In addition, it makes it possible to choose the rational structures of winding mechanisms.

5. We have constructed a calculation method to analyze the structure of winding that is generated with the dispersion of braid structures, enabling the quantification of effectiveness of their dispersion and finding the rational technological modes employing methods of multi-criteria optimization.

References

1. Model for Simulating Yarn Unwinding from Packages / Praček S., Pušnik N., Simončič B., Tavčer Petra F. // *Fibres and Textiles in Eastern Europe*. 2015. Vol. 23, Issue 2 (110). P. 25–32. URL: <http://www.fibtex.lodz.pl/article1407.html>
2. Liangxue L. Control System for Textile Winding Machine Convenient for Loading of Bobbin. IPC: B65H54/547, B65H63/00, B65H67/04, CN104386539 (A). 2015.
3. Shams Nateri A., Ebrahimi F., Sadeghzade N. Evaluation of Yarn Defects by Image Processing Technique // *Optik – International Journal for Light and Electron Optics*. 2014. Vol. 125, Issue 20. P. 5998–6002. doi: <https://doi.org/10.1016/j.ijleo.2014.06.095>
4. Rudovsky P. N. Influence of Parameters of the Winding Mechanism on Laying Coils in Tourniquet Formation // *News of Higher Educational Institutions, Technology of Textile Industry*. 1995. Issue 6. P. 108–111.

5. Real-time graphic visualization of filament band winding for fiber-reinforced cylindrical vessels / Fu J., Yun J., Kim J.-S., Jung Y. // *Journal of Composite Materials*. 2015. Vol. 50, Issue 16. P. 2165–2175. doi: <https://doi.org/10.1177/0021998315602325>
6. Li L. Control System for Textile Winding Machine Convenient for Loading of Bobbin: Pat. No. 104386539A CN. IPC: B65H54/547, B65H63/00, B65H67/04. No. 201410607590 CN. declared: 03.11.2014; published: 04.03.2015.
7. Ashhepkova N. S. Mathcad in the kinematic and dynamic analysis of the manipulator // *Eastern-European Journal of Enterprise Technologies*. 2015. Vol. 5, Issue 7 (77). P. 54–63. doi: <https://doi.org/10.15587/1729-4061.2015.51105>
8. Jhatial R. A., Peerzada M. H., Syed U. Optical Yarn Assessment System for Twist Measurement in Rotor-Spun Yarn // *Mehran University Research Journal of Engineering and Technology*. 2016. Vol. 34, Issue 1. P. 25–32.
9. Determining the dependences for calculating a conversion scale of profile height of the controlled packing surface / Nuriyev M. N., Seydaliyev I. M., Recebov I. S., Dadashova K. S., Musayeva T. T. // *Eastern-European Journal of Enterprise Technologies*. 2017. Vol. 2, Issue 1. P. 58–62. doi: <https://doi.org/10.15587/1729-4061.2017.96977>
10. Maag F. Spinnspulen mit der Stufenprazissionswicklung // *Textilindustrie*. 1985. Vol. 6. P. 416–420.
11. Nuriyev M. N., Musayeva T. T. Development of Algorithms Surface Recognition Forging Cross Winding // *Bulletin of NTU «KhPI». Series: Mechanical-technological systems and complexes*. 2016. Vol. 49, Issue 1221. P. 52–55.
12. Development of a Device for Continuously Monitoring the Parameters of the Winding Structure of Textile Bobbins / Nuriyev M., Ali Veliyev F., İnsaf Hamidov H., Aqagul Sailov R., Mahamad Seydaliyev I., Zargar Jabbarova G. // *Ingeniería solidaria*. 2018. Vol. 14, Issue 24. P. 1. doi: <https://doi.org/10.16925/v14i24.2183>
13. Nuriyev M. N. Destructive Methods of Controlling the Density Distribution of the Winding Body // *Progressive Technologies and Systems of Mechanical Engineering*. 2016. Vol. 4, Issue 55. P. 44–48.
14. Nuriyev M., Dadashova K., Radzhabov I. Development of methods for recognition of structural defects using package surface image // *ScienceRise*. 2016. Vol. 4, Issue 2 (21). P. 6–10. doi: <https://doi.org/10.15587/2313-8416.2016.66143>
15. Ganira Z. D., Nuriyev M. N. Formirovanie pakovok s sinusoidal'nym izmeneniyem skorosti nitevoditelya // *Izvestiya vysshih uchebnyh zavedeniy. Tekhnologiya tekstil'noy promyshlennosti*. 2017. Issue 2. P. 176–180.
16. Analysis of the formation of filament winding in terms of force interactions between threads / Nuriyev M., Veliyev F., Seydaliyev I. M., Dadashova K., Jabbarova G. Z., Allahverdiyeva I. // *Eastern-European Journal of Enterprise Technologies*. 2017. Vol. 6, Issue 1 (90). P. 11–18. doi: <https://doi.org/10.15587/1729-4061.2017.118961>
17. Musayeva T. T., Nuriyev M. N. Efficiency of Quality Management System's Application In The Enterprises of Light Industry // *International Journal of Humanities & Social Science Studies (IJHSS)*. 2016. Vol. II, Issue VI. P. 233–240. URL: <http://oaji.net/articles/2016/1115-1464938939.pdf>
18. Nuriyev M. N., Kiselev P. N. Razrabotka algoritmov avtomatizirovannogo opredeleniya edinichnyh pokazateley dlya ochenki defektov formy pakovok krestovoy namotki // *Uchenye zapiski AzTU. Seriya: Fundamental'nye nauki*. 2007. Issue 3. P. 19–22.
19. Denisov A. R., Kiprina L. Yu., Rudovskiy P. N. Primenenie metodov klaster'nogo analiza dlya kontrolya kachestva pakovok krestovoy namotki // *Izvestiya vysshih uchebnyh zavedeniy. Tekhnologiya tekstil'noy promyshlennosti*. 2006. Issue 4s. P. 111–113.