

За допомогою методів математичного моделювання та експериментально проведено дослідження різних типів мікрохвильових резонаторних вимірювальних перетворювачів з мікрозондовими сенсорними елементами коаксіального типу. Необхідність проведення таких досліджень пов'язана з їх широким застосуванням для локального неруйнівного контролю і діагностики електрофізичних характеристик мікро- та нанорозмірних об'єктів і структур.

При аналізі резонаторних вимірювальних перетворювачів з мікрозондовими елементами за основний критерій обрано досягнення максимальної добротності, яка визначає чутливість вимірювань. Досліджено структури вимірювальних перетворювачів на основі коаксіального резонатора, геометричні розміри якого плавно змінюються, резонаторів на основі відрізків регулярних хвильоводів, циліндричного резонатора. Також проведено дослідження мікрохвильових вимірювальних перетворювачів на основі гібридних нерегулярних об'ємних і планарних структур. Розглянуто характер розподілу електромагнітного поля в структурах перетворювачів, амплітудно-частотні характеристики та їх зміни при взаємодії із зовнішніми об'єктами. В результаті проведених досліджень виявлено можливості підвищення добротності для різних типів мікрохвильових резонаторних вимірювальних перетворювачів з мікрозондовими елементами до величин порядку 10^4 . Запропоновано, розроблено і досліджено практичні конструкції вимірювальних перетворювачів, які можуть бути використані як у скануючої мікрохвильової мікроскопії, так і в інших вимірювальних системах і комплексах. Розроблено і досліджено вимірювальний перетворювач на основі коаксіальної структури, який має резонанси в широкому діапазоні робочих частот. Розроблено і досліджено технологічно прості конструкції високодобротних резонаторних перетворювачів прохідного типу сантиметрового та міліметрового діапазонів довжин хвиль на основі відрізків регулярних хвильоводів. Експериментально доведено можливість створення високодобротного мікрохвильового перетворювача на основі гібридних нерегулярних структур, що збуджуються на вищих типах коливань. Виявлено сильний вплив характеристик елементів зв'язку на параметри резонаторних вимірювальних перетворювачів, який треба враховувати при їх практичному застосуванні. Результати досліджень, які були проведені, дозволяють розширити практику та галузі застосування методів локальної неруйнівної мікрохвильової діагностики малорозмірних об'єктів та структур

Ключові слова: мікрохвильова діагностика, резонаторний вимірювальний перетворювач, мікрозондова структура, скануюча мікрохвильова мікроскопія

UDC 621.385.6

DOI: 10.15587/1729-4061.2018.150510

STUDY INTO THE RESONATOR STRUCTURES WITH MICROPROBE SENSING ELEMENTS

I. Bondarenko

Doctor of Physical and Mathematical
Sciences, Professor,
Head of Department*

E-mail: ihor.bondarenko@nure.ua

A. Borodin

Associate Professor*

E-mail: aleksandr.borodin@nure.ua

Yu. Vasilyev

Assistant*

E-mail: yurii.vasilyev@nure.ua

V. Karnausenko

Associate Professor*

E-mail: vladimir.karnausenko@nure.ua

*Department of microelectronics,
electronic devices and appliances

Kharkiv National University

of Radio Electronics

Nauky ave., 14, Kharkiv,

Ukraine, 61166

1. Introduction

Microwave diagnostics is now commonly used as a method of non-contact examination and control over parameters in various materials and media [1–5]. One of the directions in the development of methods for microwave contact-free non-destructive diagnostics is the active application of microprobe structures, which make it possible to execute local control over the micro areas of examined objects at high spatial resolution [1, 6]. Such possibilities are increasingly popular due to the necessity to explore the micro- and nanostructures of modern electronics, bio-objects, as well as materials and structures, constructed based on nanotechnologies.

Resonant measuring transducers (RMT) with aperture and probe sensing elements enable high-sensitivity control at high locality of measurements [1, 6, 7]. Information on the investigated objects in this case is contained in the changes in the quality factor and resonance frequency of RMT, predetermined by the interaction between electromagnetic fields, formed by the aperture or probe sensing elements, and the local areas or structures in tested objects.

For RMT of the aperture type, a conversion coefficient magnitude is defined mainly by the character and extent of interaction between a resonator's fields and an object through the aperture.

In recent years, given the development of scanning probe microscopy methods and the requirement to examine param-

eters of various objects at the micro- and nano-dimensional level, a new direction of diagnostics has emerged, related to the scanning microwave microscopy (SMM) [1, 6, 8–11]. Underlying SMM is the near-field interaction between microwave electromagnetic fields, formed by microprobe structures, and the localized (a degree of localization is defined by the size and design of a microprobe) surface and near-surface layers in tested materials [12, 13]. Consequently, a feature of RMT, employed at SMM, is the presence of microprobe structures whose geometrical dimensions and shape largely define the functional and metrological capabilities of SMM in general.

Such a microprobe structure is typically a small-size waveguide or coaxial emitter (a micro-antenna), which is directly included in the resonator or connected to it through a coupling element. In this case, it is necessary to take into consideration the character of interaction between a probe structure and the components of the electromagnetic field of the resonator. The structure and technology of resonator fabrication must ensure its maximum quality factor at excitation on the kind of oscillations, suitable for pairing with a microprobe structure. The higher the quality factor of RMT, the more accurate the measured changes in the resonance frequency and the higher sensitivity to the insertion losses.

Maximum values for the natural quality factor are typically achieved using the volumetric microwave resonators ($\sim 10^3 \dots 10^4$, depending on the type of oscillations and the material used).

2. Literature review and problem statement

The measuring transducer's parameters largely define measuring capabilities of the system as a whole. At the same time, the issues related to analysis of the structures and characteristics of RMT with microprobes have not been investigated in detail. Paper [4] schematically described a resonance near-field sensor, failing to provide a detailed analysis into its characteristics. In work [7], a quarter-wave coaxial resonator is used as a sensor, at whose open end a protruding central conductor is employed for near-field sensing. The structure of such a sensor can be fabricated quite easily, though the quality factors of coaxial resonators are typically not very high (a maximum of 10^3), while the application of the broadband properties of coaxials is impossible because its size is limited to one quarter of a wave. The authors of [8] employed as a sensor, similar to many studies into SMM, a section of a regular coaxial line, whose open end performs the functions of a probe. Such a structure could operate under resonance and non-resonance modes. In this case, the quality factor under a resonance mode will be low (less than 10^3), and the sensitivity of measurements will significantly (by orders of magnitude) deteriorate under a non-resonance mode. Paper [12] reports results of numerical modelling studies into resonant probes for SMM, which are suggested for the further design. In addition, the authors considered probes of only one coaxial type. Work [14] explored a coaxial cone sensor for micro-diagnosing, but it also lacks complete results from the study into characteristics of practical structures of such sensors. Paper [15] applied a resonant probe based on the section of a waveguide with a coaxial structure introduced to it, whose outer open end is the near-field probe. The sensor is built on an adjustable coaxial-waveguide junction. Such a structure can be driven

to a resonance mode using a movable short-circuit piston; its quality factor, however, will be low due to the strong connection to external circuits.

So far, studies into microwave local diagnostics have employed the microwave measuring sensors whose designs were proposed during early years of the formation of this direction. It is clear that there are not enough publications that address the analysis of various types of measuring sensors based on resonant structures with microprobe sensing elements, or deal with the selection of directions to improve their performance and extend the scope of their application.

3. The aim and objectives of the study

The aim of this study is to design, investigate, and analyze the characteristics of microwave resonant measuring transducers with microprobe sensing elements in order to enable local diagnosing and control over parameters of small-sized objects.

To accomplish the aim, the following tasks have been set:

- to define the conditions to maximize the quality factor of RMT;
- to estimate the impact of coupling elements' parameters on the transfer function and quality factor of RMT;
- to assess the impact of the tested object's parameters on the characteristics of RMT.

4. Research and analysis of RMT characteristics

4.1. Factors influencing the RMT characteristics

RMT is typically composed of a resonator, coupling elements between the resonator and a measuring circuit, and a probe structure.

The characteristics of RMT will, accordingly, be defined in general by the parameters and structure of its elements, as well as by the methods for their alignment and adjustment.

A working quality factor of RMT is mainly dependent on the quality factor of the resonator.

The resonator, which is employed as a measuring transducer at SMM, must include the coupling elements in order to connect it to the measuring circuit, as well as a device or an element to couple it to the microprobe structure. Given this, the losses in a resonator grow while its quality factor deteriorates:

$$Q_n = \frac{Q_0}{1 + \sum_i \beta_i}, \quad (1)$$

where Q_n is the loaded quality factor of the resonator; $\beta_i = \frac{P_{\text{bmi}}}{P_p}$ is the magnitude of the coupling coefficient; $\frac{P_{\text{bmi}}}{P_p}$ is the average power of losses in the respective coupling element or the power emitted from the resonator via a respective coupling element when a signal source is disabled; P_p is the average power of losses in the resonator itself.

A probe structure is typically a section of the coaxial line, at the one side of which there is a sharpened internal conductor of the line used as a probe, and at the other side of which there is a coupling element to the resonator in the form of a pins or a loop. In some cases, given the smooth junction, the natural structure of a resonant transducer is transformed into a probe (for example, in coaxial reso-

nant transducers [1, 6, 8, 12, 14]). This device must ensure effective interaction between a field, generated using the probe structure, and the tested object, and the receipt of the waves reflected and(or) re-remitted by the object. In this case, a microprobe structure must be a mutual device with a fairly large (~1) value for the coefficient of coupling with the resonator. The magnitude of the coupling coefficient is usually mechanically regulated by the degree of immersion of the loop or pin coupling element to the resonator's volume. Accordingly, at such values for the coupling coefficient, the loaded quality factor of RMT will decrease nearly two-fold in comparison with its own value (1) only at the expense of a microprobe device.

The basic condition for the operation of the system that forms a measuring microwave signal is to obtain at the microwave detector a value for the signal that is sufficient for the subsequent processing.

An impact of RMT on the signal's magnitude at a detector will be determined by the transfer ratio.

A decrease in coupling coefficients at the pass-through connection leads to an increase in the transient damping of RMT, while at the reflecting connection the optimal mode of operation is at $\beta=1$, when the amplitude of the signal reflected from the resonator is minimal.

Selecting the values for coupling coefficients that would be appropriate to enable the operation of a system to form the measuring microwave signals leads to an additional decrease in the value of the loaded quality factor of RMT.

When using the measuring system, wide-range in frequency, and RMT that operates at multiple resonance frequencies, located over a wide range of frequencies, it is preferable to employ the coaxial coupling elements with a measuring system, which have the better range properties. When applying a single-resonance RMT, it is better to use the waveguide coupling elements that demonstrate lower losses, simpler in their structure, and easier to manufacture.

Thus, it is necessary to carry out analysis and undertake a research into the component structures of RMT, which include a resonator part, a probe structure, coupling elements to a measuring circuit.

Results of an analysis would make it possible to define the set of possible variants for constructing RMT and their constituent parts.

Taking into consideration the application of a coaxial microprobe structure, we have chosen the following RMT types for analysis:

- based on a conical quarter-wave coaxial resonator;
- based on prismatic rectangular resonators at oscillation types of H_{10n} ;
- based on a cylindrical resonator at oscillation types of H_{011} ;
- based on irregular structures.

4. 2. Studying the conical quarter-wave coaxial resonator

Coaxial structures at length $L = n \cdot \lambda / 4$ and at a large value of magnitude n can be excited over a large number of resonance frequencies in a wide frequency range. In this regard, we investigated RMT based on a coaxial structure (Fig. 1).

A feature of the structure of RMT in this case is the use of a coaxial resonator excited by a wave of the TEM type. A transition to the probe occurs via a smooth transformation of the resonator's coaxial structure into a coaxial probe structure. The advantage of this RMT is the possibility of obtaining resonances at different frequencies over a wide range of working frequencies (at electrical lengths of the coaxial structure multiple to the odd number of quarters of wavelengths). For example, at the length of the resonator of ~83 mm, the resonances are observed at frequencies: ~0.904 ($L=\lambda/4$); ~2.71 ($L=3 \cdot \lambda/4$); ~4.52 ($L=5 \cdot \lambda/4$); ~6.325 ($L=7 \cdot \lambda/4$); ~8.132 ($L=9 \cdot \lambda/4$); ~9.94 ($L=11 \cdot \lambda/4$); ~11.75 ($L=13 \cdot \lambda/4$); ~13.55 ($L=15 \cdot \lambda/4$); ~15.36 ($L=17 \cdot \lambda/4$) GHz, etc.

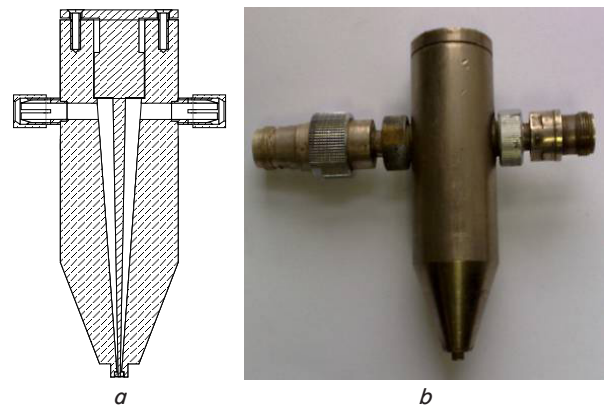

Fig. 1. Resonant measuring transducer based on a conical quarter-wave resonator: a – schematic; b – practical implementation

The shortcomings of such RMT include low values for the quality factor of working resonances, as well as the dependence of characteristics of the coupling elements on change in the operating frequency.

AFK of the RMT experimental prototype based on a conical quarter-wave resonator is shown in Fig. 2.

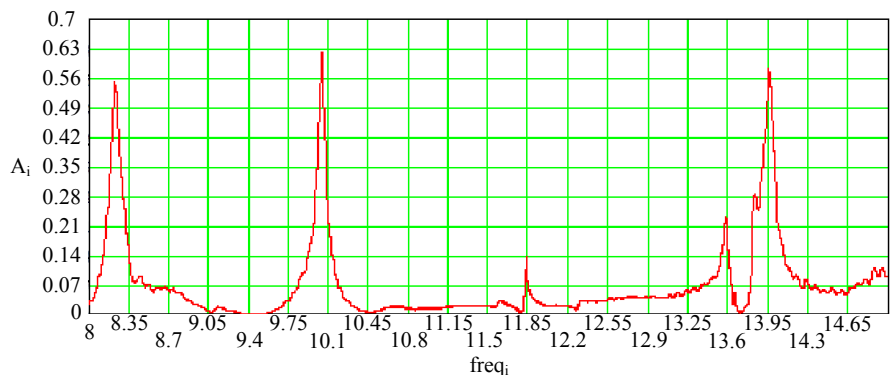

Fig. 2. AFK of RMT based on a conical quarter-wave coaxial resonator in the frequency range of 8...5 GHz

4. 3. Studying RMT based on prismatic rectangular resonators at oscillation types of H_{10n}

Table 1 gives theoretical estimation of the quality factor values for copper prismatic rectangular resonators excited at oscillation types of H_{10n} .

One can see that the maximum values for a quality factor are demonstrated by cubic resonators, while the resonators based on segments of standard rectangular waveguides also provide their high values. The advantage of such resonators

is the ease of manufacture and conjugation with the wave-guide transmission lines. Using the rectangular waveguides and operation at the lowest basic wave type makes it possible, in addition, to ensure a single-mode regime over the working range of frequencies.

A typical distribution of the electric field and the physical appearance of RMT based on rectangular waveguides are shown in Fig. 3 [16].

The experimental samples of RMT based on regular waveguide structures (Fig. 3, b) demonstrated the quality factors of $\sim 1.7 \cdot 10^3$ at frequency 9.89 GHz and oscillation type H_{103} , $\sim 2.7 \cdot 10^3$ at frequency 35.88 GHz at oscillation type H_{107} . The obtained quality factor values are naturally lower than those yielded from theoretical estimation and model experiments, but they are significantly higher than those derived for RMT based on a conical quarter-wave coaxial resonator.

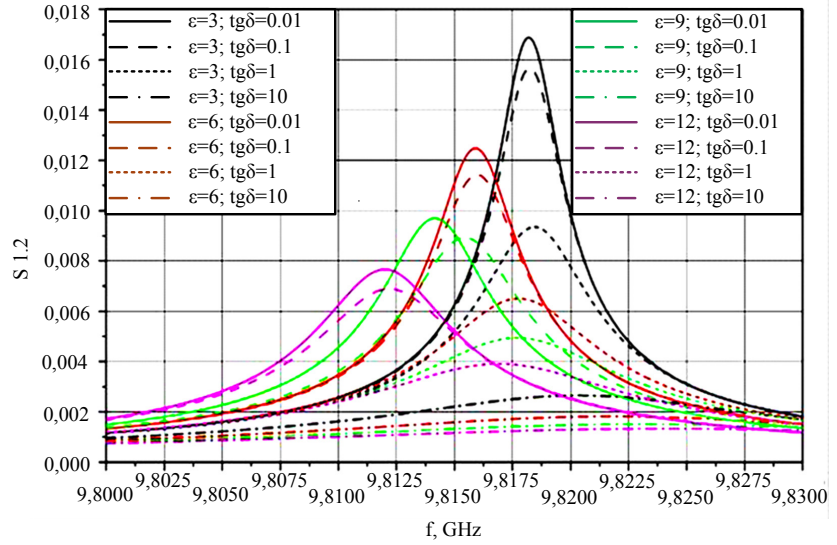

Fig. 4. Effect of electrophysical parameters of an object on f_p and Q of RMT

4. 4. Studying RMT based on a cylindrical resonator at oscillation type of H_{011}

Despite the great diversity of resonant elements used in RMT at SMM, the maximum quality factor value can be achieved in the cylindrical resonators excited on oscillation type of H_{01n} . The estimated value for a quality factor of such resonators reaches 10^4 and larger. Even when such a resonator is connected to coupling elements and a probe structure, the quality factor magnitude of such RMT should be large enough.

In this regard, it appears appropriate to run an analysis of the elements and structure of RMT based on a cylindrical resonator at oscillation type of H_{011} . The structure and physical appearance of such RMT are shown in Fig. 5.

Table 1
Parameters of volumetric prismatic resonators

F_0 , GHz	Oscillation type	Dimensions, mm	Q_0
10	H_{101}	$a=b=L=21$	$\sim 1.61 \cdot 10^4$
	H_{101}	$a=23, b=10, L=20$	$\sim 5.41 \cdot 10^3$
	H_{103}	$a=23, b=10, L=60$	$\sim 6.027 \cdot 10^3$
36	H_{101}	$a=b=L=16.4$	$\sim 8.485 \cdot 10^3$
	H_{101}	$a=7.2, b=3.4, L=5$	$\sim 3.605 \cdot 10^3$
	H_{105}	$a=7.2, b=3.4, L=25$	$\sim 4.138 \cdot 10^3$

The results of analysis into the influence of electro-physical parameters of the tested object on f_p and Q of RMT are shown in Fig. 4.

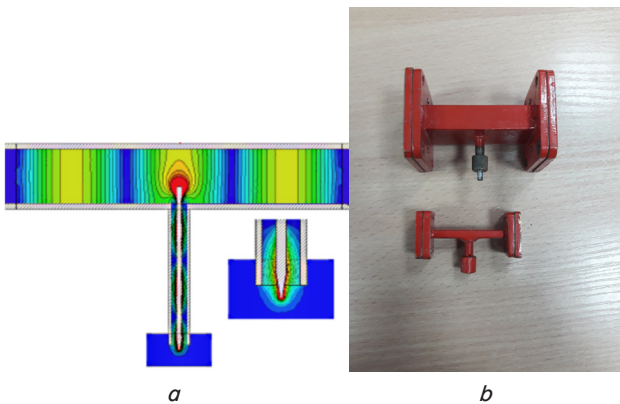

Fig. 3. Resonant measuring transducer based on segments of rectangular waveguides: a – field distribution; b – physical appearance of RMT for the centimeter and millimeter wavelength ranges

It follows from charts in Fig. 4 that RMT based on the resonator at a segment of the rectangular waveguide, given the optimal execution of its elements, makes it possible to effectively register the values for electrophysical parameters of the tested objects in a wide range of their changes.

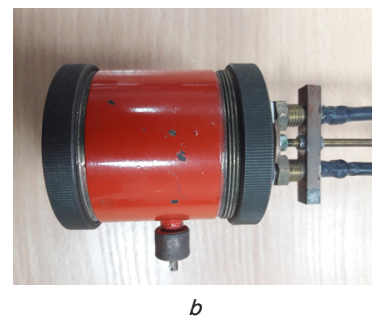
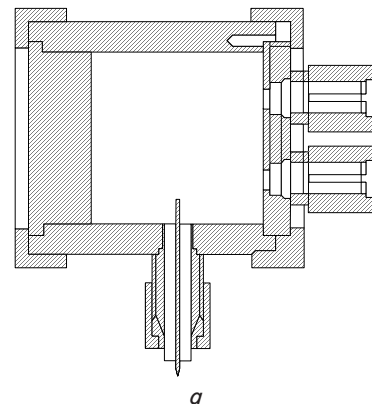

Fig. 5. Resonant measuring transducer based on a cylindrical resonator excited at oscillation type of H_{011} : a – schematic; b – practical implementation

The results of calculations performed for cylindrical copper resonators excited at oscillation type of H_{011} , are given in Table 2.

Table 2

Values for f_p and Q (oscillation type H_{011})

Filler	Dimensions, mm	f_p , GHz	Q_0
Vacuum (air)	$d=h=39.55$	10.10	$\sim 3 \cdot 10^4$
Fluorine plastic	$d=h=26.5$	10.66	$\sim 4 \cdot 10^3$

Calculation for the resonator filled with a dielectric was performed in order to elucidate a possibility to reduce dimensions of RMT while maintaining a high quality factor. The results obtained show that even in the case of using a fluorine plastic of $\text{tg}\delta \sim 10^{-3}$ as a filler the quality factor is greatly reduced due to losses in the dielectric. The quality factor of such a resonator becomes comparable to the quality factors for the resonators based on segments of waveguides, which are much simpler in terms of their structure and fabrication. When applying a dielectric with smaller losses the quality factor could be improved, however, such dielectrics are less manufacturable.

A field distribution in the aperture part of a probe structure also strongly depends on the geometry of the protruding central conductor. Its sharpening leads to an increase in the degree of localization of the field in the aperture of the probe structure of RMT. Changing the magnitude of losses in a sample leads to a marked change in the RMT quality factor, while the existence of a gap – to the field localization and weakened interaction with the sample.

Fig. 6 shows the distribution of fields in the aperture part of a probe structure of RMT in the presence of a sample ($\text{tg}\delta=0.01$; $\epsilon=12$) and the existence and absence of a gap between a conical probe and the sample.

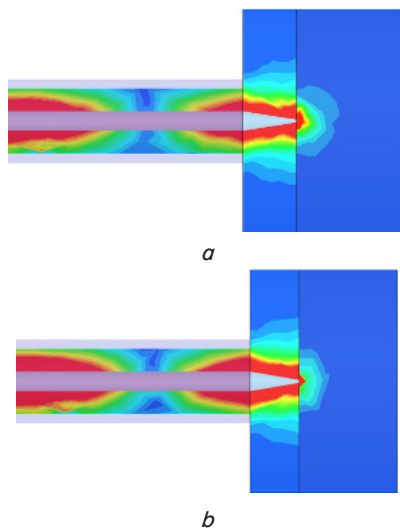

Fig. 6. Field distribution in the aperture part of a probe structure of RMT in the presence of a sample ($\text{tg}\delta=0.01$; $\epsilon=12$): *a* – without a gap; *b* – a gap of $1 \mu\text{m}$

In the course of an experimental study into RMT made from brass, whose structure and physical appearance are shown in Fig. 5, at a frequency of 9.9955 GHz we obtained the quality factor of $\sim 9.52 \cdot 10^3$.

Thus, our study has shown that RMT based on a cylindrical resonator excited at oscillation type of H_{011} , makes it

possible to provide for a high initial quality factor quality of RMT in general and, consequently, to improve the sensitivity of measurements.

4. 5. Studying RMT based on irregular structures

It is possible, in a conical coaxial resonator, in addition to the TEM wave oscillations (Fig. 7, *a*), to induce other types of oscillations (Fig. 7, *b*). The quality factor of the resonator, obtained in this case, is several times greater than that for the TEM wave oscillations. Variation in the cone geometry, its length and the ratio of the respective diameters of conductors, can provide the required value for a resonance frequency.

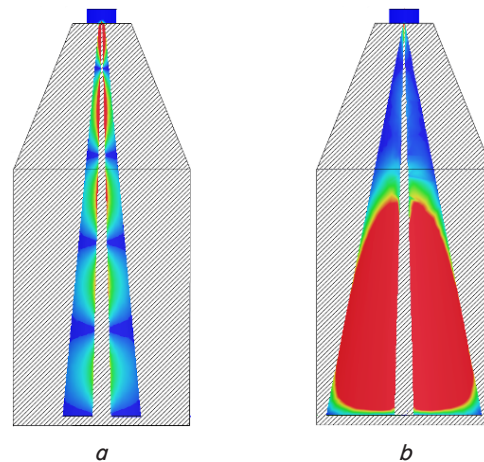

Fig. 7. Structures of fields at resonances in conical coaxial resonators: *a* – quarter-wave resonance (TEM, $L=9\lambda/4$, $f_p=8.32 \text{ GHz}$, $Q=1.55 \cdot 10^3$); *b* – oscillations of the higher type wave ($f_p=7.85 \text{ GHz}$, $Q=1.15 \cdot 10^4$)

An analysis of the structure of electromagnetic fields reveals that the type of oscillations shown in Fig. 7, *b* can be identified with the lowest type of oscillations H_{111} in a cylindrical resonator [17–19].

By changing the sizes and geometry, it is possible to manage the excitation of other types of high-quality oscillations. In this case, one can obtain the values for quality factors and resonance frequencies that are higher than those for the oscillation type of quasi – H_{111} .

Enabling the operation of the examined resonant irregular structures at the selected type of oscillations is a fairly complex electrodynamic and technical challenge, since such a structure demonstrates a multi-mode character and can be excited at different types of oscillations in the working range of frequencies. In this case, both the resonances of an n-quarter-wave coaxial resonator and resonances at the higher types of oscillations could be induced.

The number of possible resonances in the examined structure could be reduced by choosing the structure and location to connect the coupling elements, intended to excite the resonance selected (Fig. 8).

We have experimentally validated results from numerical simulation using an experimental prototype whose physical appearance is shown in Fig. 9.

RMT with a central coaxial conductor demonstrated the resonance at a frequency of 9.98 GHz with a quality factor of $\sim 1.3 \cdot 10^3$; RMT without a coaxial conductor demonstrated the resonance at a frequency of 9.5 GHz with a quality factor of $\sim 4 \cdot 10^3$. Coupling between the high-quality type

of oscillations and a probe part is enabled by placing an axial conductor in the beyond-the-limit section of the cone.

Thus, the irregular coaxial structures, excited at the highest types of oscillations, can be successfully applied in order to construct high-quality RMT with quite widely spaced resonances.

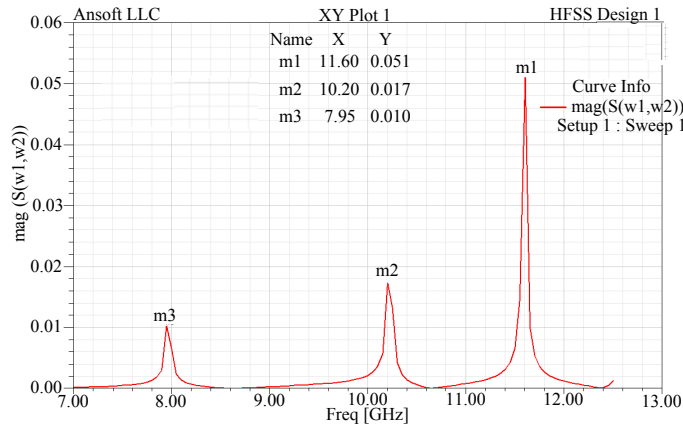

Fig. 8. AFK of RMT based on an irregular coaxial structure



Fig. 9. Physical appearance of the experimental prototype of RMT based on an irregular coaxial structure

The implementation of such structures has become possible owing to the development of methods for numerical programmed simulation of electromagnetic processes and devices. Determining specific geometric dimensions of structures for the assigned frequency value implies sorting out model variants followed by experimental adjustment.

Another option of RMT implementation for the purpose of local diagnostics is to use planar (strip and microstrip) structures [20]. Resonance properties are provided by the half-wave or ring resonances; the localization of an interaction field – by sharpening the end of a strip structure (Fig. 10).

Modelling experiment has shown that RMT retain at half-wave segments of lines their resonant properties despite the introduction of sharpened elements to their topology. In this case, the sharpening reveals the elevated field intensity, especially for the case of an irregular structure (Fig. 10, b). At the same time, the quality factor for such RMT is low (only a few dozen).

As regards RMT based on a ring resonator (Fig. 10, d), we have identified a possibility to obtain higher quality factor values (Fig. 11). One can see (Fig. 11) that in the frequency range of 7...11 GHz there are three resonant responses from the

examined RMT. In this case, for all resonant responses there is a strong dependence of their shape on the samples' $tg\delta$ near the tip, which indicates an opportunity to use this type of transducers for diagnosing different materials and objects. The highest sensitivity to a change in the magnitude of losses in the sample is observed at frequencies of 7.64 GHz and 10.11 GHz.

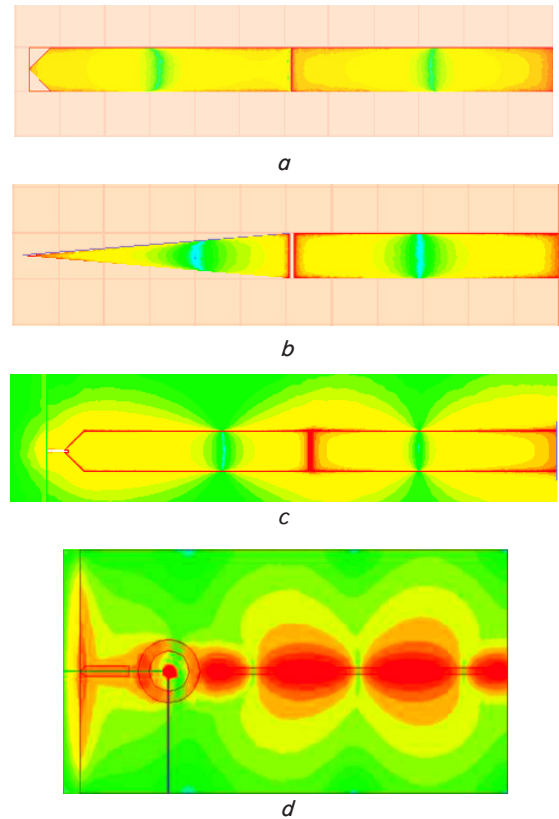

Fig. 10. Topology and distribution of electric fields in RMT based on strip structures: a – a line half-wave segment with sharpening, b – a line half-wave segment in the form of an irregular structure, c – a line half-wave segment with sharpening and a tip, d – a ring resonator with a connected line's segment with sharpening

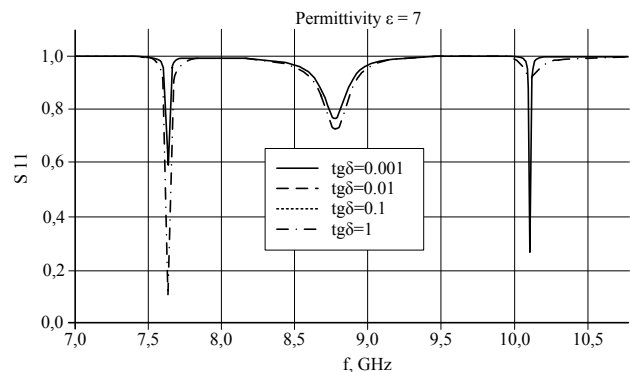

Fig. 11. AFK of reflectivity coefficient for RMT based on a ring standing wave resonator in the frequency range of 7...11 GHz

Variation in the magnitude of permittivity of the sample within 1...12 shows an increase in the sensitivity of the examined RMT to the magnitude of losses in the sample with an increase in ϵ .

RMT based on strip- and microstrip structures could be used to construct the integrated devices that include an electronic system both for the formation and the pre-processing of signals. The design features of their microprobe part show the prospect to construct a universal microprobe that could be used simultaneously for microwave, atomic-force and tunnel microscopy within a single measuring complex.

5. Discussion of results of studying the microwave resonant measuring transducers with microprobe sensing elements

Our study that combined numerical modelling and practical experimental approaches has made it possible to run a more reliable analysis into opportunities and prospects for improving various types of RMT with microprobes. A comprehensive approach allows us, on the one hand, to assess the character of change in the information parameters (resonance frequency and quality factor) of RMT with microprobes during interaction with the tested objects, and to reveal, on the other hand, the structure of fields in the region of micro-dimensional near-field interaction (Fig. 3, a, 6, 7, 10). The task on determining the structure of fields in the region of a microprobe's tip can at present be solved only by methods of numerical simulation.

The results of research are the basis for the selection of design for sensors when resolving the challenges related to constructing high-resolution diagnostics systems for scientific studies and in order to enable technological processes at the micro- and nano-structure level.

A promising avenue to advance the research is to construct RMT based on micro-resonators in the THz range, as well as devices that would exert intensive micro- and nano-local electromagnetic influence on objects with a different character.

6. Conclusions

1. The high quality factor (up to 10^3 – 10^4) of RMT intended for local diagnostics is provided when using volumetric resonators at segments of regular transmission lines, excited at the basic types of waves. The high-performance quality factor (10^3 and above) could be also achieved by employing the hybrid irregular resonance structures.

2. The influence of characteristics of the elements that connect the system of measurements on the parameters of all types of RMT could in some cases become critical and substantially degrade the metrological parameters of the system in general. It is necessary to optimize the characteristics of coupling elements to enable the joint work of both RMT and a system for measuring and processing information signals.

3. All the investigated types of RMT make it possible to register changes in the electrophysical parameters of objects subject to diagnosing. The sensitivity of measurements depends on the quality factor and the magnitude of connection between a microprobe structure with a resonator and a tested object. When examining objects with large losses, this coupling must be reduced. Given this, and with respect to the second point of our conclusions, there is the task to construct such coupling elements that could be adjusted during measurements.

References

1. Microwave Electronics: Measurement and Materials Characterization / Chen L. F., Ong C. K., Neo C. P., Varadan V. V., Varadan V. K. John Willy & Sons, Ltd, 2004. 537 p. doi: <https://doi.org/10.1002/0470020466>
2. Fedyunin P. A. Mikrovolnovaya termovlagometriya. Moscow: «Izdatel'stvo Mashinostroenie-1», 2004. 208 p.
3. Lisovskiy V. V. Teoriya i praktika vysokochastotnogo kontrolya vlazhnosti sel'skohozyaystvennykh materialov. Minsk: UOBGATU, 2005. 292 p.
4. Haase N., Jacob A. F. Dielectric contrast measurements on biological substances with resonant microwave near-field sensors // International Journal of Microwave and Wireless Technologies. 2013. Vol. 5, Issue 03. P. 221–230. doi: <https://doi.org/10.1017/s1759078713000469>
5. Multimode near-field microwave monitoring of free water content of skin and imaging of tissue / Lofland S. E., Mazzatenta J. D., Croman J., Tyagi S. D. // Physics in Medicine and Biology. 2007. Vol. 52, Issue 5. P. 1295–1301. doi: <https://doi.org/10.1088/0031-9155/52/5/006>
6. Anlage S. M., Talanov V. V., Schwartz A. R. Principles of Near-Field Microwave Microscopy // Scanning Probe Microscopy. 2007. P. 215–253. doi: https://doi.org/10.1007/978-0-387-28668-6_8
7. Near-field microwave microscope measurements to characterize bulk material properties / Imtiaz A., Baldwin T., Nembach H. T., Wallis T. M., Kabos P. // Applied Physics Letters. 2007. Vol. 90, Issue 24. P. 243105. doi: <https://doi.org/10.1063/1.2748307>
8. Broadband dielectric microwave microscopy on micron length scales / Tselev A., Anlage S. M., Ma Z., Melngailis J. // Review of Scientific Instruments. 2007. Vol. 78, Issue 4. P. 044701. doi: <https://doi.org/10.1063/1.2719613>
9. High Resolution Scanning Microwave Microscopy for Applications in Liquid Environment / Farina M., Di Donato A., Mencarelli D., Venanzoni G., Morini A. // IEEE Microwave and Wireless Components Letters. 2012. Vol. 22, Issue 11. P. 595–597. doi: <https://doi.org/10.1109/lmwc.2012.2225607>
10. Haddadi K., Glay D., Lasri T. A 60 Ghz Scanning Near-Field Microscope With High Spatial Resolution Sub-Surface Imaging // IEEE Microwave and Wireless Components Letters. 2011. Vol. 21, Issue 11. P. 625–627. doi: <https://doi.org/10.1109/lmwc.2011.2167744>

11. Bondarenko I. N., Gordienko Yu. E., Larkin S. Yu. Systems of information signals shaping in cavity microwave microscopy // Proc. of 19th International Crimean Conference Microwave & Telecommunication Technology (CriMiCo'2009). 2009. P. 563–564.
12. The theoretical aspects of modelling and designing of resonator probes for scanning microwave microscopy / Gordienko Yu. A., Larkin S. Yu., Lepikh Ya. I., Lenkov S. V., Procenko V. O., Vakiv M. M. // Sensor Electronics and Microsystem Technologies. 2011. Vol. 2. P. 97–107.
13. Chisum J. D., Popovic Z. Performance Limitations and Measurement Analysis of a Near-Field Microwave Microscope for Nondestructive and Subsurface Detection // IEEE Transactions on Microwave Theory and Techniques. 2012. Vol. 60, Issue 8. P. 2605–2615. doi: <https://doi.org/10.1109/tmtt.2012.2201739>
14. Gordienko Yu. E., Larkin S. Yu., Ishchenko A. L. Harakteristiki koaksial'nogo konusnogo SVCh datchika dlya mikrodiagnostiki ob'ektov // Radiotekhnika. 2010. Issue 162. P. 35–40.
15. Nondestructive high spatial resolution imaging with a 60 GHz near-field scanning millimeter-wave microscope / Kim M., Kim J., Kim H., Kim S., Yang J., Yoo H. et. al. // Review of Scientific Instruments. 2004. Vol. 75, Issue 3. P. 684–688. doi: <https://doi.org/10.1063/1.1646735>
16. Resonant measuring trasducers on the basis of typical cavity resonators / Bondarenko I. N., Vasiliev Yu. S., Prokaza A. M., Troitski S. I. // Proc. of 22nd International Crimean Conference Microwave & Telecommunication Technology (CriMiCo'2012). 2012. P. 568–569.
17. Bondarenko I. N., Galich A. V., Troitski S. I. High-Q modes in irregular hybrid structures // Telecommunications and Radio Engineering. 2013. Vol. 72, Issue 19. P. 1747–1753. doi: <https://doi.org/10.1615/telecomradeng.v72.i19.30>
18. Cone-shaped resonator the high-order mode oscillation transducers / Bondarenko I. N., Galich A. V., Slipchenko N. I., Troitski S. I. // 2012 22nd International Crimean Conference “Microwave & Telecommunication Technology”. 2012. P. 565–567.
19. Bondarenko I., Galich A. Resonant irregular hybrid structures // 2016 13th International Conference on Modern Problems of Radio Engineering, Telecommunications and Computer Science (TCSET). 2016. doi: <https://doi.org/10.1109/tcset.2016.7452007>
20. Bondarenko I. N., Galich A. V. Measuring resonant transducers on the basis of microstrip structures // Telecommunications and Radio Engineering. 2015. Vol. 74, Issue 9. P. 807–814. doi: <https://doi.org/10.1615/telecomradeng.v74.i9.60>