

STUDYING THE MUTUAL INTERACTION OF HYDRAULIC CHARACTERISTICS OF WATER- DISTRIBUTING PIPELINES AND THEIR SPRAYING DEVICES IN THE COOLERS AT ENERGY UNITS

N. Bosak
PhD*

V. Cherniuk
Doctor of Technical Sciences,
Head of Department*

I. Matlai
PhD*

E-mail: i.matlay@gmail.com

I. Bihun
Postgraduate student*

*Department of Hydraulic and
Sanitary Engineering

Lviv Polytechnic National University
S. Bandery str., 12, Lviv, Ukraine, 79013

Основою для аналітичних досліджень взяті результати гідравлічних випробувань бризкальних форсунок для змішувального (водоструменевого) конденсатора пари турбогенератора теплової електростанції. Робота виконувалась на етапі пускових операцій ТЕС. Такі гідравлічні випробування виконані співавторами на етапі пускових операцій для Разданської ТЕС (Вірменія). ТЕС розміщена в маловодному гірському регіоні і її особливістю є: сухе охолодження циркуляційної води в радіаторних градирнях; оснащеність конденсатором пари змішувального типу.

Основним завданням гідравлічних досліджень було: визначити фактичну пропускну здатність, знайти коефіцієнт витрати форсунок для конденсатора пари, а також виконати аналіз їх роботи в умовах вакууму в конденсаторі.

Досліджувались форсунок двох типорозмірів діаметром 13 мм та 15 мм з двома отворами для розприскування охолоджувальної води в паровому просторі конденсатора.

Досліджуючи гідравлічні характеристики $Q=f(H)$ заводських форсунок розміщених в кінці водорозподільного трубопроводу було виявлено, що діаметр отвору форсунок істотно не впливав на витрату води при однакових напору води. Такий результат був наслідком того, що отримано характеристику трубопроводу, а не бризкального апарату.

Подальші гідравлічні дослідження форсунок виконані на спеціальному лабораторному стенді.

Встановлено, що в умовах вакууму в конденсаторі пари пропускну здатність форсунок буде вищою ніж в атмосферних умовах. Але в замкнутій системі циркуляційного водопостачання загальна витрата води форсунками буде рівною подачі охолоджувальної води насосами даної системи. Тобто подача охолоджувальної води в конденсатор суттєво не зміниться.

Досліджено також можливість збільшення подачі води в конденсатор для підвищення енергетичних показників. Виконаний аналіз показує неможливість суттєвого збільшення подачі води в конденсатор турбіни шляхом збільшення діаметрів отворів бризкальних форсунок. Адже це не призводить до суттєвого зменшення загальних втрат напору води і подачі циркуляційних насосів в систему охолодження пари в конденсаторі турбіни

Ключові слова: бризкальний апарат, водорозподільний трубопровід, охолодник води і пари електростанції, напори і витрати

1. Introduction

Water-distributing pipeline systems with spraying nozzles are a technological component in various sectors, particularly at facilities for cooling technical water at TPP and NPP. At TPP and NPP, the networks of pipes to supply and distribute water are used as elements in the tower and fan coolers, spraying pools, as well as steam condensers of mixing type.

The temperature of cooled technical water significantly depends on specific hydraulic load across the cooling area. That is why the uniformity of spraying hot water over the area of a cooling tower and a sprayer, as well as the size of its drops, are an important factor, along with air parameters, for cooling technical water in a cooling tower.

At the initial stage of hydraulic research into the nozzles of a steam condenser of mixing type we obtained very close

values for the flow rate of water for two different dimensions of nozzles. This can be explained by the prevailing influence of the hydraulic characteristics of a pipeline.

The relevance of this work is in determining the mutual influence of hydraulic characteristics of water-distributing pipelines (WDP) and their spraying devices in the coolers at enterprises' circulating water supply systems.

2. Literature review and problem statement

General-purpose research and development studies, industry procedures, and scientific papers have addressed the design and hydraulic calculation of WDP with spraying devices. Hydraulic calculation of a pipeline system for cooling technical water at cooling towers defines the diameter of the main and distributing pipes with the required water head, as

well as the uniform spraying of water over a cooling tower's area. Water-distributing pipelines at TPP are designed to feed water in a stepless manner via technological condensers and further on to the spraying devices at cooling systems.

The sectoral procedure to design cooling towers [1] defines the base for technological calculations and structural features of cooling towers. For example, for a cooling tower, the estimated water flow rate along a main waterpipe is taken to be equal to 1.5...2.0 m/s, while that along distributing pipelines – in the range of 0.8...1.5 m/s. Specific hydraulic load q_c over a cooling tower's area is determined from technological calculations and is about 8–12 m³/(m²·h), depending on the type of a sprayer, or 251–419 MJ/(m²·h) [1]. However, procedure [1] does not give detailed recommendations on the hydraulic calculation of WDP and nozzles.

In cooling towers, the common systems are cooling water supply with a central riser, the main and distributing (working) pipelines. WDP at tower coolers can include a one-circuit or two-circuit systems [2]. As regards the latter systems, the mutual influence of hydraulic characteristics of spraying devices and their WDP is less significant.

To determine the diameters of pipes for distributing systems at cooling towers, the estimated formula that was originally used had been derived from the Bernoulli equation for a stationary flow of liquid with variable water flow rate lengthwise the distributing pipelines. The main pipelines for a system of circulating water supply with cooling towers are calculated based on a procedure for long pipelines. And the modules of distributing pipelines with spraying devices are calculated mainly using a procedure for short pipelines. To simplify calculations and ensure a uniform hydraulic load over a cooling tower's area, boundary conditions [3] were accepted regarding a change in the diameters of pipelines and risers at WDP for different types of cooling towers.

The functional dependences for calculating WDP at cooling towers [3], in addition to the specific hydraulic load q_c over a cooling tower's area, are supplemented with an indicator for the non-uniform distribution of water over the sprayer of a cooling tower's water m_{pi} . This indicator is equal to the ratio of water flow rate through the first q_1 and the last nozzle q_{last} ; it is recommended for cooling towers within $m_{pi}=0.9...0.95$. The indicator m_{PT} depends on the number of openings within a distributing pipeline K_ω , which is the ratio of the total area of all openings, arranged for spraying devices along DP, to the DP cross-sectional area ($K_\omega \leq 0.20...0.25$). According to [3], the flow of water through the last spraying devices along DP is defined from formula $q_m = q_r m_{pi}/100$, which does not account for the water head before them. Therefore, procedure [3] is acceptable only at the same or specific water heads lengthwise DP. This condition limits water flow rate along DP, or its length. In this case, it is possible to ensure the uniformity of spraying in another way – for example, by the higher position of spraying devices.

There are examples of TPP constructed with turbines' condensers that are cooled by air [4]. Such TPP have neither water-cooling systems, nor WDP. However, such energy units have lower efficiency and are built in regions with a limited supply of water.

The technology WSAC combines a tubular heat exchanger of the condenser and a wet cooling tower in a shared building [5]. The wet air-cooler of used steam ensures the lower temperature of its condensate and the wetting water at the outlet from the cooling tower. However, the authors did

not describe the structure and features of the humidification system for a cooling tower's heat exchanger.

Paper [6] advanced theoretical bases of the kinetics and hydrodynamics of a flow of liquid along a perforated (WDP) pipe, in terms of changes in water pressure. There, the analytical model includes the components of pressure, gravity force, friction force, and rate pulse. However, the study considered the water-discharge openings with a diameter of about 1.0 mm, which cannot be used for cooling systems with WDP.

Study [7] investigated the influence of shape of the output openings arranged in the walls of a perforated pipeline on the characteristics of outlet jets. The authors studied the impact of thickness t of the wall of a rectangular distributing pipeline on the non-uniformity of water distribution along the way. Increasing the thickness of a WDP wall from 2 to 10 mm decreased the uneven distribution of water. Decreasing the overall area of WDP openings decreased the uneven distribution of water. A flow rate coefficient μ decreased within 0.66 to 0.68 at a discharge of water from the explored openings. The reported results are related only to the discharge of water through the openings in the pipe and are not applicable to nozzles.

Paper [8] studied the impact of a relative change in the diameter of a conical perforated WDP and the flow rate of water fed to it on a decrease in the non-uniform distribution of water through openings in the walls of the pipeline. It was discovered that the uneven distribution of water from a conic WDP is less than that from a cylindrical WDP. The lowest non-uniformity of water distribution was achieved when the inlet diameter of the conical DP twice exceeded the end diameter. The results reported in [8] are of interest, but such structures are difficult to manufacture and are not used in the cooling systems at TPP.

A procedure for calculating pressure WDP [9] was devised while solving a differential equation of fluid motion with a variable flow rate. The procedure takes into consideration all geometric parameters of WDP and was tested experimentally for WDP at jet outlet angles $\beta=90^\circ$ [10]. However, the application of procedure [9] additionally requires experimental values for the flow rate coefficient μ of spraying devices.

The above literary sources lack scientific research or recommendations regarding the mutual influence of hydraulic characteristics of WDP and their spraying devices. Such a reciprocal influence manifests itself by the dependence of throughput capacity of a spraying device on the head and area at the beginning of WDP. Therefore, over certain ranges in the magnitudes of head, diameters, and water flow rate along WDP, the spraying devices fail to ensure the specified hydraulic characteristics. The available literary sources lack publications on the hydraulics of nozzles for a jet steam condenser. This allows us to assume that the chosen topic addresses the unsolved scientific and technical task.

3. The aim and objectives of the study

The aim of this work is to investigate the range of mutual influence of hydraulic characteristics of water distributing pipelines (WDP) and their spraying devices using an example of the cooling system in a heat transfer equipment at TPP. It is expected that research results could be used in the practice of designing WDP of different systems.

To accomplish the aim, the following tasks have been set:

- to define the actual hydraulic characteristics of standard prefabricated nozzles for a mixing condenser;
- to determine the boundary hydraulic characteristics of WDP that ensure the design parameters for spraying devices;
- based on the obtained characteristics for a dependence of water flow rate Q on the head of nozzles, predict this dependence for the conditions of vacuum at the section of a condenser.

4. Materials and a procedure for a hydraulic study of nozzles

4. 1. Experimental equipment

Hydraulic characteristics for spraying devices are provided by a manufacturing enterprise or their designers as the dependence of water flow rate Q on head H before a spraying device. This characteristic is generally acquired for a single nozzle at special benches. We have investigated the actual hydraulic characteristics of spraying devices $2d=13$ mm and $2d=15$ mm (Fig. 1) for spraying cooling water in a condenser of mixing type.

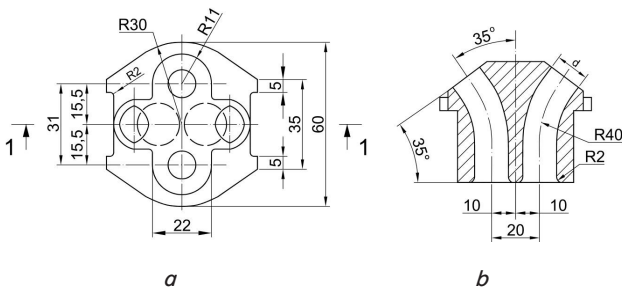

Fig. 1. Design of nozzles for a steam condenser of mixing type: *a* – top view; *b* – cross-section along 1-1

Studying the characteristic $Q=f(H)$ for standard nozzles arranged at the end of DP (Fig. 2) at the initial stage yielded almost the same values for water flow rate. This factor can be explained by that the flow rate of water, which enters the examined DP 5 (Fig. 2) and then proceeds to spray nozzle 2, is strongly influenced by a diameter of DP and the head of water where it joins pressure pipeline 1.

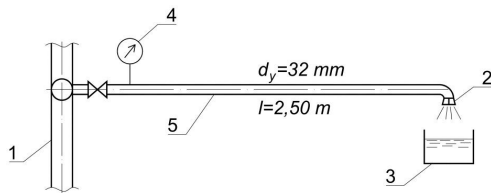

Fig. 2. Schematic of preliminary study into the characteristics $Q=f(H)$ of nozzles, arranged on a short pipe with a diameter of 32 mm: 1 – pressure pipeline; 2 – nozzle; 3 – measuring container; 4 – pressure gauge; 5 – examined section of DP

By analyzing the results of research in line with a circuit from Fig. 2, we obtain a characteristic of the pipeline, rather than the spraying device. In this case, the diameters of the nozzles' openings did not significantly impact the flow rate of water in them at the same heads.

The subsequent study was performed at a laboratory bench (Fig. 3), which eliminates the influence of the hydraulics of an underwater pipeline on the throughput capacity of nozzles.

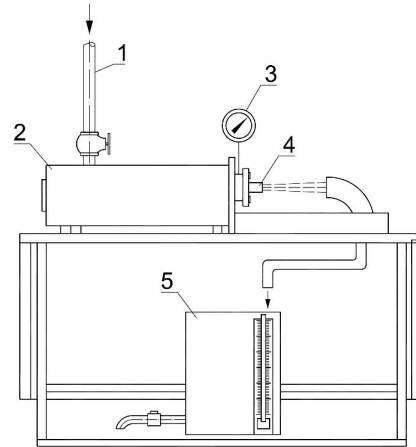

Fig. 3. Schematic of a laboratory bench for the hydraulic study of nozzle: 1 – water supply; 2 – pressure tank; 3 – pressure gauge; 4 – nozzle; 5 – measuring tank

Water pressure before the nozzle was measured with a technical pressure gauge of accuracy class 0.6. The flow rate of water in nozzles was determined by a volumetric technique based on the time of its discharge to the measuring tank.

4. 2. Procedure for studying the hydraulic characteristics of spraying nozzles

The hydraulics of water discharge through a nozzle are considered to be the outflow of a liquid through an outer cylindrical attachment. When entering a nozzle, a jet of water is compressed, and then expands, thereby filling the entire cross-section of the nozzle's openings ω_f . Thus, the jet compression coefficient at the outlet from a nozzle $\epsilon=1$; the flow rate coefficient equals the speed factor $\mu=\phi$.

Velocity V_2 of water discharge is directly proportional to its head H_0 before the nozzle:

$$V_2 = \frac{1}{\sqrt{1+\zeta_f}} \sqrt{2gH_0} = \phi \sqrt{2gH_0}, \tag{1}$$

where

$$\phi = \frac{1}{\sqrt{1+\zeta_f}}$$

is the velocity coefficient when discharged through nozzles; ζ_f is the total resistance coefficient of a nozzle. For large Reynolds numbers, $\mu=\phi$.

The magnitude of water head H_0 (m H₂O), which ensures velocity V_2 in a nozzle is determined from formula

$$H_0 = \left(z + \frac{p_0}{\gamma} \right) = \frac{\alpha V_2^2}{2g} + h_{1-2}, \tag{2}$$

where p_0 is the manometric pressure at the surface of liquid, kgf/m²; γ is the specific weight of water, kg/m³; z is the distance from a nozzle's opening to a pressure gauge, m; V_2 is the speed of water discharge, m/s; α is the coefficient of kinetic

energy; $h_{1,2}$ are the losses of head (m H₂O), which consist of head losses for water that enters the nozzle, for the expansion of the compressed jet inside the nozzle, and head losses along its length. Losses of water head lengthwise a nozzle are insignificant, so they are not taken into consideration.

The estimated water flow rate in a nozzle is determined from formula

$$Q_r = \mu \omega_f \sqrt{2gH_0}. \tag{3}$$

The coefficient of water flow rate in a nozzle μ is equal to the ratio of the actual (measured) water flow rate Q_f to the estimated flow rate Q_r defined without regard to the flow rate coefficient, that is, $\mu = Q_f / Q_r$.

5. Results of the hydraulic study of nozzles

5. 1. The hydraulics of a water flow along a short pipeline with a nozzle at the end

We shall verify the results from a laboratory study using the theoretical calculations of dependence $H=f(Q, d_f)$. Theoretically, based on equation [5], for a short DP, we apply appropriate formulae for the calculation of a pipeline with a nozzle at the end. Thus, the flow rate of water at the beginning and at the end of the pipeline is equal, that is, $Q_1=Q_2$; or $V_1\omega_1=V_2\omega_2$. Therefore, for a pipeline with the inlet opening of an area of $\omega_1=\omega_{pi}$, water flow rate depends on the inlet velocity V_1 , which is equal to the velocity of water along a pipeline V_{pi} . The latter is calculated from formula

$$V_1 = \varphi \sqrt{2g(H_1 - \sum h_w)} = \varphi \sqrt{2g \left(H_1 - \lambda \frac{l}{d} \frac{V_1^2}{2g} - \zeta_f \frac{V_2^2}{2g} \right)}, \tag{4}$$

where $\sum h_w$ is the sum of water head losses along the length and in a nozzle.

For nozzles with different diameters of openings (13 mm and 15 mm), according to formula (4), the values for V_1 are in a power dependence on the loss of head in the nozzle, that is, components $\zeta_f V_2^2 / 2g$. Results of numerical modeling of mutual influence of hydraulic characteristics of WDP and nozzles are given in Table 1.

Table 1

Estimation of influence of the nozzles' diameter on the hydraulic characteristic of a short pipeline of 32 mm

No. of entry	Q_r , dm ³ /s	Nozzle diameter, and opening area	V_2 , m/s	ζ_f	$\zeta_f V_2^2 / 2g$, m H ₂ O	Difference ΔH_p , m H ₂ O
1	1.10	2d=1.3 cm, 2,654 cm ²	4.1	0.20	0.17	0.08
2	1.10	2d=1.5 cm, 3,532 cm ²	3.1	0.15	0.09	

Note: numeric values for ζ_f were determined from the reference literature [11]

Therefore, a change in the loss of head along WDP ΔH_p by 8.0 cm does not lead to a substantial change in the water flow rate along the pipeline. For example, at water heads of 1.0 m before the nozzles with a diameter of 13 mm and 15 mm, the water flow rates are, respectively, 4.0 m³/h and 5.33 m³/h (according to specifications), that is, they differ by 32 %.

We shall define the boundary conditions when water flow rate along DP depends on the nozzle throughput capacity. The original axiom is the inequality when the throughput of nozzles along DP is lower than the throughput capacity of DP, at a specific head at the start of DP, that is

$$(\sum Q_f \cdot n) \leq Q_{pi} \text{ or } \sum (V_f \omega_f) \leq V_{pi} \omega_{pi}.$$

Typically, the total area of nozzles' openings must not exceed a value of 0.9...0.8 of a pipeline's cross-sectional area.

Then the main parameter that defines a WDP transition to the mode that ensures nozzles' performance according to specifications would be the head of water at the inlet to WDP at appropriate values $\sum \omega_f$ and ω_{pi} . Under boundary conditions, one can consider $\sum \omega_f \approx \omega_{pi}$. The minimum head $H_{min pi}$ at the beginning of WDP for letting the estimated flow rate of water through nozzle Q_f is determined from formula

$$H_{min pi} \geq \frac{Q_f^2 n}{\omega_{pi}^2 \mu^2 2g}. \tag{5}$$

The estimated value for Q_f in formula (5) shall be accepted according to the specifications to the nozzle. In this case, there will be an appropriate specified radius of spraying water by the nozzle, which affects the distance between the adjacent nozzles in WDP. Thus, the refined formula (5) takes into consideration working parameters $Q=f(H)$ for a spraying device.

5. 2. Determining the actual hydraulic characteristic for a nozzle

The actual hydraulic characteristic of nozzle $Q=f(H)$ was determined by volumetric measurement at the equipment shown in Fig. 3. The results are given in Table 2.

Table 2

Hydraulic characteristic of nozzle $Q=f(H)$

2d=13 mm			μ	2d=15 mm			μ
No. of entry	H, m H ₂ O	Q, m ³ /h		No. of entry	H, m H ₂ O	Q, m ³ /h	
1	0.5	2.7	0.90	1	0.15	2.0	0.92
2	1.0	4.0	0.95	2	0.3	3.13	0.92
3	1.5	4.5	0.87	3	0.5	3.43	0.86
4	2.0	5.14	0.86	4	0.7	4.0	0.85
5	2.5	5.76	0.86	5	1.0	5.33	0.95
6	3.2	6.55	0.87	6	1.3	6.0	0.93
				7	1.48	6.47	0.945

The actual water flow rate of nozzle 2d=13 mm is slightly higher at heads to 1.5 m than that given in the specifications, and smaller at heads above 2.5 m H₂O (Fig. 4). The throughput of nozzle 2d=15 mm at heads larger than 1.2 m is higher than that given in the specifications.

The value for a flow rate coefficient varied from 0.945 to 0.860. We accepted the average value for a flow rate coefficient $\mu=0.90$. In the course of our study it was found that the spraying of water jets from nozzles at low heads is absent, and is insignificant at larger ones.

This might affect the rise in pressure in the steam space of a condenser and thus slightly reduce the capacity of a turbo generator.

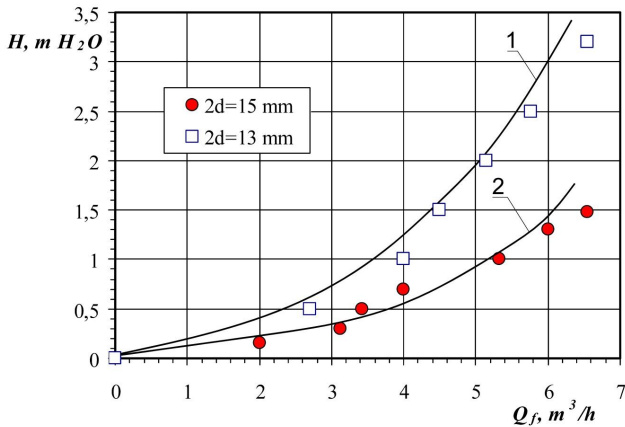

Fig. 4. Experimental and specified hydraulic characteristics for nozzles of a condenser (under atmospheric conditions): 1 – the specified characteristic of nozzle $2d=13$ mm; 2 – the specified characteristics of nozzle $2d=15$ mm

5. 3. Hydraulic characteristic for nozzles under conditions of vacuum in the condenser

Under actual operation of nozzles in a condenser, water is discharged into a vacuum of the steam space (Fig. 5). Therefore, we predicted the water flow rate in nozzles under operating conditions. The estimated magnitudes for full head H_0 for Q_f in formula (3) were determined based on the following factors:

- the estimated atmospheric pressure in the area where TPP is located is 620 mm Hg, or $620 \times 133 = 82,640$ Pa;
- the vacuum in a pipeline that supplies cooling water at the inlet to the condenser at the level of middle series of nozzles is $P = -0.25$ kgf/cm², or $0.2 \times 98,066.5 = 19,613$ Pa;
- the absolute pressure in a water supply pipe is $82,640 - 19,613 = 62,847$ Pa;
- the vacuum pressure in the steam space of a capacitor is $P_{vac} = 0.10$ kgf/cm², or 9,807 Pa;
- the estimated temperature of cooling water is 28 °C, the volumetric weight is 996 kg/m³.

Thus, the estimated average water pressure drop on a spraying nozzle in the condenser is $62,847 - 9,807 = 53,040$ Pa, or $H_0 = 5.43$ m H₂O. Note that the specified parameter also depends on the direction of water discharge from a nozzle – up or down.

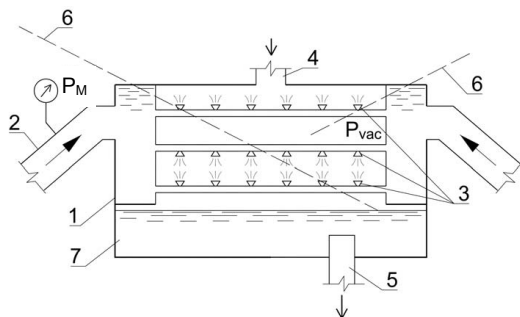

Fig. 5. Diagram of the hydraulic calculation of nozzles in a condenser of mixing type: 1 – steam condenser of a turbo assembly; 2 – pipeline that supplies cooling water; 3 – nozzles; 4 – supply of steam from a turbine; 5 – discharge of hot water; 6 – piezometric line of water head in the underwater circus water pipe; 7 – condensate; P_M – pressure of cooling water at inlet, P_{vac} – pressure of steam in a condenser

The pressure in a cooling water pipeline at the section of its connection and arrangement of nozzles within the steam condenser is vacuumetric (Fig. 6). This is the result of:

- the siphon action of water discharge from spraying devices;
- vacuum in the steam space of a condenser;
- the level of water in a condenser.

In the steam condenser itself, the vacuum is still lower than that of the intake and WDP with nozzles. Water is discharged from a nozzle under the influence of the difference in vacuum pressures. Theoretical maximum flow rate of water in a nozzle can be defined from formula

$$Q_{max f} = \mu \omega_f \sqrt{2g\Delta P}. \tag{6}$$

The predicted water flow rate in a nozzle under operational conditions of pressure of the cooling water and steam in a condenser is determined from formula (6) and is given in Table 3.

Table 3

Predicted water flow rate in nozzles under condition of vacuum in a condenser

Nozzle type	Pressure drop, ΔP m H ₂ O	μ	Water flow rate Q_f , m ³ /h
$2d=13$ mm, $\omega=0.02654$ dm ²	5.43	0.85	8.36
$2d=15$ mm, $\omega=0.03532$ dm ²	5.43	0.85	11.13

As a result of the higher head under conditions of the condenser, the throughput capacity of nozzles (quantity n) will be higher than the supply of water in a water line. However, this possibility will be limited by the magnitude of supply of cooling water Q_{pi} by pumps in the system. That is, the total flow rate of water nozzles in a condenser will be equal to $Q_{f fakt} n \leq Q_{max f} n = Q_{pi}$.

The magnitude for the latter is determined based on the working point of pumps at the hydraulic characteristic of a cooling system. Taking into consideration the difference between the maximally possible and actual water flow rate, the number of the installed nozzles may differ. Thus, we define the operationally justified water flow rate in a nozzle $Q_{f exp} = f(R, W_{fo}, \Delta P)$ under conditions of a steam condenser taking the following into consideration: its spraying radius R and the volume of fountain W_{fo} at appropriate pressure ΔP and water supply. We determine the required number of spraying devices in WDP at the condenser of a turbine assembly

$$n = Q_{pi} / Q_{f exp}. \tag{7}$$

Under actual operating conditions, the hydraulic characteristics of WDP spraying devices in coolers are affected by:

- the head of water at the beginning of WDP, the height of arranging spraying devices along it, and the technological scheme of water supply;
- the hydraulic characteristic of distributing pipelines, their diameters relative to the main pipeline or a riser.

At the stage of the commercial launch of a power unit, the TPP management team was tasked to increase the flow of water to the condenser to improve energy performance. It was proposed to enlarge (drill) the openings of nozzles. Our analysis reveals the impossibility to increase water supply to

the turbine condenser in this way because the decisive condition is the magnitude of water supply in the system circulating pumps – circulating cooling water lines – cooling tower – condenser. However, it is possible to increase the flow of water from the cooling tower to the turbine's condenser by reducing the resistance at the section of hydraulic turbine by opening its guiding device or throttles (Fig. 6).

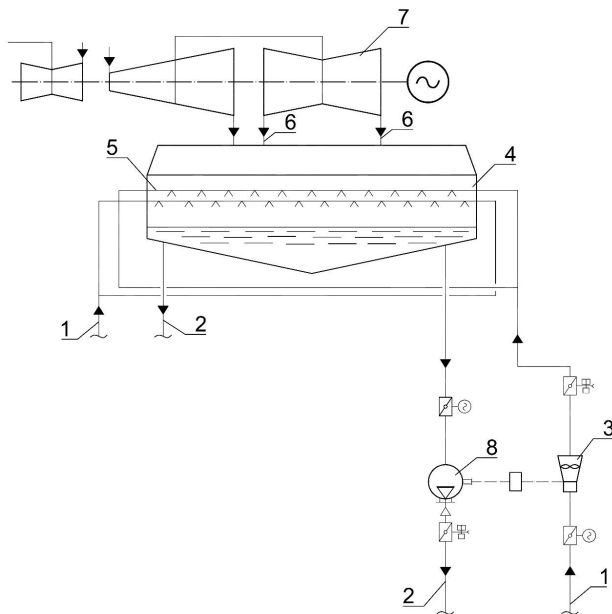

Fig. 6. Schematic of equipment for a circulating system at the section of a pumping station: 1 – supply of circulating cooled water; 2 – water discharge to a cooling tower; 3 – a hydraulic turbine combined with a circulating pump; 4 – steam condenser of mixing type; 5 – WDP with nozzles; 6 – supply of steam from a turbine to a condenser; 7 – turbine of energy unit; 8 – circulating pump

However, this will lead to a change in the level of water in the cooling tower and to a further increase in the feed of circulating pump and a loss of head in the circulating system of technical water. Because the cooling system is closed, the increase in water supply will actually increase its volumetric velocity (m^3/s). As a result, there will occur a decrease in the time the circulating water is within the radiator cooling tower and in the degree of its cooling. This leads to a rise in temperature and pressure in the steam space of turbine's condenser and certain reduction in the turbo assembly capacity.

6. Discussion of results of studying the mutual influence of hydraulic characteristics of nozzles and a water distributing pipeline

Taking into consideration the factor of hydraulic mutual influence of nozzles and their WDP improves the design of water-cooling systems in tower coolers, spraying pools, etc.

The diameters of main and side pipelines will be substantiated – this is the practical significance of our research results. In addition to the above WDP at cooling systems as part of TPP, the results of the current study could be applied:

- to calculate the systems of hydraulic removal of rock when drilling wells;
- when designing spraying equipment, etc.

The result of this study established that the hydraulic reciprocal influence of WDP and nozzles that are arranged along it occurs at the appropriate ratio of their openings' areas to the heads of water. The actual characteristics for water flow rate in nozzles would not meet factory settings in the case when actual water head H before the nozzle is lower than the minimally acceptable according to formula (9) (for the specified and estimated values for Q_f). This factor is important to undertake a research, as well to improve hydraulic calculations of WDP.

The study was confined to water heads to 0.05 MPa, which are characteristic of the operation of nozzles in the systems of cooling equipment at TPP. Therefore, the obtained theoretical dependences do not apply to similar WDP with heads above 0.1 MPa.

At this stage, our work is only partially completed. In the future, it is advisable to conduct a comprehensive study into the entire system, specifically: a circulating pump station, a cooling tower condenser with WDP and nozzles. In this case, it is necessary to carry out comprehensive hydraulic and thermal studies of similar cooling system as part of TPP.

The shortcoming of the current study is that it does not cover the entire cooling system.

The results of our research have made it possible to fully resolve the issue on the influence of a WDP hydraulic characteristic on water flow rate in the nozzle, expressed by the formula of the minimum water head at the beginning of WDP.

7. Conclusions

1. The actual throughput capacity of spraying nozzles coincides with data given in the specifications in a central part of their characteristics. At the upper part of characteristic $Q=f(H)$ their throughput capacity is lower by 10–15 %. It is impossible to obtain reliable characteristics for nozzles while examining them along a short pipeline without the required ratios of their openings' areas to water heads.

2. We have constructed a formula for determining the minimum head at the beginning of WDP, which ensures that a nozzle discharges water at the estimated flow rate. Its magnitude depends on a diameter of WDP, the factory-defined value for water flow rate in a nozzle, and their quantity.

3. Under conditions of vacuum in the steam condenser of a turbine, the water pressure drop in nozzles is higher. Therefore, their throughput capacity is higher. However, the overall water flow rate in nozzles will be limited by the magnitude of cooling water feed from circulating pumps in the cooling system.

References

1. Posobie po proektirovaniyu gradiren (k SNiP 2.04.02-84 „Vodosnabzhenie, Na ruzhnye seti i sooruzheniya“). Moscow: CITP Gosstroya SSSR, 1989.
2. Study of the rules-based coordinated control of a condenser pressure system / Wei Z., Xin-qian B., Guo-qing X. et. al. // Journal of Engineering for Thermal Energy and Power. 2009. Vol. 24, Issue 2. P. 188–191.

3. Vodoraspredeitel'nye sistemy bashennyh gradiren / Fedyayev V. L., Morenko I. V., Molov V. I., Gaynullin R. F. // Shkola-seminar molodyh uchenykh i specialistov akademika RAN V. E. Alemasova «Problemy teplomasoobmena i gidrodinamiki v energomashinostroenii»: Materialy dokladov. Kazan', 2008. P. 170–173.
4. Influences of Cooling Air Face Velocity and Temperature on Dynamic Characteristics of Direct Air-cooled System / Yufeng G., Hua Q., Daren Y., Xiaomin Z. // CSEE Journal. 2008. Vol. 29. P. 22–27.
5. Husick C. California's Otay Mesa selects Niagara Blower WSAC to keep its cool // Modern Power Systems. 2008. Vol. 28, Issue 6. P. 45.
6. Analytical equation for outflow along the flow in a perforated fluid distribution pipe / Liu H., Zong Q., Lv H., Jin J. // PLOS ONE. 2017. Vol. 12, Issue 10. P. e0185842. doi: <https://doi.org/10.1371/journal.pone.0185842>
7. Lee S., Moon N., Lee J. A study on the exit flow characteristics determined by the orifice configuration of multi-perforated tubes // Journal of Mechanical Science and Technology. 2012. Vol. 26, Issue 9. P. 2751–2758. doi: <https://doi.org/10.1007/s12206-012-0721-z>
8. Modeling the Uniformity of Manifold with Various Configurations / Hassan J. M., Mohamed T. A., Mohammed W. S., Alawee W. H. // Journal of Fluids. 2014. Vol. 2014. P. 1–8. doi: <https://doi.org/10.1155/2014/325259>
9. Cherniuk V. V. Metod rozrakhunku napirnykh rozpodilchykh truboprovodiv // Prykladna hidromekhanika. 2008. Issue 3. P. 65–76.
10. Chernyuk V., Orel V. Experimental Verification of a New Method of Calculation for Pressure Distributive Pipelines // Zeszyty Naukowy Politechniki Rzeszowskiej. 2009. Issue 266. P. 27–34.
11. Idel'chik I. E. Spravochnik po gidravlicheskim soprotivleniyam / M. O. Shteynberg (Ed.). 3-e izd., pererab. i dop. Moscow: Mashinostroenie, 1992. 672 p.

З метою інтенсифікації теплообмінних процесів в елементах енергетичного обладнання при мінімальних енерговитратах була розроблена концепція часткового структурування теплообмінної поверхні. Для визначення енергоефективності часткового структурування теплообмінної поверхні при перехідних числах Рейнольдса розглянуто поверхню у вигляді витого гофрування. Часткове вите гофрування за рахунок зміни структури течії дозволяє отримати збільшення конвективної складової теплообміну при помірному зростанні гідравлічних втрат за перехідних режимів течії. На підставі прямого чисельного моделювання формування тривимірної нестационарної структури течії на початковій ділянці труби з витотою гофрованою вставкою при ударному вході і перехідному числі Рейнольдса показано взаємозв'язок збуреної структури неізотермічної течії із значенням інтенсивності теплообміну на поверхні труби. Показано вплив величини температурного напору на швидкість зростання збурень прилежового шару в трубі, в межах якого формуються низькочастотні коливальні процеси потоку, що призводять до збільшення конвективного теплообміну. Досліджено характер течії і зміни гідродинамічних і теплових параметрів всередині гофрованої вставки. Визначено ступінь впливу витого гофрованої вставки, що не загромождає прохідний переріз труби, на розвиток власних коливань в трубі. Досліджено вплив кута нахилу витого гофрування до осі труби на теплові та гідродинамічні процеси в ній. Отримана інтенсифікація теплообміну (до 20 %) при супутньому зростанні гідравлічних втрат (до 7,5 %) корелює з експериментальними результатами інших авторів при подібних параметрах гофрування в даному діапазоні чисел Рейнольдса

Ключові слова: часткове гофрування, вите гофрування, теплообмін в трубі, інтенсифікація теплообміну, гідравлічний опір

UDC 532.542

DOI: 10.15587/1729-4061.2019.165852

INFLUENCE OF THE FLOW STRUCTURE FORMATION ON HEAT TRANSFER PROCESSES IN TUBES WITH SPIRAL CORRUGATED INSERTS

O. Baskova

Engineer of 1 category*

E-mail: BaskAleksandra@gmail.com

G. Voropaiev

Doctor of Physical and Mathematical Sciences,

Professor, Head of Department*

E-mail: voropaiev.gena@gmail.com

*Department of Hydrobionics and

Boundary Layer Control

Institute of Hydromechanics National Academy of

Sciences of Ukraine

Zhelyabova str., 8/4, Kyiv, Ukraine, 03680

1. Introduction

Energy efficiency of heat transfer equipment with fuel shortage is a key issue for the power industry. To increase

the rate of heat transfer processes, there are several methods, centered on changing the flow structure by acting on it from the outside or changing the shape of the heat transfer surface. The latter method is less power-consuming, but its