

UDC 624.012.44/45

DOI: 10.15587/1729-4061.2019.174476

Дослідження було присвячено вивченню міцності та деформативності вузла з'єднання збірних плит і монолітних ригелів плоского збірно-монолітного перекриття, ґрунтованого на роботі шпонок. Чинні нормативні документи по проектуванню залізобетонних конструкцій не враховують розрахунок вузлів з'єднання збірно-монолітних конструкцій плоских перекриттів з урахуванням шпонок.

Розроблена методика експериментальних досліджень, що враховує особливості роботи збірної плити у складі перекриття. Виявлено, що при зміні виду опор змінюються параметри напружено-деформованого стану зразків збірно-монолітного перекриття: відносні деформації бетону, деформації зразків, а також міцність.

Випробування зразків збірно-монолітного перекриття показали надійну роботу, як стику, так і нормального перетину плити. Визначено, що вузол з'єднання збірних багатопустотних плит з монолітним ригелем за допомогою шпонок має 1,42 кратний запас міцності.

Представлені результати натурних випробувань фрагмента каркасу будівлі на вплив вертикальних навантажень. Показано, що розвиток деформацій основних несучих елементів перекриття відбувався практично по лінійній залежності і склали 18,55 мм (для центральної збірної плити осередку перекриття) і 14,64 мм (для несучого ригеля). Дані деформації більш ніж в 2 рази менше допустимого значення вертикальних деформацій (прогину) для цих елементів, рівного 40 мм.

За результатами натурних випробувань були зроблені висновки, що збірні і монолітні елементи диска перекриття працюють як цілісна конструкція. При випробуваннях взаємних зміщень торців збірних плит відносно несучих ригелів виявлено не було.

Вдосконалена методика розрахунку міцності вузла з'єднання. Зміна міцності зразків плоского збірно-монолітного перекриття враховується введенням відповідного коефіцієнту умов роботи поперечної арматури, рівного 0,8

**Ключові слова:** збірно-монолітне перекриття, плоске перекриття, шпоночне з'єднання, міцність конструкції перекриття

# INVESTIGATING THE STRENGTH AND DEFORMABILITY OF THE NODE THAT CONNECTS PRECAST SLABS AND MONOLITHIC JOISTS IN A FLAT PRECAST-MONOLITHIC FLOORING SLAB

**O. Butska**  
PhD\*

E-mail: helenochka@i.ua

**T. Nikiforova**

Doctor of Technical Sciences, Associate Professor\*

E-mail: nikiforova\_t@pgasa.dp.ua

**M. Makhinko**  
PhD\*

E-mail: kolia2785@gmail.com

**S. Shekhorkina**  
PhD\*

E-mail: svetlana.svt.28@gmail.com

\*Department of Reinforced Concrete and Masonry Structures  
Prydniprovsk State Academy of Civil Engineering and Architecture  
Chernyshevskoho str., 24a, Dnipro, Ukraine, 49600

Received date 02.05.2019

Accepted date 12.07.2019

Published date 12.08.2019

Copyright © 2019, O. Butska, T. Nikiforova, M. Makhinko, S. Shekhorkina

This is an open access article under the CC BY license

(<http://creativecommons.org/licenses/by/4.0>)

## 1. Introduction

The period of up to 1990s was dominated by the trend implying the construction of residential, public, and industrial facilities using prefabricated structures. That provided the possibility for all-season industrial construction. However, it led to a significant rise in the cost of buildings as a result of typification, unification, and standardization, as well as to increasing transportation costs for delivery of raw materials to factories, and finished products – to consumer.

In addition, the shortcomings of such facilities included monotonous architectural design, the impossibility to transform spatial-planning solutions in the process of operation.

The stricter energy efficiency requirements to buildings necessitated the separation of bearing and enclosing func-

tions in the designs of facilities. Under these conditions, the most rational is a frame structural scheme of buildings in which the frame is responsible for bearing functions and the outer walls – for protecting and thermal-insulating functions.

Currently, monolithic framework construction is the most common. However, in addition to benefits (free selection of a planned design that does not depend on standard elements), monolithic construction has its drawbacks. The floor slabs, due to their significant weight during construction of a monolithic frame, are limited for length. A monolithic frame requires a large consumption of steel, considerable amount of expensive formwork and supporting devices. Such a frame is dependent on a construction season (in summer, the need to apply specialized devices for concrete wetting;

in winter, heating or the use of specialized cold-resistant admixtures). All this leads to higher construction costs.

It is possible to combine benefits when applying the precast monolithic systems of structures with a flat flooring slab that largely employ individual industrially-prefabricated articles and monolithic structures. Of the total cost of facilities, flooring slabs account for up to 25 %. A precast monolithic flooring slab that is composed of precast hollow-body slabs and monolithic flooring joists has a lighter structure in comparison with solid concrete, which reduces loading on the foundation by up to 30 %.

Thus, it is a relevant task to devise a structural solution for a flat precast monolithic flooring slab, to reveal patterns in the change of parameters of the stressed-strained state (strength, relative deformations, deformations of elements), as well as to construct methods for strength calculation.

---

## 2. Literature review and problem statement

---

Flooring slabs are the basic structural element of building structures as they account for up to 60 % of the total volume of reinforced concrete structures in a building [1]. This means that it is an important task to determine the optimal parameters for the structure of a flooring slab, which must be considered when designing buildings.

In terms of fabrication, flooring slabs are divided into precast, monolithic, and precast-monolithic.

The structural systems of high-rise buildings that are constructed using precast reinforced concrete share one common flaw related to welded joints between the reinforced concrete elements that lead, during construction of a building, to considerable energy costs for welding operations, as well as the higher cost of corrosion protection. In high-rise buildings, a sharp increase in the value for horizontal loads and the emergence of a dynamic component in their values result in the problems associated with reliability and durability of such buildings, which significantly depend on the durability and endurance of welded joints.

In recent years, monolithic reinforced concrete frameworks have been increasingly used in the construction of high-rise residential and public buildings as evidenced by practice of construction. High-rise buildings with a monolithic frame demonstrate high strength properties when exposed to horizontal loads. The disadvantages of monolithic reinforced concrete structures that are fabricated without being exposed to initial stress include:

- increased consumption of steel, because in this case soft (low-strength) steels are most often used;
- the need to equip with high-quality formwork and supporting devices;
- limited construction season.

Paper [2] notes that choosing any type of a flooring slab for the construction of any building is predetermined by a series of parameters, the most important of which are the following: the functional purpose of a facility, the nature of loads, estimated lifespan, slabs' dimensions, local operating conditions. The author drew a conclusion on that there had appeared technical solutions aimed at reducing the labor-intensity of operations, improving quality of a structure. The predefined properties are demonstrated by structures from precast-monolithic concrete. The precast-monolithic residential buildings and public facilities, similar to monolithic,

render expressiveness to settlement areas, and can reduce the cost of construction by 10–15 %.

Study [3] also reports findings on that the use of precast monolithic flooring slabs in civil and housing construction is economically justified. Such flooring slabs combine the positive properties of both the precast and monolithic reinforced concrete: weight reduction in a flooring slab (by using lightweight structures), forming the integrity of elements and a possibility to reduce the use of formwork. The spatial integrity of such structures, due to the monolithic nature of all prefabricated elements, greatly improves the rigidity and spatial stability of a structure, which leads to savings in a material.

In addition, main advantages of the precast monolithic technique to erect buildings include a possibility to construct at any time of year. That reduces the time of construction; in this case, the structures of a building demonstrate high quality of the applied materials [4].

It is the framed buildings from precast monolithic reinforced concrete that are gradually gaining popularity, making it possible to reduce the time of construction by 30 % and lower the cost of buildings by 15 % [5].

Reinforced concrete precast-monolithic flooring slabs are divided into beam (ribbed) and beamless (flat).

Work [6] notes that ribbed flooring slabs are mainly used at industrial and civil facilities and are almost never used in residential buildings. Parts of the beams protruding into the volume of premises are the main disadvantage of these types of structures.

The issues related to ribbed flooring slabs are partially resolved by beamless flooring slabs [7]. The specified paper notes that concrete structures may not need beams, although that would make the flooring slab more flexible at the same thickness of a slab. For beamless precast monolithic flooring slabs, a frame for the reinforced concrete is the precast elements – panels over columns and spanning panels. Such a structure is very labor-intensive and has a low rate of construction, which is confirmed by another study [8].

An option to overcome the respective shortfalls could involve the use of beamless flooring slabs with no column caps [9]. These flooring slabs have some advantages over other types of flooring slabs that imply the ease of fabrication and less consumption of materials, the least structural height, a flat and smooth ceiling, thereby making it possible to freely arrange equipment inside.

However, because of the overall small thickness of flooring slabs and the absence of column caps, the flooring slabs' deflections are relatively large. Additional deformations due to creep double the magnitude of elastic deflections [10].

Precast monolithic flat flooring slabs make it possible to construct buildings with many curvilinear surfaces. A distinctive feature of this technique is that the preparation and assembling of all the elements required for construction are carried out at the construction site. The advantage of this method is a wide range of architectural solutions for a would-be structure [11].

An important factor in modern conditions is the pace of construction that makes it possible to significantly improve the efficiency of investments in it. A building that is constructed applying a frame technology is erected much faster than under any other kind of construction.

In addition, costs in architecture and construction are brought down by rational space-planning solutions, by the proper choice of building and finishing materials, by lighter structures, by the introduction of new building techniques

(such as new ways to assemble structures, improving technical level, the use of a method for streaming input operations, etc.). Therefore, determining the most technically efficient type of a flooring slab for the framed building is a priority task of our time [12].

Below are the basic structural systems of flat precast monolithic flooring slabs for buildings that are either widely used or whose application, upon improving a structural solution, is possible for the construction of residential and public buildings, including high-rise ones.

Among the most common structural solutions for buildings that employ precast-monolithic flooring slabs in the countries of CIS, Baltic republics, and some Eastern European countries, are the following: «RADIUS»; «RADIUS NPU»; CUB 2.5; «Sochi»; the technology of precast monolithic frame construction «ZMKD».

The universal building system (RADIUSS) was described in [13]. Engineers adopted three basic structural-planning cells the size of 3.6×6.3 and 6.3×7.2 m without protruding flooring joists and columns without caps at a cross section of 20×40 cm that fit well any interior and make it possible to erect columns for different heights of floors. Smooth ceilings facilitated space-planning solutions for various types of buildings. Slabs the size of a cell simplified installation and equipment, but, due to the large weight (6.5...8.5 t), required powerful enough transportations means and crane equipment.

A flat flooring slab of the system CUB 2.5 (universal beamless structure) was first applied in the 1960s [14, 15]. The discs of a flooring slab include the precast flat top-column reinforced concrete slabs with a thickness of 16 cm and the plan size of 2,800×2,800 mm with a through hole in the middle, for mounting atop the columns designed for vertical position. The system CUB is characterized by the absence of protruding parts from the discs of a flooring slab and multi-tiered columns. However, the system «Cube-2.5», as well as its subsequent modifications, has serious drawbacks. It requires considerable metal consumption by the device for embedded parts and a high volume of responsible welding operations at a construction site.

The precast monolithic flooring slab «Sochi» [16] employs typical round hollow slabs, which are commonly fabricated at factories. Between their ends within the thickness of a slab are the reinforced concrete monolithic principal beams (flooring joists). The columns of a square, rectangular, or round cross-section must have, at the level of flooring slabs, areas without concrete or holes in the concrete to allow for the reinforcement of a monolithic flooring joist. However, the operation of a node that connects the precast slabs with a monolithic flooring at such a flooring slab has not been studied in detail. A given flat precast monolithic flooring slab «Sochi» was not widely used in the USSR.

Analysis of practices of constructing framed buildings with the use of precast monolithic reinforced concrete points to the application, in different countries, of both similar and different structural solutions for precast monolithic flooring slabs. The most common are: Saret – France, and its followers – Saret-Cheboksary; «IMC» – Yugoslavia; the Bulgarian frame «NiproITIB»; «Arkos» – Belarus BelNIIS.

The flooring slab «Saret» [17] is composed of precast slab formwork with a thickness of 60 mm with the longitudinally pre-stressed reinforcement Bp-2 with a diameter of 5 mm and a monolithic reinforced layer with a thickness of 60 mm, which is placed on top. Adhesion of the layers occurs

owing to the upper rough surface of the slab formwork. The disadvantages of the frame «Saret» is a large consumption of monolithic concrete and complex metal-intensive monolithic joints between columns and flooring joist, as well as the flooring joists that protrude downwards.

The system IMC with a preliminary stressed flat flooring slab was commonly used in construction in many countries [18]. Joint work of the industrially prefabricated elements was enabled by pulling the ropes in two directions. The system includes a minimum number of precast elements (columns, flooring slabs and side beams), whose combination does not require any embedded parts and welding operations. All elements of the framework of this system, flooring slabs, side elements, and columns, are connected to one another in the process of installation only at the expense of friction and a compaction effort. However, the system IMC has serious drawbacks. Intersections along the contact between the precast monolithic slabs and monolithic flooring joists, which host the preliminary stressed reinforcement, are not reinforced because they are not crossed by any working reinforcement. Modern regulations prohibit the use of such a structure, since destruction of the non-reinforced concrete cross-section of a bendable element (flooring slab) is a direct threat to the lives of people residing under the slab.

The need to unify construction techniques necessitates maintaining the same approach to constructing multi-storey residential buildings, public and administrative facilities – that could be achieved by using the system Arkos [19]. The system of the construction includes a precast monolithic frame with flat precast monolithic discs of flooring slabs. The flooring slabs' discs in the frame are formed by precast hollow slabs and monolithic pillars and bound flooring joists. The prefabricated hollow core slabs in the cells of flooring slabs are arranged in groups with each slab resting with its edges on supporting girders using concrete pins [20]. A given flooring slab has faults similar to those at IMC. The slabs are connected to flooring joists using the concrete pins, with no reinforcement in the cross-section, with is not acceptable.

The considered structural solutions for flat precast monolithic flooring slabs for residential and civil purposes have flaws that make their further use impossible.

Results from the analysis of existing flat precast monolithic flooring slabs reveal that the construction of buildings requires the development of a new, or improvement of already existing, structural solution for a precast monolithic flooring slab. Consequently, it is required to develop and improve research methods to monitor and calculate the new flooring slab.

All this gives grounds to assert that it is expedient to undertake a study aimed at examining the parameters for the stressed-strained state and determining the strength of a precast monolithic flooring slab. Special attention should be paid to the nodes that connect the precast and monolithic elements, which appear to be the most under-investigated and dangerous.

Based on our analysis, the following conclusions have been drawn:

1. At present, there is no any design for a flat precast monolithic reinforced concrete flooring slab that exploits hollow flooring slabs and monolithic flooring joists, which would demonstrate modern consumer properties and would be cost effective, which would fully meet acting normative documents. Of all known, the likely candidates are the flooring slab «Sochi» and the structural solution for a flooring slab in the system «Arkos», designed at BELNIIS.

2. To date, there are not enough data that would account for the joint work of the precast and monolithic reinforced concrete when using modern calculation methods and there are no experimental studies into parameters of the stressed-strained state and strength of the nodes that connect hollow precast slabs and monolithic flooring joists.

3. Existing regulations do not substantiate in detail the design process of a precast-monolithic flooring slab using a dowel node to connect a hollow slab and a monolithic flooring joist.

4. Acting standards on designing reinforced concrete structures do not contain provisions concerning the quantitative estimation of bearing capacity of the reinforced concrete dowel pin in a precast-concrete flooring slab.

### 3. The aim and objectives of the study

The aim of this study is to design a structural solution to the flat precast reinforced flooring slab, namely a node that connects precast slabs with voids and monolithic flooring joists.

To accomplish the aim, the following tasks have been set:

- to devise a procedure for investigating deformability and strength of a precast reinforced flat flooring slab by experimental methods;
- to perform experimental study of the nodes that connect precast hollow slabs and monolithic flooring joists;
- to develop methods for calculating the strength of nodes that connect precast slabs with voids and monolithic flooring joists in a precast-reinforced flat flooring slab;
- based on the results from our study, to improve the structural solution for the nodes that connect precast hollow slabs and monolithic flooring joists, as well as the flat precast monolithic flooring slab in general.

### 4. Structural solution, materials, and procedure to study the parameters for deformability and strength of a precast reinforced flat flooring slab

The structural system of a building under consideration includes a precast monolithic frame with flat discs of flooring slabs. The flooring slabs' discs in the frame are formed by the precast multi-void slabs and monolithic pillars and ligament joists.

Prefabricated multi-void slabs in the cells of flooring slabs are arranged in groups; each slab rests with its ends on supporting girders using concrete dowels (concrete that fills the voids in slabs when concreting a joist). Girders and beams are fabricated with the height equal to the thickness of a precast slab (the so-called conditional beams), shown in Fig. 1.

The most responsible, yet not sufficiently studied, is the node that connects a precast slab and a joist, which is given the most attention to in the current work. In this case, the node at which a flooring slab rests on a monolithic flooring joist can be executed using a reinforced dowel or a non-reinforced dowel.

The disk for a flooring slab can employ the following slabs:

- a) standard precast slabs, which are conventionally made within a locality using the existing old technological lines;
- b) slabs with no formwork, manufactured by a continuous technology followed by cutting them to the required length.

To assess the strength of the node that connects precast multi-void slabs and a monolithic flooring joist and to determine a possibility of their destruction, we scheduled testing the fragments of a precast monolithic flooring slab.

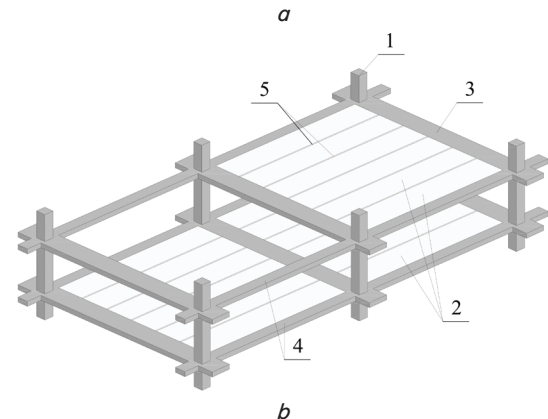

Fig. 1. Precast monolithic frame with a flat flooring slab: *a* – erecting a building; *b* – structural solution; 1 – precast or monolithic columns, 2 – precast multi-void slabs, 3 – supporting monolithic girders, 4 – ligament monolithic flooring joists, 5 – monolithic areas

The design of samples of the fragment of a flooring slab includes a multi-void industrially prefabricated slab, the series 1.141–1.63. In the current study, we employed the slab 60.12 8 A800c (At–V). The slab was made with a shortened length of 2 m, a width of 1.2 m (Fig. 2).

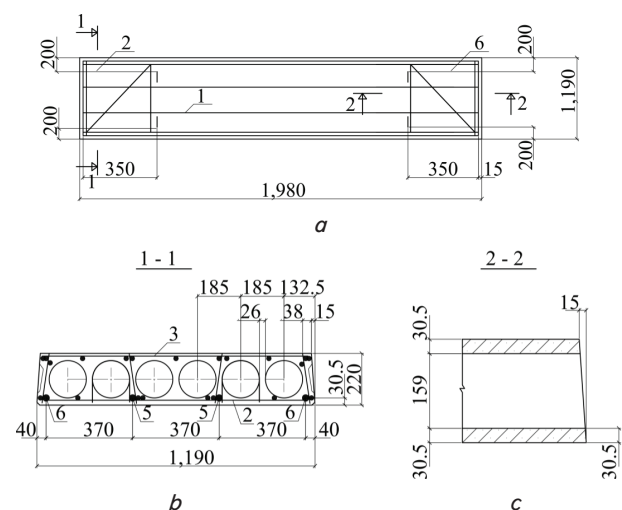

Fig. 2. Precast multi-void slab in samples of a flooring slab: *a* – formwork drawing of slab; *b* – cross-section 1–1; *c* – cross-section 2–2; 1 – frame of slab, 2 – bended grid, 3 – grid of the upper zone of the slab, 4, 5 – prestressed reinforcing rods in slab

In this case, voids from both ends of the slab are the same and host the holes with a diameter of 159 mm. The slab is reinforced with flat frames throughout the entire length. In the upper zone, the entire area of the slab's shelf is reinforced with structural reinforcing grid [21].

The area of stress transfer in the lower shelf of the slab hosted a trough-like grid with a length of 350 mm, as well as the reinforced slab reinforced with 4 rods from the pre-stressed reinforcement of class A800c (At-V).

The monolithic flooring joist was made with the height equal to the thickness of the slab of 220 mm, a width of 300 mm. The flooring joist is reinforced with flat frames combined in the spatial one. Joist (in the model) is reinforced with a structural reinforcement. To form dowels at concreting, we installed in the void prior to the onset of concreting a limiting element made from expanded polystyrene so that the depth of dowels would equal 150 mm. When fabricating a series with a reinforced concrete dowel, we fitted a flat reinforcing frame into a dowel, its height being equal to the diameter of the void (Fig. 3).

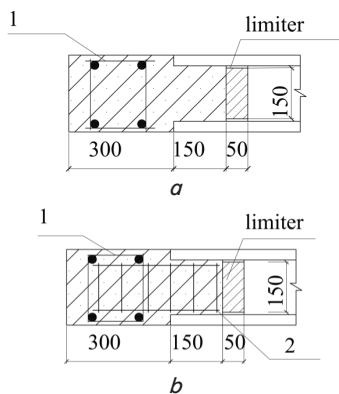

Fig. 3. Nodes at which flooring slabs rest on a flooring joist with the use of dowels: *a* – non-reinforced dowel, *b* – reinforced dowel; 1 – spatial frame of joist, 2 – flat frame of dowel

We mounted the dowel frames in the voids of slabs, through one void. Thus, the void of the slab hosted 3 frames along one facet (Fig. 4). We implemented 2 series of fragments that differ in the reinforced or non-reinforced dowel, each series included 3 slabs.

When testing samples of a flooring slab to the limit of their carrying capacity, the following types of destruction may occur: destruction of a normal cross section of the slab, cutting the dowels, a detachment of the slab's shelf or breaking of its walls.

Given a possibility for the destruction of samples of the flooring slab and the need to determine the strength of the node that connects a slab and a monolithic flooring joist, we scheduled testing the samples for bending (Fig. 5, *a*) and cutting

(Fig. 5, *b*). Load was transmitted to the slab in line with a one-point bending scheme (test for bending) or a two-point bending scheme (test for cutting).

The load was applied at stages, each of which did not exceed 10 % of the expected maximum strength of a slab at a normal cross section; for a given structure, it corresponds to a load equal to 10 kN. During tests, we measured the following: deflection in the center of a slab from two opposite sides; deformations of the concrete in the compressed and stretched zones along the joint between a precast slab and a monolithic flooring joist; width of the crack disclosure.

The purpose of testing the samples of a precast monolithic flooring slab implied:

1. Determining the load at which first normal cracks appear (if cracks appear at all), as well as their propagation (while testing a sample for bending).
2. Determining the load at which first slanted or normal cracks appear (if cracks appear at all), as well as their propagation (while testing a sample for cutting).
3. Defining the character of concrete deformation under loading at the most characteristic places of the samples' destruction; to this end, to measure these magnitudes during the experiment and to draw conclusions based on the results from tests.
4. Determining the deflection of samples of a precast monolithic flooring slab.
5. Defining the character of destruction of the flooring slab's samples.
6. Determining bearing capacity of the flooring slab's samples when tested.
7. Based on data from processing the results of the tests, to draw conclusions about operation of the nodes in a precast monolithic flooring slab.

Next, we prepared on-site testing of two adjacent cells in a precast monolithic flooring slab the size of 8 to 8 m, at an actual constructed facility for a multifunctional trade and exhibition center in our neighborhood. The purpose of testing was to assess the carrying capacity of a flat precast monolithic flooring slab exposed to the static loading with a vertical uniformly-distributed load on a flooring slab, corresponding to the estimated operational load [22].

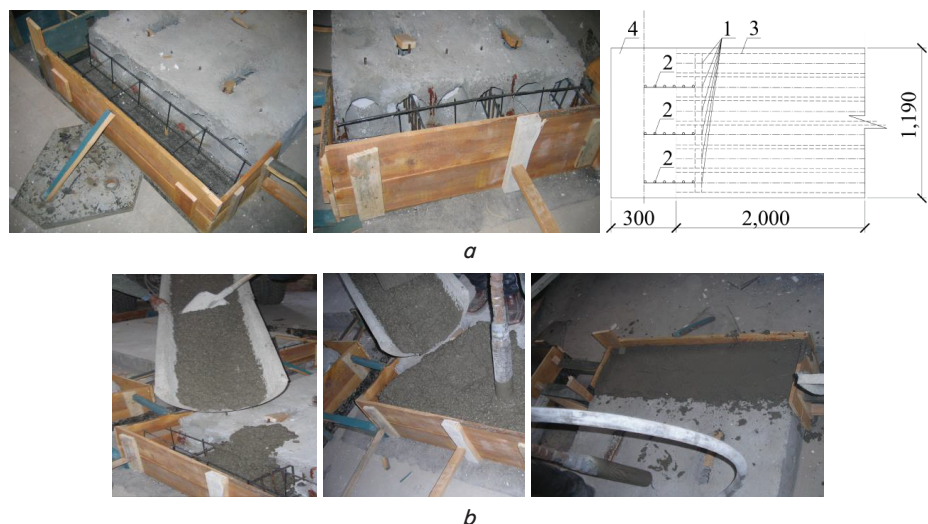

Fig. 4. Fabrication of samples of a flooring slab: *a* – preparatory work; *b* – concrete work: 1 – limiter from styrofoam, 2 – dowel's frame, 3 – precast multi-void flooring slab, 4 – monolithic flooring joist

A given fragment (Fig. 6) had the following parameters:

- along the axes of columns in one direction are the monolithic bearing girders with a width of 900 mm and a height (thickness) of 270 mm; in the opposite direction are the ligament beams with a width of 500 mm and a height (thickness) of 220 mm;

- the reinforcement of load-bearing girders and ligament beams of the flooring slabs implies the presence of spatial bound frames arranged along the axes of the facility so that along the axes there is a formed contour from conditional monolithic flooring joists and beams. The longitudinal working reinforcement of girders and beams is carried out according to the distribution of efforts, using steel A400C without a preliminary stress. In the course of the on-site experimental study of a flooring slab, we measured the deflection of the flooring slab in the center of the cells and in the center of the adjacent joist.

Testing the fragment involved a two-run scheme (Fig. 6). The test load was applied by artificial loads (foundation blocks) and sand.

The loading was applied at stages by periodically loading one, then another, cell of a building.

Maximum load was 11.7 kN/m<sup>2</sup>, which corresponds to the installed foundation blocks, shown in the diagram, and to 600 mm of sand. During aging of the flooring slab under a load for 15 minutes, we acquired readings from instruments and thoroughly examined surfaces of the flooring slab.

The purpose of the on-site testing of the fragment of a precast monolithic flooring slab included:

1. Determining the physical and mechanical properties of materials for a flooring slab under field and laboratory conditions.

2. Defining the character of concrete deformation under loading at the most characteristic places of possible destruction of the flooring slab, deriving actual values for deflections under control load during testing and drawing conclusions based on the results.

3. Determining deformability and strength of a flooring slab exposed to the vertical static loading.

4. Determining the load at which first normal or sloping cracks appear (if cracks appear at all), as well as their propagation.

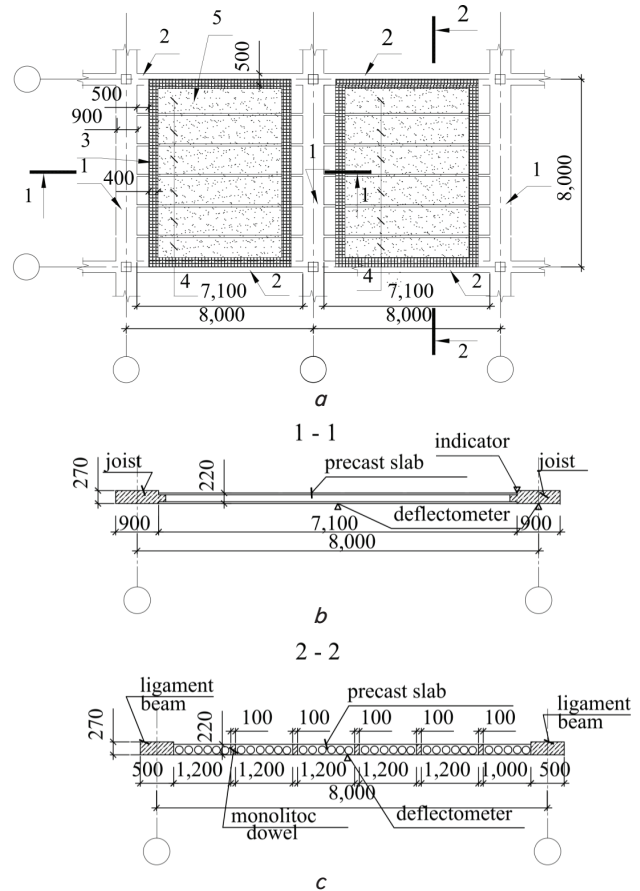

Fig. 6. Schematic of testing a precast monolithic flooring slab: *a* – diagram of the test; *b* – longitudinal cross section 1-1, *c* – transverse cross section 2-2; 1 – carrying monolithic flooring joist; 2 – ligament beam; 3 – artificial load (foundation block); 4 – precast multi-void flooring slab; 5 – sand

### 5. Results of experimental study of nodes and precast monolithic flooring slab in general

We tested sample P-1 in line with a beam scheme for bending. During tests, we measured the displacement of a slab, deformations of concrete in the compacted and stretched areas of the slab along the edge of the joint between a precast multi-void slab and a monolithic flooring joist. Upon destruction, there were no signs of breaking the adhesion and the formation of cracks at a place of junction between the precast and monolithic concrete: neither visually, nor based on the indicators' values.

The destruction occurred as a result of exhaustion of the strength of a normal cross section of a precast hollow slab under a load of 190 kN. The deflection of the slab at the point of destruction in the center of the sample amounted to 10.54 mm (Fig. 7, *a*).

After testing sample P-1 for bending, we tested the joint between the slab and the joist for the action of a transverse force (for cutting).

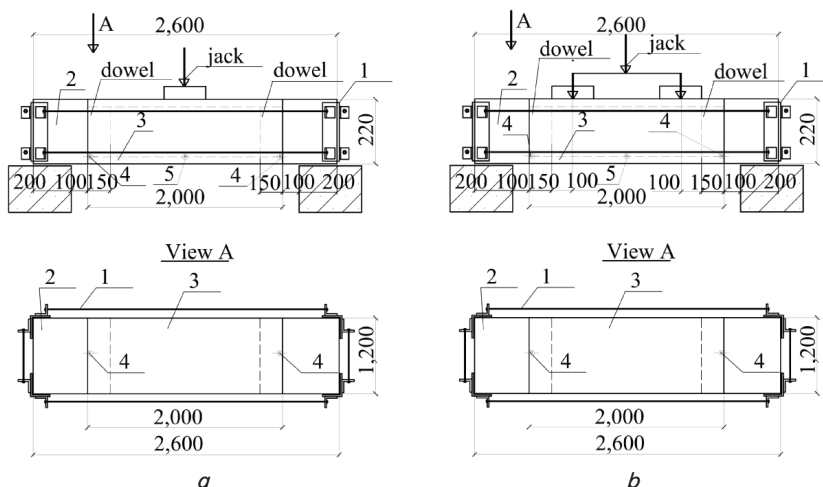

Fig. 5. Diagram of samples' tests:

*a* – for bending, *b* – for cutting; 1 – frame for receiving the spread that limits the rotation of the structure's ends, 2 – monolithic flooring joist, 3 – precast multi-void slab, 4 – a watch-type indicator; 5 – deflectometer

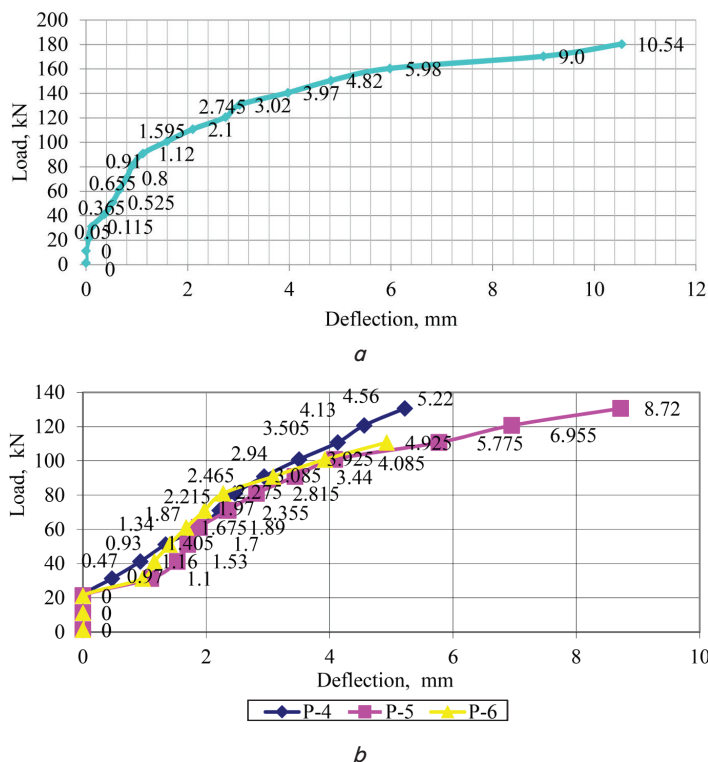

Fig. 7. Deflection along the middle of the sample: *a* – when tested for bending; *b* – when tested for cutting

The testing of samples *P-2* and *P-3* from a first series (non-reinforced dowel) and samples *P-4*, *P-5*, *P-6* from a second series (reinforced dowel) for cutting was performed according to the adopted scheme of tests (Fig. 7, *b*).

Samples *P-2* and *P-3* rested from both sides on a hinge motionless support. Samples *P-4*, *P-5*, *P-6* rested by one side on a hinge motionless support, and by the other side on the hinge moving support.

To determine the reserve of strength for the node that connects a precast slab and a monolithic flooring joist, the derived destruction efforts that emerged when testing the samples were compared to efforts that occur in structures for civil purposes (Table 1).

In this case, the maximum transverse force that occurs along a single edge of the slab is accepted to equal  $V_{max}=42.4$  kN (for buildings of commercial purposes with a flooring slab of 8 m). Results from testing and the strength margin of the node that connects a precast hollow slab and a monolithic flooring joist are summarized in Table 2.

The testing of samples of the precast monolithic flooring slab showed reliable operation of both the junction and the normal cross section of the slab.

We did not detect any displacement and cutting in a precast slab relative to a monolithic flooring joist when testing for bending (operating conditions for a flooring slab).

A node that connects the precast multi-void slabs and a monolithic

flooring joist together using dowels has a 1.42-fold strength margin (when using a given type of a flooring slab for the construction of facilities for commercial purposes with a flooring slab of 8 m). As well as a larger strength margin (in the construction of buildings with a smaller flooring slab or for residential purposes).

The on-site testing of the fragment of a flat precast monolithic flooring slab was performed at the construction site of a trade and exhibition center in region [23].

The load was applied to the disc of a flooring slab over the first tier of the frame. Vertical load was applied simultaneously to the two adjacent cells of the flooring slab. This created conditions not only for the validation of crack resistance and deformability of the flooring slab, but also enabled checking of all butt joints between monolithic flooring joists and columns and multi-void slabs.

When the disc of the flooring slab was exposed to vertical loading, the propagation of deformations in basic bearing elements of the flooring slab proceeded almost in line with a linear dependence on its magnitude. The increase in the magnitude of deflection at an increase in loading at every stage up to the reference is given in the diagram shown in Fig. 8.

The maximum values for the deflections, acquired at testing, amounted to 18.55 mm (slab) and 14.64 mm (joist), which is more than 2 times less than the permissible value for deflection for these elements, which equals 40 mm.

Table 1

The magnitude of transverse force along a single edge of the precast slab depending on the purpose of a facility and length of the flooring slab

| Purpose of a facility | The magnitude of transverse force along a single edge of the precast slab, kN |                    |                    |
|-----------------------|---|--------------------|--------------------|
|                       | flooring slab, 4 m  | flooring slab, 6 m | flooring slab, 8 m |
| residential           | 15.5  | 23.25              | 31.0               |
| office                | 16.8  | 25.2               | 33.6               |
| commercial            | 21.2  | 31.8               | 42.4               |

Table 2

Results from testing the samples of a flooring slab

| Series No. | Sample designation | Load on sample                          | Destructive load, kN | Cutting force at a node that connects a slab and a monolithic flooring joist $V_{exp}$ , kN | $V_{on}/V_{max}$ | Notes                                 |
|------------|--------------------|---|----------------------|---|------------------|---------------------------------------|
| I          | <i>P-1</i>         | in line with a one-point bending scheme | 190                  | 95  | 2.24             | destruction at normal cross section   |
|            | <i>P-2</i>         | in line with a two-point bending scheme | 250                  | 125   | 2.95             | destruction at inclined cross section |
|            | <i>P-3</i>         |   | 330                  | 165   | 3.89             |                                       |
| II         | <i>P-4</i>         | in line with a two-point bending scheme | 140                  | 70  | 1.65             | destruction at inclined cross section |
|            | <i>P-5</i>         |   | 140                  | 70  | 1.65             |                                       |
|            | <i>P-6</i>         |   | 120                  | 60  | 1.42             |                                       |

We detected no cracks at joints between the precast and monolithic elements, as well as along the length of each of the tested elements under a load equal to the complete estimated loading.

In 24 hours after the field experimental study, we performed a geodetic survey of the fragment of the flooring slab, which we tested, under a control load.

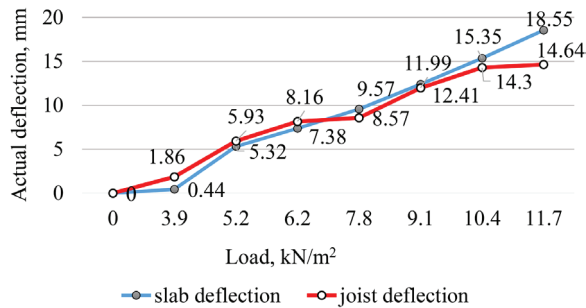

Fig. 8. Deflection of elements in a flooring slab during on-site testing

The flooring slab was conditionally split into cells the size of 1x1 m. At each point we acquired a mark from a leveling instrument. The overall pattern of the strained state of the examined slab of the flooring slab under the action of vertical experimental load equal to 11.7 kN/m<sup>2</sup>, based on the geodetic survey results, is shown in Fig. 9.

Based on the results from on-site static tests of the fragment of the built frame of a facility for the action of vertical load, we can conclude that these loads did not result in irreversible damage to the frame, as well as in its elements and joints. The deformations obtained do not exceed the permissible values regulated by acting documents. Loading matched the estimated one in terms of the first group of boundary conditions.

There was no formation of cracks, the joints remained intact.

The lack of mutual horizontal displacements of ends of the multi-void slabs relative to the side edges of monolithic flooring joists indicates that in the horizontal plane the disc of a flooring slab operates under load as a single monolithic structure.

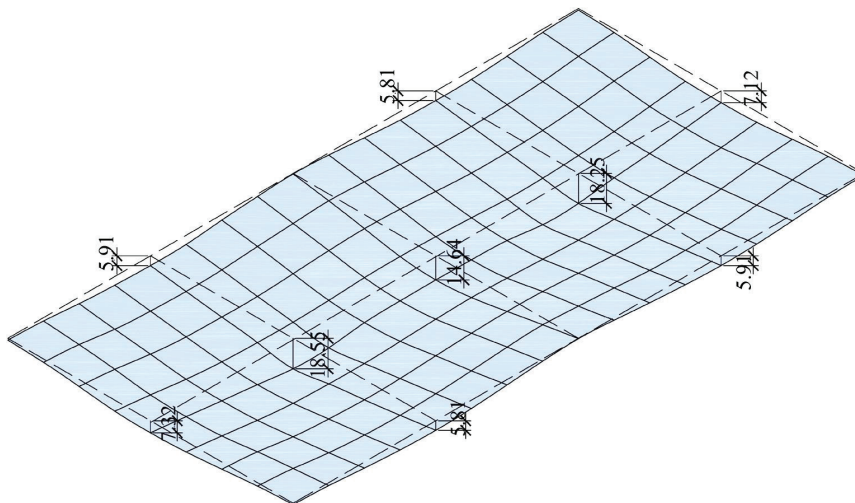

Fig. 9. General view of deformation of the fragment of a precast monolithic flooring slab after testing based on the results from geodetic survey

## 6. Results of devising methods for the calculation of a flat precast monolithic flooring slab

When testing the samples of a flooring slab for the limit of their carrying capacity, we have detected the following destructions:

- destruction along the middle of a sample - destruction of the normal cross section of the slab, such a destruction is associated with the strength of the slab itself and does not affect the joint between the slab and monolithic flooring joist;
- destruction near the sample's supports - destruction along the sloping cross section of the slab, detachment of the slab's shelf or breaking of its walls, such a destruction is associated with the node that connects a precast multi-void slab and a monolithic flooring joist. Existing rules do not contain such a calculation of strength.

No cutting of dowels was observed during testing the samples and an actual fragment of a flooring slab; however, the node that connects a hollow slab and a monolithic flooring joist is based on the operation of dowels. That is why the strength of dowels must be checked by calculation. A concrete dowel must not give rise to a crack, but it is possible that cracks appear in concrete as a result of shrinkage, so the dowels must be reinforced with a structural reinforcement.

Given the identified destruction of samples of the flooring slab, as well as to ensure strength of the node that connects a hollow slab and a monolithic flooring joist, the design of a precast-monolithic flooring slab must be checked for the following:

- 1) strength of a dowels for cutting and compression;
- 2) tensile strength of the slab's shelf or for breaking its walls [24].

Dowels work on compression at contact surfaces (compaction) and on cutting along the edges of protrusions (Fig. 10).

The condition for strength of compression at a contact surface (compaction) takes the form:

$$V \leq f_{cd} \cdot t_k \cdot l_k \cdot n_k \tag{1}$$

The condition for strength at cutting takes the form:

$$V \leq 2f_{ctd} \cdot h_k \cdot l_k \cdot n_k \tag{2}$$

where  $V$  is the effort that is passed through dowels;  $t_k$ ,  $h_k$ ,  $l_k$  are the depth, height and width of a dowel;  $n_k$  is the number of dowels introduced to calculation.

In other words,  $t_k \times l_k$  is the area of compression (compaction) and  $h_k \times l_k$  is the area of cut per a single dowel. Dowels are involved in the node's operation unevenly - some take part in the operation to the full, others - partially, so the calculation is introduced with no more than three dowels:  $n_k \leq 3$ .

For a given connection node,  $h_k$  (a dowel's height) and  $l_k$  (a dowel's width) depends on the size of a void in the slab.

Standard industrially prefabricated slabs have frames in the near-



support regions, such slabs have a lateral reinforcement. Therefore, to test the strength of an upper shelf for detachment, it would suffice to consider only the work of a stretched transverse reinforcement.

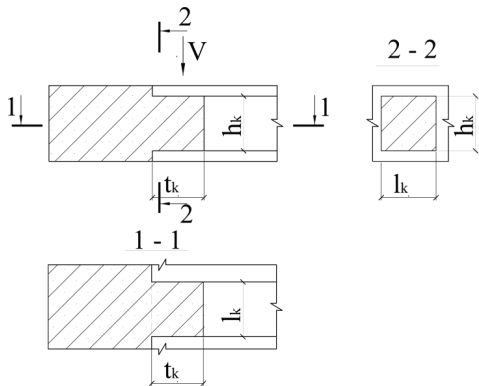

Fig. 10. Diagram for dowel calculation

Multi-void slabs with no formwork at which ribs do not host the transverse reinforcement must satisfy the criteria for durability in terms of the initial breaking of ends' concrete in the horizontal cross section.

The strength of an upper shelf of a slab for detachment, taking into consideration only the work of a stretched transverse reinforcement, is determined from formula:

$$V_{sw} = A_{sw} \cdot f_{ywd}, \tag{3}$$

where  $V_{sw}$  is the transverse force accepted by a transverse reinforcement;  $A_{sw}$  is the cross-sectional area of rods in the transverse reinforcement in the cross section of a slab;  $f_{ywd}$  is the estimated resistance to stretching for a transverse reinforcement (Fig. 11).

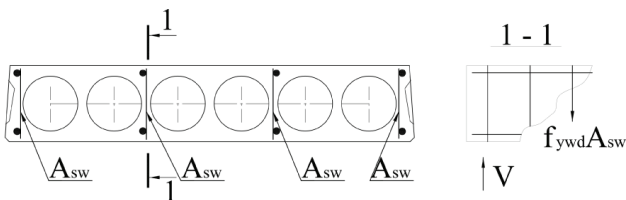

Fig. 11. Schematic for calculating the strength of an upper shelf of the slab for detachment, taking into consideration only the work of a stretched transverse reinforcement

The bearing capacity of the near-support region of a slab, considering only the work of concrete for the detachment of walls of the slab is determined from formula:

$$V_b = A_b \cdot f_{ctd}, \tag{4}$$

where  $f_{ctd}$  is the estimated resistance of concrete to stretching;  $A_b$  is the total area of concrete along the edges of a slab destruction near the support region (Fig. 12), which is determined from formula:

$$A_b = t_k \cdot \sum b_p, \tag{5}$$

where  $t_k$  is the depth of a dowel;  $\sum b_p$  is the sum of widths of all ribs in a multi-void slab.

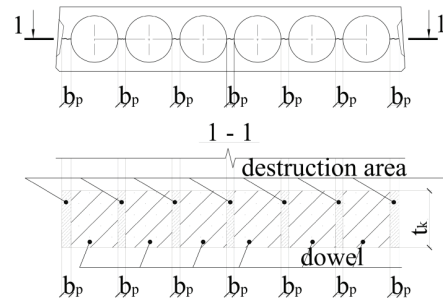

Fig. 12. Schematic for calculating the strength of an upper shelf of a slab for detachment, taking into consideration only the work of concrete for breaking the walls of a slab

The obtained values for strength were compared to the results from experimental study (Table 3).

Table 3

The transverse force, obtained from calculation using formula (3), and when testing the models of a flooring slab

| Slab No. | Obtained experimentally   | Value for transverse force when calculating for detachment along transverse reinforcement |                           |
|----------|---|---|---------------------------|
|          |   | estimated   | coefficient of divergence |
| P-1      | $N_{exp}=190 \text{ kN}; V_{exp}=95 \text{ kN}; M=109.25 \text{ kNm}$ | $V_{calc,w}=71.63 \text{ kN}$   | 1.33                      |
| P-2      | $N_{exp}=250 \text{ kN}; V_{exp}=125 \text{ kN}; M=37.5 \text{ kNm}$  | $V_{calc,w}=71.63 \text{ kN}$   | 1.75                      |
| P-3      | $N_{exp}=330 \text{ kN}; V_{exp}=165 \text{ kN}; M=49.5 \text{ kNm}$  | $V_{calc,w}=71.63 \text{ kN}$   | 2.3                       |
| P-4      | $N_{exp}=140 \text{ kN}; V_{exp}=70 \text{ kN}; M=21 \text{ kNm}$     | $V_{calc,w}=71.63 \text{ kN}$   | 0.98                      |
| P-5      | $N_{exp}=140 \text{ kN}; V_{exp}=70 \text{ kN}; M=21 \text{ kNm}$     | $V_{calc,w}=71.63 \text{ kN}$   | 0.98                      |
| P-6      | $N_{exp}=120 \text{ kN}; V_{exp}=60 \text{ kN}; M=18 \text{ kNm}$     | $V_{calc,w}=71.63 \text{ kN}$   | 0.84                      |

To test the convergence of estimation formulae and the results, obtained experimentally, it is required that the following condition should be met:

$$V_{calc,w} < V_{exp}, \tag{6}$$

where  $V_{calc,w}$  is the estimated value of transverse force;  $V_{exp}$  is the value for the transverse force obtained experimentally.

The experimental value for transverse force when testing sample P-6 is the smallest: it is equal to 60 kN. That is why this value is basic for comparison. The experimental value for transverse force that is equal to 60 kN is less than the value for the transverse force obtained from calculation for detachment, both for a transverse reinforcement and the calculation for concrete.

We can conclude that formula (3) does not satisfy condition (6) and requires a change (introduction of a step-down factor that is equal to 0.8, which takes into consideration the irregularity of involvement of a transverse reinforcement in the operation).

Thus, formula (3) is supplemented with a factor of 0.8. Then formula (3) will take the form:

$$V_{sw} = 0.8 \cdot A_{sw} \cdot f_{ywd}. \tag{7}$$

## 7. Discussion of results of studying the strength of a node that connects a precast slab and monolithic flooring joists in a precast monolithic flooring slab

Based on the research results, we have proposed the new structural solution for a precast monolithic flooring slab, as well as the new structural solution for the node that connects a precast slab and monolithic flooring joists. Underlying the structural solution for a precast monolithic flooring slab is the Universal open architectural-construction system of multi-storey buildings ARKOS (Series B1.020.1–7). A given system was designed at the Institute BELNIIB (Minsk, Belarus). As well as the similar structural system of flooring slabs «Sochi». High technical-economic and operational indicators were confirmed by years of experience in construction and are based on the results from research and developments at the Institute of BELNIIB.

The residential and public buildings in the system ARKOS with a height of up to 30 floors:

- energy efficient and have minimal costs of construction at minimal metal consumption;
- have modern consumer properties that include a higher level of comfort, free and combined planning solutions, implement various facilities without additional costs;
- ensure full utilization of available regional industrial base of construction and building materials, all weather construction, and a high rate of construction.

According to the authors of the series, it is the only practical structural system of buildings, in which:

- the precast monolithic discs of a flooring slab with the use of multi-void slabs are made flat, with no parts of the flooring slab protruding inside the volume of a building, providing the possibility to arrange enclosures at any desired location without restrictions;
- the thickness of a solid flooring slab of 12–14 cm ensures covering the spans of up to 7.20 m and larger.

The structural solution for a precast reinforced flat flooring slab is a flat disc of a flooring slab. The flooring slab consists of the precast multi-void slabs that are adjacent in one level to the monolithic load-bearing joists that have a height equal to the thickness of the slab (the so-called conditional girders). The design of the node that supports the flooring slabs on the joist is based on using concrete dowels (the concrete that fills the voids in slabs at concreting a joist).

The unusual design of the node supporting the flooring slabs on the joist, based on using concrete dowels (the concrete that enters the voids in slabs to 10 cm when concreting a joist), is still debated by some experts who doubt the reliability of the structure. Considering the introduction of modern design standards, which rule out the use of non-reinforced joints, a given design of the node requires improvement.

The structural solution to the framework and a precast monolithic flooring slab, designed at PSACEA, has some differences from the system of a precast monolithic flooring slab based on the series B1.020.1–7 aimed at improving the reliability of a flooring slab structure:

1. The dimensions of multi-void slabs in each cell are made shorter while the monolithic part of load-bearing beams, as a result, is wider (the width of a joist is 900 mm). This makes it possible to significantly increase the rigidity of flooring slabs using the slabs with a thickness of 22 cm when exposed to vertical load; the upper and lower working reinforcement of bearing joists can be comparatively easy arranged in a single layer.

2. The height of the cross-section of load-bearing joists, in order to reduce the consumption of metal for their reinforcement, is increased by the thickness of the screed of the floor (50 mm), that is the height of a joist is 270 mm at the thickness of flooring slabs of 220 mm.

3. Each joint between the slabs hosts a reinforced concrete dowel with a width of 100 mm, which improves the spatial rigidity of the disc in a flooring slab and ensures that work of the precast slabs when calculating supporting cross-sections involves a monolithic flooring joist. When calculating the span cross-sections of the joist work of the precast slabs is disregarded.

4. To ensure the strength of the supporting node, concrete dowels in the voids in slabs host additional frames with a transverse reinforcement. The length of dowels is accepted equal to 150 mm (for the series B1.020.1–7 – 100 mm).

The proposed changes to the structural solution for a precast monolithic flooring slab are based on the analysis of results obtained from experimental research into the samples of a flooring slab, as well as from field testing of a fragment of the building's frame.

We tested the models of a flooring slab using a specially designed experimental setup for a «force frame» at the testing laboratory of PSACEA. We registered vertical displacements (deflections), deformations of the concrete surfaces, the width of crack disclosure. All experimental samples were brought to destruction. All the examined models from the same series of a precast monolithic flooring slab demonstrated the same deformation pattern. It was established that deflections in the models of a flooring slab increase evenly with an increase in load, without sharp jumps (Fig. 7).

Cracks in the models of a flooring slab were born logically and predictably. When conducting the experiment, we registered normal cracks when testing the models for bending. When testing the models for cutting, we registered the inclined cracks only, formed in the precast slab near a support. At the time of destruction, there formed a normal crack in the upper compressed zone of the slab at a distance equal to the length of the dowel, from the junction between a precast and a monolithic element, as a result of breaking the upper shelf of the slab by the dowel itself. The destruction occurred at load magnitudes of 140...120 kN, at the initial width of the crack disclosure of 0.2...0.3 mm, which does not exceed the maximum permissible value. The formation of normal cracks along the center of the slab was not registered even at the time of destruction of the structure of the junction along a sloping cross section. It was concluded that for a given type of the flooring slab it is exactly the node of joint between a precast slab and a monolithic flooring joist that is the weakest spot.

The main factor revealed during the experiments was the participation in work of the monolithic joist of the multi-void flooring slab, which is the case for an actual structure, which is confirmed by other studies [16, 18]. That leads to the formation of normal cracks near a support in the multi-void flooring slab in a compressed region of concrete, with the initial formation of cracks in the inclined cross section of a precast slab. The results obtained indicate that the exhaustion of bearing capacity of the connecting node occurs when the boundary state is reached in the inclined cross section of the slab.

In other words, results from the experiment confirm that when the node that connects a precast hollow slab and a monolithic flooring joist is fabricated using dowels, the slab is involved in a joint work with the joist. Thus, in the transverse direction of a slab there are stretching efforts that lead to the

formation of cracks, particularly in the absence of any reinforcement (structural or working) of the slab in the transverse direction (especially for slabs with no formwork). This fact indicates that the greater the length of the dowel, the greater part of the inclined cross section of a multi-void slab is included in work, which is why the accepted greater length of a dowel of 150 mm instead of 100 mm [16, 19] is structurally justified.

The result obtained requires taking structural measures, as well as the development of a procedure for calculating the transverse reinforcement of a slab in order to avoid the formation of cracks in a multi-void slab.

The fact that work involves a precast flooring slab is confirmed by the on-site tests of the fragment of a building's frame [23]. The results from experimental studies have shown that the precast monolithic flooring slab works, in terms of deformability, as a solid monolithic one (Fig. 9). In our case, the experimental flooring slab was not brought to destruction.

It was established that deflections in the investigated part of the flooring slab increase uniformly with an increase in loading, without sudden jumps (Fig. 8). The maximum value for deflection under a load of  $11.7 \text{ kN/m}^2$  was 18.55 mm for the slab and 14.64 mm for the joist. The magnitudes for deflections, even when loading up to a load of  $11.7 \text{ kN/m}^2$ , were significantly less than the regulatory permissible deflections, which equal 40 mm. We registered neither destruction, nor crack formation. This was evidenced by the installed devices and the visual inspection of the structure. In addition, it was found that there was no any mutual displacement of the precast slab and monolithic flooring joist along the connecting joint, confirmed by results from instrumental and visual examination.

The structural solution for the proposed precast monolithic flooring slab using a dowel-based connection between a monolithic flooring joist and a precast slab is suitable for installing flooring slabs that span 6 m or larger and can accept loads from buildings designed for housing and civil purposes. A given result was obtained by comparing the destructive, experimentally established effort, with efforts that occur in buildings for housing and civil purposes (Table 1).

Our full scale experimental study of the improved precast monolithic flooring slab has made it possible to draw conclusions on that the designed structural solution for a flooring slab has sufficient hardness, fracture toughness, and carrying capacity and is perfectly suitable for installing flooring slabs of large spans in residential and public buildings.

For the new structural solution, we have proposed a procedure for calculating the node that connects precast slabs and monolithic flooring joists. Initially, as a result of performed tests, we determined that the structural solution for the node that connects a precast slab and a monolithic flooring joist had no required bearing capacity.

The bearing capacity, calculated according to acting regulations, amounted to 71.63 kN, which exceeds the bearing capacity obtained from the tests (Table 3). That is why the devised calculation procedure requires the introduction of changes to regulations, namely it is necessary to introduce a step-down factor equal to 0.8, which would take into consideration the irregularity at which a transverse reinforcement participates in work.

The current research fails to consider that one does not account for the spreading efforts that occur in the disc of a flooring slab under loading. It is known the accounting for spreading makes it possible to reduce, by 30...40 %, the amount of internal efforts in all estimated cross sections of a flooring slab's elements and to reduce, within the same

range (by 30...40 %), consumption of steel for reinforcing a flooring slab in general. Therefore, the proposed structural solution for a precast monolithic flooring slab have additional reserves. The above does not affect the results obtained and is a task for the further research.

---

## 8. Conclusions

---

1. We have improved the design of a flat precast monolithic flooring slab, composed of the precast hollow slabs and monolithic flooring joists. The structural differences are aimed to enhance reliability of the flooring slab structure. To ensure the strength of the supporting node, concrete dowels host additional frames with a transverse reinforcement. The length of dowels is accepted to equal 150 mm. Dimensions of the multi-void slabs in each cell are made shorter, while the monolithic part of load-bearing joists, as a result, is wider (the width of a joist is 900 mm). That makes it possible to significantly improve the rigidity of flooring slabs with slabs of thickness 22 cm under the action of a vertical load, while the upper and lower working reinforcement of bearing joists can be comparatively easy arranged in a single layer. At each joint between the slabs we install a reinforced concrete dowel with a width of 100 mm, which improves the spatial rigidity of the disc in a flooring slab and ensures that the precast slabs are involved in work when calculating the supporting intersections in a monolithic flooring joist. The height of intersection of the load-bearing joists, in order to reduce metal consumption for reinforcing them, is increased by the thickness of the screed of the floor (50 mm), that is the height of a joist is 270 mm at the thickness of flooring slabs of 220 mm.

2. The procedure for laboratory experimental research has been devised. The accepted method of experimental research is testing the load with bringing the sample to destruction. Given the absence of data on destruction of the node that connects the precast slabs and monolithic flooring joists, our procedure has made it possible to specify the loads at which first normal or inclined cracks appear, as well as their propagation; determine the character of concrete deformations under loading at the most characteristic places of samples destruction; to determine the deflection of samples of a precast monolithic flooring slab; define the character of destruction of the flooring slab's samples; to determine bearing capacity of the flooring slab's samples when tested. It was established that when testing the models for bending there appear normal cracks in a precast slab, without destroying the node that connects precast slabs and monolithic flooring joists. When testing models for cutting, we registered the inclined cracks only formed in the precast slab near a support as a result of exhaustion of bearing capacity for the inclined cross section. The results obtained have made it possible to devise a procedure for calculating the node that connects precast slabs and monolithic flooring joists. It was established that the node that supports a slab on a monolithic flooring joist, using a reinforced concrete dowel, has a 1.42-fold strength margin compared to the maximum possible value for transverse force at facilities for trade purpose with a span of 8 m.

3. The procedure for field testing of a flat precast monolithic flooring slab when exposed to the static loading with a vertical uniformly-distributed load aimed at assessing the bearing capacity and deformability has been devised. The accepted method for experimental study is the method of field testing using loading in line with a slab scheme implying

bringing the load to control in terms of deformability in accordance with DSTU B V2.6–7–95. The devised procedure has made it possible to perform field tests of the flooring slab directly at a facility being constructed for trade and exhibition center and to define: the deformability and strength of a flooring slab exposed to the action of vertical static loading; the character of concrete deformations under loading at the most characteristic places of possible destruction of a flooring slab; the actual values for deflections under control load during testing; the absence of normal and inclined cracks in the flooring slab's elements loaded with a control load.

4. We have devised a procedure for calculating the node that connects a precast hollow slab and a monolithic flooring joist that implies determining the strength of a dowel for cutting and for compression; determining the strength for detachment of the slab's shelf or when breaking its walls. The devised calculation procedure requires the introduction of changes to regulations, namely it is required to introduce to the formula for calculating the strength of the upper shelf of a slab for detachment of a step-down factor equal to 0.8, which takes into consideration the irregularity at which a transverse reinforcement participates in work.

#### References

1. Ayrapetov, G. A., Bretshnayder, B. A. (1996). *Stroitel'stvo v Germanii*. Moscow, 283.
2. Bayshev, Yu. P., Plohih, V. I. (2007). Povyshenie effektivnosti zhelezobonnykh perekrytiy zdaniy. *Stroitel'nye materialy, oborudovanie tekhnologii XXI veka*, 4, 20–22.
3. Aïtcin, P.-C. (2000). Cements of yesterday and today. *Cement and Concrete Research*, 30 (9), 1349–1359. doi: [https://doi.org/10.1016/S0008-8846\(00\)00365-3](https://doi.org/10.1016/S0008-8846(00)00365-3)
4. Hadi, M. N., Sharafi, P. Teh, L. H. (2012). A new formulation for the geometric layout optimisation of flat slab floor systems. *Australasian Structural Engineering Conference (ASEC 2012)*. Australia: Engineers Australia. Available at: <https://ro.uow.edu.au/cgi/viewcontent.cgi?referer=&httpsredir=1&article=3014&context=eispapers>
5. Bangash, M. Y. H. (1992). *Structural details in concrete*. Oxford, Blackwell scientific publications, 107–115.
6. McCormac, J. C., Nelson, J. K. (2005). *Design of Reinforced concrete*. Wiley, 81–100.
7. Gluhovskiy, A. D. (1956). *Zhelezobonnye bezbalochnye perekrytiya dlya mnogoetazhnykh zdaniy*. Moscow, 3–10.
8. Patil, K. S., Gore, N. G., Salunke, P. J. (2014). Minimum Cost Design of Reinforced Concrete Flat Slab. *International Journal of Recent Technology and Engineering (IJRTE)*, 2 (6), 78–80.
9. Pavlikov, A. M., Harkava, O. V., Bezrukavyy, D. V. (2013). Vprovadzhennia bezryhelno-bezkapitelnoi karkasnoi konstruktyvnoi systemy v proektuvannia budivel pid sotsialne zhytlo. *Resursoekonomni materialy, konstruktsiyi, budivli ta sporudy*, 27, 352–359.
10. Chen, W., Richard Liew, J. (Eds.) (2002). *The Civil Engineering Handbook*. CRC Press, 2904. doi: <https://doi.org/10.1201/9781420041217>
11. Pessiki, S., Prior, R., Sause, R., Slaughter, S. (1995). Review of Existing Precast Concrete Gravity Load Floor Framing Systems. *PCI Journal*, 40 (2), 52–68. doi: <https://doi.org/10.15554/pcij.03011995.52.68>
12. Huselytsia, A. P., Shandruk, P. P. (2002). *Konstruktsiyi bahatopoverkhovykh karkasnykh budynkiv ta yikh rozrakhunkiv*. KNUBA. Kyiv, 72.
13. Semchenkov, A. S. (2008). Obosnovanie regional'no-adaptiruemoy industrial'noy universal'noy sistemy "RADIUSS". *Beton i zhelezobeton*, 4, 2–6.
14. Chto takoe «KUB-2,5». Available at: <http://zavod-zhbi.com.ua/tehnologiya-kub-2-5/chto-eto/>
15. Moskalenko, M. (2010). Budynky, pobudovani za systemoiu KUB-2.5, zdadni zabezpechyty spozhyvachiv dostupnym i, holovne, yakisnym zhytлом. *Vechirnia Poltava*, 49 (929), 2.
16. Semchenkov A. S. (2010). Puti vyhoda sbornogo domostroeniya iz krizisna. *ZhBI i konstruktsii*, 2.
17. Markov, N. A., Soldatov, A. E. (1993). Primenenie karkasnykh zdaniy s natyazheniem armatury v postroechnykh usloviyah. *Beton i zhelezobeton*, 6, 19–20.
18. Mordich, A. I., Vigdorichik, R. I., Belevich, V. N. (2000). Mnogoetazhnye zdaniya po serii B1.020.1-7 so sborno-monolitnymi karkasami i ploskimi perekrytiyami iz mnogopustotnykh plit. *Sovremennyye arhitekturno-konstruktivnyye sistemy zdaniy i sooruzheniy, novyye stroitel'nye materialy i tekhnologii*. Minsk, 3–22.
19. Mordich, A. I. (2008). Effektivnyye sborno-monolitnyye karkasnye konstruktsii zdaniy – osnova dlya dostupnogo i komfortnogo zhil'ya. *Populyarnoe betonovedenie*, 6, 96–100.
20. Mordich, A. I., Vigdorichik, R. I., Belevich, V. N., Ivaschenko, Yu. (1999). Unifitsirovannaya otkrytaya karkasnaya sistema zdaniy s ploskimi perekrytiyami, seriya B1.020.1-7. *Arhitektura i stroitel'stvo*, 6, 24–26.
21. Savitskiy, M. V., Butskaya, E. L. (2013). Durability and cost-effectiveness of precast and cast-in-situ deck. *Techniczne nauki. Chemia i chemiczne technologie. Budownictwo i architektura. Przemysl: Nauka i studia*, 35 (103), 77–83.
22. Savitskiy, N. V., Butskaya, E. L. (2010). Ploskoe zhelezobonnoe sborno-monolitnoe perekrytie. *Visnyk natsionalnoho universytetu «Lvivska politekhnika»*, 662, 323–327.
23. Savits'kiy, N. V., Butskaya, E. L., Chernets', V. A. (2011). Rezul'taty naturnih ispytaniy fragmenta sborno-monolitnogo perekrytiya. *Stroitel'stvo, materialovedenie, mashinostroenie*, 61, 382–387.
24. Savitskiy, M. V., Butska, O. L., Piradov, K. A., Kovtun-Gorbachova, T. A. (2015). Knot strength interface pre-slabs and monolithic beams precast and cast-in-situ deck. *Stroitel'stvo. Materialovedenie. Mashinostroenie. Seriya: Sozdanie vysokotekhnologicheskikh ekokompleksov v Ukraine na osnove kontseptsii sbalansirovannogo (ustoychivogo) razvitiya*, 81, 185–190. Available at: <http://smm.pgasa.dp.ua/article/view/56627/52826>