

Розроблено технології отримання сферичних днищ та циліндричних обичайок в багат шаровому виконанні з квазішарового матеріалу та ущільнення багат шарової стінки елементів військової техніки. Необхідність цих досліджень пов'язана з підвищенням живучості та усуненню осколочної дії на живу силу й техніку, конструкцій в багат шаровому виконанні, в яких використовуються судини високого тиску (підводні човни, судини для вогнеметів, елементи для бронетехніки).

Представлені експлуатаційні умови, в яких найбільш ефективно використовувати конструкції, що виготовлені із шаруватих конструкційних матеріалів. Описано їх переваги в умовах експлуатації та виробництва. Найбільш повна реалізація ефективності досягається при щільному приляганні шарів конструкції або при використанні квазішаруватих матеріалів. Вирішення цього завдання можливе при використанні енергії бризантних вибухових речовин. Експериментально встановлено, що вибухове навантаження призводить до збільшення ударної в'язкості та балістичної стійкості оброблених матеріалів. Проведено аналіз різних варіантів способів ущільнення багат шарової стінки та запропоновано найбільш ефективні технології.

В результаті досліджень встановлені технологічні параметри процесів, вимоги до технологічного обладнання та оснащення.

Важливість представлених досліджень пов'язана з підвищенням боєдатності, живучості військової техніки та особового складу

Ключові слова: зварювання вибухом, ущільнення багат шарової стінки, композиційні матеріали, квазішаруваті матеріали, бронетехніка

A SEARCH FOR TECHNOLOGIES IMPLEMENTING A HIGH FIGHTING EFFICIENCY OF THE MULTILAYERED ELEMENTS OF MILITARY EQUIPMENT

M. Zagirnyak

Doctor of Technical Sciences, Professor, Rector
Department of Electric Machines and Devices**
E-mail: mzagirn@kdu.edu.ua, mzagirn@gmail.com

V. Zagirnyak

Senior Lecturer*
E-mail: vzagirn@gmail.com

D. Moloshtan

Postgraduate student*
E-mail: vldrag@kdu.edu.ua

V. Drahobetskyi

Doctor of Technical Sciences, Professor,
Head of Department*
E-mail: vldrag@kdu.edu.ua

A. Shapoval

PhD, Associate Professor*
E-mail: alexshap.as@gmail.com

Department of Manufacturing Engineering

**Kremenchuk Mykhailo Ostrohradskyi National University
Pershotravneva str., 20, Kremenchuk, Ukraine, 39600

Received date 18.07.2019

Accepted date 08.11.2019

Published date 10.12.2019

Copyright © 2019, M. Zagirnyak, V. Zagirnyak, D. Moloshtan, V. Drahobetskyi, A. Shapoval

This is an open access article under the CC BY license

(<http://creativecommons.org/licenses/by/4.0>)

1. Introduction

In modern conditions of production and technology development, products made of layered composite materials occupy a significant place among many design solutions. The effectiveness of layered structures is confirmed by the emergence of layering principle in the design and manufacture of tooling and processing method [1–3].

Consumers of layered metal compositions for the production of a wide class of parts and equipment are almost all industries, including defense [4].

Layered structures have increased strength, operational reliability and safety, are easier to manufacture and open up new aspects in increasing productivity [5]. Layered structures are most effective to use in shock, pulse and explosive loading. Under operating conditions of multilayered structures, cracks and other defects are localized in one layer and do not lead to the destruction of the entire structure. Pre-stresses can be created in a multilayered wall, which in

some cases contributes to a more uniform stress distribution. The presence of an auxiliary contact surface of individual layers and reduced bending stiffness of the multilayered wall increase the time of collision of a flying object against the wall. The concentrated impact force acting on the multilayered wall is significantly reduced, and ballistic resistance is increased. In addition, the coefficient of restitution significantly affecting the momentum for the multilayered wall is lower than for the monolithic one. In the case of impact of the flying object against the multilayered wall, most of the kinetic energy will go to the rapprochement and compaction of individual layers, a smaller part of it will go to change the shape and origin of destruction centers.

Multilayered wall has a large margin of ductility compared to monolithic. Multilayered structures are characterized by plastic fracture as the process spreads gradually from one layer to another. Thin sheet has improved mechanical properties and good weldability. Important advantages of multilayered vessels compared to monolithic ones include

simplicity of manufacturing structures of dissimilar materials. To prevent hydrogen corrosion, monolithic wall vessels are made entirely of high-alloy hydrogen-resistant steels or thick bimetal, requiring high-temperature heat treatment after welding. In a multilayered vessel, high-alloy hydrogen-resistant steel is used only for the central shell. Fundamentally new operational capabilities are opened by so-called quasi-layered materials. The main feature of such materials is that under static loading these compositions behave in the same way as ordinary single-layer (monolithic) metal, and under shock, vibration, and dynamic loading – like layered metal. Also, a distinctive feature of quasi-layered materials is the same adhesion strength of layers over the entire contact surface. The latter should be slightly lower than the strength of the basic material [6].

Multilayered structures also have significant technological advantages. Small layer thickness determines the simplicity of technological operations, low complexity of equipment, reduction of the range of materials used. This reduces the time of developing new products, especially in one-off and small-scale production.

Therefore, studies related to improving the operational characteristics of layered products, in particular, ballistic resistance and survivability of the structure as a whole, are extremely relevant. No less relevant are the problems of preventing the transmission of cracks to adjacent layers, reducing beyond-armor and fragmentation effects on manpower and equipment.

Effective implementation of the complex of tasks of layered structures production promises significant economic benefits and advantages in conditions of combat operations.

2. Literature review and problem statement

In [7], the design criteria of armor resistance of protective materials developed by different methods are described and compared. For explosion-welded bimetal, the Stiglitz design criterion is recognized as optimal. However, bimetal steel 65G+ aluminum AD0 has high density and therefore cannot be used for the production of body armor, armored vehicles and pressure vessels – components of flamethrowers.

The work [8] describes the processes of joint rolling of multilayered composite materials of carbon and high-alloy steels, which allows obtaining compositions with a thickness of less than 13–15 mm, but this technology is not applicable for the production of spherical parts.

In [9, 10], the issues of increasing the survivability of multilayered structures, ballistic resistance, beyond-armor and fragmentation effects, etc. are rather deeply and fully covered. In [11], the results of studies on increasing the ballistic resistance of composite multilayered armor by means of additional pulse action are presented. Small-amplitude wave action leads to increased ductility of brittle materials without changes in strength [12].

In the production of composite materials, much attention is paid to the formation of structures and chemical heterogeneity, phase transformations taking place at the interface of materials. Such an approach is proposed in the work [13], devoted to the production of structured composite materials of a new generation.

In [14], the problem of determining the optimal thickness ratio of elements of layered materials under the shock-wave action of bullets is solved. The results of ballistic tests are also given. The manufacture of multilayered products

is also possible by press drawing and high-temperature rolling [15, 16]. However, this does not provide firm adhesion of layers. Conventional sizing methods of the multilayered wall compaction process do not give positive results.

The studies [17, 18] did not solve the issues of giving shear strength to the outer layers and reducing the amplitude of the shock-wave effect on the protected object.

In [19], to prevent transmission of cracks to adjacent layers, a gap (0.5 mm) is left, which is filled with an elastomer, polymer or metal materials, which gives shear strength to the outer layer.

It is advisable to produce a wide range of parts in the conditions of one-off and small-scale production using a universal method of peen forming [20].

However, the issues of improving the operational characteristics of products of quasi-layered materials and layered uniform materials by compaction of the multilayered wall and creating a certain level of interlayer strength are practically not studied and difficult to implement by conventional processing methods.

In general, a review of the existing methods for manufacturing multilayered products and structures shows that the main difficulties are related to the elimination of gaps in the multilayered wall and provision of firm adhesion of layers until their setting. To date, the use of pulse processes in this area is unreasonably low, despite their high accuracy and energy capabilities.

However, operational and technological advantages of multilayered products can be fully realized only when the problem of multilayered wall compaction is solved. No less important is the problem of eliminating lamination in the heat-affected zone of the weld, making quasi-layered materials and eliminating butt joints of cylindrical shells with monolithic material bottoms.

For the full implementation of operational characteristics of products of layered composite materials, it is necessary to solve the problems of sizing and compaction of the multilayered wall or making quasi-layered materials, providing conditions for welding multilayered parts together.

However, it is fundamentally impossible to technologically solve the problem of filling the gap between the layers of spherical and cylindrical vessels.

In [21, 22], technology options for the production of pressure vessels of bimetallic materials are proposed. However, electroslag welding is not rational in this case due to technological limitations.

An option to overcome technological difficulties may be a technique that provides the production of quasi-layered materials or effective compaction of the multilayered wall. In the latter case, the layer interface should have higher ductility. Studies in this direction have been carried out in [23], but the issue of structural and chemical heterogeneity at the layer interface has not been resolved.

To obtain full operational characteristics of products of layered composite materials, it is necessary to solve the problems of sizing and compaction of the multilayered wall or making quasi-layered materials, providing conditions for welding multilayered parts together.

3. The aim and objectives of the study

The aim of the study is to develop technologies that enhance and implement the operational characteristics and

advantages of layered products while maintaining the mechanical properties of processed materials and forming layer separation properties.

To achieve the aim, the following objectives were set:

- to develop highly effective technologies of compaction and sizing of layered blanks for multilayered structures and production of parts of quasi-layered materials with desired properties at the layer interface for the compensation of shock loads and crack shielding;

- to evaluate the effect of explosive loading on the operational and mechanical properties of materials used in multilayered structures.

4. Materials and methods for studying the processes of multilayered wall compaction and production of quasi-layered materials

The basis of the sizing process is that elastic unloading depends on both physical and mechanical properties of the blank material and stress state, and under certain conditions the elastic aftereffect disappears. This is realized either at pressures $P=(1.8\div 2)\sigma_s$, or with double bending of deformed blanks, or with preliminary drawing or compression of the deformed stack. It is most simple to perform multilayered wall compaction operations and achieve high accuracy of edges of manufactured parts using the energy of high explosives.

It turned out impossible to solve the problem of multilayered wall compaction using conventional stamping methods. This is because traditional equipment practically cannot implement a stress state scheme during compaction, in which unloading is practically zero.

To implement the technology of sizing and compaction of the multilayered wall in the manufacture of products of layered and quasi-layered materials using the energy of high explosives, the following methods can be used:

1. Stamping with hold-down and supply of blanks flanges. Flat blanks are stacked and stack deformation is performed. To ensure compaction of the multilayered wall, it is necessary to create conditions on flange parts of blanks for activating the movement of the inner layers and braking of the outer ones. During drawing, layers are compacted due to the difference in meridional deformations. In this process, a high degree of compaction is achieved, but in some cases, thickness variation of the inner and outer layers reaches 50 %.

2. Before drawing, flanged parts of blanks are welded (explosion welding, diffusion welding). This prevents stability loss of layers and increases the deformability of the entire stack.

3. Pre-forming of the stack with subsequent sizing by hitting against the sizing die face.

The gap between the inner blank of the stack and the forming surface of the sizing die shall be sufficient to gain kinetic energy during plastic impact. In this process, it is difficult to avoid welding of the inner layer to the die face.

4. The stamped blank stack is put in the die and subjected to pulse loading. The choice of stamping method depends on the material of blanks. If the material is prone to cracking under dynamic loading, preference is given to stamping processes with a low strain rate.

5. Sizing of the preformed blank stack. Unlike the previous version, the profile of each blank has a strictly defined shape. The shape of the surface profile is determined from the condition that one-dimensional throwing provides a constant angle between the tangents to the blank and die

surfaces at any point of impact. The constant angle γ_i between the tangents to the contact surfaces of the blanks and the external blank with the die face (Fig. 1).

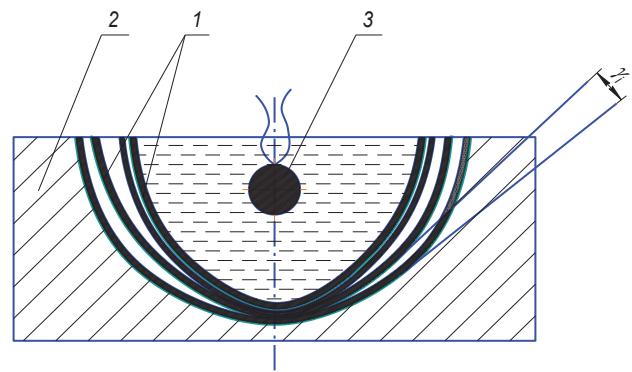

Fig. 1. Scheme of multilayered wall compaction: 1 - blank stack; 2 - die; 3 - explosive charge

Compaction can be carried out either of the entire stack simultaneously, or in layers.

Sizing of cylindrical and conical blanks is carried out by linear explosive charges, and the mode of double bending glancing collision is easily implementable.

Parameters of external load during compaction and sizing are selected from the condition of providing a traveling pulse pressure wave by selecting the shape, weight, location and initiation place of explosive charge. If it is impossible to create a traveling loading wave, the profile shape of sized and compacted blanks is selected.

It should also be noted that in the applied schemes of multilayered wall compaction, it is not always possible to ensure good adherence of ends or free faces of layered blanks. To prevent deformation and lamination of blanks in these areas, it is necessary to use spall elements. The scheme of compaction with spall elements made of material of the inner layer and located on the edge side and free surface of the die are shown in Fig. 2.

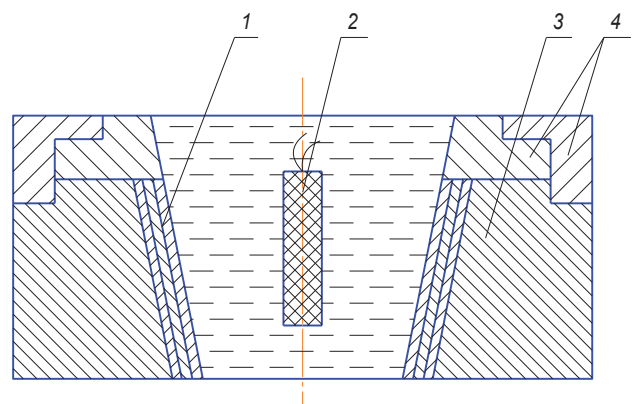

Fig. 2. Scheme of compaction with spall elements: 1 - blank stack; 2 - explosive charge; 3 - die; 4 - spall elements

Instead of spall elements, false build-up can be used, which is close in mass per unit area of the material (Fig. 3).

To eliminate the non-homogeneity of deformations and compaction in finishing operations, it is advisable to use

shielding of end gaps. Explosive loading of the multilayered shell with a traveling wave provides good compaction. At the same time, the question arose of how this type of loading affects the operational properties (toughness, crack resistance, etc.) of the finished product, in particular, VNS-17 maraging steels. In this case, during the explosive compaction of the multilayered wall, it is necessary to maintain a set of strength properties that ensure high performance in combat conditions. Therefore, studies are needed on the effect of explosive loading on metal properties. When forming a program of experimental studies, it is necessary to take into account factors affecting the physical and mechanical characteristics of material during explosive loading. These factors include pressure on the elements of the multilayered blank, duration of pulse loading, strain rate of the blanks of the multilayered composition, speed of the contact line of collided blanks or linear momentum transfer, heating temperature and cooling rate of material. Considering that parameters of explosive loading can be varied within rather wide limits, a set of experimental studies was carried out under various conditions of pulse exposure.

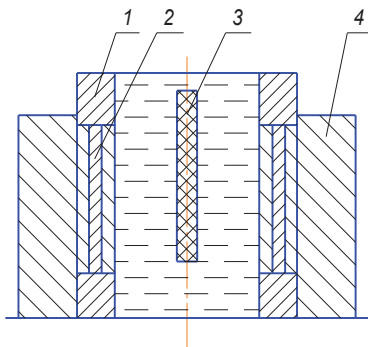

Fig. 3. Compaction scheme using false build-up:
1 – false build-up; 2 – layered blank;
3 – explosive charge; 4 – die

For this purpose, VNS-17 steel samples were loaded with a traveling explosive load. To vary the deformed state of blanks, pulse duration and loading pressure, intermediate layers of porous and elastic materials were used.

Under such loading, the test samples retained high toughness and mechanical properties.

Explosion stamping of multilayered spherical shells was experimentally evaluated using two schemes. The first is drawing of the blank stack without hold-down of the flange part, the second is with hold-down. Experimental studies were carried out on the non-hold-down stamping of multilayered blanks with a relative thickness $h_3/D_3=0.007-0.02$, where h_3 is thickness, D_3 is the diameter of the blank of 08KP, 3, 20, 09G2S, VNS-17 steel, D16AMO aluminum.

The method of producing multilayered spherical shells was investigated, the essence of which lies in the fact that areas of the blank stack most prone to stability loss were concreted by explosion welding. To do this, explosion welding of the flange part of the blank stack was performed before deformation.

A welding scheme is preferable where the explosive layer thickness gradually decreases from a maximum value to zero, which prevents double bending of the blank stack, and, therefore, eliminates the stress concentrator in the boundary area of explosives.

Stamping of the stack was carried out according to the scheme of non-hold-down drawing. Blank material – St. 3 and 09G2S steel, diameter – 0.174 m, thickness – $(1 \div 1.4) \cdot 10^{-3}$ m, die diameter – 0.125, inlet radius – $20 \cdot 10^{-3}$ m, basin diameter – 1 m.

With the adhesion strength of the layers in the stack equal to $(0.7 \div 0.85)\sigma_v$, no lamination was observed during the stamping process, corrugations and other defects were not formed.

During non-hold-down explosive drawing, the blank stack was placed on a die lubricated with fatty oil 1–13. The hold-down ring was mounted so that a gap was formed between it and the blank. Three sheet blanks of D16AMO $1.2 \cdot 10^{-3}$ m thick each, 0.12 m in diameter, previously ground to each other, were stamped simultaneously. ED-8 electric detonators were used as a charge. The explosion distance, counted from the upper blank surface to the lower cut of the detonator, was 0.05 m. After explosive deformation, the blanks remained connected. Fine corrugations formed on the entire surface of the flanges. Alignment of the upper and lower blanks relative to the middle one was not violated. The adhesion strength of the layers is low and after stamping the layers are easily separated from each other. The distribution of thinning in each individual blank is approximately the same.

During hold-down drawing of flanges, corrugations are not formed, and thinning in the blanks and adhesion strength of the layers depend on friction forces between the blank and the die, between the blanks and blanks with the hold-down ring. So, when applying abrasive powder to the surface of the die flange and lubricating the hold-down ring with fatty oil 1–13, firm adhesion of the layers is obtained.

The results of the experiments showed the possibility of obtaining multilayered spherical shells with firm adhesion of layers. In this case, however, the distribution of thinning, material utilization, number of transitions and cost of auxiliary operations are 3–5 times higher compared to the non-hold-down drawing. At the same time, the process of hold-down drawing is more stable and does not require high accuracy when setting the charge and orienting the blanks.

The experiments to identify the possibilities of obtaining high-quality compaction of cylindrical multilayered part were carried out using one or more concentrated charges. As blanks for multilayered shells, twisted and composite shells were used. Three blanks of different diameters were used. Two shells were expanded with a spherical charge so that the parts freely fit into each other.

As a result of the experiments, satisfactory compaction of the layers was obtained, but there are places of local separation.

Also, experiments were carried out on lining of a $\varnothing 0.8$ m shell with a thickness of $4 \cdot 10^{-3}$ m and a height of 1 m with four shells of $2 \cdot 10^{-3}$ m thickness, where each had a diameter by $6 \cdot 10^{-3}$ m smaller than the previous one. Lining was made in two transitions. At the first transition, two shells were compacted with a linear charge located on the axis. 4 lines of detonating cord were used as a charge.

Compaction at the lower end was carried out using plasticine. The upper end of the shells was not compacted (remained above the water level in the basin). At the second transition, two more shells were inserted. The stack was compacted at the ends, turned over and lowered into the basin. Compaction was carried out with the same charge.

In addition, lining was performed using a system of concentrated charges $G=0.04$ K2 4 pieces each also in two transitions.

After explosive deformation, both with the linear charge and with the system of concentrated charges, complete adherence was observed, the size of the outer shell did not change.

It was not possible to meet high requirements for compaction of scroll shells with the help of free expansion with pulse loading. Based on the experience of hydraulic explosion sizing, the required accuracy can be achieved using high-precision tooling. For this purpose, the scroll shell was compacted into the die.

A twisted shell of $\varnothing 0.4$ m and a height of 0.195 m, the number of turns 3, sheet thickness of $5 \cdot 10^{-3}$ m was used as a blank. The material of the blank was 09G2SF steel. Explosive compaction was carried out by spherical and cylindrical charges.

Measurements of strains in the multilayered wall were made at four equidistant points ($\delta_1, \delta_2, \delta_3, \delta_4$, respectively).

When using cylindrical charges, the total explosive mass is reduced 1.4–1.5 times compared with spherical charges, the aftereffect of elastic unloading is reduced, the variation in the inner shell sizes and thicknesses in the sections perpendicular to the axis is decreased.

When compacting and sizing multilayered structures, the conditions of explosive loading are close to those of explosion welding. In some cases, when manufacturing multilayered parts, technical and technological requirements do not allow welding (sticking or setting) of interlayer surfaces. This technological requirement is in some cases extremely difficult to meet. In the vicinity of the contact point during glancing collision, the interlayer surfaces are cleaned and a cloud of dispersed particles, which fly out of the collision zone is formed [24]. This provides the release of internal metal particles to the surface and tight contact of the surfaces. The combination of high contact pressures exceeding the yield strength of the deformed metal and the presence of contact surface slipping favor adhesion, welding.

Based on these assumptions, experiments were carried out with two goals. The first is aimed at obtaining high-quality compaction without adhesion of layers. The second is to study the possibility of producing quasi-layered materials.

The experiments were made on 09G2S maraging steel samples with a thickness of $4 \cdot 10^{-3}$ m and a diameter of 0.175 m.

Mutual arrangement of the samples and external load parameters in this series of experiments ensured that the plates were welded together. Moreover, adhesion of the samples occurred without preliminary surface cleaning. Welding was performed with a gap of $1 \cdot 10^{-3}$ m with an explosive weighing 0.5 kg.

In order to prevent welding of the blanks, it was proposed to use an intermediate separation layer between the contact surfaces in the deformation zone.

The test results are presented in Table 1, which show that the adhesion strength of the layers is lower than the strength of the base material and meets the requirements for quasi-layered materials.

During the experiments to study the possibilities of producing quasi-layered materials [25], the welding gap changed from $h_w = (0.2 - 1.0) \cdot 10^{-3} \delta$ m. In these cases, a weld joint was obtained over the entire surface of the samples. Welded samples were tested for tear and shear at the E. O. Paton Electric Welding Institute (Kyiv, Ukraine).

Table 1

Mechanical tear and shear tests of multilayered samples

Material	Yield strength, MPa	Ultimate strength, MPa	Welding parameter, r	$\frac{h_w'}{\delta_1}$	$\frac{h_w''}{\delta_2}$	Tear of layers, MPa	Shear of layers, MPa
09G2S	320	470	0.8	1	1	310±28	170±16
09G2S	320	470	0.8	0.5	0.5	312±28	162±16
09G2S	320	470	0.6	1	1	280±28	163±16
09G2S	320	470	0.6	0.5	0.5	247±28	162±16

5. Results of research on the development of production technologies of pressure vessels

The studies allowed working out the technological process of compaction of the multilayered wall of the spherical pressure vessel. The material of the vessel is 03H11N10M2T maraging steel. Inner diameter – 0.125 m, wall thickness – $(2.4 \div 3.0) \cdot 10^{-3}$ m, (3.1; 3.0.8; 2.0.8; 2.0.8+1.1) m. The spherical bottom shall meet the following requirements:

- the maximum residual deformation shall not exceed 1 %, while the interlayer deformation shall not differ by more than 0.2 %;

- the density of the multilayered wall shall be uniform, gaps shall not exceed $0.01 \cdot 10^{-3}$ m, monolithic sections are not allowed;

- at test temperatures up to +65 °C, metal toughness shall remain at the aged values.

The required compaction of the multilayered wall is achieved by pulse action on the pre-stamped blank stack (Fig. 4). The semi-finished product was placed in a spherical cavity die on which a cylindrical micro-basin was mounted to accommodate the transfer medium.

The edges of the semi-finished product installed in the die were lubricated with sealing putty and evacuated. Then the cavity of the semi-finished product and the die was filled with the transfer medium. At the first transition, the semi-finished product was planted on the die. As a power source, the spherical explosive charge weighing $2 \cdot 10^{-3}$ kg placed in the center of the hemisphere was used. As a result of this operation, the outer layer of the stack is fully adjacent to the die surface and minor defects (corrugations, nicks, dents, etc.) that occur during drawing and transfer are eliminated. Thereafter, direct compaction of the multilayered wall of the spherical bottom was made. Cylindrical explosive charge with a detonation velocity $D = 2,500 \div 3,000$ m/s was applied. The charge was detonated from a point belonging to the lower surface of the cylinder base.

The resulting bottoms made of quasi-layered material (Fig. 4) were used to make spherical pressure vessels.

At the same time, the technological process of compaction of the three-layer wall of spherical bottoms of $\varnothing 0.480 \div 0.488$ m, material – VNS-17, thickness of each blank of 0.006 m according to the above technology was implemented. The bottoms obtained were used to make pressure vessels (Fig. 5).

As it turned out, during the vessel welding process, the stack is laminated in the weld zone. To eliminate this defect, it was proposed to perform explosion welding of the blank stack in the lamination zone. It was not possible to obtain adhesion of the layers immediately after compaction due to the lack of conditions for the acceleration of welded surfaces. To ensure adhesion of the layers, the gap shall be at least $0.5h$

(where h is layer thickness). The technological process was carried out as follows.



Fig. 4. Pre-stamped blank stack



Fig. 5. Spherical pressure vessel made of quasi-layered material

The blank stack was placed in a basin of water. At a distance $L=10 \div 15 \cdot 10^{-3}$ m from the welded surfaces, explosive charge (detonating cord) was equidistantly established and initiation was made.

This resulted in the lamination of the edges. Then the stack was placed in the die. The gap cavity was evacuated and explosion welding was performed. Only then the multilayered wall was compacted [25].

In a number of schemes of hydraulic explosion sizing, it is possible to carry out glancing collision of the multilayered packet with the die or outer layer by special profiling of the surface of the combined layer.

In this case, it is necessary to provide a constant predetermined collision angle in the stationary throwing mode.

The solution to this problem is generally formulated as follows. The set surface of the die or clad surface is described by the equation $\Phi(x_1, x_2, x_3)$. It is required to determine the shape of the blank $G(x_1, x_2, x_3)$, the throwing of which towards the given surface provides a constant angle between the tangents to the specified and desired surfaces at any point of collision. The equation of the clad surface is presented as follows:

$$x_1=x_1(u, v), x_2=x_2(u, v), x_3=x_3(u, v), \quad (1)$$

where x_1, x_2, x_3 are coordinates; u, v are surface parameters.

The square of the differential of arc on the surface (1) at the point (u, v) , expressed in the first basic quadratic form, is:

$$ds^2 = A(u, v)du^2 + 2B(u, v)du \cdot dv + C(u, v)dv^2, \quad (2)$$

where

$$A(u, v) = \left(\frac{dx_1}{du}\right)^2 + \left(\frac{dx_2}{du}\right)^2 + \left(\frac{dx_3}{du}\right)^2,$$

$$B(u, v) = \frac{dx_1}{du} \cdot \frac{dx_1}{dv} + \frac{dx_2}{du} \cdot \frac{dx_2}{dv} + \frac{dx_3}{du} \cdot \frac{dx_3}{dv},$$

$$C(u, v) = \left(\frac{dx_1}{dv}\right)^2 + \left(\frac{dx_2}{dv}\right)^2 + \left(\frac{dx_3}{dv}\right)^2.$$

The angle between two regular curves on the surface:

$$u = u_1(t), \quad v = v_1(t),$$

$$u = u_2(t), \quad v = v_2(t), \quad (3)$$

passing through the point (u, v) is determined by the formula:

$$\cos \gamma = A \frac{du_1}{ds} \cdot \frac{du_2}{ds} + B \left(\frac{du_1}{ds} \cdot \frac{dv_2}{ds} + \frac{du_2}{ds} \cdot \frac{dv_1}{ds} \right) + C \frac{dv_1}{ds} \cdot \frac{dv_2}{ds}. \quad (4)$$

With the surface of the die described by the equations $u_1(t), v_1(t)$, the surface $u_2(t), v_2(t)$ moves so that its movement along the radius vector drawn from the center of curvature to the points u, v satisfied the equation (4) with constant $\cos \gamma$.

For a spherical surface profile in polar coordinates ρ, ϕ , when the initiation point is in the center, the equation of the clad surface has the following form:

$$\rho(\phi) = (R - h) \exp(-\phi \cdot \text{tg} \gamma), \quad (5)$$

where R is the sphere radius; h is the distance between the blank and die surfaces.

If the clad surface is not analytically described, then approximating dependencies with spline functions, interpolation polynomials, etc. are used. The description of Ferguson's curves is most preferable. In this case, to find the desired profile of the clad surface, it is necessary to ensure that the derivatives coincide at the boundary points.

6. Discussion of research results and requirements for the production technology of quasi-layered composites

As a result of the studies, it was found that the quality and reliability of multilayered parts are largely determined by the state of the interlayer zone or welding zone. Strength properties are determined by design requirements and largely depend on the organization of the plastic forming process and quality of joined surfaces. The latter is widely regulated by the use of technological interlayers that have the activating or inhibiting effect on weldability.

In addition to the known requirements for explosion stamping tooling, more stringent conditions for the surface quality of the sizing die and materials for it should be added. Arithmetical mean deviation of the profile Rq is not more than $1.0\ \mu\text{m}$ and the relative reference length of the profile is not more than $0.4\ \mu\text{m}$. The material should have a higher elastic limit compared to the treated blanks. Structurally, the die should have the same rigidity over the entire surface.

The most acceptable schemes and parameters of deformation and processing are determined. The most appropriate scheme for forming explosion-welded layered blanks is the process of non-hold-down drawing with end spall elements. The parameters for combining explosion stamping and welding processes correspond to minimum values of the welding parameter and dynamic turning angle for the given composition with mandatory support of blanks with an elastic, loose or viscous medium. Production of multilayered shells with monolithic edges is more expedient to carry out by preliminary concreting of edges and subsequent forming of the blank stack.

Toughness tests showed that the ability of materials to withstand the influence of stress concentrators (cracks) after pulse loading is quite high and even 1.5–1.9 times exceeds the absorbed energy of the original aged samples. The toughness of the aged samples is $(63 \div 68) \cdot 10^{-4}\ \text{J} \cdot \text{m}^{-2}$.

Quantitative assessment of experimental data was carried out by the method of mathematical statistics in accordance with the requirements of GOST 8.207–86 «Direct measurements with multiple observations. Methods of processing the results of observations» and allowed concluding that experimental values of toughness and interlayer strength are subject to normal distribution; reproducibility of the experiment is confirmed by the Cochran test.

The most appropriate scheme for forming explosion-welded layered blanks is the process of non-hold-down drawing with end spall elements, since in this case the effect of reflected shock waves is eliminated. In addition, the interaction of shock waves arising in the blank and hold-down ring is excluded.

Toughness tests showed that the ability of materials to withstand the influence of stress concentrators (cracks) after pulse loading is quite high and even 1.5–1.9 times exceeds the absorbed energy of the original aged samples, which is explained by non-entropic deformation processes under explosive loading.

7. Conclusions

1. For the needs of the defense industry, an effective technique of compaction and sizing of layered blanks by loading with a traveling shock wave with a given interlayer strength is developed. The adhesion strength of the layers is within 0.2...0.5 of the strength of the base material. In addition, the combination of explosion welding and stamping processes allowed obtaining products with monolithic edges, which prevented lamination of the multilayered wall during welding spherical butt joints for flamethrower vessels.

2. Explosive loading led to hardening of the layer material and strength increase while maintaining ductility, so when bullets hit pressure vessels, there is no fragmentation effect on manpower and equipment in combat conditions. The resulting interlayer strength compensates for the effect of liquid explosion inside the vessel. The technology, combining the advantages of explosion welding and stamping, allowed abandoning the manufacture of pressure vessels of monolithic blanks of large thickness (hull parts of submarines and deep-sea vehicles).

Acknowledgments

The team of authors expresses deep gratitude to the staff members of the E. O. Paton Electric Welding Institute and N. E. Zhukovsky Kharkiv Aviation Institute. We are especially grateful to B. E. Paton for material support in the preparation and execution of experiments, V. K. Borisevich for assistance in organizing and implementing works on the manufacture of technological equipment, and A. U. Solomyaniy for the development of experimental complex for measuring the adhesion strength of layers, N. T. Senchuk for assistance in carrying out explosion operations, organizing and carrying out works on the manufacture of technological equipment, experimental and full-scale parts and blanks of layered composite materials. With their participation, it became possible to carry out explosion operations, mechanical tests of components of layered composite materials, develop and manufacture the complex for measuring the adhesion strength of layers when sizing layered blanks.

References

1. Dragobetskii, V., Zagirnyak, V., Shlyk, S., Shapoval, A., Naumova, O. (2019). Application of explosion treatment methods for production Items of powder materials. *Przegląd Elektrotechniczny*, 5, 39–42. doi: <https://doi.org/10.15199/48.2019.05.10>
2. Zagirnyak, M. V., Dragobetskyi, V. V. (2015). New methods of obtaining materials and structures for light armor protection. *International Conference on Military Technologies (ICMT) 2015*. doi: <https://doi.org/10.1109/miltechs.2015.7153695>
3. Zagoryansky, V. (2014). Modelling of initial thicknesses of layers at rolling of bimetallic packages on terms of joint plastic deformation. *Visnyk KrNU imeni Mykhaila Ostrohradskoho*, 4, 94–99.
4. Dragobetskii, V. V., Shapoval, A. A., Zagoryanskii, V. G. (2015). Development of elements of personal protective equipment of new generation on the basis of layered metal compositions. *Steel in Translation*, 45 (1), 33–37. doi: <https://doi.org/10.3103/s0967091215010064>
5. Markov, O., Gerasimenko, O., Aliieva, L., Shapoval, A. (2019). Development of the metal rheology model of high-temperature deformation for modeling by finite element method. *EUREKA: Physics and Engineering*, 2, 52–60. doi: <https://doi.org/10.21303/2461-4262.2019.00877>
6. Zagoryanskiy V. (2015). Justification of the suitability of the steel-aluminum bimetal by the calculating criteria of the bullet-proof armor protection. *Visnyk Natsionalnoho tekhnichnoho universytetu Ukrainy «Kyivskiy politekhnichnyi instytut»*. Seriya: Mashynobuduvannia, 3 (75), 37–41.

7. Zagoryanskiy, V. G., Zagoryanskiy, O. V. (2014). Razrabotka metodiki rascheta obzhatiy pri prokatke mnogoslownykh paketov iz vysokolegirovannykh staley. Nauchnyi vestnik Donbasskoy gosudarstvennoy mashinostroitel'noy akademii, 3, 27–32.
8. Mikhailov, O. V., Kartuzov, I. V., Kartuzov, V. V. (2018). Computer Modeling of Projectile Penetration into Hybrid Armor Panel with Regular Packing of Ceramic Discrete Elements. Ceramic Engineering and Science Proceedings, 175–181. doi: <https://doi.org/10.1002/9781119474678.ch17>
9. Kartuzov, V., Kartuzov, I., Mikhailov, O. (2017). Computer modeling of process of projectile's penetration into discrete-element armor panel. Procedia Engineering, 204, 92–99. doi: <https://doi.org/10.1016/j.proeng.2017.09.760>
10. Galanov, B. A., Kartuzov, V. V., Grigoriev, O. N., Melakh, L. M., Ivanov, S. M., Kartuzov, E. V., Swoboda, P. (2013). Penetration Resistance of B4C-CaB6 Based Light-weight Armor Materials. Procedia Engineering, 58, 328–337. doi: <https://doi.org/10.1016/j.proeng.2013.05.037>
11. Shtern, M. B., Kartuzov, E. V. (2016). Formation and Propagation of Shock Waves in Highly Porous Materials. Powder Metallurgy and Metal Ceramics, 55 (3-4), 134–140. doi: <https://doi.org/10.1007/s11106-016-9788-x>
12. Zagirnyak, M. V., Prus, V. V., Lyashenko, V. P., Miljavec, D. (2011). Structuring soft-magnetic composite materials. Informacije MIDEM, 41 (2), 86–91.
13. Gorbatyuk, S. M., Gerasimova, A. A., Belkina, N. N. (2016). Applying Thermal Coatings to Narrow Walls of the Continuous-Casting Molds. Materials Science Forum, 870, 564–567. doi: <https://doi.org/10.4028/www.scientific.net/msf.870.564>
14. Haikova, T., Puzyr, R., Dragobetsky, V., Symonova, A., Vakylenko, R. (2019). Finite-Element Model of Bimetal Billet Strain Obtaining Box-Shaped Parts by Means of Drawing. Advances in Design, Simulation and Manufacturing II, 85–94. doi: https://doi.org/10.1007/978-3-030-22365-6_9
15. Kukhar, V., Kurpe, O., Klimov, E., Balalayeva, E., Dragobetskii, V. (2018). Improvement of the Method for Calculating the Metal Temperature Loss on a Coilbox Unit at The Rolling on Hot Strip Mills. International Journal of Engineering & Technology, 7 (4.3), 35–39. doi: <https://doi.org/10.14419/ijet.v7i4.3.19548>
16. Chausov, M., Maruschak, P., Pylypenko, A., Markashova, L. (2016). Enhancing plasticity of high-strength titanium alloys VT 22 under impact-oscillatory loading. Philosophical Magazine, 97 (6), 389–399. doi: <https://doi.org/10.1080/14786435.2016.1262973>
17. Kartuzov, I. V., Bekenev, V. L., Kartuzov, V. V. (2018). Molecular-Dynamic Modeling of Propagation of Shock Wave in Porous Ceramic Materials. Ceramic Engineering and Science Proceedings, 159–163. doi: <https://doi.org/10.1002/9781119474678.ch15>
18. Kukhar, V., Prysiashnyi, A., Balalayeva, E., Anishchenko, O. (2017). Designing of induction heaters for the edges of pre-rolled wide ultrafine sheets and strips correlated with the chilling end-effect. 2017 International Conference on Modern Electrical and Energy Systems (MEES). doi: <https://doi.org/10.1109/mees.2017.8248945>
19. Zakharov, A. N., Gorbatyuk, S. M., Borisevich, V. G. (2008). Modernizing a press for making refractories. Metallurgist, 52 (7-8), 420–423. doi: <https://doi.org/10.1007/s11015-008-9072-5>
20. Lupkin, B. V., Mamlyuk, O. V., Pinchuk, A. A. (2017). Efficiency of Application of Superficial Deformation is in Aircraft Building. Otkrytye informatsionnye i komp'yuternye integrirovannye tehnologii, 75, 79–91.
21. Paton, B. E., Chepurnoj, A. D., Saenko, V. Ya., Medovar, L. B. (2004). Prospects of production of welded thick-walled bimetal bodies of high-pressure vessels. Avtomaticheskaya Svarka, 1, 30–39.
22. Paton, B. E., Chepurnoj, A. D., Saenko, V. Ya., Medovar, L. B., Litvinenko, A. V. (2004). Prospects of application of electroslag technologies in production of high-pressure vessels. Advances in Electrometallurgy, 1, 2–9.
23. Tkachov, R. O., Kukhar, V. V., Klimov, E. S., Prysiashnyi, A. H. (2019). Development and Application of Tube End Forming Process with Combined Swaging and Local Differential Pre-Heating. Materials Science Forum, 946, 755–760. doi: <https://doi.org/10.4028/www.scientific.net/msf.946.755>
24. Puzyr, R., Haikova, T., Trotsko, O., Argat, R. (2016). Determining experimentally the stress-strained state in the radial rotary method of obtaining wheels rims. Eastern-European Journal of Enterprise Technologies, 4 (1 (82)), 52–60. doi: <https://doi.org/10.15587/1729-4061.2016.76225>
25. Barabash, A. V., Gavril'chenko, E. Y., Gribkov, E. P., Markov, O. E. (2014). Straightening of sheet with correction of waviness. Steel in Translation, 44 (12), 916–920. doi: <https://doi.org/10.3103/s096709121412002x>