

UDC 622.24.05 (031)

DOI: 10.15587/1729-4061.2019.184939

DEVELOPMENT OF A RESOURCE-SAVING, SMALL-SIZED DOWNHOLE HYDRAULIC MACHINE FOR WELL DRILLING

T. Mendebaev

Doctor of Technical Sciences, Honored Worker of Kazakhstan and Russia, Chief Researcher*

E-mail: nvc_almas@mail.ru

N. Smashov

PhD, Director*

E-mail: nur_cm@mail.ru

H. Ismailov

President**

E-mail: zaocgs@citylink.kz

B. Izakov

Chief Engineer**

E-mail: zaocgs@citylink.kz

*ALMAS Research and Development Center

Limited Liability Partnership

Abay ave., 153, Almaty,

Republic of Kazakhstan, 050009

**Limited Liability Partnership

«Centrgeolsemka»

Svobodny lane, 9, Karaganda,

Republic of Kazakhstan, 100019

Аналізом структурних особливостей і технологічних можливостей серійних забійних гідродвигунів (гідромашин), призначених для буріння свердловин, встановлені їх недоліки. Це обмежені ресурси, обумовлені складністю конструкції, витрата робочої рідини, значні габаритні розміри по довжині, маса, низькі частоти обертання валу, що не відповідають технологічним режимам алмазного буріння свердловин. З аналізу конструктивних схем забійних гідродвигунів зроблено висновок, що найбільші можливості для максимального використання потенційної енергії робочої рідини мають гідромашини роторного типу.

Як об'єкт дослідження була запропонована конструктивна схема гідромашини, в якій використані фізичні принципи перетворення ваги (енергії) стовпа робочої рідини в момент обертання статора навкрузи ротора, що не обертється. Враховані принципи розподілу у напрямку руху потоку, що набігає, від зворотного, що розтікається, виключення застійної зони і створення багаторівневого моменту реактивних сил витікання рідини.

За розробленою методикою виконані теоретичні розрахунки енергетичних характеристик двокамерної глибинної гідромашини, визначені технічні дані, наведена розрахункова схема силової взаємодії робочої рідини з елементами гідромашини.

На підставі результатів теоретичних обчислень була розроблена конструкторсько-технологічна документація забійної гідромашини, виготовлено дослідний зразок, проведені експерименти для виявлення працездатності схеми, граничних значень її працездатності. Кількісні значення її енергетичних характеристик визначені за показаннями контрольно-вимірвальних приладів.

Зроблено порівняльний аналіз технічних і енергетичних характеристик забійної гідромашини роторного типу з серійно випускаючими серійними гідродвигунами, турбобуром ТГ-124 і гвинтовим двигуном Д1-124 однакового діаметра.

Запропоновано умови застосування забійної гідромашини, перспективні напрямки подальших наукових досліджень і дослідно-конструкторських розробок щодо її вдосконалення і розширення сфери застосування

Ключові слова: статор, ротор, робоча рідина, момент обертання, буріння свердловин

Received date 02.10.2019

Accepted date 12.11.2019

Published date 10.12.2019

Copyright © 2019, T. Mendebaev, N. Smashov, H. Ismailov, B. Izakov

This is an open access article under the CC BY license

(<http://creativecommons.org/licenses/by/4.0>)

1. Introduction

Drilling wells is a highly informative, productive way to study the depths of the earth. The irreversible global tendency to increase the depth of wells, the extension of scope of their application, is accompanied by the need to resolve issues related to the depth and purpose of wells.

The main problems include resource conservation, reducing the metal and energy intensity of a drilling process, creating downhole conditions corresponding to the technological modes of rock-destroying tool operation.

Among the well drilling tools, in terms of the possibilities for reducing labor-intensity of operations and ensuring safety, the most appropriate for the conditions of the depth of their drilling are the downhole hydraulic engines – the screw, turbine, and rotary type. Their distinctive feature is the supply of energy to a rock-destroying tool without the rotation of a drill column.

In addition to reducing energy costs, the factors that stimulate the work on the creation and improvement of the structure of downhole hydraulic machines are to solve the tasks on drilling multi-downhole wells with sidetracks along the strike of the ore horizon.

This would require the downhole hydraulic machines that are small in length, with low consumption of a working liquid, resource-saving, and with energy characteristics corresponding to the conditions of diamond drilling of wells.

2. Literature review and problem statement

Paper [1] notes that modern drilling technologies of multi-downhole, directed wells require the use of downhole hydraulic machines no longer than 10–15 meters. The requirement is met by the hydro-turbine downhole engines produced by the American companies Neyrfor (Shlumberger)

and Turbo Power (Halliburton). Their main drawbacks are the metal consumption and the consumption of a working fluid.

The main fields of research in improving downhole hydraulic machines are the modernization of existing downhole screw engines in order to increase operational resources and the development of new reliable geared turbo-drills with capabilities to eliminate rotor vibrations and reduce the size of the engine [2].

There are known studies [3] into the negative effects of vibration on the service life of a downhole engine and the economic aspects of drilling. They state that new hydraulic drives are needed to eliminate rotor vibrations and reduce engine dimensions. To this end, it is proposed to use a hydraulic hybrid system, which combines the best characteristics of the propeller – a motor and a motor with a roller blade.

In addition to vibration, drilling solutions [4] containing particulate matter also exert a significant impact on the shortening of the service life of the engine.

In addition, the service life of a screw downhole engine is significantly affected by the turbulence of the flow near the points of contact «rotor-stator» and between them, which is confirmed by endoscopic justifications [5].

Analysis of scientific works has revealed the absence of a simple and effective solution to the problem of rotor vibration. There is a study [6], based on the concept that each screw surface can be replaced with a set of flat and cylindrical surfaces. According to the authors, this solution could reduce the level of rotor fluctuations.

Paper [7] outlines basic principles of the development of a high-momentum modular engine. The results from theoretical and experimental studies show that the developed downhole engine is characterized by lower twisting fluctuations, improved stability of work and restored energy characteristics of a gerotor machine.

However, it is technically impossible to completely eliminate the vibration of the rotor of screw downhole engines and turbo-drills due to the rotation of the rotor in the stator cavity.

The structure of screw downhole engines includes a complex mechanism of dynamics of interaction between the stator and the rotor. Study [8] has established that the maximum contact pressure of 0.78 MPa occurs in the places of contact between the stator's groove and the rotor tooth. Study [9] found the phenomenon of self-heating of a rubber coating up to 123 °C, which is caused by a cyclical load when the rotor rotates in the rubber coating of the stator elastomer.

The simulation of stator heating due to the phenomenon of hysteresis in the elastomer is described in work [10]. In this case, forecasts from the models are compared with empirical data; there are no noticeable discrepancies between them.

Paper [11] reports results from a stator heating simulation, namely, a set of modules was designed with a unique device that helps create cross-links between them. This, according to the authors, makes it possible to predict the fatigue strength of power sections, including elastomers.

Elastomers with high elastic properties complicate the design, and actually determine the service life of the stator and the entire downhole hydraulic machine.

Another significant drawback of screw downhole engines that limits the scope of their application is the low rotational frequencies of the rotor, between 200 and 450 rpm, which are permissible when drilling wells using the PDC bits.

Given the increasing depth of well drilling in the world, especially in offshore fields, the volume of application of impregnated diamond bits is growing. When used, the mecha-

tics of rock destruction differ significantly from the cutting effect of the PDC bits with polycrystalline diamond-solid cutters and crushing-chipping by three-cone bits. Effective operation of an impregnated diamond bit with a continuous drilling of wells and ring crowns with core selection is possible at the rotation rate of tools from 500 to 1,000 rpm.

According to data from [12], there is currently a technology for the development of reliable, high torque engines (turbodrills) that work with cone bits at a rotation speed of 150–250 rpm and diamond bits at a rotation rate of 400–800 rpm over periods of 100 to 200 hours.

Hence the conclusion that the main drawback of high speed turbodrills is a small operational resource.

Judging by the content of scientific research and development, related to solving the problems of improving downhole hydraulic motors, it follows that their shortcomings are typical of the scheme «a rotating rotor inside the stator». Namely: the presence of a significant contact area between the rotor and stator with a rubberized elastomer, transmission of rotor vibration to the stator, friction, wear, complexity of design, shortening of service life. Also included are the low energy characteristics of hydraulic motors in terms of the amount of a working fluid being supplied, lengthening in size, metal consumption, and maintenance costs. Therefore, a conceptual basis for the creation of downhole hydraulic motors, corresponding to the realities of modern well drilling, could be the basic solutions that exclude the conditions for the emergence of specified shortcomings, thereby making it possible to apply physical principles for new purposes.

In this regard, in terms of design and technological capabilities, rotary-type downhole hydraulic machines are the most attractive. The sources of information provide scarce information about the practical application of rotary-type hydraulic machines in well drilling.

The successful experience of drilling with air blowing of a large diameter well, using as a downhole engine the two paired serial rotational pneumatic motors, is known in the USA. Rather rarely used are the rotor layouts and specially designed PDC bits, produced by the American companies Baker Hughes, Halliburton, and Schlumberger. The disadvantages are the complexity of the design, the high cost of maintenance, comparable in price to rocket and space equipment [13].

The first sample of a rotary hydraulic machine with blades was tested in the Federal Republic of Germany. However, it did not work well enough due to the low durability of components. Later, it was proposed in the U.S. to use a more advanced engine of the same type «Momo-Drill»; it was not, however, applied thereafter.

3. The aim and objectives of the study

The aim of this study is to develop a resource-saving, small-sized, two-chamber downhole hydraulic machine of the rotary type for drilling wells.

To accomplish the aim, the following tasks have been set:

- based on analysis of the structure and working conditions of downhole hydraulic motors, form a structural scheme of a two-chamber rotary-type downhole hydraulic machine based on the principle «a rotating stator around the non-rotating rotor»;
- by substantiating the operation principle of the structural scheme, define the estimated technical and energy

characteristics for a two-chamber rotary-type hydraulic machine depending on the consumption of a working fluid;
 – to conduct a comparative analysis of the results from studies of qualitative and quantitative characteristics of a two-chamber downhole hydraulic machine with similar indicators for standard downhole hydraulic motors.

4. Materials and methods to study the operation and interaction between a working fluid and the elements of a two-chamber downhole hydraulic machine

The object for a detailed study is the constructed scheme of a two-chamber downhole hydraulic machine [14, 15], which employs physical principles not previously found in their designs.

Fig. 1 shows a general view of the two-chamber downhole hydraulic machine of rotary type; Fig. 2, 3 demonstrate, respectively, the A-A and B-B cross-sections from Fig. 1.

The hydraulic machine includes a stator consisting of upper 1 and bottom 2 parts connected to each other, and, through bearing nodes 3 and 4, around rotor 5.

The inner surface of upper 1 part of the stator hosts fixed semi-cylindrical blades 6 along rim 7, forming a ring cavity. The latter hosts circular grooves 8 with a bottom and holes 9, attached to the outer side of semi-cylindrical blades 6, oriented to the middle regions of the inner surfaces of oncoming blades 6.

In this case, there are gaps between the side walls of circular grooves 8 on one side with the inner surface of upper part 1 of the stator, on the other – along rim 7.

Upper part 1 of the stator has peripheral holes 10 for the reactive flow of a working liquid from the ring cavity into a space behind the pipe. Rim 7 has side holes 11, connecting a ring cavity to gap 12 between the rim and rotor 5.

Note that the upper level of circular grooves 8 is above peripheral 10 and side 11 holes. Rotor 5 has sloping channels 13 in the direction of stator rotation, oriented to the bottom of circular grooves 8. Bottom part 2 of the stators has treaded horizontal grooves 14 (Fig. 3), originating from gap 12 and coming out into the space behind pipes by smoothly overturning the overtaking-axial line of the stator.

The head flow of an incident working liquid at speed ϑ_0 and flow rate Q_0 , along sloping channel 13 in rotor 5, at acute angle α to the horizontal line enters the bottom of circular grooves 8 in upper part 1 of the stator in the direction of its rotation. Under the action of the ejecting, directed force of the weight of the column of a working liquid, by subsequent pressure from the flow of a flowing fluid (ϑ_1, Q_1) on the inner surfaces of semi-cylindrical blades 6 on rim 7, there is a starting momentum that sets the hydraulic machine to operation. Next, the force of the reactive flow of the separated part of the working fluid $Q_1/2$ through peripheral holes 10 to the space behind pipes, creates a cumulative momentum, thereby inducing rotation of the stator on bearing nodes 3 and 4 around rotor 5.

The flowing flow of a working fluid (ϑ_2, Q_2) in the direction, reverse to the rotation of the stator, merges, through holes 9 in circular grooves 8, with a part of the flow $Q_1/2$ reflected from semi-cylindrical blades 6. Then, through side holes 11, it flows into gap 12 between rim 7 and rotor 5.

The newly formed flow $Q_2 + Q_1/2$, through horizontal grooves 14 at the stator's bottom part 2, enters, in a smooth turn, the space behind pipes in the direction opposite to the stator rotation. This creates an additional momentum of stator rotation due to the force from the reactive outflow of the working fluid.

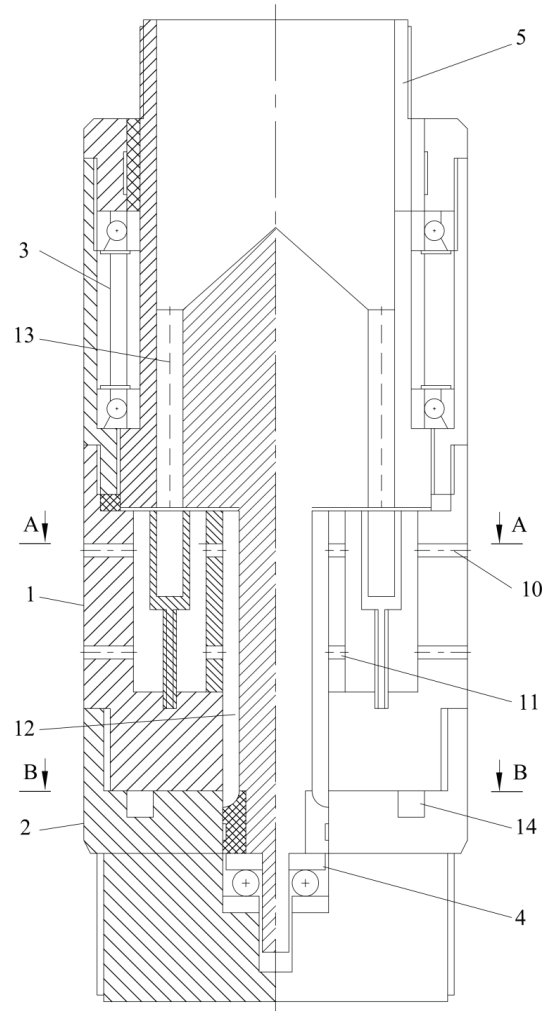

Fig. 1. General view of a two-chamber rotary-type downhole machine

Calculation of the energy characteristics of force interaction between the flow of a working fluid and elements of the downhole hydraulic machine was performed based on the Euler integral theorem and the law of preserving the amount of fluid movement.

Let us project the forces of a working fluid flow onto the OX and OY axes (Fig. 2):

$$\begin{cases} P_0 \cdot \cos \alpha = P_1 - P_2, \\ P_0 \cdot \sin \alpha + R = 0, \end{cases} \quad (1)$$

where $P_0 = \rho \cdot Q_0 \cdot \vartheta_0$; $P_1 = \rho \cdot Q_1 \cdot \vartheta_1$; $P_2 = \rho \cdot Q_2 \cdot \vartheta_2$.

Taking into consideration and assuming that the flow rate does not change ($\vartheta_0 = \vartheta_1 = \vartheta_2$):

$$\begin{cases} \rho \cdot Q_0 \cdot \vartheta_0 \cdot \cos \alpha = \rho \cdot Q_1 \cdot \vartheta_0 - \rho \cdot Q_2 \cdot \vartheta_0, \\ \rho \cdot Q_0 \cdot \vartheta_0 \cdot \sin \alpha + R = 0 \end{cases} = \begin{cases} Q_1 \cdot \cos \alpha = Q_1 - Q_2, \\ R = -\rho \cdot Q_0 \cdot \vartheta_0 \cdot \sin \alpha, \end{cases} \quad (2)$$

where R is the reaction from the bottom of the circular channel, opposite directed, but equal in magnitude to $R = -P$; ϑ_0 – is the flow rate of the incoming fluid; Q_0, Q_1, Q_2 are the fluid flow rates.

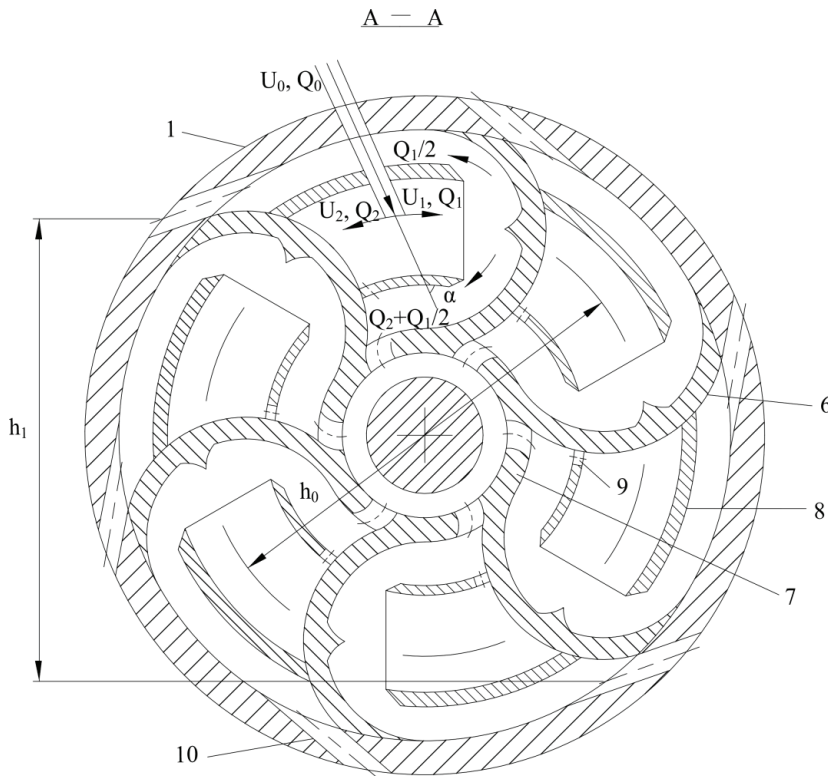

Fig. 2. Cross-section of working bodies of the stator's upper part in a two-chamber rotary-type downhole machine

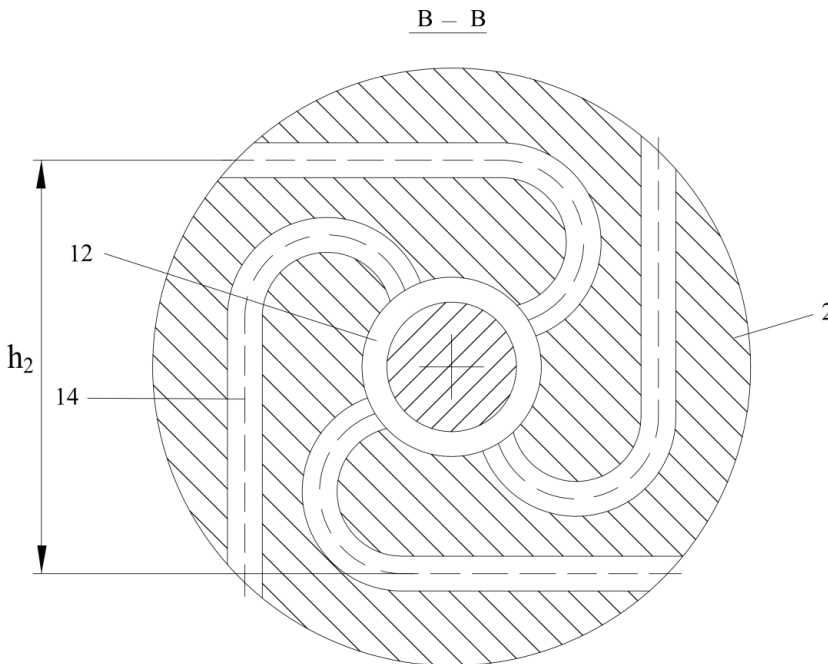

Fig. 3. Cross-section of working bodies of the stator's lower part in a two-chamber rotary-type downhole machine

It is known that $Q_0 = Q_1 + Q_2$. We shall then build and solve the system of equations with two unknowns at angle $\alpha = 45^\circ$:

$$\begin{cases} Q_0 = Q_1 + Q_2, \\ Q_0 \cdot \cos \alpha = Q_1 - Q_2 \end{cases} = \begin{cases} Q_1 = \frac{Q_0}{2} \cdot (1 + \cos \alpha), \\ Q_2 = \frac{Q_0}{2} \cdot (1 - \cos \alpha), \end{cases} \quad (3)$$

The flow rate of the incoming fluid, depending on the well depth, can be recorded in the form:

$$\vartheta_0 = \sqrt{2 \cdot g \cdot H}. \quad (4)$$

The action force of the flow on the bottom of a circular channel takes the form:

$$P_0 = \rho \cdot Q_0 \cdot \vartheta_0 \cdot \sin \alpha. \quad (5)$$

Most of the spreading flow (Q_1) acts on the blade with a curved surface, symmetrical relative to the axis of motion. By executing a blade in the form of a curvilinear surface, which has the shape of a semi-sphere, whose geometric shape does predetermine the turn of a fluid flow at angle 180° , one can obtain a double dynamic impact:

$$P_1 = 2 \cdot \rho \cdot Q_1 \cdot \vartheta_1. \quad (6)$$

To exploit the kinetic energy of a fluid flow, it is necessary to make the blades move in the direction of the flow. In this case, a fluid flow, when hitting the alternating blades, causes them to rotate. The speed of a fluid flow climbing a blade will equal:

$$\vartheta_1 = \vartheta_0 - \vartheta_{bl}, \quad (7)$$

where

$$\vartheta_{bl} = \frac{\pi \cdot D \cdot n}{1,000 \cdot 60}$$

is the velocity of a blade (D – diameter of the stator, $n=800$ rpm).

In this case, the estimated energy characteristics of a rotary hydraulic machine should strive to comply with the conditions according to which, if the blades' peripheral speed (ϑ_{bl}) is equal to half the speed of a climbing flow (ϑ_1), the stator receives maximum power from the flow.

Considering (3) and (7), expression (6) takes the form:

$$P_1 = 2 \cdot \rho \cdot \frac{Q_0}{2} \cdot (1 + \cos \alpha) \cdot (\vartheta_0 - \vartheta_{bl}). \quad (8)$$

The momentum of force of a flow action on the bottom of circular grooves is transformed into torque:

$$M_0 = P_0 \cdot h_0, \quad (9)$$

where h_0 is the distance between the middle lines of circular grooves and blades. The torque of a rotating blade is:

$$M_1 = P_1 \cdot h_0. \quad (10)$$

Momentum from the reactive fluid outflow through the peripheral holes of the stator's upper part is:

$$M_2 = P_1/2 \cdot h_1, \tag{11}$$

where h_1 is the distance between the opposite peripheral holes of the stator's upper part.

The rest of the flow (Q_2) and the half of the flow ($Q_1/2$), acting on the blade with a curvilinear surface, enter the gap between a rim and the rotor:

$$P_2 = \rho \cdot (Q_2 + Q_1/2) \cdot \vartheta_0, \tag{12}$$

where

$$Q_1 = \frac{Q_0}{2} \cdot (1 + \cos \alpha);$$

$$Q_2 = \frac{Q_0}{2} \cdot (1 - \cos \alpha).$$

Momentum from the reactive fluid outflow through a channel in the bottom part is:

$$M_3 = P_2 \cdot h_2, \tag{13}$$

where h_2 is the distance between opposite grooves of the bottom part.

The total momentum, taking into consideration the number of sections in a hydraulic machine, is:

$$\Sigma M = (M_0 + M_1 + M_2 + M_3) \cdot m, \tag{14}$$

where m is the number of sections in a rotary hydraulic machine.

The theoretical efficiency of a downhole hydraulic machine is determined from expression:

$$\eta = 2 \cdot \left(1 - \frac{\vartheta_{bl}}{\vartheta_1}\right) \cdot \frac{\vartheta_{bl}}{\vartheta_1} \cdot (1 + \cos \beta), \tag{15}$$

where $\beta = 20^\circ$ is the angle of the jet reflected from a blade.

5. Results from studying the qualitative and quantitative characteristics of a two-chamber rotary-type downhole hydraulic machine

According to our calculation procedure, we determined the technical and energy characteristics of a two-chamber rotary-type downhole hydraulic machine relative to the stator's external diameter of 122 mm.

Fig. 4 shows the dynamics of change in the energy characteristics of a two-chamber downhole hydraulic machine depending on the values of a working fluid flow rate and the depth of well drilling.

Below are the estimated values of the technical and energy characteristics (confirmed experimentally) for a two-chamber rotary-type downhole hydraulic machine in comparison with standard downhole hydraulic engines (screw, turbodrills) (Table 1).

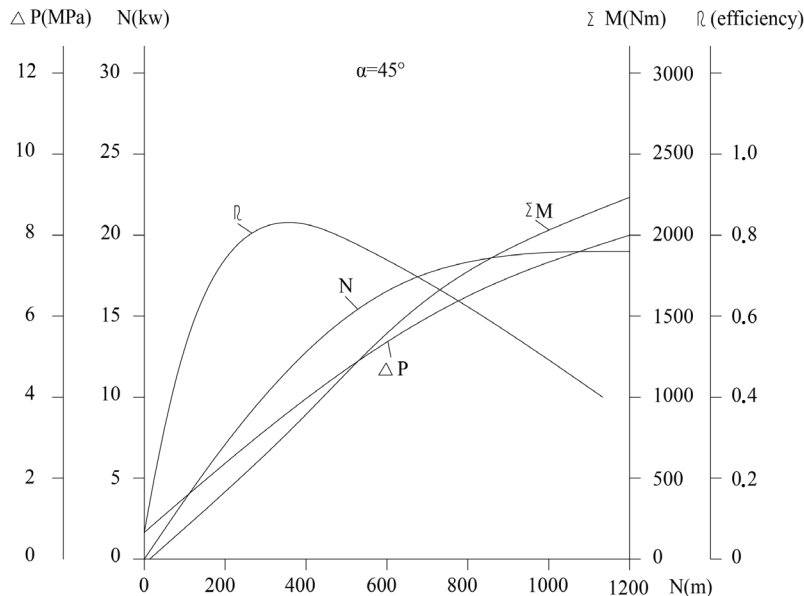

Fig. 4. Energy characteristics of a two-chamber downhole rotary-type hydraulic machine with the stator's diameter of 122 mm, the fluid flow rate $Q = 120$ l/min, depending on wells' depth $H(m)$

Table 1

Estimated values of technical and energy characteristics for a rotary-type downhole hydraulic machine compared to standard hydraulic engines

Dimensions	Technical			Energy			
	Diameter, mm	Assembled length, mm	Mass, kg	Working fluid flow rate, l/sec	Pressure differential, MPa	Force momentum on shaft, N·m	Power, kW
Rotary-type downhole hydraulic machine	122	550	40	2...5	6.0...8.0	2,000...2300	18...20
Turbodrill TG-124	124	9,160–12,940	930–1,330	12	8.9–9.3	450–470	–
Screw D1-127	127	5,545	387	15...20	6.5...8.7	2,200...3,000	30...50

The results from calculations of the technical and energy characteristics of a two-chamber rotary-type downhole hydraulic machine formed the basis for the development of structural-technological documentation for the experimental model of a hydraulic machine. It was manufactured and tested under industrial conditions at well drilling (Fig. 5).



Fig. 5. Rotary-type downhole hydraulic machine with the stator's diameter of 122 mm

This has allowed us to confirm an argument that the structural scheme for a two-chamber downhole hydraulic machine is feasible; subject to improving, it could become an effective means for building deep wells, especially multi-downhole ones.

6. Discussion of results from developing and investigating the characteristics of a two-chamber downhole rotary-type hydraulic machine

The results obtained are due to a feature in the structural scheme for a two-chamber downhole hydraulic machine of the rotary type «a rotating stator around the rotor» that excludes the direct contact between them. That, in the absence of a contact friction surface, reduces wear, hence the increase in operational resources, simplification of the design and a reduction of power loss by the hydraulic machine. Therefore, there is an opportunity to significantly reduce the consumption of a working fluid.

In this case, the possible vibration on the stator is damped by the walls of wells.

The scheme implies the conversion of the directed, ejecting force of weight (energy) of a working fluid at the time of stator rotation, the elimination of stagnant zones at fluid motion, and the scattering of a flow nucleus in the feed system.

In addition, this scheme exploits such physical principles such as a shoulder of force momenta, a multi-level momentum

from the reactive outflow of a working fluid, which is not inherent in the existing designs of downhole hydraulic motors.

Taken together, features in the structural scheme of a rotary-type two-chamber downhole hydraulic machine maximize the use of potential energy of the working fluid by achieving high energy characteristics for the volume of feed and a small length of the hydraulic machine.

It should be noted that increasing a well depth is accompanied by a growth of energy costs. In a given case, considering that increasing the depth of wells increases the weight of a working fluid column, the negative factor of depth becomes positive. The limiting factor for using a two-chamber rotary-type downhole hydraulic machine at well drilling may be the need to apply a working fluid without sludge and other solid impurities.

Based on experiments, the most vulnerable node in the structure of a hydraulic machine is the bearing nodes, because of the inability to add oil to them for lubrication. This shortens their lifespan.

However, a solution to this problem may be the use, in the structure of a hydraulic machine, of plain bearings made from plastics, which operate better in water than in oil.

Downhole hydraulic motors are mainly used in drilling wells for oil and gas, less often for groundwater. A direction for advancing this study is the development of a two-chamber rotary-type downhole hydraulic machine for drilling small diameter wells (76 and 95.6 mm) with core sampling for exploration of solid mineral deposits. If this task is successfully resolved, the scope of application of downhole hydraulic motors would expand significantly.

7. Conclusions

1. We have constructed a workable scheme of a two-chamber rotary-type downhole hydraulic machine, whose structural features «a rotating stator around the rotor» make it possible to exploit physical principles for a new purpose.

2. Calculations for determining the values of technical and energy characteristics were performed for a two-chamber rotary-type downhole hydraulic machine with a stator's diameter of 122 mm.

Specifications: assembled length is 550 mm; weight is 40 kg.

Energy characteristics: a working fluid flow rate is in the range of 2–5 l/s, pressure differential is 6.0–8.0 MPa, a force momentum on the stator is 2,000–2,300 N·m, power is 18–20 kW.

3. We have performed a comparative analysis of the estimated characteristics for a two-chamber downhole hydraulic machine with standard downhole hydraulic motors, the turbodrill TG-124 and the screw engine D1-127. It has revealed that at the lengths and mass that are orders of magnitude less, and a noticeably lower consumption of a working fluid at a high frequency of stator rotation (based on experiment, 700–800 rpm), a two-chamber downhole hydraulic machine is, in terms of the torque magnitude, is close to the indicators for a screw hydraulic engine and significantly outperforms a turbodrill.

References

1. Simonyants, S. L., Mnatsakanov, I. V. (2013). Aktual'noe napravlenie modernizatsii turbinogo sposoba bureniya. *Nefteservis*, 2, 48–50.
2. Sazonov, I. A., Mokhov, M. A., Demidova, A. A. (2016). Development of Small Hydraulic Downhole Motors for Well Drilling Applications. *American Journal of Applied Sciences*, 13 (10), 1053–1059. doi: <https://doi.org/10.3844/ajassp.2016.1053.1059>

3. Delpassand, M. S. (1999). Stator Life of a Positive Displacement Downhole Drilling Motor. *Journal of Energy Resources Technology*, 121 (2), 110–116. doi: <https://doi.org/10.1115/1.2795065>
4. Epikhin, A. V., Ushakov, A. V., Barztaikin, V. V., Melnikov, V. V., Ulyanova, S. (2015). Experimental research of drilling mud influence on mud motor mechanical rubber components. *IOP Conference Series: Earth and Environmental Science*, 27, 012051. doi: <https://doi.org/10.1088/1755-1315/27/1/012051>
5. Biletsky, V., Vitryk, V., Mishchuk, Y., Fyk, M., Dzhus, A., Kovalchuk, J. et. al. (2018). Examining the current of drilling mud in a power section of the screw downhole motor. *Eastern-European Journal of Enterprise Technologies*, 2 (5 (92)), 41–47. doi: <https://doi.org/10.15587/1729-4061.2018.126230>
6. Sazonov, Y. A., Mokhov, M. A., Frankov, M. A., Ivanov, D. Y. (2017). The research of experimental downhole motor for well drilling using PDC type drill bits. *Neftyanoe Khozyaystvo – Oil Industry*, 10, 70–74. doi: <https://doi.org/10.24887/0028-2448-2017-10-70-74>
7. Syzrantseva, K., Syzrantsev, V., Dvoynikov, M. (2017). Designing a High Resistant, High-torque Downhole Drilling Motor (Research note). *Ije transactions a: Basics*, 30 (10), 1615–1621. Available at: http://www.ije.ir/article_73045_54733bfd008797ffa0fc098077b62dbe.pdf
8. Ismakov, R. A., Zakirov, N. N., Al'-Suhili, M. H., Toropov, E. S. (2015). Issledovanie raboty pary «elastomer-metal» silovoy sektsii vintovogo zaboyного dvigatelya. *Sovremennyye problemy nauki i obrazovaniya*, 2.
9. Andoskin, V., Vyguzov, A., Kuznetsov, A., Khairullin, D., Novikov, R. (2014). Radius-Service Downhole Drilling Motors. *Burenie i neft'*, 11, 50–53.
10. Ba, S., Pushkarev, M., Kolyshkin, A., Song, L., Yin, L. L. (2016). Positive Displacement Motor Modeling: Skyrocketing the Way We Design, Select, and Operate Mud Motors. *Abu Dhabi International Petroleum Exhibition & Conference*. doi: <https://doi.org/10.2118/183298-ms>
11. Ba, S., Pushkarev, M., Kolyshkin, A., Song, L., Yin, L. L. (2016). Positive Displacement Motor Modeling: Skyrocketing the Way We Design, Select, and Operate Mud Motors. *Abu Dhabi International Petroleum Exhibition & Conference*. doi: <https://doi.org/10.2118/183298-ms>
12. Maurer, W. C., McDonald, W. J., Nixon, J. D., Matson, L. W. (1977). Downhole drilling motors: technical review. Final report. doi: <https://doi.org/10.2172/7282763>
13. Mokaramian, A., Rasouli, V., Cavanough, G. (2013). Coiled Tube Turbodrilling: a proposed technology to optimise drilling deep hard rocks for mineral exploration. *International Journal of Mining and Mineral Engineering*, 4 (3), 224. doi: <https://doi.org/10.1504/ijmme.2013.053171>
14. Mendebaev, T. N. (2018) Pat. No. 33043 Respubliki Kazahstan. Obemniy zaboyный dvigatel'.
15. Mendebaev, T. N. (2019). Pat. No. 2698336 RF. Sposob bureniya skvazhin.
16. Shashin, V. M. (1990). *Gidromehanika*. Moscow: Vysshaya shkola, 384.