

UDC 004.8

DOI: 10.15587/1729-4061.2020.195785

Розроблена та досліджена система автоматичного керування печено випалювання вуглецевих виробів з мінімізацією ймовірності дефектів на базі штучних нейронних мереж, яка відрізняється від відомих на сьогоднішній день систем можливістю обрання способу керування процесом випалювання відповідно до початкових умов та цілей ведення процесу.

Для процесу випалювання вуглецевих виробів до таких цілей можна віднести отримання продукції з мінімальною кількістю дефектних структур або безпечне скорочення тривалості технологічного процесу з метою економії енергоресурсів.

Для мінімізації кількості дефектних структур готових виробів пропонується прогнозувати ймовірність наявності дефекту у виробі, а для скорочення тривалості технологічного процесу як показник готовності продукції використовувати ентропію. Розв'язання поставлених задач базується на використанні штучних нейронних мереж з їх здатністю до узагальнення даних, а саме різних значень ймовірності наявності дефекту за різних температурних полів печі випалювання при різних регламентах роботи.

Проблема обмеженої кількості даних, необхідних для навчання штучної нейронної мережі, вирішується шляхом застосування особливої структури штучних нейронних мереж – автоенкодера.

Розроблена системи керування має ряд переваг в порівнянні з існуючими на сьогоднішній день системами. Наприклад, надає можливість вибору кроку спуску, що визначає точність траєкторії оптимального спуску, а тому і точність керування в цілому. Вибір критерію спуску робить розроблену систему гнучкою при використанні в різних умовах та при різних задачах керування. У разі аварійного переривання технологічного процесу випалювання дана система дає змогу в будь-який момент часу спланувати подальший його перебіг, забезпечивши ефективно продовження кампанії випалювання, а тому запобігає невиправданім витратам. Алгоритм керування, що використовується у системі, дозволяє прогнозувати час ведення кампанії випалювання та значення витрат палива, а відтак спрогнозувати економічну ефективність технологічного процесу.

Для оцінювання ефективності запропонованої системи автоматичного керування процесом випалювання проведено експериментальне дослідження роботи розробленої системи в порівнянні з існуючою системою керування на базі ПІД-регулятора.

Результати дослідження засвідчили, що використання нової системи керування дозволяє знизити споживання палива на 3–4 м³/год. Крім того, зменшується приріст температури заготовок в процесі обробки, що позитивно впливає на якість готової продукції

Ключові слова: процес випалювання, штучні нейронні мережі, автоенкодер, система керування з прогнозуванням, імітаційне моделювання

A SYSTEM OF AUTOMATED CONTROL FOR THE BAKING PROCESS THAT MINIMIZES THE PROBABILITY OF DEFECTS

A. Korotynskyi
Postgraduate Student*

E-mail: ihfantkor@gmail.com

O. Zhuchenko

Doctor of Technical Sciences,
Associate Professor*

E-mail: azhuch@ukr.net

*Department of Automation of

Chemical Productions

National Technical University of

Ukraine "Igor Sikorsky Kyiv

Polytechnic Institute"

Peremohy ave., 37, Kyiv,

Ukraine, 03056

Received date 14.01.2020

Accepted date 17.02.2020

Published date 28.02.2020

Copyright © 2020, A. Korotynskyi, O. Zhuchenko

This is an open access article under the CC BY license

(<http://creativecommons.org/licenses/by/4.0>)

1. Introduction

The baking process is an extremely complicated technological process of the thermal treatment of articles with great energy consumption. The two main components of energy consumption are the long duration of the process and the high product rejection rate. Reducing at least one of the cost components leads to substantial savings and makes the finished products cheaper.

Starting from the 1950s, the baking process procedure has remained almost changed and implies the heating of blanks under existing regulations.

That is why it is still a relevant task to improve the efficiency of a given process, which could be achieved by introducing a modern automated system to control this process. Despite numerous attempts to automate the operation of multi-chamber ring baking furnaces, no effective control system has been implemented for this process up

to now [1, 2]. Therefore, the analysis of actual control systems is an important step preceding the development of a control system that would meet modern requirements.

2. Literature review and problem statement

As reported in paper [3], two diffusion burners installed in vaulted chambers enabled, at a gas pressure of 3,000 Pa, to conduct the process of baking in line with the predefined schedule with accuracy $-50...+30$ °C. It is obvious that in addition to the low accuracy of the schedule of blanks baking, such a control technique led to the unjustified high overconsumption of fuel and significant defects because of a rather large temperature difference for the height of the chamber.

Given the impossibility of adjusting the air/gas ratio because of the furnace design, work [4] theoretically sub-

stantiated the use of a pulse fuel combustion system. The application of the proposed system for multi-chamber baking furnaces leads to a decrease in fuel overconsumption. The authors of [4] argue that the shortcomings in the use of rarefaction as the main parameter of air feed control give rise to the issue of air suction, namely: the increasing rarefaction leads to an increase in the amount of air supplied through the gas tract with a decrease in air suction. This, in turn, negatively affects the indicators of the process, because the increasingly cold air suction increases its influence on the temperature fields. In addition, the increase in the amount of air in a furnace chamber leads to the gas overconsumption by 30–40 % of the theoretical value per ton of baked products. It follows from work [4] that the proposed system makes it possible to reduce fuel overconsumption due to excess air impregnation through the vault of the furnace by 12–15 %. Based on the results of the tests carried out, the implementation of a given procedure provides for the saving of gas by not less than 7–12 %.

The disadvantage of a given system is the scheme of air supply on the burners, to ensure the necessary air injection. The proposed technique implies the supply of air under significant overpressure, which is possible only when adding pumps to the design of the furnace or through its supply directly on the burners from the atmosphere.

The first technique implies the modification of a furnace, which is quite costly. When applying the second technique, the temperature of the additional air used for baking is much less than when it is passing through the chamber, which is under a cooling regime. In accordance with this, the flame temperature decreases and, therefore, ensuring the appropriate temperature mode requires an increase in fuel consumption.

Study [5] proved the efficiency of using neural network modeling of quality indicators of the baking process in order to operatively control these indicators. The advantage of a given approach is the possibility to determine the non-measurable quality indicators of the baking process based on measurable and controlling parameters with the help of artificial neural networks.

A strategy of the optimum control over a thermal object was elaborated by the synthesis and comparative analysis of systems for the criterion of minimum cost based on the optimal PID-controller and neural network predictive controller. The initial configuration of the PID-controller coefficients was defined by the Ziegler Nichols method. The author concluded that the results of the designed control systems operation demonstrate overshooting, which is 33 %, and necessitate the search for alternative solutions regarding the synthesis of the system to control the process.

Paper [5] proposed the possibility to improve the quality of control over the baking process temperature regime by synthesizing a control system using the Neural Network Predictive Control (NN PC). The NN Predictive Control unit contains two neural networks: the neuro controller Optim and NN Model. NNPC uses the NN Model of an object to predict its input effect response. The Optim NNPC unit computes the controlling influences that minimize the set criterion, predicts the object behavior based on the model at the assigned step of the forecast (Nu) and then gives to the object a controlling signal of the optimum magnitude.

The result of the synthesis and simulation of the systems of automated control over an object by the authors of work [5] implies that the required quality of control over a temperature mode is ensured both by the optimal PID-controller and the neural-network predictive controller. However, the best quality indicators for the control parameters were achieved when using the predictive neural controller. It follows from the results reported in work [5] that the designed control system yields products of the predefined quality and reduces the consumption of natural gas by 14 %.

The author of the cited work demonstrates that over the entire range of gas flow rate control the optimal ratio of gas-air is automatically maintained for the gas-air mixture. Since the temperature of the furnace chamber environment depends not only on the ratio of a gas-air mixture but also on the temperature of its components, the initial temperatures of the components exert significant influence on the furnace temperatures. Under a condition of air supply from the chamber being cooled and, therefore, its pre-heating, the issue of the absence of overshooting has not been resolved in the strategy of optimum control.

Patent [6] describes a method to control the baking furnaces based on a baking indicator. Underlying the idea is the fact that the temperature of the anode and, therefore, its quality, corresponds to the total thermal flux over the entire time of baking. Consequently, the same quality of the anode could be achieved by using different temperature modes until the general heat flux remains unchanged.

Accordingly, one could define the baking index, which represents the time integral of temperatures of the surrounding chimneys. The reference baking index could be easily derived by taking the real temperature curves of the surrounding chimneys for the case when the desired quality of the anodes is ensured. When using this baking indicator as a reference index, one only needs to find a deviation from its reference value.

The result of the combustion mode violation is a change in the baking index; consequently, the qualitative assessment of the anode is altered. When deviating from the reference index of baking the deviation value characterizes the absence or excess of the heat flow to the anode.

Among the applications of the baking index is the compensation for the insufficient or excess heat flow by means of the automated adjustment of the baking temperature curve. A simple calculation reveals that the time period related to the decreasing or exceeding the temperature could be corrected over the remaining time by changing the temperature schedule.

The disadvantage of a given method is its non-versatility when baking articles of different sizes. It is clear that each individual size of the product, or variations in its download, necessitates, first, determining the appropriate reference index of baking, after which it is possible to control a given process according to the proposed algorithm.

The possibility to compensate for the previously accepted deviations from the baking temperature curve would subsequently lead to the need to calculate the maximum allowable value that could be compensated for over the remaining time, without the emergence of defects in billets. As a result, there is a possible situation when the baking reference index is not achieved within the remaining time because of the need to maintain temperature constraints.

Work [7] addresses the main issues that arise in the course of baking carbon articles based on experimental results. The obtained results of computational experiments demonstrated that the heat, accumulated by the furnace masonry and filling, significantly complicates control over a temperature regime. That makes it possible to assert that baking furnaces have the following disadvantages: limited ability to ensure minimum temperature changes and to regulate the heating rate of blanks; significant heat consumption for heating the masonry and filling.

Eliminating the above shortcomings requires upgrading the heating system of furnaces, making changes to their design, and improving the system of monitoring and adjusting the temperature regime of the baking process. The possible options for resolving these issues, proposed by the authors in work [7] include the following: the application of pulse heating systems. Under the conditions of pulse heating of blanks in the filling, its considerable thermal resistance plays a positive role because it contributes to the reduction of direct thermal impact on blanks. However, given such a heating system, there remains an unresolved issue to completely burn the volatile substances. And the shortcomings described in [3] remain here.

The production efficiency and the accuracy of temperature control in a conventional closed furnace are low. To solve the task of improving the furnace efficiency, paper [8] presented a temperature control system in a continuous diffusion furnace. The system uses a PID-cascade control algorithm based on the assessment of a preliminary compensation to execute the furnace temperature control.

A conventional control system based on the PID-controller could satisfy the system requirements in most cases but not in the process of controlling an object with nonlinear temporary changes.

Currently, the main issues for a system of temperature control in a diffusion furnace are the duration of heat transfer, which is too long from the furnace wall to the middle of the furnace, which necessitated the construction of an algorithm of the PID-cascade control based on the Smith estimates of prior compensation.

Adding a new control object, the furnace wall, based on the original control object, the furnace chamber, could in advance prevent the shortcomings in changing the controlling value. Therefore, a preliminary analysis of the change in a furnace wall temperature could improve the quality of the entire control system.

Applying a cascade-based control, based on the Smith estimates of prior compensation, in the development of a control system for a multi-chamber baking furnace has a number of advantages; however, given the object's inertia, even the expectation of a furnace temperature change at some key stages takes quite a long time. Consequently, the incorrect controlling influence would lead to the irrational use of certain resources. However, the use of the prediction of a furnace wall temperature for a given algorithm resolves the above issue of inertia.

Our analysis of existing control systems over the process for baking carbon articles has revealed that the main issues when designing control systems are the additional suction of air, the temperature of the air used for subsequent combustion, the inertia of the process, and overshooting.

It is obvious that modeling an object as a sequence of interconnected basic stages of the baking process makes it possible to resolve the issue associated with the temperature of the air used for subsequent combustion. The predictive-based approaches could resolve the issues arising as a result of the process inertia as well as forecast probable overshooting. In addition, the absence of a possibility to evaluate the quality or degree of readiness of articles in the course of the baking process predetermines a transition from classical control systems to predictive control systems.

3. The aim and objectives of the study

The aim of this study is to synthesize an automated control system for a multi-chamber baking furnace, which would enable the production of defect-free articles of appropriate quality at a minimal energy cost.

To accomplish the aim, the following tasks have been set:

- to define a quality indicator for the readiness of products from the process for baking carbon articles;
- to define a quality indicator for the finished articles from the process for baking carbon articles;
- to design the structure of an automated control system for a furnace that bakes carbon articles while minimizing the probability of defects;
- to investigate the efficiency of the proposed control system in comparison with existing systems.

4. A multi-chamber furnace for the baking of carbon articles as an object of automated control

A standard multi-chamber furnace is composed of two rows of rectangular chambers interconnected on the ends by a radial flue gas system – fire channels. A general representation of the multi-chamber baking furnace with a removable vault designed by RIEDHAMMER is shown in Fig. 1.

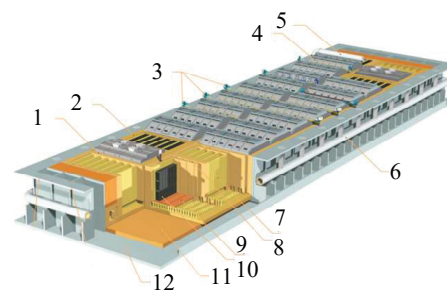

Fig. 1. The structure of RIEDHAMMER furnace for baking carbon graphite articles: 1 – cassette chamber; 2 – filling; 3 – ramps with burners; 4 – vault; 5, 6 – equipment to release and transport flue gases; 7, 8 – end and side muffle channels; 9 – hearth; 10 – blanks; 11 – brick masonry; 12 – concrete

To consider the operation of a multi-chamber furnace, we shall use the scheme of the baking process in a group of chambers shown in Fig. 2. Consider the case when the ramps with burners are installed on chambers 7, 8 (Fig. 2).

Gas is mixed with air or flue gases that pass through chamber 9 and 8, respectively, and is burnt under the vault and in the fire channels of chambers 7, 8. Thus, in chambers 7, 8, one maintains the maximum temperature of the process or, as it is customary during production, the chambers are kept “under a fire mode”. Combustion products are not discharged immediately into the chimney but pass through a series of chambers 3–6 and heat the carbon-graphite articles loaded into them; they are thus cooled.

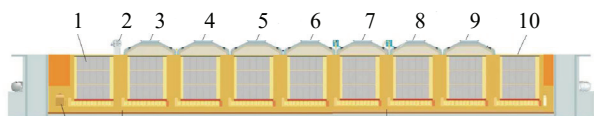

Fig. 2. Scheme of baking the blanks in a multi-chamber closed-type furnace: 1 – chamber for loading; 2 – equipment to release flue gases; 3–6 – chambers that are heated by flue gases; 7, 8 – chambers “under a fire mode”; 9 – chamber being cooled; 10 – chamber for unloading

The air, required to burn the gas, preliminary passes through chamber 9, which hosts the electrode blanks, already baked, at a sufficiently high temperature (up to 1,000 °C). Thus, the air to burn natural gas is heated and fed to chamber 8 with a temperature of 250–350 °C.

Upon completion of baking, the gas supply is terminated, and the ramp with burners is taken to the next chamber in the direction of the flue gas movement. In this case, chamber 9 is disconnected from the group of chambers involved in the process because it is already sufficiently cooled and is to be arranged for unloading, while chamber 1, which has been loaded, is to be connected to the group of chambers. Fig. 3 shows the schematic of gas movement in the cross-section of a baking furnace chamber.

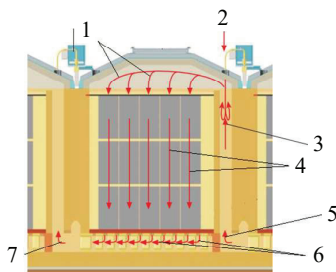

Fig. 3. Schematic of gas movement in a baking furnace chamber: 1 – hot flue gases under the vault; 2 – natural gas supply; 3 – combustion; 4 – hot flue gases in muffle channels; 5, 7 – heated air and flue gases, respectively; 6 – movement of flue gases under the hearth

Natural gas is burnt under the vault of the furnace and in fire wells. The flue gases out of the space under the vault of the furnace chamber arrive through the muffle channels under the hearth of the chamber. The flue gases then enter the next chamber through the fire wells.

Taking into consideration that the process for baking carbon articles consists of three main stages such as heating with flue gases, a chamber “under a fire mode”, and cooling, the adequate simulation of such a process and the derivation of the appropriate temperature fields involved

the implementation of three complete mathematical models of these stages based on the mathematical model given in [9]. The examined cassette of the baking furnace the size of 3.8×0.76×4.05 m has the geometry shown in Fig. 4.

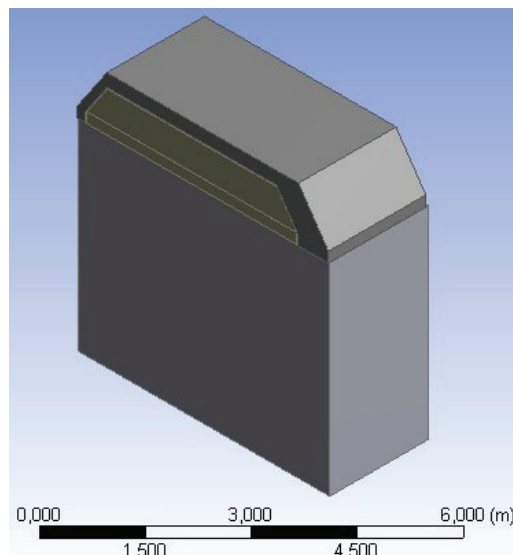

Fig. 4. Geometry of the baking furnace cassette

This paper considers one of the chambers in a multi-chamber closed-type baking furnace, into which 5 workpieces with a diameter of 700 mm and a height of 2,100 mm are loaded. The numbering of the workpieces is given from left to right (starts from a fire well).

5. Determining the readiness of articles in the process for baking carbon articles

The product readiness criterion that is proposed here is the entropy of carbon articles. A change in the state of carbon materials exposed to heat treatment is accompanied by a change in their thermodynamic properties. In particular, such changes in the baking process would occur due to entropy. And a change in the entropy is determined only by the initial and final states of the carbon matter and does not depend on the path of transition from one state to another.

The entropy of a solid body could be regarded as the sum of products consisting of two components – configuration and vibration [10]. Moreover, the configuration component characterizes the perfection of the crystalline structure of a solid body; the greater the structural disarrangement, that is the less perfect the structure of a solid body, the larger its entropy. While the reduction in entropy could be associated with the increasing order within the material’s structure, its growth requires another interpretation. Probably, the increase in the entropy of the carbon material in the pre-crystallization stage could be associated with the emergence and formation of the next (turbostratum) structure and the processes of removal of heteroatoms from the treated carbon substance [10].

According to the above, while the baking process is accepted as the beginning of the pre-crystallization stage, a change in the sign of the change (gain) in entropy from a plus to minus would characterize the beginning of the

pre-crystallization stage, where growth in the structural orderliness starts.

The task of determining the entropy transition value comes down to finding a local maximum on the plane entropy (Fig. 5) at a known final treatment temperature.

Thus, the application of entropy in the course of the baking process makes it possible to determine the readiness of articles and the moment of the process completion in general.

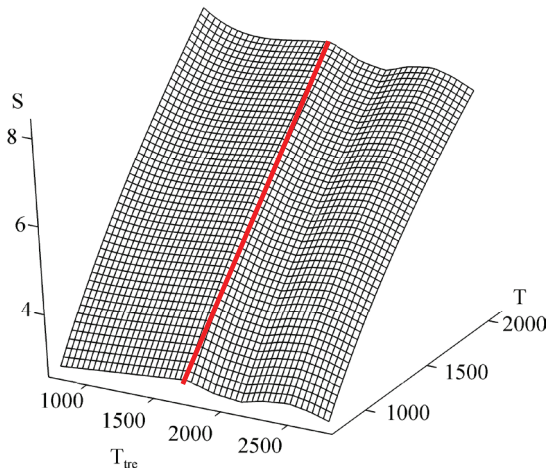

Fig. 5. The plane of entropy depending on the treatment temperature and the current temperature of a material: S – entropy; T – current temperature; T_{tre} – final treatment temperature

6. Quality assessment of the finished articles in the process for baking carbon articles

At present, given the increased computing capacities, artificial neural networks are becoming more widespread to solve a wide range of issues. The general range of tasks solved by artificial neural networks includes the classification of images, clustering/categorization, reduction of dimensionality, the approximation of functions, prediction/forecasting, etc. [11, 12].

It is clear to us that the projected data, under all possible control options, can serve a basis to form an entropy plane as the indicator of product readiness. By choosing the point of product readiness, that is the endpoint of the baking process, it is possible to form control that would make it possible to achieve the endpoint from the initial conditions. Moreover, the calculated control would make it possible to obtain articles of the specified quality based on the predefined criterion, for example, minimizing the treatment time or minimizing the consumption of fuel.

At the same time, an important point, which should be taken into consideration in the synthesis of the baking process control system, is the fact that the implementation of estimated control may violate the integrity of a workpiece because of its non-compliance with temperature constraints. Violating the temperature constraints results in that the billets experience thermal stresses that, when reaching the threshold, could lead to a defect in blanks in the form of cracks. An obvious solution to this issue is to restrict control within the range assigned by technologists. On the other hand, the violations of temperature constraints make it possible to form a more flexible system

of control over a given process, for example, to reduce the time required for the thermal treatment of blanks.

In order to address this issue, it is proposed to predict the probability of a defect in an article. It is possible to obtain a neural network with the ability to generalize, which would be able to determine the probability of a defect under intermediate modes and under different conditions of the process. By choosing different protocols under which a defect-free structure was obtained in all blanks and the modes under which the defect was received, one could form a sample for training an artificial neural network.

Forecasting the probability of a defect does not contradict obtaining articles of appropriate quality with the predefined thermophysical properties, such, for example, as heat capacity, electrical conductivity, etc.

The development of a given neural network is complicated given the limited amount of experimental data based on which it would be possible to train the network. Our analysis of the scientific literature [13, 14] has revealed that in the case of limited training samples it is advisable to use an autoencoder to retrain a neural network.

Autoencoder is a neural network of direct propagation that restores the input signal at the output from the network; the general structure of an autoencoder is shown in Fig. 6.

One trains an autoencoder based on data about the temperature fields acquired from mathematical modeling, which ultimately produces a neural network that is prepared for use with the assigned number of neurons in the middle layer and, thus, makes it possible to define the properties of carbon articles and, therefore, defects in articles.

Adding to the trained encoder a predictive layer makes it possible to obtain a neural network for determining the probability of a defect with only a single untrained layer (Fig. 7).

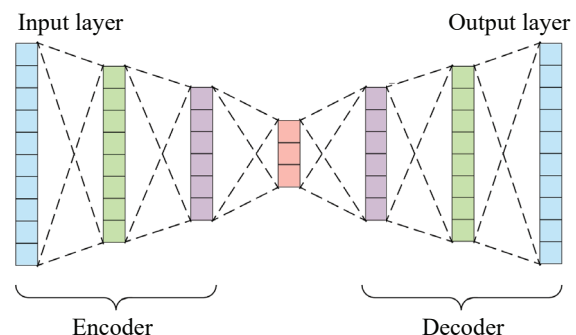

Fig. 6. General structure of an autoencoder

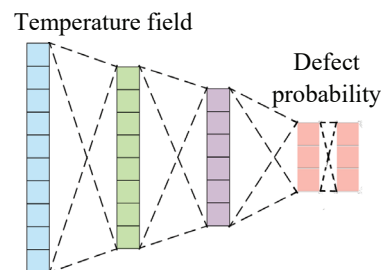

Fig. 7. A neural network for predicting a defect based on an encoder

It is clear to us that further training involves a limited sample with the target values of a defect probability.

We have constructed the neural network based on the neural network library Keras, written in the Python language, which is capable of operating atop the library for machine learning TensorFlow. The environment used here to train the neural network is the international platform for analytics and predictive modeling competitions Kaggle.

7. The general structure of the system to control the process for baking carbon articles that minimizes the defect probability

A general structure of the baking process control system based on artificial neural networks minimizing the defect probability is shown in Fig. 8.

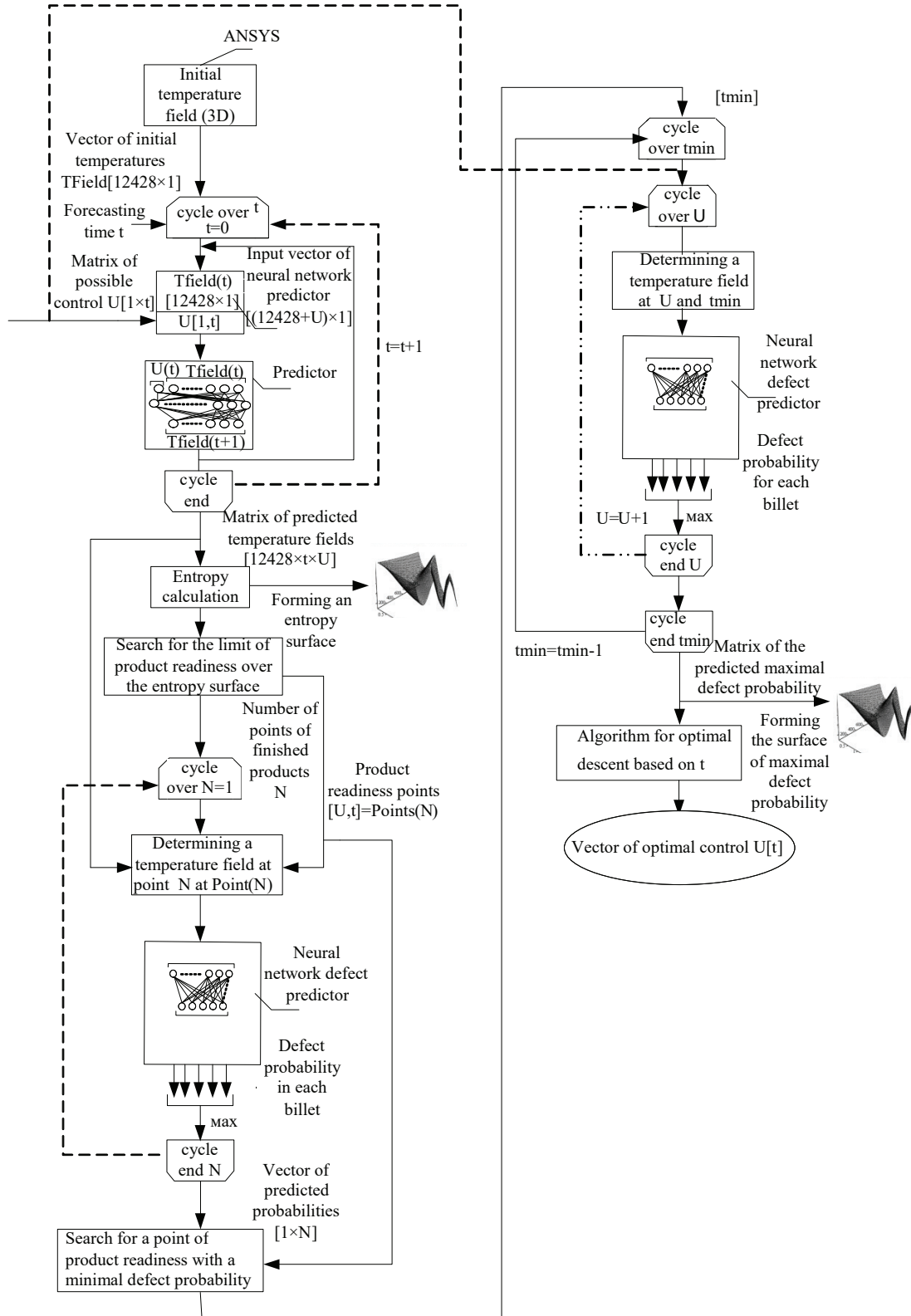

Fig. 8. General structure of the baking process control system based on artificial neural networks

This system operation could be conditionally divided into 4 stages:

1. Forecasting the temperature fields based on the current state of the object at the operator-specified time over the entire range of possible or assigned control based on a mathematical model.

Prediction involved 40 iterations (120 hours) over a range of possible fuel consumption of 0.22–0.36 m/s.

2. The calculation of entropy for each predicted option in the baking process; forming the entropy surface; searching, at the entropy surface, for the limit of the completion of the baking process according to the above-described criterion of product readiness.

Based on the resulting forecasted temperature fields, we built an entropy plane for a single workpiece, shown in Fig. 9. The figure shows the “crest”, which characterizes the completion of the baking process in accordance with entropy as a criterion of readiness. It is obvious to us that this milestone could be achieved in different ways, depending on control and the treatment time.

3. Determining the starting point of descent by determining the defect probability in all blanks for all points from the limit of process completion and choosing a point with a minimum value for defect probability.

To obtain the vector of optimal control, it is necessary to find a defect probability for all possible values of product readiness based on entropy. A point with a minimum probability value would be the endpoint to be achieved.

The result has established that the minimum defect probability for finished articles is reached at the control point whose control index is 1 and whose index of time is 23.

4. Formation of the surface of a defect probability for all possible control options that ensure reaching the starting point of the descent. The optimum descent from a starting point over the surface of defect probability while retaining the route, that is the formation of control value at each point in time.

The results of searching for the first point are given in Table 1.

Table 1

Results of searching for the first point

Number of time steps	Control index	Defect probability
23	1	1.8 %
23	2	2.5 %
23	3	2.8 %
23	4	4 %
22	5	5.3 %
22	6	6.9 %
22	7	8.4 %
22	8	9.7 %
21	9	10.7 %
21	10	11.8 %
***	***	***
16	40	28 %

The derived defect probabilities in all billets were compared to select the maximum value, which was used for the construction of the plane of the maximum defect probability in the course of the baking process (Fig. 10). The plane characterizes a change in the maximum defect probability for all blanks, that is the maximal one among the projected ones at each moment of forecast for each of the blanks.

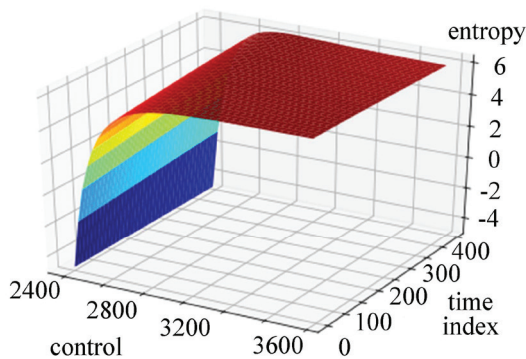

Fig. 9. Plane of the predicted entropy for a reference point

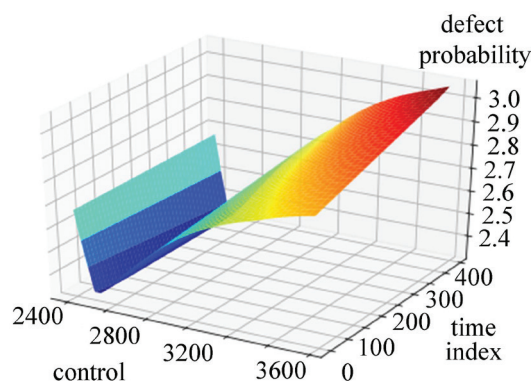

Fig. 10. Plane of the predicted maximal defect probability

The results of calculations indicate that it is necessary, in order to ensure the minimum defect probability, to move from point 23.1 along the trajectory given in Table 2.

Table 2

Trajectory of optimal control

Time index	Control index
1	15
2	10
3	1
4	1
5	1
6	1
***	***
21	1
22	1

Index 1 in control corresponds to a fuel consumption of 0.243 m/s, index 10 – 0.27 m/s, index 15 – 0.285 m/s, and index 23 in time corresponds to 69 h.

8. Investigating the system of control over the process for baking carbon articles that minimizes the defect probability

In order to study effectiveness of the proposed control system for the process for baking carbon articles, it is advisable to compare its operation with a conventional system based on the PID-controller. Simulation was used as a method of research. We employed in our simulation the MATLAB programming environment with the inter-

active tool Simulink for simulating, imitating, and analyzing dynamical systems.

Fig. 11 shows the chart of change in control for both controllers. The results indicate that the proposed control system ensures a lower average value of fuel consumption.

Fig. 12 shows the charts of temperature changes for blanks No. 1 and No. 5 over the entire baking process. The results obtained suggest that the final temperatures in the proposed control system are lower than those when using a system with a PID-controller, which fully agrees with the average values of fuel consumption that are sufficient to achieve product readiness.

Charts of temperature changes in blanks are shown in Fig. 13, 14. The results show that the value of a temperature gain when heating with flue gases is $-2.5...2\text{ }^{\circ}\text{C}$, which meets the recommendations for achieving an integral structure of blanks. The maximum values of change are observed in billet No. 1, the minimal, accordingly, in billet No. 5, which is explained by the furnace operation pattern. At the same time, the proposed control system

demonstrates significant differences in the transition between the phases of furnace operation.

The maximum temperature increase at the stage when a chamber is “under a fire mode” is about $120\text{ }^{\circ}\text{C}$, the average, respectively, $4-3\text{ }^{\circ}\text{C}$; and for the neural network controller, the temperature increment chart is below in the range by 20–40 hours than that for the PID-controller, which positively characterizes the proposed control system.

The experimental research involved a single chamber of the multi-chamber closed-type baking furnace with automation tools used at the enterprise at that moment. The applied reference point was a point under the vault of the furnace, where it is physically possible to install a measuring instrument, namely, a tungsten-rhenium thermocouple. The choice of a given point is predetermined by its capability to characterize, to a largest degree, the baking process, as it is under the vault of the furnace where the main volume of flue gases is concentrated as a single heat carrier [9]. Results from studying experimentally the designed system are shown in Fig. 15.

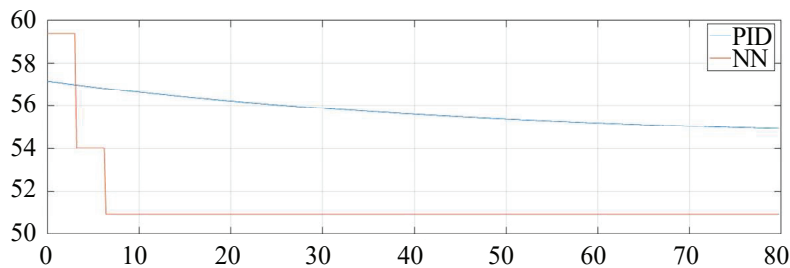

Fig. 11. Chart of change in control

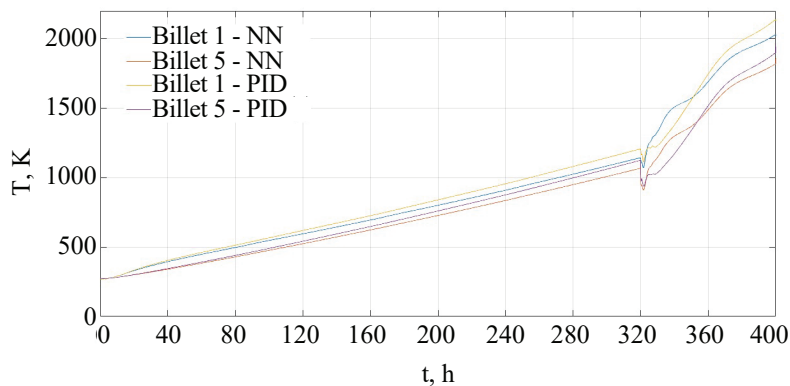

Fig. 12. Chart of temperature changes in blanks in the course of the process for baking carbon articles

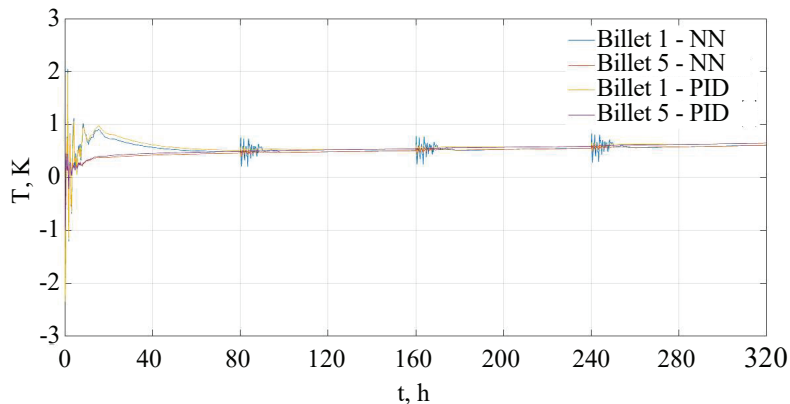

Fig. 13. Chart of change in the temperature gain for blanks at the stage when a chamber is heated with flue gases

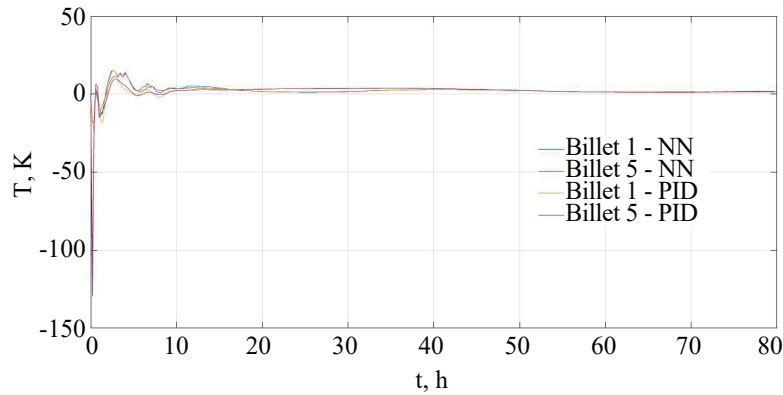

Fig. 14. Chart of change in the temperature gain for blanks at the stage when a chamber is “under a fire mode”

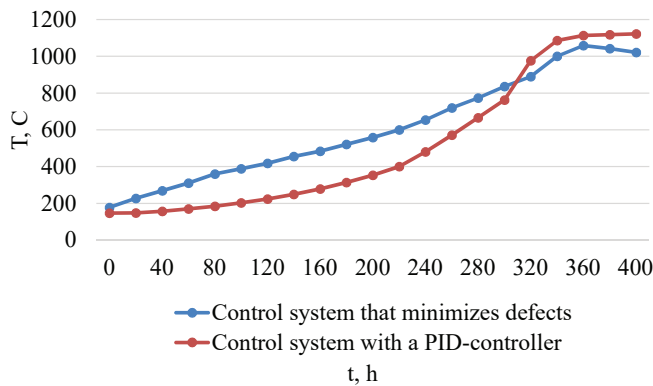

Fig. 15. Results of experimental study

Our experimental research results indicate a significant deviation of temperatures from the maximum value at all stages of baking. At the stage of heating with flue gases, the proposed system shows the higher temperature values, on average, by 150–200 °C, although, when a chamber is “under a fire mode”, the measuring device registered lower values. This positively characterizes the designed system because it is at the stage when a chamber is “under a fire mode” that cracks appear in billets because of the significant temperature changes.

When applying the proposed control system, the character of the process is significantly different and is more aggressive in nature; it, however, ensures that such carbon blanks are received that meet all the requirements as regards the quality of the finished products and with their structure being defect-free.

A decrease in the temperature at hour 370 characterizes the completion of the baking process; thus, compared with the analog, the duration of the baking process is reduced by 30 hours.

9. Discussion of results of synthesizing a control system for the baking process

The process of baking of carbon articles is characterized by significant energy costs for its performance. Given this, determining the reasonable duration of a given process, which would ensure the required quality indicators of articles (heat capacity, electrical conductivity, etc.), is an important scientific and practical task. At present, the baking process duration is determined empirically, based on the experience of operational staff. No quantitative criteria exist. Given that all qualitative

indicators of carbon articles are defined by the baking process modes, it is proposed to apply, as the criterion of product readiness at this technological stage, the entropy of articles, whose nature of change is extreme (Fig. 5). Predicting temperature fields in the course of the process using a mathematical model makes it possible to determine the extreme point of the process, which would be the point of appropriate baking completion (Fig. 9).

The operating volume of a baking chamber is characterized by considerable temperature distribution, which leads to the fact that, while providing the necessary temperature mode for one zone in the baking chamber, there is the overheating of blanks in another zone, resulting in the defects of articles, the percentage of which could be quite significant. It is proposed to solve the task of reducing rejected products by using a probabilistic approach based on the analysis of “successful” and “unsuccessful” baking processes. Neural networks are used to simulate such a process. The task of neural networks training is solved with the help of an autoencoder (Fig. 6). The calculation of a defect probability is performed in relation to the workpiece in which the defect is most probable.

Based on the proposed criterion of the readiness of carbon articles and a method for determining the maximum probability of producing defective articles, we have designed a general control system for the baking process (Fig. 8). According to proposed structure, the calculation of control is carried out in 4 stages. The given examples of calculating the initial point of the system movement (Table 1) and the optimum motion trajectory (Table 2) demonstrate the practical orientation of the reported general structure of a control system.

Our study of the proposed control system has demonstrated that in comparison with a PID-controller-based system the temperature increases are smaller in the proposed system, which positively influences the quality of the finished articles. Although the use of the designed system yields the temperatures at the stage of heating with flue gases that are higher by 150–200 °C than those with a PID-controller-based system (Fig. 13), at the next stage, when a chamber is “under a fire mode”, they are lower (Fig. 14). And it is more important because it is at this stage that the temperature modes are the highest, in connection with which the probability of defects in the form of cracks is the largest. The duration of the baking process under conditions of using the proposed control system is 30 hours less (Fig. 15).

When implementing the baking process control system that minimizes the probability of defects, the problematic issue is to train a neural network, which, to some extent,

complicates its application. Further investigations should be directed at resolving this issue.

10. Conclusions

1. Entropy has been proposed as a criterion of product readiness in the process of baking of carbon articles. A possibility to use a given criterion is predetermined by the extreme nature of change in the entropy of carbon articles in the process of their thermal treatment (Fig. 5). Forecasting a point of extremum makes it possible to determine in advance the appropriate duration of the baking process, which, given the energy intensity of the process, would increase its economic efficiency.

2. The proposed method for determining the probability of a defect in carbon articles, based on artificial neural networks, implies the reduction of rejected articles provided all requirements to the quality of the finished products (heat capacity, electrical conductivity etc.) are met. The issue of

limited data for training a neural network is resolved by retraining an autoencoder (Fig. 6).

3. We have designed a general structure of the system to control the baking process of carbon articles (Fig. 8), which includes 4 stages of its operation. In contrast to actual control systems, a given system makes it possible to comprehensively solve the task of managing the process, by computing the appropriate duration of the baking process, thereby ensuring the minimization of the probability of producing defective articles while maintaining the predefined quality indicators.

4. The results of simulating a control system with the PID-controller and the proposed control system indicate that the average value of fuel consumption, when using the latter, is 3–4 m³/h less, and there is a lower temperature increase over the range of 20–40 hours at the stage when a chamber is “under a fire mode” and the stage of “heating with flue gases” (Fig. 13, 14), which contributes to the improved quality of finished articles; the duration of the baking process is reduced by 30 hours for the given example.

References

1. Soshkin, S. V., Apriamov, V. N., Zhukovetskiy, O. V. et. al. (1988). Impul'snaya sistema upravleniya temperaturnym rezhimom obzhigovyh pechey. *Tsvetnaya metallurgiya*, 11, 36–37.
2. Pekker, I. I., Savin, M. M., Vasil'eva, V. D. et. al. (1976). Vozmozhnosti avtomatizatsii obzhigovoy pechi. *Sovershenstvovanie tehnologii i uluchshenie kachestva elektrodnoy produktsii*. Chelyabinsk, 77–87.
3. Soshkin, S., Antonyan, A., Poltorak, G., Sorokin, N. (2006). Sistema upravleniya protsessom obzhiga elektrodnykh materialov. *Sistemnaya integratsiya*. *Metallurgiya*, 3, 26–32.
4. Malahov, S. A. (2004). *Sovershenstvovanie tehnologii obzhiga uglegrafitovoy produktsii v mnogokamernykh pechah obzhiga zakrytogo tipa*. Vladikavkaz.
5. Soshkin, G. S., Rutkovskii, A. L., Soshkin, S. V. (2011). Development of a control system for roasting carbon-graphite materials based on modeling quality characteristics of roasted products. *Russian Journal of Non-Ferrous Metals*, 52 (5), 457–461. doi: <https://doi.org/10.3103/s1067821211050117>
6. Leisenberg, W. (2002). Pat. No. US 6,436,335 B1. Method for controlling a carbon baking furnace. No. 09/547,492; declared: 12.04.2000; published: 20.08.2002.
7. Kostikov, V. I., Krupennikov, S. A., Shibalov, S. N. (2003). Razrabotka ratsional'nykh rezhimov teplovoy raboty plamennoy pechi dlya obzhiga uglegrafitovykh zagotovok. *Izvestiya VUZov. Chernaya metallurgiya*, 11.
8. Ke, X., Luo, Z., Zhu, Y., Liu, Y. (2016). The Temperature Control System of Continuous Diffusion Furnace. *Proceedings of the 13th International Conference on Informatics in Control, Automation and Robotics*. doi: <https://doi.org/10.5220/0005996402270233>
9. Karvatskiy, A. Ya., Pulnits, I. V., Shylovykh, I. L. (2012). Mathematical model of heat-hydrodynamic state of the multichamber furnace during the baking of electrode blanks. *Eastern-European Journal of Enterprise Technologies*, 1 (4 (55)), 33–37. Available at: <http://journals.urau.ua/eejet/article/view/3316/3117>
10. Shulepov, S. V. (1972). *Fizika uglegrafitovykh materialov*. Moscow: Metallurgiya, 256.
11. Bengio, Y. (2009). Learning Deep Architectures for AI. *Foundations and Trends® in Machine Learning*, 2 (1), 1–127. doi: <https://doi.org/10.1561/2200000006>
12. Bengio, Y., Couville, A., Vincent, P. (2012). Unsupervised Feature Learning and Deep Learning: A Review and New Perspectives. Available at: <https://docs.huihoo.com/deep-learning/Representation-Learning-A-Review-and-New-Perspectives-v1.pdf>
13. Deng, L. (2014). A tutorial survey of architectures, algorithms, and applications for deep learning. *APSIPA Transactions on Signal and Information Processing*, 3. doi: <https://doi.org/10.1017/atsip.2013.9>
14. Rumelhart, D. E., Hinton, G. E., Williams, R. J. (1986). Learning Internal Representations by Propagation Parallel Distributed Processing. Vol. 1. *Foundations Cambridge*. MIT Press, 318–362.
15. Rumelhart, D. E., Hinton, G. E., Williams, R. J. (1988). Learning Representations by Back-propagating Errors. *Neurocomputing: Foundations of Research*. MIT Press, 696–699.