

Січні води, що утворюються на промислових і комунальних об'єктах, піддаються очищенню у межах норм допустимих значень, встановлених законодавством. Стоки транспортної і туристичної інфраструктури у більшості випадків очищаються при наявності локальних очисних споруд. Для очищення стічних вод найчастіше використовується біологічний метод, який реалізується на складних і громіздких очисних, розміщених на значних територіях. Очищення стічних вод з малих об'єктів запропоновано здійснити локально за фізико-електрохімічною технологією з компактним устаткуванням. Розроблено конструкцію пристрою для обробки стічних вод з електродами циліндричної форми, які розміщені коаксіально корпусу пристрою. Показано, що на першій стадії очищення комунальних стічних вод в лабораторній установці з відповідними параметрами (кут нахилу площин в тонкошаровому відстійнику=45° і напруга на 1-му електричному пристрої з розчинним анодом=12 В) забезпечується ступінь очистки від завислих до значень 95,8%. Очищення комунальних стічних вод на другій стадії очистки (2-й електричний пристрій з інертним анодом під напругою 10 В і фільтрація через шар цеоліт кліноптілоліта) збільшує ступінь їх очищення від завислих до значення 96,1%. Обробка стічних вод автомийки в першому електропристрої перед тонкошаровим відстійником та в 2-му електричному пристрої з інертним анодом під напругою 10 В і фільтрацією через шар цеоліту кліноптілоліта, збільшує ступінь їх очищення від нафтопродуктів до значення 95,6%. Технологія за участю розроблених електропристроїв приводить до збільшення ступеня очищення стічних вод за показником ХСК до 97,0%, яка дає змогу зменшити скид забруднень у довкілля на рівні 50–70%.

Ключові слова: стічні води, фізикоелектричне очищення стоків, цеоліт кліноптілоліт, ХСК, завислі

WASTEWATER PURIFICATION TECHNOLOGY BY TWO-STAGE TREATMENT IN ELECTRICAL DEVICE OF A COMPACT LOCAL INSTALLATION

L. Chelyadyn

Doctor of Technical Sciences, Professor

Department of Chemistry*

E-mail: chelyadyn@ukr.net

V. Kostyshyn

Doctor of Technical Sciences, Professor, Head of Department

Department of Electric Power Engineering,

Electrical Engineering and Electromechanics*

V. Chelyadyn

PhD, Researcher

Joint Educational and Scientific Laboratory for

Physics of Magnetic Films No. 23

G. V. Kurdyumov Institute for Metal Physics of the National

Academy of Sciences of Ukraine

Akademika Vernadskoho Blvd., 36, Kyiv, Ukraine, 03142

T. Romanyshyn

PhD, Associate Professor

Department of Oil and Gas Field Machinery and Equipment*

E-mail: tarasromanushun@gmail.com

V. Vasechko

Department of Electric Power Engineering,

Electrical Engineering and Electromechanics*

E-mail: vvasechko2006@gmail.com

*Ivano-Frankivsk National Technical University of Oil and Gas

Karpatska str., 15, Ivano-Frankivsk, Ukraine, 76019

Received date 20.05.2020

Accepted date 16.06.2020

Published date 30.06.2020

Copyright © 2020, L. Chelyadyn, V. Kostyshyn, V. Chelyadyn, T. Romanyshyn, V. Vasechko

This is an open access article under the CC BY license

(<http://creativecommons.org/licenses/by/4.0>)

1. Introduction

At the present stage of development of society, environmental protection problems are of particular relevance, since the processes of reducing the emission of pollution into water resources are effective. An analysis of the environmental situation indicates that despite a significant decline in production, the level of environmental pollution remains high. One of the main factors of environmental pollution and environmental safety is the discharge of wastewater into natural water resources, as they contain hazardous components. Very often, the main pollutants of both natural water bodies and soil [1, 2] are petroleum products (a group of hydrocarbons of oil, fuel oil, kerosene, oil and their impurities). Through their high toxicity by

international standards, they are among the ten most dangerous components of environmental pollution. The environment is especially polluted by wastewater from industrial facilities (compressor stations of the pipelines of combustible hydrocarbons, gas stations, car washes, summer military training camps and rural schools), which are located far from urban wastewater purification plants.

Globally on planet Earth, more than 80% of all wastewater is discharged without treatment [3]. In Ukraine, during 2014–2017, about 3.5 billion m³ of wastewater were discharged into Ukrainian water bodies [4].

Small utilities discharge wastewater in smaller quantities, but their composition is always specific. Contaminant content can be significantly greater than the allowable discharge value.

The number of cars on the roads is constantly growing and the scope of their service, namely, the number of gas stations, car washes along the roads is growing every year, therefore, the amount of wastewater from these facilities increases accordingly.

Wastewater generated at small facilities (up to 100 m³ per day) is communal (tourist estates, summer camps for schoolchildren, military exercises, recreation facilities on the sea coast, rural schools, infectious diseases hospitals outside settlements) and infrastructure (gas stations, car washes, campsites) are generally not cleaned on site. They are discharged into municipal wastewater networks of cities or towns directly into rivers and are not treated at all, which leads to pollution of water resources.

In Ivano-Frankivsk region, about 300 million m³ of wastewater was discharged in 2018 [5, 6], including additionally small objects. Approximately their number for the Ivano-Frankivsk region [7] in 2017 amounted to about 269.0 thousand m³. The amount of pollutants discharged with wastewater in 2017 was as follows: suspended, in tons – 9.2; dry residue, in tones – 358.3; oil products, in kg – 47.0; Calcium, in tones – 47.8, NO₂⁻, in tones – 0.6; Cl⁻, in tones – 52.1; P₂O₅, in kg – 1.96.

So, the wastewater discharge into the hydrosphere negatively affects the quality of water that the population consumes. Therefore, the discharge of polluted effluents into water from small objects without treatment is an extremely urgent problem.

2. Literature review and problem statement

To develop a technology for wastewater purification from small treatment facilities, realistically drained waste water from Ivano-Frankivsk are used. According to [7], in 2017 in the Ivano-Frankivsk region 250 thousand m³ of municipal wastewater were discharged from the city of Ivano-Frankivsk. In the wastewater of oil transportation enterprises and road infrastructure (overpass, gas station, car wash) There are oil and oil products, which, after water separation, can be collected in the national economy. Chemical impurities, such as detergents, are separated by special chemical methods, and therefore it is advisable to use separate wastewater collection and a combined treatment system here.

Basically, treatment facilities include mechanical, physico-chemical, biological treatment [8]. Mechanical purification facilities include sand traps, oil traps, water traps, and others, where coarse-dispersed impurities are visible, and physicochemical treatment facilities include plants [9], which congeal chemical reagents, such as coagulants for colloidal impurities.

A review of publications [10, 11] on wastewater purification and equipment designs shows that they mainly use earthen open windows and biological treatment, which is energy-intensive. Such treatment facilities occupy large territories, and the purification degree is 65–75 % of the dependent and even less oil products, which values affect the pollution of water resources and the atmosphere.

The effective treatment of wastewater from pollution, including oil and gas, sulfides and others, is given in publications [12, 13], which describe technologies that include the stages of physicochemical wastewater purification. The basis of wastewater purification is the separation of stuck

particles by the sludge method or through various types of porous loading in filters. They differ in chemical composition and have different sizes of particles of filter material and adsorption capacity.

For the wastewater purification that contains petroleum products, the technology with a flotation stage under a vice is wider. Wastewater purification from oil products, the concentration of which in wastewater is set at about 10 mg/dm³ and in accordance with the maximum permissible concentration standards of 0.1–0.3 mg/l is carried out according to the folding scheme [14]. It includes their interests in settling traps, coagulation of contamination by the coagulant action – iron sulfate and lime. The next stage of purification is flotation and filtration of wastewater through quartz and sulfur-carbon filters.

A review of recent improvements in wastewater purification at oil refining facilities is given in [15, 16], which describes various modern electrochemical technologies: membrane filtration, UV treatment and other methods of destabilization of sorption treatment emulsions.

An electrochemical method for wastewater purification of an industrial enterprise is proposed [17]. The need to use this method is explained by a significant increase in the price of chemicals, such as oxidizing agents, reducing agents, acids, alkalis, coagulants and flocculants. In addition, this method reduces the “secondary” contamination of purified water by anions and salt cations due to the rejection of the use of chemicals. The electrochemical method has a positive effect on increasing the possibility of reuse of purified water in production, which increases the environmental safety of enterprises [18]. As a result of the electrical purification of wastewater with a soluble anode, hydroxides are formed that cause sorption and co-precipitation of impurities; which leads to a decrease in the number or to a complete rejection of the use of coagulation reagents.

Current trends in water purification [15, 19] are aimed at conducting local wastewater purification for certain industries. This is due to the fact that they contain two or three environmentally hazardous components that can be more easily separated and disposed of. A complex water system, formed by mixing wastewater from various industries, is extremely difficult to clean up from pollution, since each particular pollutant requires a specific process and its implementation parameters.

Various wastewater purification plants are used for wastewater purification, in which the main equipment for the separation of mechanical impurities (suspended matter) is open-type settling tanks, which occupy large areas, pollute the atmosphere, and the degree of purification is 55–60 %. The authors of [20] develop an improved design of a thin-layer sedimentation tank, which is small in size and of sufficiently high efficiency. Suspended separation is often carried out using filters [21], in which various filtering materials are loaded – silica sand, slag, activated carbon and others. In the publication [22] it is shown that the filtering material based on clinoptilolite zeolite is effective for the purification of Mn²⁺ cations. Other researchers confirm the sorption properties of this zeolite in other cations [23]. Such a zeolite is used for filter loading of an automatic adsorber filter [24]. Based on the developed equipment, the authors propose a facility with physicochemical methods for wastewater purification using carbon-mineral materials for filter loading [25].

The literature and patents describe various designs of electrical appliances for treating the aquatic environment. Many studies on the wastewater purification by the electrochemical method are presented in publication [26], which shows the influence of the pH of the medium on the separation process of contaminants in an electrolytic cell with flat electrodes and the optimal parameters for purification of chromium waste. The main difference between such devices is the shape and material and placement of the electrodes between which the aqueous medium flows, since various electrochemical processes occur from their size, shape and material of the electrodes in the aqueous medium.

The publication [27] describes the use of an electrocoagulator for the dye destruction, in which the electrodes are located in parallel in a horizontal container.

The well-known "Electrocoagulator for water purification" [28], which contains a container in which there is a cathode grid and anode blocks, is covered with steel shavings and bounded on both sides by a nylon grid. The disadvantages of the device include the complexity of the design, which causes significant operating costs when replacing the anode blocks, since they quickly dissolve, and the degree of purification from suspended is low.

The authors of [29] developed the design of an electrocoagulator containing a body with a conical bottom made of a dielectric material, inside of which there is a cathode and anode, which is made in the form of a container with perforated walls and filled with anodically soluble material. The body of the anode capacitance is made of titanium, and the cathode in the form of two plates mounted vertically, curved in the shape of the anode. The main disadvantages are as follows: the electrocoagulator has a complex structure, which creates significant operating costs when loading the anode tank with iron chips. In this device, due to the large number of structural elements, the sealing of gases released during electrical sampling is not provided. In addition, there is a low degree of purification, which is associated with a low current density. This limits the formation of the necessary amount of coagulant and oxidizing agent to neutralize contaminants in the water.

A "Device for the electrochemical purification of water" [30] is proposed, which comprises a body made of dielectric material, in which a cathode made in the form of a spiral from titanium wire or stainless steel or other materials, and a conical cover for venting gases are placed. The anode is made of materials stable in acidic and oxidizing environments. The disadvantages of the device is the design complexity due to the large number of elements to ensure sealing of the device; the low degree of purification, which is due to the small surface area of the electrode, causes an insufficient amount of oxidizing agent to neutralize contaminants in the water.

Based on the foregoing, the biological treatment of wastewater, taking into account the increase in energy prices that are used by energy-intensive compressors to supply oxidizer, and the need to occupy large areas, is not effective enough for small facilities.

The purification of effluents containing organic and inorganic contaminants is mainly carried out according to the physicochemical technology of wastewater purification. The fundamentals of physico-chemical wastewater purification are based primarily on the separation of dispersed particles by sedimentation and are determined by the sedimentation rate of the particles of the dispersed phase under the influence of gravitational force. The deposition process depends

on the size and charge of the particles, which vary due to factors that violate the aggregate stability of the dispersed system, namely: the activity of the coagulator reagent, temperature changes, the intensity of mixing, light and various kinds of radiation, the effects of electrical discharges. The greatest influence on the purification efficiency has reagent coagulants, which are currently of high cost. The technology of physico-chemical wastewater purification due to the cumbersome and structural complexity of maintenance of treatment equipment and the high cost of chemicals for local wastewater purification of a small facility is also impractical.

Information on the amount of wastewater, their detailed characteristics, in particular on the content of impurities and especially the requirements for purified water, affecting the choice of method for wastewater purification plants. The technology and equipment for treatment depends on the amount of wastewater, the content of specific contaminants and their content in wastewater.

An important factor in choosing a purification technology is the quality requirements for purified water for re-supply or discharge into a body of water, and the availability of district or city treatment facilities.

Therefore, it is necessary to develop technologies that have small-sized water purification equipment and do not use chemicals for water purification, as well as simple ones for implementation at local installations.

For small facilities, the main requirement for water purification technology is the quality of the purified water, it is ensured by simple environmental technology and the compactness of the equipment and allows its use in remote areas from settlements, reverse water supply or discharge into a reservoir.

A more effective water purification technology for small objects can be a combination of sedimentation processes, electric treatment and sorption filtration with the goal of further purification of wastewater to the required level using compact equipment.

According to the analysis of information sources and patents on technologies and equipment for wastewater purification, a study on the development of a water purification technology that combines the processes of electric purification, settling in a thin-layer sedimentation tank and sorption-filtration through filter material for post-purification of wastewater is advisable.

3. The aim and objectives of research

The aim of research is to improve the technology and equipment of physico-electrochemical wastewater purification, which will increase the purification degree and can be used in local and mobile installations in emergency situations of water supply and sanitation.

To achieve the aim, the following objectives are set:

- develop an improved design of electrical devices for wastewater purification;
- investigate the two-stage physicochemical technology for purifying municipal wastewater for the purification degree from suspended matters;
- establish the effectiveness of the physico-electrochemical technology for the wastewater purification of car washes as a small object using the fractional loading method (filtration through clinoptilolite zeolite) by the amount of the post-purification of oil products.

4. Materials and methods of research

Let's use the real wastewater from the Ivano-Frankivsk-vodoecotechprom communal enterprise, which in composition is close to small tourist sites, and the infrastructural one – car wash in Ivano-Frankivsk. The average main indicators of wastewater at the entrance to the wastewater purification plant of Ivano-Frankivskvodoecotechprom communal enterprise are as follows: pH=7.1–7.4, suspended=87.1–120 mg/dm³, COD=164.0–196 mgO₂/dm³ and ammonium ions=11.7–19.5 mg/dm³. Other indicators of the composition of wastewater utilities are given in Table 1.

charge of hydrogen ions H⁺: H₂O↔H⁺+OH⁻, 2H⁺+2e→H₂↑. H₂ bubbles collide with insoluble particles, stick to them and transport them to the surface, which leads to their electro-flotation to the surface of the aqueous medium. The ions in the solution, reaching the cathode, receive electrons from it, and become neutral atoms or a group of atoms (molecules) that are released on the electrodes along with the products of electrochemical reactions. The complex of electrical contacts (electrical purification) in one apparatus causes the processes of electrocoagulation, electro-flotation, electro-oxidation-recovery, electro-disinfection of water, and therefore does not provide a high degree of wastewater purification.

The composition of the two wastewater samples of a utility company

No.	The name of indicators	Sample 1	Sample 2	Techniques – ND Code
1	pH	7.8	7.4	DSTU 4077-2001
2	COD, mgO ₂ /dm ³	164	196	KND 211.1.4.021-95
3	Dry residue, mg/dm ³	153	434	MVV No. 081/12-0109-03
4	Suspension, mg/dm ³	120	87	KND 211.1.4.039-95
6	Ammonium nitrogen, mg/dm ³	12.8	19.5	MVV No. 081/12-0106-03
7	Nitrite ions, mg/dm ³	1.1	0.96	KND 211.1.4.023-95
8	Nitrate ions, mg/dm ³	0.04	0.04	MVV No. 081/12-0651-09
9	Chlorides, mg/dm ³	53	50	MVV No. 081/12-0004-01
10	Sulfates, mg/dm ³	91	50	MVV No. 081/12-0007-01
11	Phosphate ions, mg/dm ³	5.4	3.7	MVV No. 081/12-0005-01
12	Surfactants, mg/dm ³	0.012	0.010	KND 211.1.4.017-95
13	Oil products, mg/dm ³	<0.005	<0.005	MVV 99-12-98

Table 1

For the wastewater purification of small objects, it is advisable to use the processes of electro-coagulation, electro-flotation and electro-disinfection in oxidation-reduction reactions. Each of these processes should be carried out separately in various electrical installations and at different stages of the water purification technology, which will increase the degree of purification for individual indicators. The selection of an appropriate set of processes for a complex electrical action depends on the source and required quality of purified water.

Research on the wastewater purification of a small facility (car wash in Ivano-Frankivsk) was carried out with real effluents, which are characterized by the following average main indicators: pH=7.1–7.3; COD=1525–2100 mg O₂/dm³, oil=5.7–9.2 mg/dm³, suspended solids=68.4–96.1 mg/dm³. In studies of the technology of physico-electrochemical wastewater purification, zeolite clinoptilolite of the Sokirnitsky deposit was used to load filters [31-33]. It is characterized by the following average indicators: bulk density for the fraction 0.5–8.0 mm=1.1–1.18 kg/dm³, specific surface=20.1–40.8 m²/g, pore size=3.5–4.2 Å.

The efficiency of the processes of coagulation of solid contaminants in an aqueous medium or the oxidation of soluble contaminants in wastewater is determined by a certain current density in the stream of wastewater that flows between the electrodes. It is caused by a certain distance between the electrodes and the establishment of the optimal voltage on the electrodes, as well as the material of the electrodes. To coagulate solid contaminants in wastewater, it is necessary to create a certain current density in electrical devices. Electroblocking of the aquatic environment is caused by a certain distance between the electrodes of the corresponding material and the establishment of the optimal voltage on the electrodes. Therefore, in order to be able to establish and control the current density during electrical sampling of the aqueous medium, a new design of electrical equipment is developed (Fig. 1), which is included in the technological scheme of the laboratory unit (Fig. 2).

5. Improved design of electrical device for wastewater purification

The technology of electrochemical purification of contaminated natural and wastewater is based on the use of electrical energy, which determines the processes of electrocoagulation and electrolysis of aqueous solutions of electrolytes. Chemical transformations in an electrolyte solution occur in electrolyzers or electrolytic baths and include the following brief theoretical information. The processes take place at the electrodes when a constant electric current passes through water. Reactions of cathodic reduction: the release of gaseous hydrogen H₂ due to the decomposition of water and the dis-

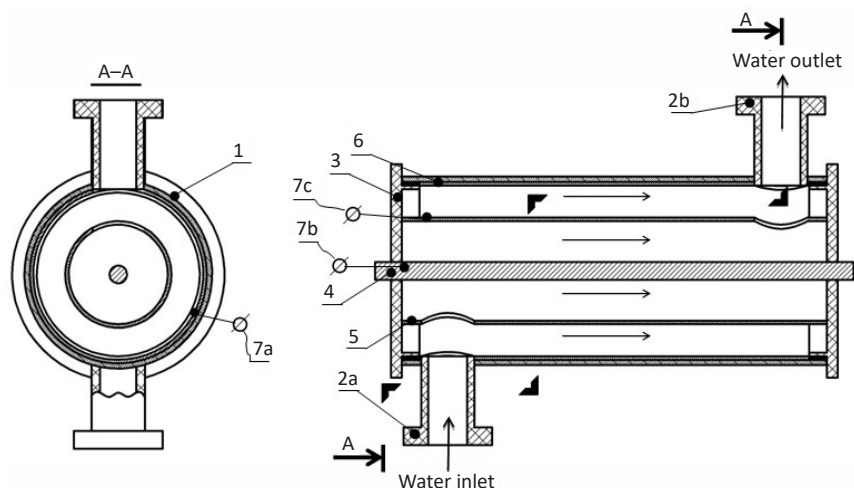

Fig. 1. Schematic diagram of the electrical water purification: 1 – case; 2a, 2b – cylindrical inserts with nozzles; 3 – end caps; 4 – central electrode; 5 – middle electrode; 6 – case electrode; 7a, 7b, 7c – current connection terminals

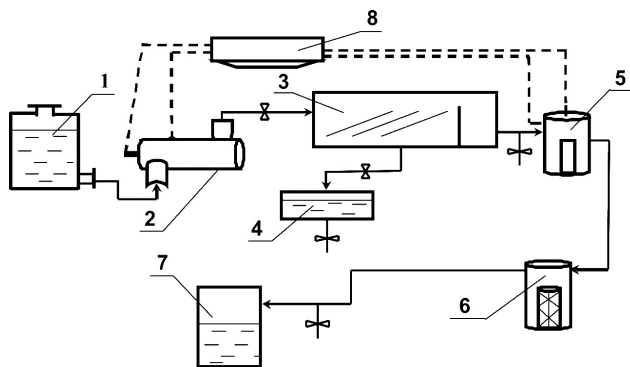

Fig. 2. Scheme of the laboratory unit for wastewater purification: 1 – tanks for wastewater; 2 – electrical device-1; 3 – sedimentation tank with inclined planes; 4 – chamber for collecting sludge from water purification; 5 – electrical device-2; 6 – filter adsorber; 7 – containers for collecting purified water; 8 – current source with rectifier

A new design of an electrical device for processing aqueous media is proposed that provides the ability to control the intensity of wastewater purification and contains a cylindrical body with dielectric material, electrodes and two nozzles for filling and leakage of the aqueous medium. The largest electrode in diameter is adjacent to the housing, connected to an electrical terminal located on the device's body, and other electrical terminals and current leads are located at the end of the device's cover. Moreover, the nozzles for filling by the water environment of the device are a single unit with inserts that are inserted into the housing at the beginning of the device from the bottom for the incoming stream, and the second for the output from the top. The middle electrode of a cylindrical shape is made of insoluble material and has round holes located opposite the inlet and outlet nozzles.

The proposed device accommodates a central electrode 4 mounted permanently on the ends in the caps of the device of a coaxially cylindrical body 1. The electrode 4 can easily be replaced both in diameter and material – iron, stainless, lead or titanium, coated with ruthenium oxides. Two other electrodes in the form of cylinders, of which one inner 6 is placed close to the device body. The middle 5 has cylindrical openings that allow, after the inlet pipe, to divide the water flow into two, which increases the area of its contact of the waste water by 2 times, and, accordingly, for and are placed coaxially of the casing and the central electrode 4.

The studies were carried out in a laboratory unit according to the procedure described below. The technology for wastewater purification is as follows. From the tank, which is located at a height, the wastewater enters the electrocoagula-

tion device of a cylindrical structure, where electrochemical processes take place and enters a thin-layer sedimentation tank in which the suspended ones are separated and enter the sludge tank. Partially purified water from the sinker is further treated in a filter loaded with clinoptilolite zeolite, and then it is recycled or discharged into a natural water body.

6. Research results of a two-stage physico-electrochemical purification technology and establishing the effectiveness of post-purification

At the first stage, the studies were carried out as follows. Compared to the capacity, the wastewater entered the electrical device-1, and then into the sedimentation tank for 1.5 hours in an amount of 30 dm³. Wastewater purification was carried out using a horizontal sedimentation tank with inclined planes (IP). Subsequently, the effluents enter electric device-2, where, under the influence of an electric current ($U=8-12\text{ V}$), electrochemical processes occur in the effluents. From electric device-2, the effluent flows through a filter filled with filter material (clinoptilolite zeolite), where other contaminants are separated from the wastewater during filtration and adsorption, and then the purified water enters the tank of purified water. The purification study was carried out under dynamic conditions, and the wastewater indicators were determined according to the methods [34, 35]. The purification degree from pollution was determined by the formula as the ratio of the difference between the initial concentration of the ingredient C_i and the final C_f to the initial one. The research results are given in Table 2.

Based on the results of laboratory and experimental studies of wastewater purification at the Vodocotekhprom industrial complex, it was found that electrical treatment with a voltage of 12 V in front of a thin-layer sedimentation tank increases the efficiency of suspended separation from 81 to 92.4 %. The degree of wastewater purification at the first stage with electrical treatment to the sedimentation tank due to the separation of suspended is an average of 83.3–96.2 %. With an inclination angle of inclined planes of 30° it is 82.1–88.5 %, 45° – 83.7–89.1 % and 60° – 80.5–95.2 %, respectively.

To increase the efficiency of municipal wastewater purification, at the second stage of research, let's make changes to some parameters of the material technology compared to that used at the first stage. They provide for the electric purification of wastewater after the sedimentation tank in front of the laboratory filter was carried out at 10 V. Also, a parallel filter was added to the purification scheme, which was loaded with a zeolite fraction of 0.5–2 mm. The purification results are shown in Table 3.

Table 2

The results of wastewater purification without and with wastewater purification in electrical equipment-1 before a thin-layer sedimentation tank

Indicators wastewater sample		Indicators of wastewater before purification, mg/dm ³		Electric processing parameters, V	Wastewater indicators after purification, mg/dm ³		Purification degree, %	
		Suspension, mg/m ³	COD, mg O ₂ /dm ³		Suspension	COD, mg O ₂ /dm ³	Suspension	COD, mg O ₂ /dm ³
1	No electrically processed	90,61	151,52	0	11,36	16,56	87,5	89,5
3		120,43	140,03	0	22,14	15,92	81,6	88,6
5	Electrically processed	90,61	151,52	12	8,05	10,85	91,1	92,8
7		120,43	140,03	12	9,12	9,71	92,4	93,1
9		112,35	135,71	12	9,03	8,81	91,9	93,5

Table 3

Indicators of municipal wastewater purification by electrochemical sorption technology

Sample/ Filter	Indicators							
	Before purification			After purification			Purification degree, %	
	Suspension, mg/m ³	pH	COD, mg O ₂ /dm ³	Suspension, mg/m ³	pH	COD, mg O ₂ /dm ³	Suspension	COD
1/I	82,6	7,4	125,7	4,0	7,3	8,5	95,8	93,2
2	87,7	7,5	142,3	4,1	7,4	4,8	95,3	95,9
5	90,5	7,6	151,5	3,2	7,5	5,1	96,5	96,6
7	120,4	7,4	145,3	3,3	7,3	6,1	97,3	95,8
9	112,3	7,5	135,6	3,5	7,4	4,4	96,8	96,7
1/II	82,6	7,4	125,7	3,1	7,3	6,5	96,2	94,8
2	87,7	7,5	142,3	3,7	7,4	5,8	95,8	95,9
5	90,5	7,6	151,5	3,5	7,5	4,3	96,1	97,2
7	120,4	7,4	145,3	3,6	7,3	5,3	97,0	96,4
9	112,3	7,5	135,6	4,5	7,4	4,6	95,9	96,6

Note: I – filter with a fraction of 0.5–1 mm zeolite, II – filter with a fraction of 0.5–2 mm

In the next stage III of the research, wastewater was purified from a communal facility in Ivano-Frankivsk – car wash.

For research, let's also use real wastewater after washing cars of the Ivano-Frankivsk using the technology for purifying oil products, which is described for the second stage of research. The results of wastewater purification from suspensions ones using the previous electrical purification in electrical device-1 in front of a horizontal sedimentation tank with inclined planes from the infrastructural communal facility from the previous electrical treatment are given in Table 4.

one apparatus with the participation of a plate-shaped electrode block. However, the use of such complex electrical appliances leads to difficulties in their maintenance. They occur at constant parameters of the electric treatment regimes of the aquatic environment. Since the content of contaminants in wastewater varies both in terms of specific contaminants and in quantity, it is extremely difficult to achieve a high wastewater purification degree. The proposed technology for the two-stage purification of municipal wastewater in 2 electrical installations of a new design, installed in front of the sedimentation tank and in front of the filter, increases

Table 4

The results of wastewater purification with electrical treatment in front of the sedimentation tank

Wastewater sample	Wastewater indicators before purification, mg/dm ³		Purification, V in I and II electrical devices	Wastewater indicators after purification, mg/dm ³		Purification degree, %	
	Suspensions	Oil products		Suspensions	Oil products	Suspensions	Oil products
1	77.6	5.7	10	5.1	0.7	93.4	87.7
5	85.5	9.2	12	3.2	0.4	96.2	95.6
6	91.3	7.5	14	4.8	0.6	94.7	92.0
7	96.1	8.4	12	2.9	0.4	97.0	94.0
9	68.4	6.1	12	2.5	0.3	96.3	95.1

So, according to the research results on wastewater purification, car washing using the technology of electrochemical wastewater purification is effective, because at a voltage of 12 V in the 1st electric device and the inclination angle of the inclined planes block into a 45 ° thin-layer sedimentation tank, the waste oil separation is 94, 0–95.6 %, and tertiary treatment in the filter with loading of clinoptilolite zeolite with a fraction of 0.5-1.0 mm reduces the suspension content in 96.2–97.0 %.

7. Discussion of the results of laboratory studies of the technology of physical and electrochemical technology

During wastewater purification by the electrochemical method, the processing of the aqueous medium takes place in

the purification degree at the first stage from suspended to 92.4 % (Table 2), and at the second to 97.3 % (Table 3). The developed electrical device (Fig. 2) differs from the known ones in that the device contains three cylindrical electrodes mounted coaxially to the cylindrical body at a certain distance from each other, and accordingly of different diameters. This arrangement of the electrodes creates a different current density on the surfaces of the electrodes, which affects the charge of contaminants and the efficiency of their separation in a sedimentation tank or filter with a loaded zeolite. It is also worth not-

ing that the material of the anodes is different – in the first it is soluble, and in the second insoluble. In addition, the distances between the electrodes are different, which leads to different current densities arising on the electrodes. So in the first there is a process of coagulation of suspended particles by a coagulant formed from a soluble anode, and then an effective flotation process into a thin-layer settler. In the second electrical device, the soluble contaminants of wastewater are oxidized and degraded and treated further – filtering through a filter through a clinoptilolite zeolite of a fraction of 0–2 mm, which is more effective due to its larger surface compared to a fraction of 0–1 mm, is purified. This technology allows to increase the degree of purification by 10–15 % and get a stable water purification process.

The research results of the wastewater purification of a car wash, according to the proposed technology of electro-

chemical treatment of wastewater in front of a sedimentation tank, followed by filtration through clinoptilolite zeolite, are as follows. It has been established that it is effective, since at a voltage of 12 V and an inclination angle of the block of inclined planes into a thin-layer sedimentation tank of 45°, the separation of oil products in wastewater increases by 94.0–95.6 %. Post-purification in the filter with loading of clinoptilolite zeolite with a fraction of 0.5–2.0 mm increases the purification degree from suspensions in 96.2–97.0 %, which can be explained by a larger specific surface of the filter load.

So, according to the research results, the technology of electrochemical wastewater purification with subsequent filtration through zeolite clinoptilolite is effective. Filter loading with zeolite clinoptilolite reduces the content of soluble contaminants in the effluent, probably due to adsorption processes. Local wastewater purification will generally reduce the load on city-wide treatment facilities and the discharge of pollution into water resources.

The proposed technology allows to increase the purification degree by 10–15 % and obtain a stable water purification process. In addition, a technology has been developed that allows the automation of the water purification process and the creation of local, autonomous or mobile water purification plants that can effectively operate at different ambient temperatures. This means that the scientifically-applied result of the electric wastewater purification at two stages (in front of a sedimentation tank and a filter) in electrical installations of a new design, from a practical point of view, determines the conditions for using this technology and electrical devices from the rational parameters of water purification. Thus, the applied aspect

of using the obtained scientific result is the possibility of improving the technological process of water purification. This constitutes the prerequisites for the transfer of received technological solutions.

This technology allows to increase the wastewater purification degree and is interesting from a theoretical point of view, since in subsequent studies it should be established which content of an individual component or structural element of an electrical device affects the degree of wastewater purification more.

A prospect for the development of this research may be the development of a technology for the treatment of sludge from water purification directly after the process of separating contaminants in a sedimentation tank and filter in a compact device to obtain a granular processing product.

8. Conclusions

1. An electrical device, which includes three electrodes, of which the middle one is soluble in the first stage and insoluble in the second, and has openings for dividing the water stream into two, increases the wastewater purification degree in the range of 10–15 %.

2. The technology of two-stage purification of municipal wastewater is effective, since the purification degree from suspensions is 93.4–97.0 %. It is found that the maximum degree of wastewater purification from car washes using physico-electrochemical technology from suspensions was 95.3–97.2 % for double electrical purification in front of the sedimentation tank and filter with a loading of 0–2 mm clinoptilolite zeolite fraction.

References

- Aljouboury, D. A. D. A., Palaniandy, P., Abdul Aziz, H. B., Feroz, S. (2017). Treatment of petroleum wastewater by conventional and new technologies a review. *Global NEST Journal*, 19 (3), 439–452. doi: <https://doi.org/10.30955/gnj.002239>
- Radelyuk, I., Tussupova, K., Zhapargazinova, K., Yelubay, M., Persson, M. (2019). Pitfalls of Wastewater Treatment in Oil Refinery Enterprises in Kazakhstan – A System Approach. *Sustainability*, 11 (6), 1618. doi: <https://doi.org/10.3390/su11061618>
- WWAP (United Nations World Water Assessment Programme) (2017). The United Nations World Water Development Report 2017. Wastewater: The Untapped Resource. Paris, UNESCO. Available at: https://www.unido.org/sites/default/files/2017-03/UN_World_Water_Development_Report_-_Full_0.pdf
- Prokopenko, O. (Ed.) (2018). *Statistical Yearbook. Environment of Ukraine 2017*. State Statistics Service of Ukraine. Kyiv, 225.
- Blinnikova, O. (Ed.) (2018). *Statystychnyi shchorichnyk Ivano-Frankivskoi oblasti za 2017*. Holovne upravlinnia statystyky v Ivano-Frankivskiy oblasti. Ivano-Frankivsk.
- Cheliadyn, L. (2018). *Ekotekhnolohiya promyslovykh proektiv u rehioni*. Ivano-Frankivsk: NTUNH, 254.
- Statystychnyi zbirnyk «Dovkillia Ivano-Frankivshchyny» (2018). Ivano-Frankivsk, 165.
- Zapolskyi, A. K., Mishkova-Klymenko, N. A., Astrelin, I. M. et. al. (2000). *Fyzyko-khimichni osnovy tekhnolohiyi ochyshchennia stichnykh vod*. Kyiv: Libra, 552.
- Tchobanoglous, G., Burton, F. L., Stensel, H. D. (2003). *Wastewater engineering: treatment and reuse*. Inc. McGraw-Hill Education, 1819.
- Guo, Z., Sun, Y., Pan, S.-Y., Chiang, P.-C. (2019). Integration of Green Energy and Advanced Energy-Efficient Technologies for Municipal Wastewater Treatment Plants. *International Journal of Environmental Research and Public Health*, 16 (7), 1282. doi: <https://doi.org/10.3390/ijerph16071282>
- Christensen, M. L., Keiding, K., Nielsen, P. H., Jørgensen, M. K. (2015). Dewatering in biological wastewater treatment: A review. *Water Research*, 82, 14–24. doi: <https://doi.org/10.1016/j.watres.2015.04.019>
- Yavorskiy, V. T., Chelyadyn, L. I. (1986). *Ochistka plastovykh vod protsessu podzemnoy vyplavki sery ot serovodoroda i sul'fidov metalla*. Zhurnal prikladnoy himii, 8, 1761–1766.
- Yavorskiy, V. T., Chelyadyn, L. I., Hitsyak, P. B., Mel'nik, V. F., Pavlyuk, D. M., Vorona, L. A. (1997). *Ochistka sul'fidnykh plastovykh vod*. Himiya i tehnolohiya vody, 9 (5), 462–464.
- Cheliadyn, L. I., Hryhorchuk, L. I., Cheliadyn, V. L., Bohoslavets, M. M. (2013). Methods and equipment reduce of effluents water pollution from oil and gas facilities. *Prospecting and Development of Oil and Gas Fields*, 2 (47), 145–151. Available at: <http://rrngr.nung.edu.ua/index.php/rrngr/article/view/410>

15. Wei, X., Zhang, S., Han, Y., Wolfe, F. A. (2019). Treatment of petrochemical wastewater and produced water from oil and gas. *Water Environment Research*, 91 (10), 1025–1033. doi: <https://doi.org/10.1002/wer.1172>
16. Jamaly, S., Giwa, A., Hasan, S. W. (2015). Recent improvements in oily wastewater treatment: Progress, challenges, and future opportunities. *Journal of Environmental Sciences*, 37, 15–30. doi: <https://doi.org/10.1016/j.jes.2015.04.011>
17. Cheliadin, L. I., Hryhorchuk, L. I., Cheliadin, V. L. (2009). Obladnannia ochyshchennia stichnykh vod i yoho vplyv na hidrosfernyi faktor ekolohichnoi bezpeky ob'ektu. *Ekolohichna bezpeka*, 1 (5). 20–25. Available at: [http://www.kdu.edu.ua/EKB_jurnal/2009_1\(5\)/20.PDF](http://www.kdu.edu.ua/EKB_jurnal/2009_1(5)/20.PDF)
18. Wang, S., Peng, Y. (2010). Natural zeolites as effective adsorbents in water and wastewater treatment. *Chemical Engineering Journal*, 156 (1), 11–24. doi: <https://doi.org/10.1016/j.cej.2009.10.029>
19. Chelyadyn, V. L., Bogoslavets, M. M., Chelyadyn, L. I. (2016). Processing technologies of technogenic waste into filter media for sewage treatment of industrial objects. *Water Supply and Wastewater Removal*, 15–25.
20. Cheliadyn, L. I., Lihots'kyi, M. V., Cheliadyn, V. L., Ruzhytskyi, B. Ya. (2005). Pat. No. 5740 UA. Thin-layer sump for purification of waters. No. 20040806748; declared: 12.08.2004; published: 15.03.2005, Bul. No. 3.
21. Lukashevich, O. D. (2005). Ekologicheskie aspekty ochistki vody fil'trovaniem. *Ekologiya promyshlennogo proizvodstva*, 2, 31–33.
22. Tarasevich, Y. I., Trifonov, M. Y., Ostapenko, V. T., Kulishenko, E., Kravchenko, T. B. (2016). The use of adsorption-active additions of some natural minerals for raising the quality of coagulation purification of natural water. *Journal of Water Chemistry and Technology*, 38 (6), 327–330. doi: <https://doi.org/10.3103/s1063455x16060047>
23. Zhang, J. K., Jiang, Y., Yuan, Y. X. (2011). Comparative Study on the Mn²⁺ Removing Performance of Several Filters. *Advanced Materials Research*, 415–417, 100–105. doi: <https://doi.org/10.4028/www.scientific.net/amr.415-417.100>
24. Bohuslavets, M. M., Cheliadyn, L. I., Drahomyretskyi, Y. M., Cheliadyn, V. L., Skrobach, M. R. (2007). Pat. No. 27668 UA. Filter-adsorber. No. u200707240; declared: 27.06.2007; published: 12.11.2007.
25. Cheliadyn, L. I., Mandryk, O. M., Cheliadyn, V. L., Nestor, V. P. (2010). Pat. No. 48053 UA. Universal installation of purification of waste water and processing slime. No. u200907209; declared: 10.07.2009; published: 10.03.2010, Bul. No. 5.
26. Rogov, V. M., Filipchuk, V. L. (1989). *Elektro-himicheskaya tehnologiya izmeneniy svoystv vody*. Lviv, 126.
27. Melnyk, E. S., Pliatsuk, L. Ye. (2009). Optymizatsiya protsesu elektrokoahuliatsiyi stichnykh vod halvanichnoho vyrobnytstva. *Visnyk Sums'koho derzhavnogo universytetu. Seriya tekhnichnykh nauk*, 1, 200–204.
28. Zhitenyov, B. N., Korbulaeva, E. A., Zhitenyova, N. S. (2014). Destruction of dye in the electrolyzer with insoluble electrodes. *Vestnik Brestskogo gosudarstvennogo tehnikeskogo universiteta*, 2, 67–69. Available at: <https://rep.bstu.by/xmlui/bitstream/handle/data/2512/67-69.pdf>
29. Golovanchikov, A. B., Sivolobov, M. M., Dahina, G. L., Kosenkova, I. Yu. (1992). Pat. No. 2039710 RF. Elektrokoagulyator dlya ochistki vody. declared: 20.04.1992; published: 20.07.1995. Available at: <http://www.freepatent.ru/patents/2039710>
30. Pliatsuk, L. D., Melnyk, O. S., Kovalenko, V. L. (2009). Pat. No. 91631 UA. Electrocoagulator for waste water treatment. No. a200900337; declared: 19.01.2009; published: 10.08.2010, Bul. No. 15.
31. Andrieev, A. M., Dmytrenko, M. A., Minaiev, Yu. P., Levin, R. Ye. (2005). Pat. No. 9390 UA. A mechanism for the electrochemical treatment of water. No. u200502956; declared: 31.03.2005; published: 15.09.2005, Bul. No. 9.
32. Sabadash, V. (2013). Application of natural and synthetic zeolites for adsorption treatment of wastewaters. *Development trends of the modern technical sciences*. B & M Publishing, San Francisco, California, 42–49.
33. Sprynskyy, M., Buszewski, B., Terzyk, A. P., Namieśnik, J. (2006). Study of the selection mechanism of heavy metal (Pb²⁺, Cu²⁺, Ni²⁺, and Cd²⁺) adsorption on clinoptilolite. *Journal of Colloid and Interface Science*, 304 (1), 21–28. doi: <https://doi.org/10.1016/j.jcis.2006.07.068>
34. DSTU ISO 6060:2003. *Yakist vody. Vyznachennia khimichnoi potreby v kysni (ISO 6060:1989, IDT)* (2004). Kyiv.
35. Lur'e, Yu. Yu. (1984). *Analiticheskaya himiya promyshlennykh stochnykh vod*. Moscow, 448.