

18. Eljamal, O., Jinno, K., Hosokawa, T. (2008). A mathematical model of biological clogging of soil-sawdust media. *Journal of Environmental Hydrology*, 16 (4), 1–12. Available at: [https://www.researchgate.net/publication/281260984\\_A\\_mathematical\\_model\\_of\\_biological\\_clogging\\_of\\_soil-sawdust\\_media](https://www.researchgate.net/publication/281260984_A_mathematical_model_of_biological_clogging_of_soil-sawdust_media)
19. Sergienko, I. V., Skopetskiy, V. V., Deyneka, V. S. (1991). *Matematicheskoe modelirovanie i issledovanie protsessov v neodnorodnyh sredah*. Kyiv: Naukova dumka, 431.
20. Vlasyuk, A. P., Martynuk, P. M., Fursovych, O. R. (2009). Numerical solution of a one-dimensional problem of filtration consolidation of saline soils in a nonisothermal regime. *Journal of Mathematical Sciences*, 160 (4), 525–535. doi: <https://doi.org/10.1007/s10958-009-9518-8>
21. Bölter, M., Bloem, J., Meiners, K., Möller, R. (2005). Enumeration and biovolume determination of microbial cells. *Microbiological Methods for Assessing Soil Quality*, 93–113. doi: <https://doi.org/10.1079/9780851990989.0093>

*This paper reports a study on the application of aluminum sulfate solution, modified by the magnetic field and electrocoagulation, in the processes of drinking water preparation. The modification of the coagulant solution makes it possible to intensify water purification processes, to reduce reagent consumption by 25–30 %. It has been found that a dose of the modified aluminum sulfate solution of 28–30 mg/dm<sup>3</sup> improves the efficiency of removal of suspended substances and coloration by 35–40 %. The dosage of the conventional reagent solution was 40 mg/dm<sup>3</sup> while reaching the same purification parameters.*

*Modifying a solution of aluminum sulfate with the magnetic field and electrocoagulation increases the hydraulic size of the coagulated suspension. A change in the hydraulic size in the suspension has been studied at different periods of the year. In winter, when treating water with the modified aluminum sulfate solution, there a decrease in the suspension content whose hydraulic size is 0.1 mm/s and less, from 89 % to 22 %. In this case, the content of suspended substances at settling decreases from 8.5–12.5 mg/dm<sup>3</sup> to 5.6–8.3 mg/dm<sup>3</sup>. In spring, when using the modified coagulant solution, the content of suspension whose size is 0.1 mm/s and less decreased from 55 % to 15 %. In summer, there is an increase in the content of suspension whose size is 0.3–0.5 mm, from 58 % (a conventional reagent solution) to 66 % (the modified reagent solution). This indicates an intensification of the coagulation of impurities and the clarification of water.*

*The experimental data testify to an increase in the effectiveness of discoloration of natural low-turbid colored water to 63.3–63.9 % for the modified reagent solution at 45.5 % for a conventional reagent solution.*

*A change in the bacteriological parameters has been determined: the effectiveness of the decrease in a microbial number grows from 11.6–18.7 % to 18.6–25.1 %. In terms of a coli-index, the efficiency of purification grows from 16.6–23.1 % to 23.0–29.5 %*

*Keywords: drinking water quality, modification of reagent solution, coagulation, aluminum sulfate, hydraulic size, coloration, suspended substances, water clarification, magnetic field, anode-dissolved iron*

UDC 628.16

DOI: 10.15587/1729-4061.2020.210096

# APPLYING A MODIFIED ALUMINUM SULFATE SOLUTION IN THE PROCESSES OF DRINKING WATER PREPARATION

**S. Dushkin**

PhD, Associate Professor

Department of Applied Mechanics and  
Environmental Protection TechnologiesNational University of Civil Defence of Ukraine  
Chernyshevskaya str., 94, Kharkiv, Ukraine, 61023

E-mail: d.akass@ukr.net

**T. Shevchenko**

PhD, Associate Professor

Department of Water  
and Wastewater EngineeringO. M. Beketov National University  
of Urban Economy in KharkivMarshala Bazhanova str., 17,  
Kharkiv, Ukraine, 61002

E-mail: Tamara.Shevchenko@kname.edu.ua

Received date 23.07.2020

Accepted date 14.08.2020

Published date 25.08.2020

Copyright © 2020, S. Dushkin, T. Shevchenko

This is an open access article under the CC BY license

<http://creativecommons.org/licenses/by/4.0>

## 1. Introduction

The purification of water from the surface sources of water supply, used to provide drinking needs, from coarsely-dispersed, colloidal, and other contaminants, mostly employs the physical-chemical technology. This technology includes

the processes of settling and filtration, which are important elements of water supply systems in the preparation of drinking water [1, 2].

One of the most common methods of water purification from coarsely-dispersed and colloidal contaminants is the method of water treatment by coagulants. However, under

the adverse conditions of coagulation, such as insufficient alkalinity, high coloration, and low water temperature, the reagent consumption is quite significant. Therefore, this method needs to be improved, namely: to increase the rate of the formation of coagulated suspension and its deposition.

An analysis of existing methods to improve the operational efficiency of treatment plants in the preparation of drinking water reveals that there are new methods being developed to intensify the operation of these facilities. The most promising are those methods that are related to the modernization of existing, and the development of new, methods and designs of water treatment machines [3, 4].

The preparation of drinking water from surface sources in winter and during a flood period typically involves the larger dosage of reagents because the low temperature of water leads to the deterioration of a coagulation process. This is also contributed to by the insufficient water alkalinity during a flood. However, the use of larger doses of reagents is not always reasonable and leads to a higher load on treatment facilities. In particular, the larger reagent dosage causes the formation of small-size suspension, which is very slowly deposited in the sediment yards and subsequently leads to the rapid clogging of the interporous space of quick filters. Therefore, objective difficulties arise while improving the efficiency of a coagulation process. These difficulties are due to the complication of the process of coagulation of impurities under conditions of low temperature, the high coloration, and insufficient alkalinity of natural water in winter and during the spring flood.

Therefore, there is a need to increase the efficiency of the process of coagulating impurities of natural water during different seasons when applying new technological purification techniques.

An analysis of the design and operational materials for the water supply treatment facilities has allowed us to establish that the following technological schemes of water clarification and discoloration [4, 5] are the most widespread:

- a scheme implying the two-stage treatment of water with coagulation of impurities in the free volume (reaction chambers, sedimentation yards, filters);
- a scheme involving the two-stage treatment of water with coagulation of impurities in the limited volume of the suspended sediment (a clarifier with suspended sediment, filters);
- a scheme with the one-stage water treatment and the use of contact coagulation.

The technological schemes for the purification of natural water for drinking water supply do not always yield the necessary quality of water purification and require significant reagent consumption. Therefore, the development and substantiation of technological schemes for drinking water preparation are one of the important tasks in the intensification of operation of water supply facilities.

---

## 2. Literature review and problem statement

---

The application of a new natural mineral coagulant, instead of the generally accepted aluminum sulfate, is considered in work [6]. The natural material contains the following components:  $\text{SiO}_2$  – 75–80 %,  $\text{Al}_2\text{O}_3$  – 18–22 %,  $\text{Fe}_2\text{O}_3$  – 0.5–1 %,  $\text{H}_2\text{O}$  – 0.2–0.5 %,  $\text{CaSO}_4$  – 0.3–0.5 %,  $\text{CaCO}_3$  – 0.12–0.8 %. The use of a mineral coagulant of the natural origin makes it possible to abandon the application of chemical coagulants and flocculants and reduces chemical pollution of drinking water. The authors determined the optimum tech-

nological parameters of treatment facilities operation in case of using a natural mineral coagulant. However, the application of the specified method at water treatment plants is limited because of the presence or absence of a natural material's deposit, which could be applied instead of chemical reagents.

Paper [7] analyzed the application of new processes to intensify the operation of water treatment facilities. The expediency of using a non-thermal plasma, the stirring reactors with partitions, sonication, twisting a flux, the application of rotating plates, ultraviolet irradiation, microwaves processing, ozone flotation, inkjet oscillatory devices was considered taking into consideration several aspects. These aspects include capital expenditure, full operational cost, performance, sustainability, logistical costs, a possibility for adaptation by other industries, novelty, and so on. Each of the above methods requires further study, experimental research, and the consideration of individual components of an object at which any method is introduced.

Study [8] investigated, as an additive, monodispersed silica, synthesized by the Stober method, in the ultra-low concentrations for the synthesis of organo-inorganic membranes based on polyester sulfone for the potential use in water treatment. The study results showed that the polyester sulfone (PES) membrane, alloyed with monodispersed silica, has improved characteristics. The hydrophilicity of the modified membranes was also increased due to the high affinity of  $\text{SiO}_2$  nanoparticles to water, which resulted in higher permeability. However, in the interval of high concentrations of the  $\text{SiO}_2$  nano-particles the permeability of the modified membranes decreases due to the clogging of pores and a change in the macro voids in the membrane sublayer. At the same time, the selectivity of the modified membranes was improved, which is an indicator of a narrower size of pores. The optimum permeability was attained with the addition of 0.30 % of nano-silica. The application of the modified membranes in water treatment is a promising method but high capital expenditures for the construction of membrane units and the need for preliminary fine mechanical purification lead to an increase in the cost of water purification.

The impact of a magnetic field on the process of reduction in scale formation in hydraulic systems is considered in paper [9]. The use of harmful chemicals to reduce scale, while being effective, brings more harm than good as it makes water unsuitable for human consumption and causes an environmental imbalance. Magnetic processing devices against scale offer a cleaner solution to solve this problem. However, data on the magnetic treatment of water are very different and do not yield a consensus on the operational mode of magnetic devices.

One of the basic requirements for water purification plants is the reliability and continuity of their work. The latter to a large extent can be achieved by using in water purification processes of the modified reagent solutions, and, in particular, for the preparation of drinking water – the modified coagulant solution – aluminum sulfate. The specified method makes it possible to improve the quality of water purification, in terms of the suspended substances and coloration, by, on average, 25–30 %, to reduce the dosage of a coagulant by an average of 20–25 %. It is also possible to improve the productivity of treatment facilities by an average of 15–20 % and reduce the cost of water purification. The latter, in turn, would reduce capital expenditures for the construction of treatment facilities in water supply systems and improve the anthropogenic-environmental safety in drinking water purification processes [10, 11].

The mechanism of influence of the modified reagent solutions on water purification processes can be explained by a definite factor: the overlay of a magnetic field on aqueous solutions. An outer magnetic field overlap changes the structure of aqueous solutions and creates conditions for the formation of ion associations of the submicroscopic and colloidal degree of dispersiveness [11, 12]. In turn, the ionic associates, which emerged under the influence of a magnetic field, are the embryos of a new phase of the submicroscopic and colloidal stages of dispersiveness and, upon their stabilization, perform the role of additional coagulation centers. The stabilization of ion associates is carried out with the help of anode-dissolved iron [11].

It was established that the use of the modified coagulant solution for water purification promotes the formation of denser shielded films that slow the diffusion of counter water flows and compounds, formed during coagulation, through the shielding hydrated films.

When using the modified coagulant solution, the formation of the shielding films at the surface of the coagulated impurities occurs slower, while the dehydration of the hydrated structured complexes, formed during water purification, accelerates.

The latter is confirmed by the results of the relaxation timing measurement  $T_1$  by a method of nuclear magnetic resonance (NMR) in the coagulation process of impurities with the regular and modified solutions of aluminum sulfate (Fig. 1) [13]. When a magnetic field acts on a coagulant solution, there is a disruption of the thermodynamic equilibrium in the solution. When the magnetic field acts no longer, the hydrodynamic system must again reach the equilibrium. The process of establishing an equilibrium in the hydrodynamic system is called the relaxation. The time over which the equilibrium sets in the system is called the relaxation time. The relaxation measurements based on the NMR method makes it possible to analyze the dynamics of molecules movement, determine the coefficient of self-diffusion, to investigate the processes of hydration, as well as other phenomena that occur in water-dispersed systems [14].

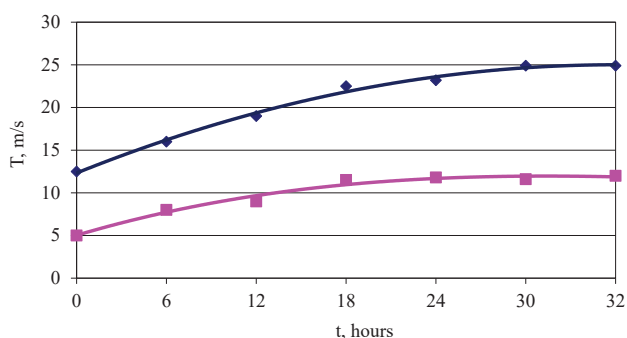

Fig. 1. Results of the relaxation time  $T_1$  measurement in the coagulation process of impurities with the conventional and modified aluminum sulfate solutions:  $\blacklozenge$  – the modified coagulant solution;  $\blacksquare$  – a conventional coagulant solution

The character of the nuclear relaxation dependence  $T_1/f(t)$  is due to the mechanism of impurities coagulation. The first section of the curves in Fig. 1 is characterized by the time of relaxation, caused probably by the release of water molecules from the associated state as a result of the increase in the specific surface of the coagulation structure. In the second section  $T_1/f(t)$ , the relaxation time slows down sharply, which corresponds to the intensive formation of coagulation structures. Subsequently, the coagulation structure changes slightly – the time of relaxation does not significantly change.

Table 1 [13] gives the results of relaxation time measurements of the modified and activated aluminum sulfate coagulant solution that show the time interval during which the nonequilibrium closed macroscopic system enters equilibrium.

Table 1

A change in the relaxation time of the conventional and modified solutions of aluminum sulfate reagents

Type of an aluminum sulfate reagent solution	Relaxation time $T_1$ , m/s	Change $T_1$ , %
Conventional	1,033–1,035	–
Modified	1,108–1,179	7.2–14.1

The analysis of experimental data indicates that the modification of the coagulant solution leads to a more substantial violation of the dynamic equilibrium of the water-dispersed system. Therefore, it creates more favorable conditions for the formation of ion associates – the embryos of a new phase of the submicroscopic and colloidal stage of dispersiveness, which perform the role of additional coagulation centers in water purification [7, 12].

The use of modified coagulant solutions makes it possible to prolong the relaxation time  $T_1$  in the process of impurities coagulation. The latter is probably caused by the presence of additional coagulation centers and, consequently, a more significant violation of the dynamic equilibrium in the water-dispersed system in the process of water purification.

Experimental data acquired when using an NMR method indicate that the active centers of the colloidal stage of dispersiveness intensify the processes of water purification. These active centers, formed in a solution of aluminum sulfate under the action of a magnetic field, after stabilizing them by anode-dissolved iron, act as the additional centers of coagulation.

The theory of the formation of ion associates during the magnetic treatment of a solution is substantiated in works [15–17].

A coagulant solution is activated in a special device, which involves the formation of ion associates resulting from magnetic treatment and binding them with the anode-dissolved iron [18].

The problematic issue is the study of the effect of the modified aluminum sulfate solution on the processes of clarification and discoloration of natural waters in surface sources. Constant changes in the qualitative characteristics of natural water, such as temperature, coloration, the content of the suspended substance in different seasons, require constant changes in the technological process of purification. Therefore, it is important to investigate the influence of the aluminum sulfate solution, modified with the magnetic field and electrocoagulation, on the qualitative indexes of purified water. It is also necessary to compare the amount of the formed coagulated suspended substance in terms of the hydraulic size when using the modified and conventional coagulant solutions.

One of the important parameters of drinking water purification is its bacteriological safety. The effect of a modified aluminum sulfate solution on indicators such as the general microbial number and a coli-index has not been investigated up to now. Therefore, these issues require further research.

### 3. The aim and objectives of the study

The aim of this work is to establish the feasibility of applying a modified coagulant aluminum sulfate solution in

the preparation of drinking water. To accomplish the aim, the following tasks have been set:

- to experimentally investigate the effect of the modified solution of aluminum sulfate coagulant on the hydraulic size of the coagulated suspended substance;
- to examine the effect of the content of suspended substances in starting water on the effectiveness of clarification when using the modified solution of aluminum sulfate coagulant;
- to establish the possibility of reducing the estimation dosage of the reagent when using the modified solution of aluminum sulfate coagulant;
- to investigate the impact of the modified solutions of aluminum sulfate coagulant on a change in the bacterial indicators of water.

#### 4. Materials and methods to study the application of the modified solution of aluminum sulfate coagulant in the preparation of drinking water

The study on the intensification of water supply facilities' operation using the modified solution of aluminum sulfate coagulant in the preparation of drinking water was performed under laboratory conditions. In addition, a series of experiments were carried out at a pilot installation, located at the water treatment facilities.

A scheme of the chain of machines for the activation of a coagulant solution is shown in Fig. 2.

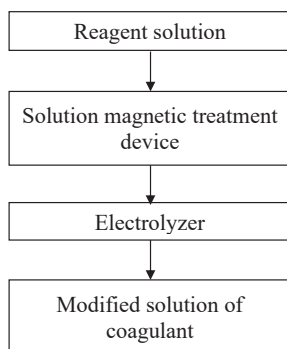

Fig. 2. Scheme of the chain of machines for the activation of coagulant solutions

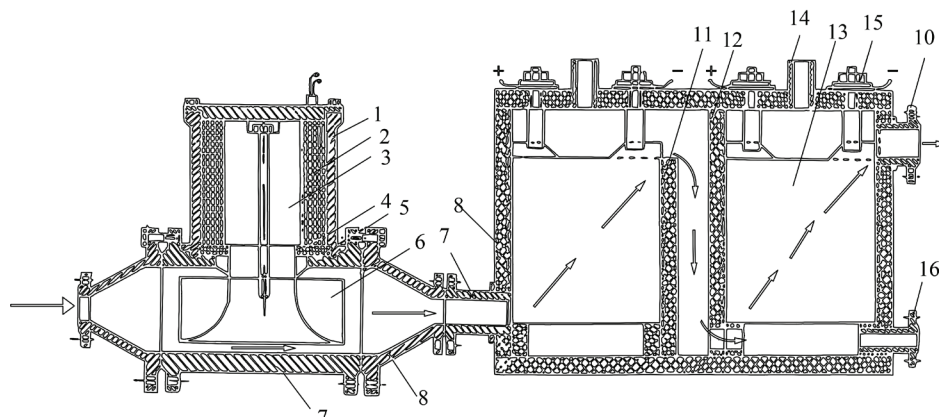

Fig. 3. Modifier for the activation of reagent solutions:

- 1 – electromagnetic system casing; 2 – coil; 3 – core; 4 – diamagnetic plate; 5 – waterproof pads; 6 – pole nozzle; 7 – magnetic circuit body; 8 – coupler; 9 – electric coagulator body; 10 – inlet and outlet branch pipe; 11, 12 – partitions for discharge and passing; 13 – plates; 14 – fitting for hydrogen discharge; 15 – connector terminal; 16 – drain nozzle

A modifier consists of two consistently connected devices: a magnetic activator and an electric coagulator. A reagent solution, when passing a working gap between a magnetic circuit casing and a pole nozzle, is exposed to a magnetic field, generated by an electromagnetic coil. Next, the solution enters the electric coagulator where it is saturated with anode-dissolved iron. A modifier to activate a coagulant solution is shown in Fig. 3.

The reagent modifier is installed on a reagent pipe before feeding a coagulant solution to a mixer.

This paper considers the method of improving the operational efficiency of the treatment facilities for a water supply system in the preparation of drinking water by using the modified solution of aluminum sulfate coagulant.

The qualitative characteristics of water from the examined water supply sources are given in Table 2. We examined the samples of water from the river Seversky Donets (Kharkiv oblast) and model samples (tap water introduced with a clay extraction).

The study was conducted during the winter period of 2017 and the spring and summer periods of 2018. A 10 % aluminum sulfate solution was used as a reagent. Based on the initial characteristics of the treated water, the following dosage of the reagent was established: 38–40 mg/dm<sup>3</sup> for the conventional aluminum sulfate solution, and 28–30 mg/dm<sup>3</sup> for the modified coagulant solution.

The main accepted technological criterion of the efficiency of using the modified solution of aluminum sulfate coagulant is the residual content of suspended substances in the clarified water. It is this indicator that is one of the main parameters that characterize both the operation of treatment facilities within a water supply system in general and of separate structures such as settling ponds, filters, etc.

The coefficient of an increase in water purification efficiency ( $K$ ) was determined from ratio (1):

$$K = \frac{D_0}{D_m}, \quad (1)$$

where  $D_0$  is the residual content of suspended substances in clarified water (the optical density of suspended substance in a sample) when treated with a conventional reagent solution, mg/dm<sup>3</sup>;  $D_m$  is the residual content of suspended substances in clarified water (the optical density of suspended substance in a sample) when treating water with a modified coagulant solution, mg/dm<sup>3</sup>.

Table 2

Qualitative characteristic of the examined water supply sources

Study period	Temperature, °C	Suspended substances, mg/dm <sup>3</sup>	Coloration, degrees PCS*	pH	General hardness, mol/cm <sup>3</sup>	Alkalinity, mol/dm <sup>3</sup>
Water samples from the river Seversky Donets						
Winter						
January	0.5–1.1	8.5–10.4	34–35	7.6–7.9	3.35–3.65	3.1–3.3
February	0.5–2.6	8.7–12.5	35–42	7.5–7.7	3.65–3.80	3.3–3.5
Spring						
March	2.5–6.5	10.5–14.8	35–42	7.2–7.5	2.95–3.25	2.3–2.8
April	2.5–9.5	11.3–16.5	41–53	7.4–7.6	2.90–3.15	2.7–3.1
Summer						
June	17.5–23.6	11.2–22.3	45–65	7.3–7.7	3.95–4.10	2.6–3.1
July	22.4–23.8	17.4–24.3	55–70	7.5–7.7	3.75–4.05	2.4–2.7
August	22.3–25.3	16.5–38.5	55–85	7.2–7.6	3.95–4.20	2.5–2.8
Autumn						
September	17.3–19.5	17.2–41.3	47–65	7.7–7.9	2.95–3.15	2.5–2.7
October	10.3–17.6	14.6–41.6	50–65	7.5–7.9	2.95–3.15	2.6–3.15
Model water						
2017–2018	1.1–25.4	25–500	20–100	7.2–7.5	4.35–4.65	2.55–2.85

Note: PCS\* – platinum-cobalt scale

The influence of the modified coagulant solution on the hydraulic size of the coagulated suspended substance, which settles at a speed of 1.2 mm/s and 0.2 mm/s and faster, was determined from ratio (2):

$$E = \frac{E_M}{E_0} \cdot 100\%, \tag{2}$$

where  $E$  is the effectiveness of the impact of the modified coagulant solution, %;  $E_M$  is the percentage of the suspended substance, settled in the water, treated with the modified coagulant solution, %;  $E_0$  is the percent of the suspended substance, settled in the water, at regular coagulation, %.

During the study of drinking water purification involving the modified aluminum sulfate solution, the following aspects were examined:

- 1) the influence of the modified solution of aluminum sulfate coagulant on the hydraulic size of the coagulated suspended substance;
- 2) the influence of the content of suspended substances in starting water on the efficiency of clarification when applying the modified solution of aluminum sulfate coagulant;
- 3) the reduction in the estimated doses of a reagent when using the modified solution of aluminum sulfate coagulant;
- 4) the influence of the modified solutions of aluminum sulfate coagulant on a change in the bacterial indicators of water.

### 5. Studying the application of the modified solution of aluminum sulfate coagulant in the preparation of drinking water

#### 5.1. The influence of the modified solution of aluminum sulfate coagulant on the hydraulic size of the coagulated suspended substance

The magnitude of the hydraulic size of the coagulated suspended substance is one of the indicators of the operation of sedimentation ponds, clarifiers with suspended sediment, and other water cleaning facilities. The rapid and complete separa-

tion of a heterogeneous system, which natural water is, depends to a certain extent on the hydraulic size of the suspended substance formed during water treatment with coagulants.

Using a modified coagulant solution for water purification makes it possible to increase the hydraulic size of the coagulated suspended substance and thereby to intensify the processes of water clarification. Treating water with a modified coagulant solution increases the hydraulic size of the coagulated suspended substance, which leads to the faster clarification of water in a sediment pond. When treating water with a conventional coagulant solution (Fig. 4) in winter, a sediment pond contains mainly small suspended substances that are difficult to remove (about 85%; 0.1 mm/s and less). These small suspended substances are removed along with the clarified water. A suspended substance whose hydraulic size is 0.2 mm/s and larger accounts for about 15%.

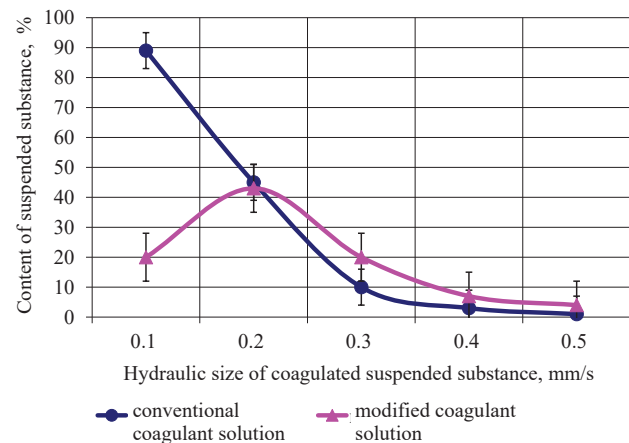

Fig. 4. Effect of the modified solution Al<sub>2</sub>(SO<sub>4</sub>)<sub>3</sub> on the hydraulic size of the coagulated suspended substance in the winter period

Treating water with a modified solution of aluminum sulfate coagulant decreases the content of the smallest sus-

pended substance (up to 22 %), thus increasing the content of suspended substances, detained by a sediment pond (up to 34 %) and improving the quality of the clarified water.

The effect of the modified solution  $Al_2(SO_4)_3$  on the hydraulic size of the coagulated suspended substance in the spring period is shown in Fig. 5. During the spring flood, the coagulation process improves due to the rise of water temperature in a source.

The study that had been conducted in summer (Fig. 6) showed that the amount of small suspended substances (0.1 mm/s and less) is incomparably lower compared to the winter period and a flood. At the same time, there is a predomination of the suspended substances with a hydraulic size of 0.2 mm/s. The content of the suspended substance whose size is 0.3–0.5 mm/s is 58 % (a conventional reagent solution) and 66 % (the modified reagent solution).

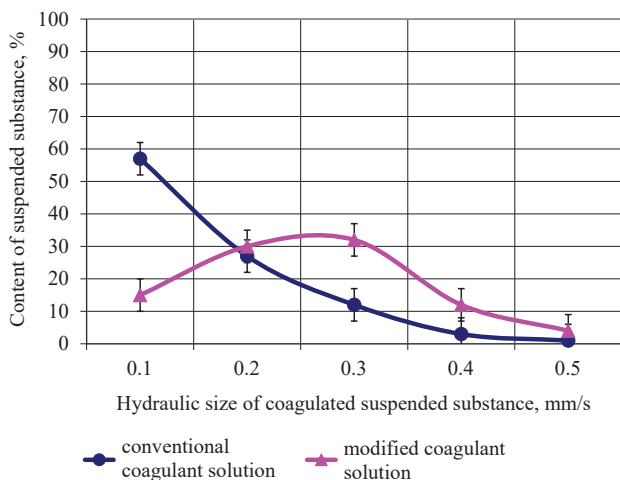

Fig. 5. Effect of the modified solution  $Al_2(SO_4)_3$  on the hydraulic size of the coagulated suspended substance in the spring period

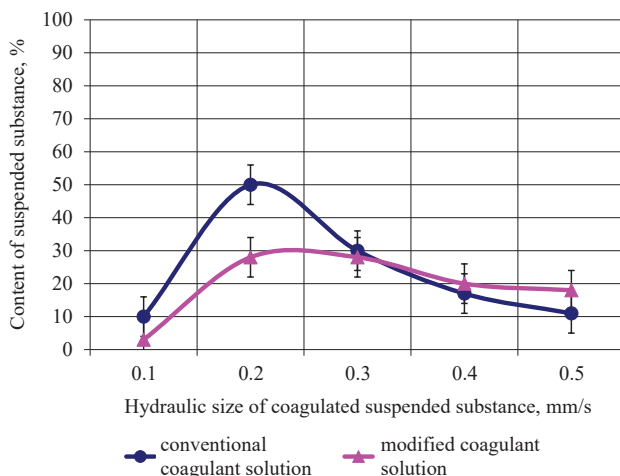

Fig. 6. Effect of the modified solution  $Al_2(SO_4)_3$  on the hydraulic size of the coagulated suspended substance in the summer period

In the winter period, treating natural water with the modified solution of aluminum sulfate decreases the content of suspension with a hydraulic size of 0.1 mm/s and less, from 85 % to 22 %. The content of suspended substances decreases at settling from 8.5–12.5 mg/dm<sup>3</sup> to 5.6–8.3 mg/dm<sup>3</sup>. In the period of spring flood, using the modified aluminum sulfate

solution decreased the content of suspension of 0.1 mm/s and less, from 55 % to 15 %. In summer, the content of suspension with a size of 0.3–0.5 mm/s increases, from 58 % (a conventional reagent solution) to 66 % (the modified reagent solution). This indicates that the use of the modified aluminum sulfate solution could intensify the process of coagulation and natural water clarification.

**5.2. Effect of the content of the starting suspended substance on water clarification when using a modified coagulant solution**

According to the recommendations given in [19], the surface source water used to supply water can be divided into the following groups:

- 1) highly turbid waters (mountain rivers and rivers in the periods of floods and rains): the amount of suspended substances is 500–1,000 mg/dm<sup>3</sup>;
- 2) turbid colored waters: the amount of suspended substances is 100–500 mg/dm<sup>3</sup>; coloration, 20–60 degrees; the amount of suspended substances is up to 100 mg/dm<sup>3</sup>; coloration, 30–100 degrees;
- 3) low turbid colored waters: the amount of suspended substances is up to 10 mg/dm<sup>3</sup>; coloration, exceeds 50 degrees.

The surface sources of water supply in Eastern Europe mainly belong to the second and third groups, that is, those are the low turbid colored waters (for example, the river Dnipro water) and turbid colored waters (for example water from the channel Seversky Donets – Donbas in separate time of year, a series of sources of water supply in the western regions of Ukraine, etc.). Therefore, in order to determine the feasibility of using a modified solution of aluminum sulfate coagulant in water purification processes, our study investigated the following:

1. The efficiency of clarification of low turbid colored waters using the modified solution of aluminum sulfate coagulant depending on the coloration and temperature of the starting water.

2. The dependence of changes in the coloration and residual content of suspended substances in clarified water on the content of suspended substances in the starting water.

The study involved the model water and water from the river Seversky Donets with the following indicators in terms of the suspended substances and coloration:

- 1) low turbid colored waters:
  - the amount of suspended substances is 5–10 mg/dm<sup>3</sup>;
  - coloration – 20–100 degrees;
- 2) turbid colored waters:
  - the amount of suspended substances is up to 500 mg/dm<sup>3</sup>;
  - coloration – 20–100 degrees.

The results of our study involving the low turbid colored waters at a temperature of the starting water of 1.4–1.9 °C and 12.1–12.6 °C are given in Table 3.

The experimental data indicate a high enough efficiency of the clarification of low turbid colored waters using the modified solution of aluminum sulfate coagulant. The effect of the modified coagulant solution is significantly larger at the water coloration over 40 degrees, which is of certain importance in the purification of highly turbid waters. The experimental findings show that the coloration of the clarified water is almost independent of the starting water temperature.

The effectiveness of the discoloration of turbid colored waters when treating water with the modified solutions of aluminum sulfate coagulants depending on the content of suspended substances in the clarified water and at a coloration of 100 degrees is shown in Fig. 7.

Table 3

Effect of the modified solution of aluminum sulfate coagulant on the discoloration of low turbid colored waters

Experiment No.	Coloration of water to be clarified, degrees	Water temperature, °C	Coloration of clarified water, degrees		Change in the clarified water coloration, %	
			Modified coagulant solution	Conventional coagulant solution	Modified coagulant solution	Conventional coagulant solution
1	20	1.4–1.9	15	17	33.3	17.6
	40		26	32	53.8	25.0
	60		37	43	62.2	39.5
	80		49	59	63.3	35.6
	100		62	76	61.3	31.6
2	20	12.1–12.6	15	16	33.3	25.0
	40		26	33	53.8	21.2
	60		37	44	62.2	36.4
	80		49	55	63.3	45.5
	100		61	72	63.9	38.9

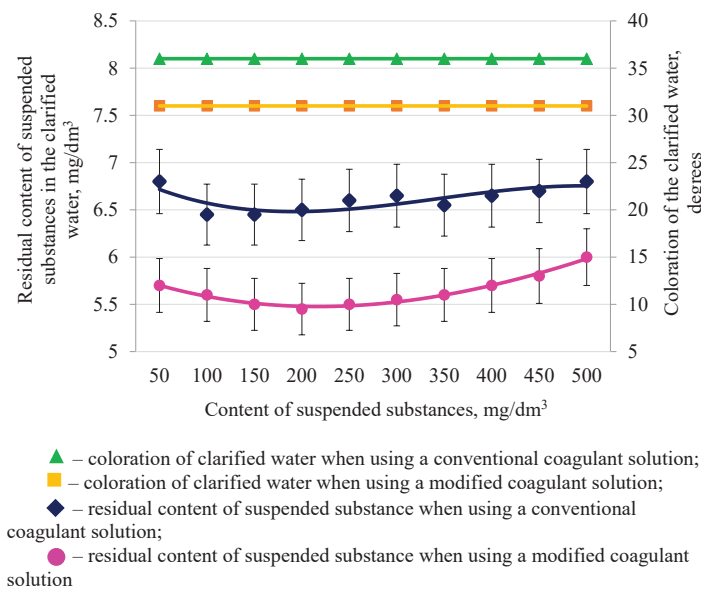

Fig. 7. Change in the coloration and residual content of suspended substances in clarified water when treating it with the coagulant solutions depending on the content of suspended substances ( $t = 17.6–17.9\text{ }^{\circ}\text{C}$ , coloration – 60 degrees)

When applying a modified reagent solution, the maximum values of the effectiveness of clarification of 97.3–98.1 % were obtained at the initial concentrations of suspended sub-

stance of 200–350 mg/dm<sup>3</sup>. When using a regular solution of aluminum sulfate at the same concentrations of suspended substance, the effectiveness of clarification amounted to 96.8–97.8 %. Afterward, there is a tendency to decrease the efficiency although the value of the coloration of clarified water is low enough. The coloration of the clarified water when treating it with a modified solution of aluminum sulfate coagulant is approximately at the same level. It was found that the purified water coloration does not depend on the content of suspended substances in the starting water, which is consistent with the research findings reported in [20, 21].

### 5. 3. Reduction of the estimation dosage of a reagent when using a modified solution of aluminum sulfate coagulant

Detecting the intensified drinking water purification processes when using a modified solution of the reagent has allowed us to assume the possibility of reducing the estimated reagent dosage while increasing a load on a sediment pond without compromising the quality of clarification. The estimated dosage of a regular solution of aluminum sulfate was 38–40 mg/dm<sup>3</sup>.

The effect of lowering the dosage of a coagulant on water transparency is shown in Fig. 8.

Reducing the coagulant dosage at regular coagulation is inappropriate as it reduces the transparency of clarified water.

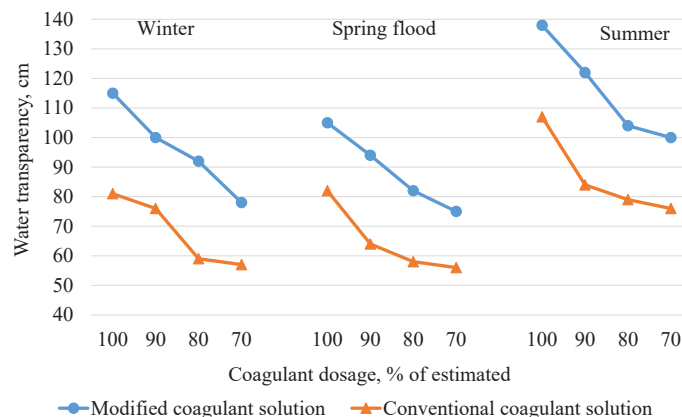

Fig. 8. Effect of coagulant dosage reduction on the transparency of clarified water

The dosage of a conventional aluminum sulfate solution ranged between 38–40 mg/dm<sup>3</sup>. In this case, the estimated dosage of the modified reagent solution was 28–30 mg/dm<sup>3</sup> while achieving the same purification parameters. However, the use of the modified aluminum sulfate solution is advisable for water whose starting concentration is 150–300 mg/dm<sup>3</sup> with a coloration of up to 20–100 degrees platinum-cobalt scale.

When using a modified coagulant solution, the dosage can be reduced by an average of 25–30 % without compromising the quality of water clarified.

**5. 4. Effect of the modified solution of aluminum sulfate coagulant on a change in the water bacterial indicators**

The study of the impact of the modified solution of aluminum sulfate coagulant on a change in the bacterial indexes of water was performed during different periods of 2018, namely: winter period – January, February; spring period – April, May. The qualitative characteristics of starting water are given in Table 4.

Table 4

The qualitative characteristics of clarified water

Parameter	Study period	
	winter	spring
Temperature, °C	2.7–3.5	10.2–10.7
General microbial number, CFU per 1 cm <sup>3</sup>	265	440
Coli-index per 1 dm <sup>3</sup>	145	160

The selection and preparation of samples for sanitary-bacteriological analysis were carried out by a membrane filtration method; determining the general microbial number – according to [22, 23].

The results of our study are given in Table 5.

Data in Table 5 show that applying a modified solution of aluminum sulfate coagulant makes it possible to improve the bacteriological indexes in the clarified water. Using an aluminum sulfate solution modified by the magnetic field and electrocoagulation has established that the quality of water purification, in terms of the bacteriological characteristics, improves compared to water treatment involving a conventional coagulant solution.

The following improvement of drinking water quality has been detected in terms of the bacteriological indicators: the efficiency of a decrease in the microbial number grows from 11.6–18.7 % to 18.6–25.1 %. The coli-index-based efficiency of purification grows from 16.6–23.1 % to 23.0–29.5 %.

It should be emphasized that the increase in bacteriological contamination in the spring period does not decrease the effectiveness of clarification when using a modified coagulant solution. The rise in temperature in the spring period makes it possible to intensify the process of coagulation of impurities, which promotes the improved efficiency of bacteriological pollution removal in particular.

**6. Discussion of results of studying the application of a modified solution of aluminum sulfate coagulant in the preparation of drinking water**

The mechanism of the influence of the modified solutions of reagents on water purification processes can be explained by the following factors: exposing aqueous solutions to an external magnetic field changes their structure and creates conditions for the formation of ion associates. These ionic associates, which were generated under the influence of a magnetic field, are the embryos of a new phase of the sub-microscopic and colloidal stages of dispersiveness. After they are stabilized by anode-dissolved iron, they act as additional centers of coagulation.

It is established that using the modified coagulant solution for water purification promotes the formation of denser shielded films that slow the diffusion of counter water flows and compounds, formed during coagulation, through the shielding hydrate films. These factors make it possible to intensify the process of impurities coagulation, increasing the efficiency of clarification and discoloration of natural water.

By studying data in Fig. 4–6, one can point to the following: the application of the modified solution of aluminum sulfate coagulant makes it possible to increase the efficiency of removal of the smallest suspended substance. Thus, in winter, the content of suspended substances with a hydraulic size of 0.1 mm/s in the clarified water decreases from 87 % to 22 %.

Table 5

Effect of the modified solution of aluminum sulfate coagulant on the improvement of water bacteriological indexes

Study period		January 2018	February 2018	April 2018	May 2018
Bacteriological indicators of water to be clarified					
General microbial number, CFU per 1 cm <sup>3</sup>		394	365	581	629
Coli-index per 1 dm <sup>3</sup>		165	171	591	611
Bacteriological indicators of clarified water					
General microbial number, CFU per 1 cm <sup>3</sup>	conventional coagulant solution	353	322	496	530
	modified coagulant solution	332	304	442	451
Coli-index per 1 dm <sup>3</sup>	conventional coagulant solution	142	144	491	495
	modified coagulant solution	137	134	133	132
Improved indicators of clarified water, %					
General microbial number, CFU per 1 cm <sup>3</sup>	conventional coagulant solution	11.6	13.4	17.1	18.7
	modified coagulant solution	18.6	20.1	21.3	25.1
Coli-index per 1 dm <sup>3</sup>	conventional coagulant solution	16.6	18.7	20.0	23.1
	modified coagulant solution	23.0	27.6	28.5	29.5



In the period of spring flood, the coagulation process improves due to the rise of water temperature in a source (Fig. 5). The content of small suspended substance decreases (to 55 %), the amount of suspended substances with a hydraulic size of 0.2 mm/s decreases, by 27 %; 0.3 mm/s and larger – by 18 %.

The content of small suspended substance (less than 0.1 mm/s) is 15 %, and, at regular coagulation, is 55 %, the content of suspended substance with a hydraulic size of 0.2 mm/s is approximately the same – 31 % and 27 %. However, the amount of the suspended substance with a hydraulic size of 0.3 mm/s and larger increases by about 2 times, 33 % and 15 %, respectively.

The suspended substances with a hydraulic size of 0.4 mm/s and larger, when using a modified coagulant, account for 21 % of the total content, and, at coagulation with the regular reagent – only 3 %.

During our study in summer (Fig. 6) it was found that the amount of small suspended substance with a hydraulic size of 0.1 mm/s and less is 1.5–2 times lower than that in the winter period and flood when using the modified coagulant solution. Using the modified coagulant solution increases the percentage of suspended substance detention, whose hydraulic size is 0.3–0.5 mm/s. Thus, when using a regular coagulant solution, the suspended substance of 0.3–0.5 mm/s accounts for 58 %, and when using the modified solution of aluminum sulfate coagulant – 66 %.

An analysis of Fig. 4–6 has revealed that when reducing the content of the starting suspended substance to 25–50 mg/dm<sup>3</sup>, the effectiveness of coagulant solution application decreases: at a concentration of suspended substance of 25 mg/dm<sup>3</sup>, the substances with a hydraulic size of 0.2 mm/s are removed by 23.1 % and 12.5 %; at a concentration of suspended substance of 50 mg/dm<sup>3</sup>, respectively, 26.2 % and 12.5 %; 100 mg/dm<sup>3</sup> – 41.6 % and 24.1 %.

Thus, the effectiveness of the impact of the modified coagulant solution on hydraulic size increases with a decrease in the latter, as evidenced by data in Fig. 4–6. The amount of suspended substances that deposited, of any hydraulic size, in the period of spring flood is higher compared to the winter period. This refers to the deposition of suspended substance in water treated with a modified solution and a conventional coagulant.

The effect of the modified solution of aluminum sulfate coagulant on a change in the coloration of starting natural water is shown in Table 3, which demonstrates that the effectiveness of lowering the coloration is higher when using a modified coagulant solution. Thus, when applying a conventional coagulant solution, the maximum efficiency value was 45.5 %; when using a modified solution – 63.9 %. However, it should be emphasized that the temperature of the starting water did not have a significant impact on the effectiveness of lowering the water coloration. Thus, when using the modified coagulant solution, both in winter, at low temperature ( $t=1.4-1.9\text{ }^{\circ}\text{C}$ ), and in the spring period ( $t=12.1-12.6\text{ }^{\circ}\text{C}$ ) the coloration decreased in about the same range of 61.3–63.9 % and amounted to about 31.5 degrees platinum-cobalt scale.

Fig. 7 shows that the content of suspended substances in clarified water when using the modified solution of aluminum sulfate coagulant is affected by the concentration of suspended substance in the starting water. Thus, at a starting concentration of suspended substance of 200–350 mg/dm<sup>3</sup>, the efficiency of using the modified coagulant solution reaches

a maximum value of 97.3–98.1 %. However, it should be noted that the coloration of clarified water is not in any way affected by the concentration of suspended substance in the starting water. Nevertheless, the modification of a coagulant solution increases the efficiency of lowering the coloration of water. Thus, when using a conventional solution of aluminum sulfate coagulant, the effectiveness of reducing the coloration of water is about 64 %, and, when using a modified coagulant solution, 69 %.

When studying data in Fig. 8, one can note that when applying a modified coagulant solution, it is possible to achieve a reduction in the estimated dosage of the reagent. It is established that the dosage of a regular solution of aluminum sulfate of 38–40 mg/dm<sup>3</sup> improves the quality of clarified water, in terms of the suspended substances and coloration, by 35–40 %. In this case, the estimated dosage of the modified reagent solution was 28–30 mg/dm<sup>3</sup> while achieving the same purification parameters. However, the use of the modified aluminum sulfate solution is advisable for water with a starting suspended substance concentration of 50–300 mg/dm<sup>3</sup> and a coloration of 20–100 degrees platinum-cobalt scale.

When applying a conventional solution of aluminum sulfate coagulant, the reduction in its estimated dosage by 30 % led to the worsening of the process of clarification during our study periods. Using the modified solution of aluminum sulfate coagulant can reduce the estimated dosage by 20–30 % without compromising drinking water quality. The better process of clarification in the summer period is due to improving the coagulation process by increasing the temperature of source water.

An analysis of data in Table 5 reveals that the quality of water purification, in terms of the bacteriological characteristics, when using a modified coagulant solution, is much higher than when treating water using a conventional coagulant solution. Thus, the reduction in the microbial number, when using a conventional coagulant solution, is 11.6–18.7 % on average; and when using the modified coagulant solution – 18.6–25.1 %.

A similar phenomenon is observed when analyzing values for the coli-index: a regular coagulant solution – 16.6–23.1 %; the modified coagulant solution is 23.0–29.5 %.

During the study, only one type of coagulant was selected – aluminum sulfate. Therefore, in the future, it is necessary to study the effect of modifying other types of coagulants and flocculants, which are used in the preparation of drinking water. It is also necessary to compare the effectiveness of the magnetic field influence on coagulants and flocculants, to test the effectiveness of the modified reagent solutions at actual water treatment plants.

The subject of further study should be the comparison of the efficiency of methods for intensifying the operation of treatment facilities, namely: a modified coagulant solution and, for example, a mixture of the coagulant and flocculant. Attention should also be given to the methods of intermittent and portioned coagulation, to investigate their effectiveness compared to the modified reagent solutions.

---

## 7. Conclusions

---

1. Our experimental study into the influence of the modified solution of aluminum sulfate coagulant on the hydraulic size of coagulated suspended substance has confirmed the

expediency of its application. Using the modified solution of aluminum sulfate coagulant makes it possible to remove the smallest suspended substance from water (0.1 mm/s and less) without changing the technological parameters of drinking water clarification. The study data, collected during different periods of the year (winter, spring, summer), have shown the greater efficacy of coagulation when using the modified solution of aluminum sulfate coagulant compared to applying a conventional coagulant solution.

2. It has been determined that the efficiency of water clarification when using a modified coagulant solution influences the content of suspended substances in the starting water. It was found that the efficacy of clarification is lower at a low concentration of suspended substance of 25–50 mg/dm<sup>3</sup> and when the starting concentration of suspended substances exceeds 350 mg/dm<sup>3</sup>. The best result of our study was demonstrated at a content of the suspended substances in the starting water, to be purified, of 150–350 mg/dm<sup>3</sup>. When the content of suspended substances exceeds 350 mg/dm<sup>3</sup>, the use of a modified coagulant solution for water treatment becomes impractical.

It should be emphasized that the content of suspended substance in starting water has an effect only on the process of water clarification. The process of discoloration of drinking water during purification in a sediment pond when using the modified solution of aluminum sulfate coagulant is not significantly affected by the content of the starting suspended substance.

3. Using the modified solution of aluminum sulfate coagulant makes it possible to reduce the estimated dosage of coagulant by 20–30 % without compromising the quality of drinking water. It is established that the dosage of a regular solution of aluminum sulfate of 38–40 mg/dm<sup>3</sup> improves the quality of clarified water, in terms of the suspended substances and coloration, by 35–40 %. In this case, the estimated dosage of the modified reagent solution was 28–30 mg/dm<sup>3</sup> while achieving the same purification parameters. However, the use of the modified aluminum sulfate solution is advisable for water with a starting concentration of 50–300 mg/dm<sup>3</sup> and whose coloration is up to 20–100 degrees platinum-cobalt scale.

The mechanism of influence of the modified reagent solution on water purification processes can be explained by a change in the coagulant solution structure. Exposing aqueous solutions to an external magnetic field changes

their structure and creates conditions for the formation of ion associates of the submicroscopic and colloidal degree of dispersiveness. The ion associates that form under the action of a magnetic field are the embryos of a new phase of the submicroscopic and colloidal levels of dispersiveness; after they are stabilized by anode-dissolved iron they act as additional coagulation centers.

4. It is discovered that the application of the modified solution of aluminum sulfate coagulant makes it possible to improve bacteriological indexes in water that is purified. Thus, we have established the improvement of drinking water quality, in terms of the bacteriological characteristics: the efficiency of reducing a microbial number grows from 11.6–18.7 % to 18.6–25.1 %. In terms of the coli-index, the efficiency of purification increases from 16.6–23.1 % to 23.0–29.5 %.

It should be emphasized that the increase in the total microbial number by 1.6 times and in the coli-index by 3.46 times in spring, when using a modified coagulant solution, makes it possible to preserve the reduction of bacteriological parameters. A decrease in the microbial number was 21.3–25.1 % and 17.1–18.7 % for the modified and conventional aluminum sulfate solutions, respectively. The coli-index also decreased – 28.5–29.5 % and 20.0–23.1 % for the modified and conventional aluminum sulfate solutions, respectively.

The rise in temperature to 10.2–10.7 °C in the spring period makes it possible to intensify the process of impurities coagulation when using the modified coagulant solution. This, in turn, contributes to the increased efficiency in the removal of bacteriological pollutants by 1.39 times in terms of the general microbial number, and by 4.63 times in terms of the coli-index. When using a conventional aluminum sulfate solution, the total microbial number decreased by 1.19 times, and the coli-index – by 1.23 times.

---

#### Acknowledgments

---

The study on the application of a modified solution of aluminum sulfate coagulant in drinking water preparation processes was performed as part of the research work «Substantiation of Technical Solutions to Improve Water Treatment Processes» (Ukraine State Registration No. 0118U000650).

---

#### References

1. Draginskiy, V. L., Alekseeva, L. P. (2000). Povyshenie effektivnosti reagentnoy obrabotki vody na vodoprovodnyh stantsiyah. *Vodosnabzhenie i sanitarnaya tehnika*, 5, 45–47.
2. Dushkin, S. S., Martynov, S., Dushkin, S. S. (2019). Intensification of the contact clarifiers work during the drinking water preparation. *Journal of Water and Land Development*, 41 (1), 55–60. doi: <https://doi.org/10.2478/jwld-2019-0027>
3. Volodchenko, O. V. (2002). Analiz metodov intensivifikatsii raboty ochistnyh sooruzheniy. *Kommunal'noe hozyaystvo gorodov*, 36, 267–271. Available at: <https://cutt.ly/bsGkEt7>
4. Onyango, L. A., Quinn, C., Tng, K. H., Wood, J. G., Leslie, G. (2015). A Study of Failure Events in Drinking Water Systems as a Basis for Comparison and Evaluation of the Efficacy of Potable Reuse Schemes. *Environmental Health Insights*, 9 (3), 11–18. doi: <https://doi.org/10.4137/ehi.s31749>
5. Dushkin, S. S., Galkina, O. P. (2019). More Effective Clarification of Circulating Water at Coke Plants. *Coke and Chemistry*, 62 (10), 474–480. doi: <https://doi.org/10.3103/s1068364x19100041>
6. Moskvichev, S. S., Mileshekin, S. I., Moskvicheva, A. V., Moskvicheva, E. V. (2019). The intensification of water purification plant work. *IOP Conference Series: Materials Science and Engineering*, 698, 055038. doi: <https://doi.org/10.1088/1757-899x/698/5/055038>

7. Coward, T., Tribe, H., Harvey, A. P. (2018). Opportunities for process intensification in the UK water industry: A review. *Journal of Water Process Engineering*, 21, 116–126. doi: <https://doi.org/10.1016/j.jwpe.2017.11.010>
8. Lin, J., Ye, W., Zhong, K., Shen, J., Jullok, N., Sotto, A., Van der Bruggen, B. (2016). Enhancement of polyethersulfone (PES) membrane doped by monodisperse Stöber silica for water treatment. *Chemical Engineering and Processing - Process Intensification*, 107, 194–205. doi: <https://doi.org/10.1016/j.cep.2015.03.011>
9. Alabi, A., Chiesa, M., Garlisi, C., Palmisano, G. (2015). Advances in anti-scale magnetic water treatment. *Environmental Science: Water Research & Technology*, 1 (4), 408–425. doi: <https://doi.org/10.1039/c5ew00052a>
10. Dushkin, S. S., Blagodarnaya, G. I. (2010). Povyshenie effektivnosti raboty gorodskih sistem vodosnabzheniya. *Scientific Bulletin of Civil Engineering*, 60, 315–319.
11. Yevdoshenko, V. V., Dushkin, S. S., Hres, O. V., Kovalenko, O. M., Blahodarna, H. I. (2017). Pat. No. 118596 UA. Sposib ochystky pryrodnykh i stichnykh vod. No. a201702868; declared: 27.03.2017; published: 10.08.2017, Bul. No. 15.
12. Blahodarna, H. I., Tykhoniuk, V. O., Dushkin, S. S. (2001). Pat. No. 45258 UA. Sposib modifikatsiyi filtruiuchoho zavantazhennia dlia osviltrennia pryrodnykh i stichnykh vod. No. 2001074832; declared: 10.07.2001; published: 15.03.2002, Bul. No. 3.
13. Dushkin, S. S. (2012). Ochistka malomutnykh vod vysokoy tsvetnosti. *Scientific Bulletin of Civil Engineering*, 71, 410–416.
14. Sadet, A., Stavarache, C., Teleanu, F., Vasos, P. R. (2019). Water hydrogen uptake in biomolecules detected via nuclear magnetic phosphorescence. *Scientific Reports*, 9 (1). doi: <https://doi.org/10.1038/s41598-019-53558-8>
15. Klassen, V. I. (1978). Omagnichivanie vodnykh sistem. Moscow: Himiya, 240. Available at: <https://www.twirpx.com/file/176541/>
16. Ternovtsev, V. E. (1976). Magnitnye ustanovki v sistemah oborotnogo vodosnabzheniya. Kyiv: Budivelnik, 88.
17. Tebenihin, E. F., Gusev, B. T. (1970). Obrabotka vody magnitnym polem v teploenergetike. Moscow: Energiya, 144.
18. Shevchenko, T. O., Epoian, S. M., Airapetian, T. S., Dushkin, S. S. (2012). Pat. No. 103698 UA. Prystriy dlia aktyvatsiyi rozchyniv reahentiv. No. a201203185; declared: 19.03.2012; published: 11.11.2013, Bul. No. 21.
19. Posobie po proektirovaniyu sooruzheniy dlya ochistki i podgotovki vody (k SNiP 2.04.02-84). Utverzhdeno prikazom NII KVOV AKH im. K. D. Pamfilova ot 9 aprelya 1985 g. No. 24. Available at: <http://www.docload.ru/Basesdoc/2/2689/index.htm>
20. Dushkin, S. S. (2003). Resursoberegayushchie tehnologii ochistki prirodnnykh i stochnykh vod. *Kommunal'noe hozyaystvo gorodov*, 51, 96–101.
21. Blagodarnaya, G. I. (2002). Modifikatsiya zagruzki fil'tra aktivirovannym rastvorom flokulyanta. *Kommunal'noe hozyaystvo gorodov*, 43, 173–177.
22. Korinko, I. V., Kobylanskyi, V. Ya., Panasenko, Yu. O. (2013). Kontrol yakosti vody. Kharkiv: KhNAHKH, 288.
23. Keeley, J., Jarvis, P., Judd, S. J. (2014). Coagulant Recovery from Water Treatment Residuals: A Review of Applicable Technologies. *Critical Reviews in Environmental Science and Technology*, 44 (24), 2675–2719. doi: <https://doi.org/10.1080/10643389.2013.829766>