

A mathematical and physical model of the critical pneumatic conveying modes has been developed to ensure the calculation and construction of pneumatic product pipelines of continuous operation. The model takes into consideration the technological conditions of gas suspension movement; the laws of movement of individual fine particles, accounting for their impact interaction and decompression, as well as the actual boundary conditions for a food product movement. The parameters of the zone of dynamic destruction of the layer of a small-piece food product by impact air-wave were experimentally studied; the results of the calculation have been compared with the experimental data.

The process of managing critical pneumatic conveying modes has been theoretically described, based on the proportional elements and feedback (a current loop of 4–20 mA); the process of destruction of the cluster of products by airwave and controlled decompression has been studied. The process of pneumatic conveying of a small-piece product at the experimental bench system has been examined. As well as the process of moving the material in the product pipeline, which is controlled by compressed air pulses, to maintain the modes of operation.

The following has been established: pressure losses caused by the movement of clean air; additional pressure losses resulting from the movement of the material; the loss of pressure required for transporting in a suspended state on a vertical stretch.

A model has been developed to calculate the coordinates of a product particle when it collides with the inner surface of the product pipeline, as well as a change in its kinematic characteristics. The developed model makes it possible to determine the rational modes of pneumatic conveying and possible energy costs in the processing of various small-piece materials. The rational pneumatic conveying regimes have been determined, as well as possible energy costs in the processing of small-piece materials. As the time of supplying compressed air in the product pipeline increases, the number of product particles reaches a maximum in the range of 0.1...0.2 s. The compressed air flow rate, depending on the value of inlet mainline pressure P (0.1...0.3 MPa), is 80...160 (Nl/min). A general approach to the modeling of pneumatic conveying systems has been proposed

Keywords: pneumatic conveying, small-piece, excess pressure, feedback, gas suspension

UDC 621.316

DOI: 10.15587/1729-4061.2020.213176

PRACTICAL ASPECTS IN MODELING THE AIR CONVEYING MODES OF SMALL–PIECE FOOD PRODUCTS

L. Kryvoplias-Volodina

Doctor of Technical Sciences, Professor
LTD CAMOZZI
Kyrylivska str., 1-3, Kyiv, Ukraine, 04080
E-mail: kryvopliasvolodina@camozzi.ua

O. Gavva

Doctor of Technical Sciences, Professor*
E-mail: gavvaoleksandr@gmail.com

M. Yakymchuk

Doctor of Technical Sciences, Professor
SE FESTO

Borysohlibska str, Kyiv, Ukraine, 04070

E-mail: mykolaiaikymchuk.2016@gmail.com

A. Derenivska

PhD*

E-mail: anastasya.d@gmail.com

T. Hnativ

Postgraduate Student*

E-mail: taras.gnativ@gmail.com

H. Valiulin

PhD, Associate Professor*

E-mail: vg972721@gmail.com

*Department of Mechatronics
and Packaging Technology

Educational-Scientific Engineering-Technical Institute
named after acad. I. S. Gulyiy

National University of Food Technologies

Volodymyrska str., 68, Kyiv, Ukraine, 01601

Received date 02.09.2020

Accepted date 25.09.2020

Published date 22.10.2020

Copyright © 2020, L. Kryvoplias-Volodina, O. Gavva, M. Yakymchuk, A. Derenivska, T. Hnativ, H. Valiulin

This is an open access article under the CC BY license

(<http://creativecommons.org/licenses/by/4.0>)

1. Introduction

The use of pneumatic conveying for delivering small-piece food products to the area of technological processing has a series of advantages: environmental friendliness, cleanliness, changing modes of operation during the continuous transportation process, the introduction of proportional monitoring systems in management. Promising mathemat-

ical models of pneumatic conveying of food products are formed on the basis of incremental material parameters of a pneumatic pipeline [1–3].

Additional technical challenges arise when calculating a modern pneumatic conveying pipeline for small-piece food products. It is necessary to introduce elements of monitoring drives, as well as the theory of their calculation to the generalized mathematical model of a pneumatic pipeline [2–5].

It is a relevant task to build scientifically-substantiated models for the calculation of pneumatic conveying installations considering the use of turbulent airflows, insufficiently studied, especially near the walls of a pipeline [2, 4, 6, 7].

Over the past half-century, this process has been addressed by many authors who have accepted various assumptions in order to simplify its mathematical notation [8]. For a long time, this approach was justified, but in recent years, due to the introduction of proportional equipment, as well as integrated management systems, the performance of pneumatic product pipelines has increased significantly [9–11]. Given this, many mathematical models [12–15] of their operating regimes and control systems have become unacceptable for practical use.

The current controlling and mathematical models describing the dynamics of the pneumatic conveying process of food products are simplified; most often their description does not correspond to the real phenomena arising in technological equipment. Therefore, to consider the operation of a pneumatic line in a dynamic mode, it is necessary to investigate and develop mathematical models based on physical modeling. Accordingly, promising issues today are the development and application of technically advanced designs of pneumatic product pipelines for different types of storing facilities, technological areas for dosing bulk, small-piece food products. The challenge is to build flexible pneumatic conveying automation systems to improve productivity by three to five times and reduce actual costs by 30 to 50 %. Issues are also tackled to develop and implement the principles of transporting bulk, small-piece materials through pipelines with compressed air in a dense layer without congestion.

Therefore, modeling the process of pneumatic conveying of small-piece food products, taking into consideration the real boundary conditions, as well as the migration of particles across the flow due to hydrodynamic forces, electrical forces can be considered important to describe the dynamics of the process of pneumatic conveying of food products, maximally corresponding to the actual phenomena arising in technological equipment.

2. Literature review and problem statement

Each group of products has certain properties. Therefore, during their transportation through a pneumatic product pipeline, appropriate parameters are needed. Namely, the geometry of working pipelines and the processing regime, which largely depends on the pressure management system.

This explains the presence of a large variety of pneumatic conveying equipment in the market. At the same time, there are cases when even the most advanced pneumatic product pipelines, when replacing the manufacturer for the same group of small-piece products, cease to provide the necessary productivity of transportation. Therefore, the modeling of pneumatic conveying installation processes has been given considerable attention over many decades [5].

The use of empirical procedures [7, 9, 16] cannot provide a complete calculation of the installations, including changes in the characteristics of a two-component flow under different installation's modes of operation [17–19]. Using the most general theoretical description of the pneumatic conveying process mentioned in papers [1, 8], objective difficulties associated with a complicated system of equations [4, 5] in

a differential form. Which makes the appropriate attempts at a direct solution quite difficult. The issues related to the analytical description of the processes of particle interaction during transportation between each other and with the channel walls remained unresolved. All this suggests that physical modeling [20] helps solve complex problems of this kind.

Thus, work [4], which considers the process of grain processing in a pneumatic conveying system, reports the extended results of the research. In addition to quantifying the transportation process, the authors described pressure drop modes between the inlet and outlet of a product pipeline, as well as the effect of abrasive pipeline wear and the flow elements of the model.

Additionally considered is the technology of pneumatic conveying based on the use of standard equipment with a source of compressed air – a serial press compressor [5]. In this case, the open and closed model does not take into consideration the presence of a critical speed on the vertical sections of a working channel. Papers [6, 7] also examined the universal dependence by Zenz in the logarithmic scale for the case of transporting a mixture. Experiments conducted for materials such as wheat, bran, granular yeast, confirmed the general regularity of the pneumatic conveying regime. The reason for this may be the conditions associated with the necessary speed of air movement, which was 1.5...1.8 times higher than the estimated speed [8]. This is essential for calculating the performance, total compressed air energy consumption, and product supply stability, but this approach can lead to significant errors.

Work [9] proposes a mathematical model of the two-phase flow of loose medium in the supercharged pneumatic pipeline. The constrictions, extensions, turns of the pneumatic pipeline are taken into account through different types of hydraulic resistance ratios. Experiments and numerical calculations on the proposed mathematical model showed a typical distribution of the speeds of particle mass and pressure transport along the route. However, the particle was accepted as a material point, without taking into consideration changes in the environment.

Paper [10] examines the formation of vaults (congestion) of loose products in the curved areas of a pneumatic pipeline using the Euler-Lagrange approach. However, the process is considered without taking into consideration the change in pressure during continuous transportation at the material's congestion areas. Similar shortcomings are inherent in work [11]. This makes the relevant research impractical for certain food groups.

Study [12] reports both the mathematical and experimental research into the process of transporting small-piece products during pneumatic conveying. However, the issues that take into consideration the geometry of the pneumatic pipeline remained unresolved. The authors show that there is a fairly large discrepancy between the theoretical and experimental data; the accuracy and limitations of the DPM solid-state modeling method, used in the cited study, are discussed. There is a certain gap between the results of the simulation and the actual experiment because the shape of the particle is not taken into consideration, and the forces of the particles are based on existing theories that come from the material point. Paper [13] proposes a new approach to the mathematical modeling of the process involving the elements of a pneumatic pipeline, but it does not take into consideration the

features of the control system with controlled feedback. Study [14] disregards energy components during the collision of a particle with the wall and particles with particles that are more intense in the pumping pipeline. The study mostly considered the linear trajectories of particles, which does not give a full description of the real process of pneumatic conveying.

Work [14] proposes a mechanism for modeling actual collisions between particles, but the particle movement is treated only by a Lagrange model with three sets of grids to reduce computational time, which makes it more restrictive for the study of actual processes. Paper [15] reports the results of a study on the experimental model of the influence of channel width and particle sizes on the formation of clusters. It is shown that the concentration of particles near the wall decreases with the reduction of channel width and the increase in particle size but there is no mathematical modeling of the process.

In addition, the pneumatic conveying process is addressed in works [16, 17]. The authors described and determined the resistance ratios that significantly affect the movement of two-phase environments in different parts of the pipeline. However, there is no mathematical model for calculating the loss of pressure for the acceleration of transported particles when they are involved in the transport pipeline.

An explanation of the phenomena occurring during the movement of air mixtures in a pneumatic pipeline can be a variant to overcome the corresponding difficulties [18, 19]. It is this approach that has led to the outline and implementation of a series of new technical solutions to improve the pneumatic conveying of small-piece materials based on the use of the structured modes of air mix movement.

The same approach is described in work [20] without taking into consideration the influence of the control system on the process.

The results of the experiments revealed that the mechanism of pneumatic conveying is subject to hydrodynamic laws but requires additional theoretical justifications when using products and materials that differ in properties.

Based on the analysis of scientific research, it has been established that there is no single point of view on the creation of a universal estimation model of pneumatic conveying flows [1–20].

With the development of computer technology, the above models were somewhat refined to study the process of pneumatic conveying considering the previously uncounted factors. At the same time, the coefficients were often used, which are derived with certain difficulties and which have almost no effect on the result. However, the complication of models for engineering calculations is often impractical as the real properties of processed materials cannot always be fully accounted for in theoretical models.

At the same time, the analysis of calculations, as well as experimental and practical data, has shown the shortcomings of known models [7, 9, 14, 20].

These shortcomings can be explained by the use of classical solutions. Such solutions were obtained without taking into consideration the influence factors of the rotation of individual particulate matter in pneumatic conveying equipment, as well as without analysis of the control system with the elements of feedback.

Thus, it is true that a study into a new approach to the modeling of pneumatic conveying regimes, which is

based on the properties of a separate group of products, is relevant.

3. The aim and objectives of the study

The aim of this study is to mathematically and physically model the process of the pneumatic conveying of small-piece products, as well as critical modes to ensure the calculation and design of product pipelines with a continuous supply.

To accomplish the aim, the following tasks have been set:

- to investigate the process of transporting small-piece products in a working pneumatic pipeline;
- to develop a control system, as well as real boundary conditions for the geometric, kinematic, and dynamic parameters;
- to determine the rational parameters of both the management process and the process of transporting a product in general, as well as to ensure that the required distribution of compressed air pressure at the predefined performance is provided;
- to build a mathematical model of the movement of individual rotating particles to study the process of their collision against the walls of a product pipeline;
- to develop and justify control models with the critical pneumatic conveying modes based on the proportional elements and feedback (a current loop of 4–20 mA).

4. The study materials and methods

4.1. Studying the process of transporting small-piece products in a working pneumatic pipeline

Our experimental and theoretical studies are based on the application of the fundamental laws of theoretical mechanics, the hydrodynamics of multiphase environments, the theory of solving ordinary differential equations. As well as taking into consideration equations in private derivatives, numerical methods; the mechanics of the deformable body; our own findings from experimental research of pneumatic conveying processes.

An installation for vertical pneumatic conveying is schematically shown in Fig. 1 considering works [2–5]. The working vertical channel of the product pipeline passes into the feeder's auger hopper area, which directs a small-piece product into the compressed air supply area. The small-piece product accelerates at a section of length l_1 , and reaches a constant characteristic speed u , at which it moves up the pipe. In the vertical pipe, the movement of the product is represented by two areas: l_1 is the acceleration section (the concentration of product particles decreases from the bottom up); l_2 is the stabilization section of product movement where the speed and concentration in the flow are constant. According to [7], the proportion of solid particles in a flow β is the volume concentration in the range of 0.01 to 0.04 (up to 4 %).

4.2. Control system

A combination of the feedback control system (the current loop format is 4...20 mA) was chosen as a system for controlling the flow of compressed air in the vertical channel. The possibility of regulating the control signal for current on a control solenoid of 0...5 s was taken into consideration (Fig. 1).

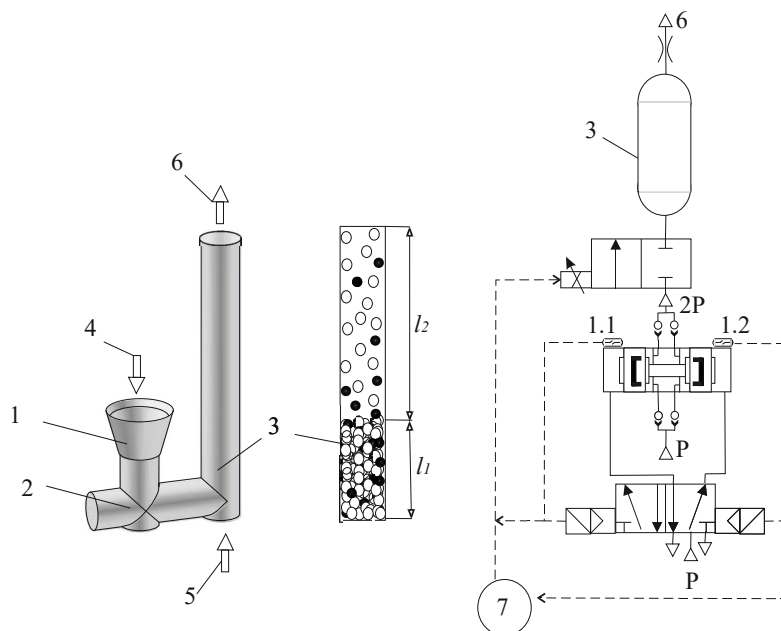

Fig. 1. Schematic transportation of small-piece products in the pneumatic conveying technological module:

- 1 – loading bunker, 2 – supply zone of a product by an auger feeder,
- 3 – vertical transporting channel; 4 – product, 5 – compressed air;
- 6 – gas suspension (air, small-piece product), 7 – electro-pneumatic control unit; P – main pressure of compressed air (MPa),
- $2P$ – double pressure at the outlet of the booster; 1.1., 1.2. – reed sensors; l_1 , l_2 – the length of the acceleration and stabilization sections (m)

The control system in Fig. 2 employs CAMOZZI elements: series 130 drivers to control the proportional valve dispensers, type AP (2/2), electronic sensor/pressure relay, SWCN series, booster 40M2L100A120MC02. The PWM signal, formed by the driver, generates, in the closed circuit of current regulation of 4.20 mA, a signal with a frequency of up to 500 Hz to the coil of the solenoid of the electromagnetic valve of compressed air supply to the system of the vertical channel of the product pipeline. The power voltage in the control circuit is 24 VDC ($\pm 10\%$) in accordance with the chosen proportional distributor AP. The flow rate of compressed air will depend on the value of the incoming mainline pressure P (0.1...0.3 MPa), and, according to data from [17, 18], are 80...160 (Nl/min). The use of pneumatic conveying automation methods is based on a model that represents the integrated ideas about particle movement in an inseparable flow in a dense phase. To combine the main characteristics for a dispersed environment (flow rate, density, mass, pressure), it is necessary to take into consideration the kinematic and dynamic characteristics that are created in the flow of the material.

4. 3. Determining the rational parameters in the control system

The kinematic and dynamic characteristics of pneumatic conveying of certain types of products have been investigated in the course of experiments on individual pneumatic conveying modes (Fig. 2).

The mechanism of the pneumatic conveying process, characteristic of most technological processes, is illustrated by a photograph of the experimental bench, when using different types of small-piece products (for a better rep-

resentation of the transportation process, a frame-by-frame formation of the stabilization area is shown in Fig. 3).

In this case, dried black pepper peas were selected for research, as well as one of the most common dry granular breakfasts with cereals [1, 8, 12].

The above photograph shows that in the vertical zone of the transporting channel, there is a division of the product into acceleration and stabilization sections. In a vertical pipe, the gas flow moves at an average fictitious speed. The speed of particulate matter relative to the flow is easy to estimate as it is close to the hover velocity [19] for vertical pneumatic conveying.

Let us consider the process of the pneumatic conveying of a small-piece product in the experimental bench system. The process of rotation of particles in the gas flow is associated with the absence of spherical form, the presence of impact interaction between the particles and wall of a product pipeline, as well as the presence of the effect of spinning the particles by individual small turbulent vortices.

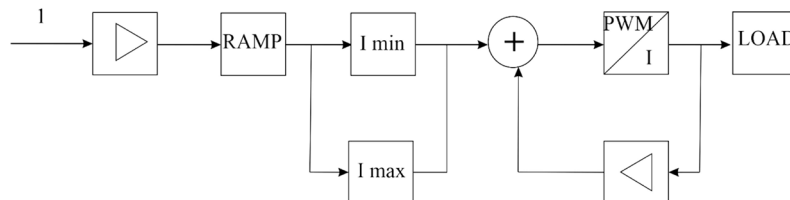

Fig. 2. Control signal transmission scheme for the pulsed supply of compressed air in a vertical pipeline: 1 – standard signal; RAMP – calibration of acceleration time; I_{min} , I_{max} – current load (mA); PWM – power management by the method of pulsating enabling/disabling the device; I – current calibration (mA) that sets the maximum value of the current fed to the valve with a support signal of 100 %; LOAD – a load in the control circuit

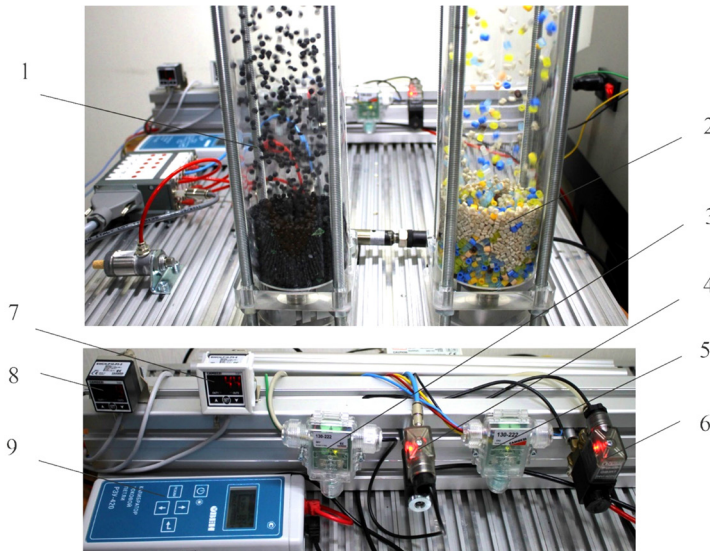

Fig. 3. Experimental bench for studying the critical pneumatic conveying regimes of small-piece food products: 1, 2 – vertical transporting channels; 3, 5 – control drivers of the proportional supply of compressed air pulse; 4, 6 – proportional electromagnetic distributors of direct action 2/2; 7, 8 – electronic vacuum/pressure relays with analog output; 9 – programming device for setting the law of signal change 4...20 mA

Consider the process of pneumatic conveying, controlled by compressed air pulses that cause working modes.

The airflow is formed at the inlet to the channel with the product, by using a pneumatic valve, which is controlled by the generation of current in line with the Heaviside function (a single step function). The measured current value in mA (at a resolution of 0.001 mA) relative to the standard scale $I_{max}, I_{min}=4...20$ mA, was registered in the ranges of 4.1 mA...19.9 mA; 12 mA...19.9 mA. The flow rate characteristic of the pneumatic valve in the installation is 180 Nl/min. The function period duration was accepted by up to 0.3 s.

4. 4. Building a mathematical model

By stating the problem of mathematical modeling, consider the movement of the spherical particle of radius r' , density ρ' in the turbulent gas flow. Provided: the flow is stationary, the gas is incompressible, the kinematic viscosity $\nu=\mu/\rho$. μ is the dynamic viscosity of the gas (compressed air), ρ is the air density. Since the flow of compressed air is turbulent, the resistance to the movement of the particle relative to the gas is subject to a non-linear law. Therefore, the particle is affected by the gravity $G=\rho' \cdot g'$, (H); g' – is the vector of the acceleration of gravity. The input parameters of the mathematical model: the radius of the particle is $r'=3 \cdot 10^{-3}$ (m); the density of a single particle of a small-piece product is $\rho'=1.24 \cdot 10^{-3}$ (kg·m⁻³); the air density is $\rho=1.24 \cdot 10^{-3}$ (kg·m⁻³); the acceleration of free fall is $g=9.81$ (m·s⁻²); the maximum compressed air flow rate is $v_m=20$ (m·s⁻¹); the dynamic viscosity is $\mu=1.82 \cdot 10^{-5}$ kg/(m·s); the pipe radius is $b=0.05$ m. In the compressed air flow, the particle is set into a rotational motion, which predetermines the motion equations (Fig. 4):

$$\frac{\pi}{6} (2 \cdot r')^3 \rho' \frac{du_i}{dt} = D'(v_i - u_i) + G_i + F_i, \tag{1}$$

$i=x, y, z$; v_i is the projection of the vector of the velocity \vec{v} of compressed air, u_i is the projection of the particle velocity vector \vec{u} relative to the stationary count system x, y, z . F_i is the projection of the Rubinov-Keller force vector onto the spherical surface of a particle on the side of compressed air when rotated. G_i is the projection of the gravity vector onto a particle, where

$$D' = 6\pi\mu r' \left(1 + 0.065 \left(\frac{2}{\mu} r' \rho' \sqrt{u - \bar{v}} \right) \right)^{\frac{3}{2}}. \tag{2}$$

Represent the equation of the rotational motion of particles together with motion equation (1)

$$\begin{cases} \frac{4}{3} \pi \cdot r'^3 \cdot \rho' \cdot \frac{du_x}{dt} = D'(v_x - u_x) + G_x + F_x, \\ \frac{4}{3} \pi \cdot r'^3 \cdot \rho' \cdot \frac{du_y}{dt} = D'(v_y - u_y) + G_y + F_y, \\ J \cdot \frac{d\omega}{dt} = -\pi\mu (2 \cdot r')^3 \cdot \left(\frac{1}{2} \cdot \frac{\partial v_x}{\partial y} - \omega \right). \end{cases} \tag{3}$$

where $\omega=\omega z$ is the projection onto the vector's z axis of the angular velocity when the particle rotates; J is the moment of particle inertia relative to the central axis, which is parallel to the Oz axis:

$$J = \left\{ \pi \cdot (2 \cdot r')^5 \rho' \right\} / 60.$$

Record quantities u_x, u_y in the following form:

$$u_x = \frac{dx}{dt}; \quad u_y = \frac{dy}{dt}. \tag{4}$$

The projections of forces on the axes of coordinates are represented as equations (5), (6):

$$G_y = -\frac{1}{6} \pi \cdot (2 \cdot r')^3 \rho' g, \quad G_x = 0, \tag{5}$$

$$F_x = \frac{\pi}{8} (2 \cdot r')^3 \rho' \omega (v_y - u_y),$$

$$F_y = -\frac{\pi}{8} (2 \cdot r')^3 \rho' \omega (v_x - u_x). \tag{6}$$

As a result of fitting (4) to (6) to system (3), we obtain a system of three differential equations relative to three unknowns $x(t), y(t), z(t)$:

$$\begin{aligned} & \frac{4}{3} \pi \cdot r'^3 \rho' \frac{d^2x}{dt^2} = 6 \cdot \pi\mu r' \times \\ & \times \left(1 + 0.065 \cdot \left(\frac{2}{\mu} r' \rho' \cdot \sqrt{\left(\frac{dx}{dt} - v_x \right)^2 + \left(\frac{dy}{dt} - v_y \right)^2} \right)^{\frac{3}{2}} \right) \times \dots \\ & \dots \times \left(v_x - \frac{dx}{dt} \right) + \frac{\pi}{8} \cdot \rho' (2 \cdot r')^3 \cdot \omega \cdot \left(v_y - \frac{dy}{dt} \right), \end{aligned} \tag{7}$$

$$\frac{4}{3}\pi \cdot r^3 \rho' \frac{d^2y}{dt^2} = 6 \cdot \pi \mu r' \times$$

$$\times \left(1 + 0.065 \cdot \left(\frac{2}{\mu} r' \rho' \cdot \sqrt{\left(\frac{dx}{dt} - v_x \right)^2 + \left(\frac{dy}{dt} - v_y \right)^2} \right)^{\frac{2}{3}} \right)^{\frac{3}{2}} \times \dots$$

$$\dots \times \left(v_y - \frac{dy}{dt} \right) - \frac{1}{6} \cdot \pi \rho' \cdot g (2 \cdot r')^3 - \frac{\pi}{8} \cdot \rho' \omega (2 \cdot r')^3 \cdot \left(v_x - \frac{dx}{dt} \right), \quad (8)$$

$$J \cdot \frac{d\omega}{dt} = -\pi \mu (2 \cdot r')^3 \cdot \left(\frac{1}{2} \cdot \frac{\partial v_x}{\partial y} - \omega \right). \quad (9)$$

Let b be the radius of a product pipeline (m), v_m is the maximum speed of compressed air flow, then, for the turbulent current in the layer $y \in [0, 2b]$, that is, for $0 \leq y \leq b$:

$$v_x = v_m \left(\frac{y}{b} \right)^{\frac{1}{7}};$$

$$v_y = 0;$$

$$\frac{\partial v_x}{\partial y} = \frac{1}{7} v_m \left(\frac{1}{by^6} \right)^{\frac{1}{7}},$$

for $b \leq y \leq 2b$:

$$v_x = v_m \left(\frac{2b-y}{b} \right)^{\frac{1}{7}};$$

$$v_y = 0;$$

$$\frac{\partial v_x}{\partial y} = \frac{1}{7} v_m \frac{1}{b} \left(\frac{b}{2b-y} \right)^{\frac{6}{7}}.$$

Rewrite the system of equations (3) taking into consideration the transforms described above:

$$\frac{4}{3}\pi \cdot r^3 \rho' \frac{d^2x}{dt^2} = 6 \cdot \pi \mu r' \times$$

$$\times \left(1 + 0.065 \cdot \left(\frac{2}{\mu} r' \rho' \cdot \sqrt{\left(\frac{dx}{dt} - v_x \right)^2 + \left(\frac{dy}{dt} \right)^2} \right)^{\frac{2}{3}} \right)^{\frac{3}{2}} \times \dots$$

$$\dots \times \left(v_y - \frac{dx}{dt} \right) - \pi \rho' (r')^3 \omega (2 \cdot r')^3 \cdot \left(\frac{dy}{dt} \right), \quad (11)$$

$$\frac{4}{3}\pi \cdot r^3 \rho' \frac{d^2y}{dt^2} = -6 \cdot \pi \mu r' \times$$

$$\times \left(1 + 0.065 \cdot \left(\frac{2}{\mu} r' \rho' \cdot \sqrt{\left(\frac{dx}{dt} - v_x \right)^2 + \left(\frac{dy}{dt} \right)^2} \right)^{\frac{2}{3}} \right)^{\frac{3}{2}} \frac{dy}{dt} - \dots$$

$$\dots - \frac{4}{3} \pi \cdot \rho' (r')^3 - \pi \cdot \rho' (r')^3 \cdot \omega \cdot \left(v_x - \frac{dx}{dt} \right), \quad (12)$$

$$J \cdot \frac{d\omega}{dt} = -\pi \mu (2 \cdot r')^3 \cdot \left(\frac{1}{2} \cdot \frac{\partial v_x}{\partial y} - \omega \right). \quad (13)$$

Initial conditions for finding five arbitrary *const* of the integration:

- at the initial moment of movement $t=0$; $x(0)=x_0$;
- $y(0)=y_0$;
- to determine the projections of the velocity vector at the initial point in time:

$$\left. \frac{dx}{dt} \right|_{t=0} = u_{x_0}, \quad \left. \frac{dy}{dt} \right|_{t=0} = u_{y_0};$$

- at the initial point in time, the angular velocity of the particle's rotation:

$$\omega(0) = \omega_0;$$

- the estimation scheme of particle kinematic characteristics for the established mode of transportation (Fig. 4).

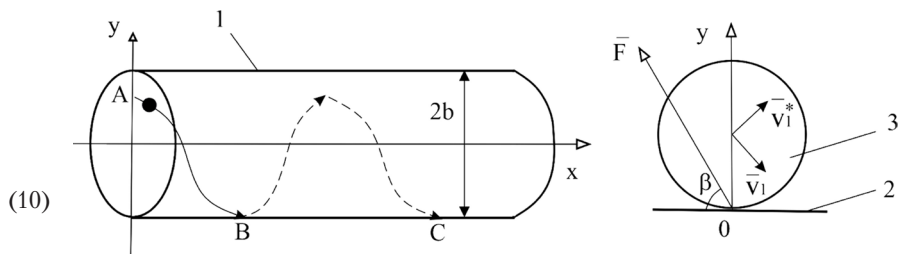

Fig. 4. Particle trajectory with common kinematic characteristics:
1 – product pipeline, 2 – inner wall of the product pipeline,
3 – particle of a small-piece product

4. 5. Substantiation of control model with the critical pneumatic conveying modes

During the collision of particles with the wall of a product pipeline, it is necessary to calculate the speed after the rebound from the surface, taking into consideration the possible trajectories. To calculate the kinematic parameters of particle behavior after the impact contact against the product pipeline wall, we shall take the radius of the spherical particle to be $r=d/2$; all parameters after the impact have the designation *.

Particle characteristic during the impact:

$$M(\dot{x}_1^* - \dot{x}_1) = -|F| \cos \beta,$$

$$M(\dot{y}_1^* - \dot{y}_1) = |F| \sin \beta,$$

$$M(x_1(\dot{y}_1^* - \dot{y}_1) - y_1(\dot{x}_1^* - \dot{x}_1)) + J_1(\omega_2^* - \omega_2) = 0. \quad (14)$$

M is a function of the position of the object. To restore the normal and tangential particle speed, we introduce coefficients $0 \leq k_n < 1$, then the coordinates of the movement of the center of the mass of a particle:

$$\dot{y}_1^* = -k_n \cdot \dot{y}_1,$$

$$\dot{x}_A^* = k_\tau \cdot \dot{x}_A. \quad (15)$$

If we determine the linear velocity of the points on the sphere, we shall use the Chasles theorem [9]. In the event of moving before the impact:

$$\bar{v}_A = v_1 + \left(\bar{\omega} \cdot \overline{CA} \right). \quad (16)$$

In the case of moving after the impact:

$$\bar{v}_A^* = v_1^* + \left(\bar{\omega}^* \cdot \overline{CA} \right). \tag{17}$$

As a result of mapping the vector space onto the x axis, we obtain:

$$\begin{aligned} \dot{x}_A &= \dot{x}_1 + \frac{d}{2} \omega_z, \\ \dot{x}_A^* &= \dot{x}_1^* + \frac{d}{2} \omega_z^*. \end{aligned} \tag{18}$$

After fitting (18) to (15) and corresponding transforms, the value of the angular ω_z^* and \dot{x}_1^* linear speeds of particle movement after the impact is obtained:

$$\begin{aligned} \omega_z^* &= \frac{J_{z1} + \frac{md^2}{4} k_\tau}{J_{z1} + \frac{md^2}{4}} \omega_z - \frac{1}{2} \left(\frac{md(1-k_\tau)}{J_{z1} + \frac{md^2}{4}} \right), \\ \dot{x}_1^* &= k_\tau \dot{x}_1 + k_\tau \frac{d}{2} \omega = \\ &= - \left\{ \frac{J_{z1} + \frac{md^2}{4} k_\tau}{J_{z1} + \frac{md^2}{4}} \cdot \frac{d \cdot \omega_z^2}{2} + \frac{1}{4} \left(\frac{md^2(1-k_\tau)}{J_{z1} + \frac{md^2}{4}} \right) \right\}. \end{aligned} \tag{19}$$

The resulting mathematical model of the pneumatic conveying mode described above is solved by reducing the equations of motion to the canonical form. Numerical methods of calculation using the Runge-Kutta theory. The subprogram is based on a scheme of the fourth order of accuracy. This provides an opportunity to obtain initial results for experiments on studying the critical modes of pneumatic conveying of small-piece products.

5. Practical aspects of the mathematical and physical modeling of the pneumatic conveying process

Fig. 5 shows the calculation results based on the developed mathematical model. The first stage shows when the installation enters a stationary pneumatic conveying mode. As the air is accumulated in the air receiver (Fig. 1), the speed and pressure increase (Fig. 5, a). The stationary mode is conditioned by the speed and pressure of the air, which during the operation of the installation remain constant, taking into consideration the mode of transportation. Air speed and input pressure are the main conditions for the start of product transportation. The second stage is related to the established mode of product transportation. The acceleration of the material is due to the time interval of 0.1...0.3 s and depends on the pre-defined control modes of compressed air supply. Fig. 5, b clearly demonstrates the distributions of the linear speed of the movement of a small-piece product when moving in the channel of the product pipeline under pressure. This confirms the simulation results reported in [7] concerning the impact of local resistances on the increase in unit pressure losses.

The purpose of physical modeling is to determine the pressure in the pneumatic conveying channel under the condition of the pulsed supply of compressed air, as well as the assessment

of energy costs. Physical simulation of the pneumatic conveying process was carried out for small-piece products with the above-described working conditions and product properties.

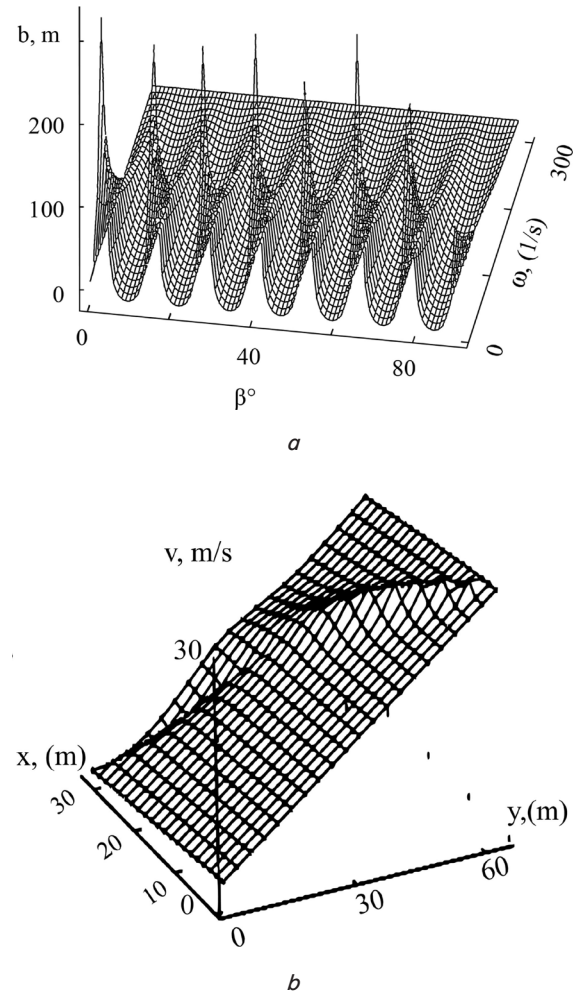

Fig. 5. Kinematic parameters of transporting a small-piece product in a product pipeline at different values of structural parameters: a – a change in the angular velocity ω of the particle movement after its contact with the wall of the product pipeline; b – a change in the linear speed of movement of a small-piece product v when moving in the channel of the product pipeline under pressure

Fig. 6 shows the results of modeling the pneumatic conveying modes of a small-piece product (dried pepper peas) in a working channel of the product pipeline with different conditions of compressed air pulse formation. The values of the actual changing pressure in the channel were obtained. This makes it possible to set the proper pressure ranges in mathematical modeling problems. The effect of compressed air pressure disturbances during the operation of the pneumatic product pipeline can form a pseudo-stationary regime. When curves 1–3 (Fig. 6) describe long time delays during the supply of compressed air into the channel, longer than 1 s. Then in the horizontal part, there can form an underlying layer, the transportation is complicated. Curves 4–7, Fig. 6, with delay intervals of up to 0.2 s make it possible to describe a stationary mode of pneumatic conveying, subject to constant pumping of the product. The maximum frequency of pulses during pneumatic conveying was up to 1.5...20 Hz, at a pressure up to 2.5 bar.

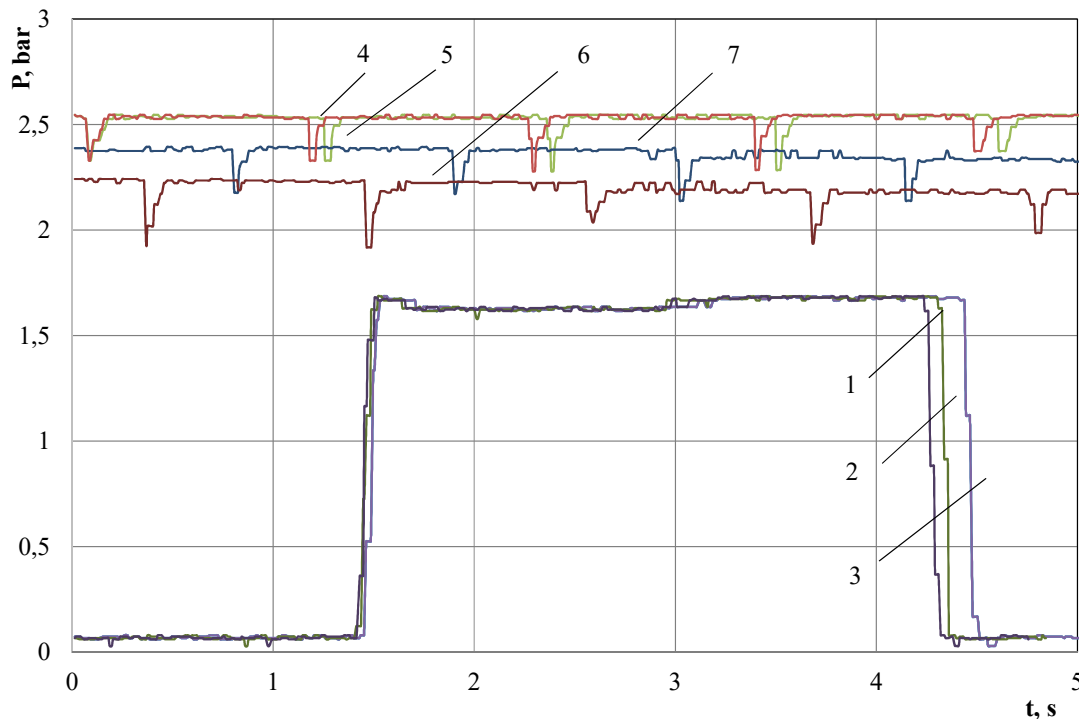

Fig. 6. Experimental data on changes in pressure in the pneumatic conveying channel of the bench under the following modes: 1 – $I_{max}..I_{min}=4.1..19.9$ mA, air supply frequency 0.3 Hz; 2 – $I_{max}..I_{min}=4.1..19.9$ mA, air supply frequency 0.35 Hz; 3 – $I_{max}..I_{min}=4.1..19.9$ mA, air supply frequency 0.37 Hz; 4 – $I_{max}..I_{min}=12.0..19.9$ mA, air supply frequency 0.6 Hz; 5 – $I_{max}..I_{min}=12.0..19.9$ mA, air supply frequency 0.75 Hz; 6 – $I_{max}..I_{min}=12.0..19.9$ mA, air supply frequency 0.5 Hz; 7 – $I_{max}..I_{min}=12.0..19.9$ mA, air supply frequency 1 Hz

The results of our simulation make it possible, through the mechanical and mathematical studies, to describe the dependences of the basic kinematic parameters of product transportation and to forecast a drop in head pressure.

The results of the pressure change at the inlet to the pneumatic product pipeline, shown in Fig. 6, are predetermined by the internal pressure fluctuations of 20 Hz per 1 pressure cycle. This mode of air supply is organized by the driver of the series 130, (Fig. 2). At the same time, these modes of transportation depend not only on the pressure [18] but also on the type of product being moved.

6. Discussion of results of the theoretical and physical modeling of the process

Our results are explained, first of all, by the fact that the shape of the working channel of pneumatic conveying and the diametric cross-section of the working channel were taken into consideration. As the time of compressed air supply in the product pipeline increases, the number of extrusion particles reaches a maximum in the range of 0.1...0.2 s (Fig. 6).

This indicator varies depending on the control circuit setting (Fig. 2). The following parameters were introduced through the limitations of the study results. The current control value, relative to the standard scale, $I_{max}..I_{min}=4.1..19.9$ mA, the frequency of compressed air pulses formation in the product pipeline – 0.1...1.3 s. The pre-defined control signal values formed a maximum pressure in the pipe of 1.7...2.5 bar. This confirms the results reported in [11] and predetermines the optimal mode of pneumatic conveying of the examined product.

Special features of the proposed method and our results are that the theoretical model took into consideration the actual kinematic characteristics of individual particles of small-piece products and their possible contact with the inner surface of the product pipeline; a change in the geometric parameters of the product's pneumatic conveying channel.

Conditions of change in the characteristics of particles' movement after the impact interaction with the inner surface of the cylindrical part of the product pipeline are taken into consideration. We have derived the equations of their movement both at the surfaces of the cylinder and in the volume of the working channel as a whole.

For the stable operation of pneumatic conveying, a gas speed is recommended that exceeds by 1.5–2 times the rate of the hovering of a particle of the transported material (Fig. 5).

It has been established that the layer of small-piece product, permeated by the ascending stream of compressed air, can enter two qualitatively different stationary states. At a flow rate below 5 m/s, that is, some critical magnitude, particulate matter is stationary (Fig. 5). Pneumatic resistance increases with the speed of up to 15–20 m/s – the layer is suspended, particulates lose the previous mutual contact, are able to move and mix. The layer expands, waves and bursts are visible on its free surface (Fig. 3).

The analysis of our simulation results has shown that the following conclusion is fair – the total loss of pressure in the pipeline of pneumatic conveying consists of:

- the loss of pressure caused by the movement of clean air;
- additional pressure losses arising from the movement of the material;
- the loss of pressure to maintain the transported material in a suspended state on a vertical section;

– the loss of pressure to accelerate the transported particles when they are involved in the transport pipeline. The loss of pressure is directly proportional to the volume mass of air, the speed of its movement, and the weight concentration of the material in a mixture.

A certain limitation of this study is that it was carried out for only a few types of products from the small-piece group. The lack of complete experimental data for other types did not allow for a more detailed analysis of the effectiveness of the developed calculation methodology. This would be especially true for mixed products (mixes) with large-diameter particles (1 mm or larger), for which the curvature of the working channel in the diametric cross-section of the product pipeline could become a condition of congestion.

At the same time, the proposed approach makes it possible to derive similar dependences for other modes of transportation.

Further research is planned to analyze the processes of pneumatic conveying of other types of small-piece products. In our study, we selected the following values of pressure in the pneumatic conveying system: low pressure, up to 0.1 MPa; medium pressure, 0.11 to 0.3 MPa. It is necessary to investigate the behavior of the product in a product pipeline at a variable concentration of solid phase in the carrying stream, the flow rate mass concentration of up to 4 kg/kg. Investigating the perturbations of compressed air supply in the pneumatic product pipeline would make it possible to determine the rational regimes for certain groups of products.

7. Conclusions

1. We have obtained results from the experimental and theoretical studies of the process of transporting small-piece products in a working pneumatic product pipeline. The pressure in the working system is in the range of 2..4 bar, the flow speed is up to 20 m/s.

2. A control signal transmission scheme has been developed for the pulsed supply of compressed air in the vertical pipeline, taking into consideration the introduction of elements of the proportional pneumatic equipment (analog signal, 4.20 mA).

3. The rational parameters have been determined for both the control process and the process of transporting a product in

general. The particle radius is $r^*=3\cdot 10^{-3}$ (m); the density of a single particle of a small-piece product is $\rho^*=1.25\cdot 10^{-3}$ (kg·m⁻³); the air density is $\rho^*=1.24\cdot 10^{-3}$ (kg·m⁻³); the acceleration of free fall is $g=9.81$ (m·s⁻²); the maximum compressed air flow rate is $v_m=20$ (m·s⁻¹); the dynamic viscosity is $\mu=1.82\cdot 10^{-5}$ kg/(m·s); the radius of the pipe is $b=0.05$ m.

4. A mathematical model of the pneumatic conveying process of small-piece products has been developed. The model includes the differential motion equations for individual particles in the flow, as well as their behavior after colliding, with corresponding initial and boundary conditions. The boundary conditions take into consideration the influence of pneumatic conveying modes and the geometry of a product pipeline. The measured current value in mA (at a resolution of 0.001 mA) relative to the standard scale $I_{max}, I_{min}=4..20$ mA is registered in the ranges of 4.1 mA...19.9 mA; 12 mA...19.9 mA. The flow rate characteristic of the pneumatic valve in the installation is 180 Nl/min. The accepted function period duration is up to 0.3 s.

A mathematical model has been built for the movement of individual rotating particles to study the process of their collision with the walls of the product pipeline, taking into consideration the moment of particle inertia relative to the central axis, which is parallel to the Oz axis: $J = \left\{ \pi \cdot (2 \cdot r^*)^5 \rho^* \right\} / 60$.

5. We have substantiated a control model with the critical pneumatic conveying modes. The developed control models are based on the proportional elements and feedback (a current loop of 4–20 mA). The system generates a signal frequency of up to 500 Hz to the coil of the solenoid in an electromagnetic valve supplying compressed air into the vertical channel system of the product pipeline. The power voltage in the control chain is 24 VDC ($\pm 10\%$) in accordance with the selected proportional distributor AP. The flow rate of compressed air will depend on the value of incoming mainline pressure P (0.1...0.3 MPa), and, according to data reported in [17, 18], are 80...160 (Nl/min).

Acknowledgments

We express our gratitude to the company CAMOZZI for providing the control and measurement equipment.

References

1. Raheman, H., Jindal, V. K. (2001). Pressure drop gradient and solid friction factor in horizontal pneumatic conveying of agricultural grains. *Applied Engineering in Agriculture*, 17 (5). doi: <https://doi.org/10.13031/2013.6903>
2. Raheman, H., Jindal, V. K. (2001). Solid velocity estimation in vertical pneumatic conveying of agricultural grains. *Applied Engineering in Agriculture*, 17 (2). doi: <https://doi.org/10.13031/2013.5446>
3. Cui, H., Grace, J. R. (2006). Pneumatic conveying of biomass particles: a review. *China Particology*, 4 (3-4), 183–188. doi: [https://doi.org/10.1016/s1672-2515\(07\)60259-0](https://doi.org/10.1016/s1672-2515(07)60259-0)
4. Tymoshenko, V. I., Knyshenko, Yu. V. (2013). Granular material pneumatic transportation under increased pressure of carrier gas. *Nauka ta innovacii*, 9 (1), 5–17. doi: <https://doi.org/10.15407/scin9.01.005>
5. Kril', S. I., Chal'tsev, M. N. (2010). About method of calculating main parameters of pneumatic transport ulk solids in horizontal pipes. *Prykladna hidromekhanika*, 12 (4), 36–44.
6. Dixon, G.; Butters, G. (Ed.) (1981). Chap. Pneumatic conveying. *Plastics Pneumatic Conveying and Bulk Storage*. Applied Sciences Publisher.
7. Gyenis, J., Arva, J. (1994). Steady state particle flow in mixer tubes equipped with motionless mixer elements. *Industrial Mixing Technology*, 144–160.

8. Orozovic, O., Lavrinec, A., Rajabnia, H., Williams, K., Jones, M. G., Klinzing, G. E. (2020). Transport boundaries and prediction of the slug velocity and layer fraction in horizontal slug flow pneumatic conveying. *Chemical Engineering Science*, 227, 115916. doi: <https://doi.org/10.1016/j.ces.2020.115916>
9. Zhang, P., Roberts, R. M., Bénard, A. (2012). Computational guidelines and an empirical model for particle deposition in curved pipes using an Eulerian-Lagrangian approach. *Journal of Aerosol Science*, 53, 1–20. doi: <https://doi.org/10.1016/j.jaerosci.2012.05.007>
10. Röhrig, R., Jakirlić, S., Tropea, C. (2015). Comparative computational study of turbulent flow in a 90° pipe elbow. *International Journal of Heat and Fluid Flow*, 55, 120–131. doi: <https://doi.org/10.1016/j.ijheatfluidflow.2015.07.011>
11. Li, K., Kuang, S. B., Pan, R. H., Yu, A. B. (2014). Numerical study of horizontal pneumatic conveying: Effect of material properties. *Powder Technology*, 251, 15–24. doi: <https://doi.org/10.1016/j.powtec.2013.10.013>
12. Yang, D., Li, J., Du, C., Jiang, H., Zheng, K. (2015). Injection Performance of a Gas-Solid Injector Based on the Particle Trajectory Model. *Advances in Materials Science and Engineering*, 2015, 1–8. doi: <https://doi.org/10.1155/2015/871067>
13. Gavva, O., Kryvoplias-Volodina, L., Yakymchuk, M. (2017). Structural-parametric synthesis of hydro-mechanical drive of hoisting and lowering mechanism of package-forming machines. *Eastern-European Journal of Enterprise Technologies*, 5 (7 (89)), 38–44. doi: <https://doi.org/10.15587/1729-4061.2017.111552>
14. Vasilevskiy, M. V., Romandin, V. I., Zykov, E. G. (2013). *Transportirovka i osazhdenie chastits v tehnologiyah pererabotki dispersnyh materialov*. Tomsk: Izd-vo Tomskogo politehnicheskogo universiteta, 288.
15. Shishkin, S. F., Gavrilyuk, D. N. (2009). Raschet vysokonapornogo pnevmotransporta. *Vestnik BGTU im. V.G. SHuhova*, 3, 114–117.
16. Berger, S. A., Talbot, L., Yao, L. S. (1983). Flow in Curved Pipes. *Annual Review of Fluid Mechanics*, 15 (1), 461–512. doi: <https://doi.org/10.1146/annurev.fl.15.010183.002333>
17. Ghafari, H., Ebrahimi, H. R. (2018). Numerical and experimental study of an innovative pipeline design in a granular pneumatic-conveying system. *Particuology*, 38, 196–203. doi: <https://doi.org/10.1016/j.partic.2017.07.007>
18. de Moraes, M. S., Torneiros, D. L. M., da Silva Rosa, V., Higa, J. S., De Castro, Y. R., Santos, A. R. et. al. (2017). Experimental quantification of the head loss coefficient K for fittings and semi-industrial pipe cross section solid concentration profile in pneumatic conveying of polypropylene pellets in dilute phase. *Powder Technology*, 310, 250–263. doi: <https://doi.org/10.1016/j.powtec.2017.01.039>
19. Rajan, K. S., Srivastava, S. N., Pitchumani, B., Dhasandhan, K. (2008). Experimental study of thermal effectiveness in pneumatic conveying heat exchanger. *Applied Thermal Engineering*, 28 (14-15), 1932–1941. doi: <https://doi.org/10.1016/j.applthermaleng.2007.12.004>
20. Zhang, H., Liu, M., Wang, B., Wang, X. (2011). Dense gas-particle flow in vertical channel by multi-lattice trajectory model. *Science China Technological Sciences*, 55 (2), 542–554. doi: <https://doi.org/10.1007/s11431-011-4578-7>