

Experimental studies of change in the air temperature in a power unit with a prototype RPD-4.4/1.75 rotary-piston pneumatic motor were carried out to solve the problem of the negative impact of low temperatures of exhaust air on the pneumatic motor performance.

It has been established that an increase in rpm by 62 % leads to a drop of air temperature after reducer by 33 %. In this case, the maximum temperature drop during throttling is 21 K under conditions of maximum rpm and pressure of 0.8 MPa in the inlet receiver. It was found that under experimental conditions, the average differential Joule-Thomson effect is in the range of 0.8...3.9 K/MPa when throttling in the reducer for the pressure range of 0.4...0.8 MPa in the inlet receiver.

It was found that the temperature drop caused by air expansion in the working cylinder of the pneumatic motor is about 22 K in absence of regulation of the filling degree. At the same time, temperature fluctuations do not exceed 4.5 % depending on the change in the motor rpm and pressure in the inlet receiver.

A maximum temperature decrease in the power unit was obtained experimentally. Under the experimental conditions and depending on the study mode, the temperature drop from the initial storage value is from 35 to 43 K.

It was found that the amount of energy required for heating air at the inlet to the inlet receiver with a pressure of 0.6 MPa in the air storage temperature range of $-5...-20$ °C is 0.14...1.99 kW. In this case, the ratio Q_p/Ne can reach 0.1...0.58, that is, in some operating modes, more than half of the produced power will actually be spent on air heating. Accordingly, the results obtained are useful and necessary when choosing conditions and operating modes of the pneumatic motor

Keywords: rotary piston pneumatic motor, storage pressure, Joule-Thomson effect, air heating

Received date 02.11.2020

Accepted date 07.12.2020

Published date 21.12.2020

1. Introduction

Pneumatic motors of various types are widely used as a drive for various mechanisms and machines in many industries: shipbuilding, transport, construction, and in production of hand tools. Design and operational features of pneumatic motors make them indispensable in explosive-related industries and in conditions in which the use of electric motors can lead to electric shock to workers. For example, pneumatic motors are used in hazardous areas such as chemical, petrochemical, and mining industries. In addition, pneumatic motors have a fairly low relative mass, are not afraid of overloads, feature a fairly simple design which ensures their reliability in operation and low cost in manufacturing.

One of the problems when using pneumatic motors is a significant decrease in the temperature of the spent working medium in comparison with the initial storage temperature. For example, a decrease in temperature of the working medium is observed:

- when throttling the working medium from storage pressure in cylinders to the required operating pressure in the engine receiver (Joule–Thomson effect);

- when expanding in the working cylinder of the engine (Siemens–Claude effect).

UDC 621.438

DOI: 10.15587/1729-4061.2020.217239

DETERMINING A CHANGE IN THE COMPRESSED AIR TEMPERATURE DURING THE OPERATION OF A ROTARY PISTON ENGINE

O. Mytrofanov

PhD, Associate Professor*

E-mail: oleksandr.mytrofanov@nuos.edu.ua

A. Proskurin

PhD, Associate Professor*

E-mail: arkadii.proskurin@nuos.edu.ua

*Department of Internal Combustion Engines,
Plants and Technical Exploitation
Admiral Makarov National University
of Shipbuilding
Heroiv Ukrainy ave., 9, Mykolaiv, Ukraine, 54025

Copyright © 2020, O. Mytrofanov, A. Proskurin

This is an open access article under the CC BY license

(<http://creativecommons.org/licenses/by/4.0>)

Compressed air storage pressure can reach 30...40 MPa while the working pressure of most pneumatic motors is about 0.4...1.0 MPa. Accordingly, to provide the required operating pressure before the pneumatic motor, the compressed air is subjected to throttling in a special reducer. In the process of throttling, not only the air pressure decreases to the operating value but its temperature as well. Depending on its initial value after throttling in a reducer, the compressed air temperature can already be negative before expansion in the pneumatic motor. Accordingly, after expansion in the pneumatic motor, the temperature of the exhaust air can fall below the permissible values that ensure the operability of this pneumatic motor. At the same time, with a decrease in the initial temperature and an increase in the initial pressure (temperature and pressure of compressed air storage), the cooling effect increases during throttling.

First of all, the relevance of scientific studies in this area is associated with the fact that a significant decrease in the exhaust air temperature negatively affects the efficiency of the pneumatic motor [1–3]. For example, a drop in temperature below permissible values can lead to a violation of lubrication regimes of rubbing parts and the growth of mechanical losses up to the pneumatic motor jamming. In addition, a decrease in temperature causes the icing of the exhaust channels and

the gas exhaust system in general. In its turn, this leads to a decrease in power and an increase in consumption of the working medium. Freezing of the pneumatic motor exhaust system also causes a significant increase in noise level.

The practical results of this study direction can serve as recommendations regarding the optimal temperature level of the working medium at the inlet and outlet of the pneumatic motor, which will ensure efficient operation in various operating conditions.

2. Literature review and problem statement

Theoretical studies in the field of effect of low temperatures are given in [4]. For example, the negative effect of low temperature on the effective performance of the pneumatic motor was shown based on the thermodynamic analysis. A significant decrease in temperature leads to an increase in the flow rate of the working medium up to 40 % and a drop in the effective power of the pneumatic motor. However, the issues related to a possible solution to the problem of low temperatures have remained unresolved in this study. Since the presented results were obtained by mathematical modeling (without taking into account real processes), they can be used only as a first approximation in the analysis of the operation of pneumatic motors.

The issues of designing and using pneumatic motors for transport power units and associated problems were considered in [5]. In particular, the issue of low temperatures resulting from the adiabatic expansion in the working cylinder of the pneumatic motor and its negative effect on the amount of released useful energy was raised. However, the study lacks data linking operational and design parameters of the pneumatic motor with a decrease in temperature. In addition, the influence of the storage pressure of compressed air on the temperature drop caused by throttling to the operating pressure of the pneumatic motor has remained undisclosed.

The initial pressure of compressed air in supply cylinders also has an effect on the final temperature of the air before entering the engine. For example, an analysis of the influence of the initial pressure of compressed air on the change in temperature and power of the rotary pneumatic motor was made in work [6]. It has been found that temperature at the outlet of the pneumatic motor can reach values up to $-122.5\text{ }^{\circ}\text{C}$, which is unacceptable. The cause of such low temperatures is the use of a rotary engine and its operating cycle features.

Introduction of additional heating of the working medium before expansion in the pneumatic motor may be one of the options for overcoming corresponding difficulties associated with low temperatures. For example, this approach is used in [7–9] where it is proposed to use natural gas for preheating compressed air. The use of an additional source of energy for air heating is impractical since it significantly reduces the efficiency of the power generating unit. Power generating units that accumulate thermal energy during compression and subsequently use it to heat up compressed air before expansion are more promising [10–12]. The use of such structurally complex installations is limited to stationary ones and cannot be implemented, for example, in transport installations.

The amount of required heating directly depends on a series of factors. For example, the initial temperature of the working medium, in fact, the storage temperature (which is usually equal to the ambient temperature) as well as the storage pressure and value of required pressure of the working medium at the inlet to the expansion machine have a big

influence. The issues of determining the required degree of heating of compressed air at the inlet to the pneumatic motor based on initial pressure and temperature of the air in cylinders are considered in [13]. At the same time, the study does not consider the issue of temperature reduction as a result of expansion in the working cylinder.

Besides, heating of the working medium makes it possible to improve the effective performance of the pneumatic motor. Experimental characteristics of changes in effective indicators of a pneumatic four-cylinder piston motor with a slide air distribution with and without air heating at the inlet were analyzed in [14]. It was found that air heating has a positive effect on energy and economic indicators, namely, an increase in power and a decrease in specific effective consumption of compressed air was observed. A change in parameters of the pneumatic motor in terms of speed characteristics when heating air at the inlet was considered in [15]. The author noted that with the introduction of heating, reliability, and durability of the engine increases due to improved lubrication conditions for the parts of the cylinder-piston group and the absence of icing of the exhaust channels. A positive effect of heating air at the inlet was also noted in [16]. The author focused on improved exergy effective efficiency and reliability of the automobile pneumatic motor. However, the issue of the required amount of energy supplied for heating and accounting for the costs remained open in [14–16].

Heating of the working medium is directly connected with high energy consumption and complication of the power unit design. Undoubtedly, it is rational to use the heat of secondary energy resources, for example, such as exhaust gases of an internal combustion engine as it was proposed in [16].

There are known recommendations regarding the theoretical calculation of exhaust air temperature at the outlet of the pneumatic motor but there are practically no recommendations regarding its permissible level. The lack of practical recommendations regarding the minimum exhaust air temperature is primarily explained by the significant difference between theoretical and actual temperature values. The difference between actual and theoretical temperatures of the exhaust air is associated with a number of factors, which cannot be fully taken into account in mathematical modeling. For example, the value of final temperature is influenced by air flow rate, heat exchange in the working space and other elements of the engine, presence of moisture in compressed air, as well as the design of the pneumatic motor and its gas exchange organs. These factors and a series of others can be taken into account by conducting experimental studies of pneumatic motors in various modes and operating conditions.

The RPD-4.4/1.75 rotary piston engine [17] is a volumetric expansion machine in which it is possible to efficiently convert the energy of a compressed working medium (various gases) into mechanical energy of the output shaft rotation. Despite the large number of studies devoted to the study of the working process of pneumatic motors, the issue of the minimum temperature of a rotary piston pneumatic motor is left open. First of all, this is because of the fact that the rotary piston pneumatic motor is a prototype with its design differing from classical engines and therefore the existing recommendations can only be partially used for this pneumatic motor. All this allows us to assert that it is expedient and promising to conduct experimental and theoretical studies on changes in temperature of the working medium as well as the effect of heating on the pneumatic motor operation. It is also necessary to elaborate practical recommendations regarding features of operation of

the pneumatic motor at low temperatures and possible heating of the working medium before its expansion.

3. The aim and objectives of the study

The study objective is to determine a change in the working medium temperature during the full cycle of energy conversion in a power unit with a rotary piston pneumatic motor RPD-4.4/1.75, which will make it possible to assess the performance of the pneumatic motor at low temperatures.

To achieve the objective, the following tasks were set:

- to determine the influence of operating parameters of a rotary piston pneumatic motor and a compressed air storage system on change in air temperature during the throttling process;
- to determine the influence of operating parameters of a rotary piston pneumatic motor on change in temperature of the air during its expansion in the working cylinder and estimate the total drop in temperature of compressed air in the process of energy conversion;
- to evaluate the pneumatic motor performance at low temperatures of compressed air storage and determine the required degree of heating air before its expansion in the working cylinder.

4. Materials and methods used in studying the changes in the temperature of compressed air in the process of energy conversion

The study of features of change in temperature of compressed air in the process of energy conversion from the stage of storage to the release into the environment in a power unit with a rotary-piston pneumatic motor RPD-4.4/1.75 was carried out by the method of physical modeling. Physical modeling of a prototype will make it possible to obtain data on the performance of the pneumatic motor at low temperatures in various operating modes, as well as assess the required degree of heating air before its expansion. The results of experimental studies will form a basis for the development of practical recommendations regarding the operation and maintenance of rotary piston pneumatic motors.

The processes of throttling and expansion in a power unit are the study object. Experimental characteristics of change in air temperature from the initial storage value to the final value of exhaust air are the study subject.

Experimental studies of changes in temperature of compressed air during operation of a rotary piston engine were carried out on the basis of the experimental bench described in [18]. The gas exhaust system was modified in the experimental bench which has made it possible to ensure an acceptable level of exhaust noise, as well as bring the experimental conditions closer to real operating conditions. Photos and a diagram of the modified experimental bench are shown in Fig. 1, 2, respectively.

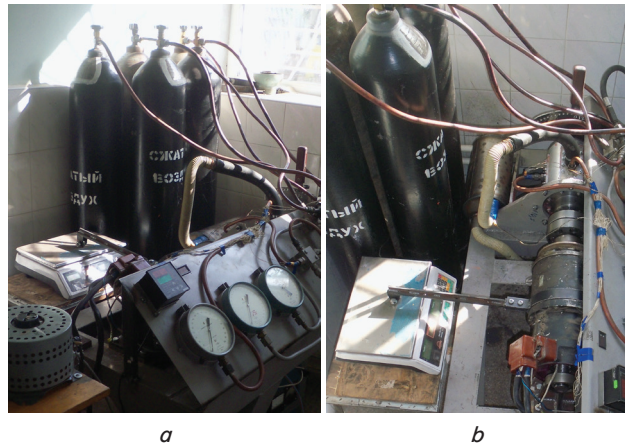

Fig. 1. Experimental bench built on the basis of the prototype rotary-piston pneumatic motor RPD-4.4/1.75: *a* – general view of the instrument panel of the experimental bench; *b* – the pneumatic motor in assembly with an electric generator

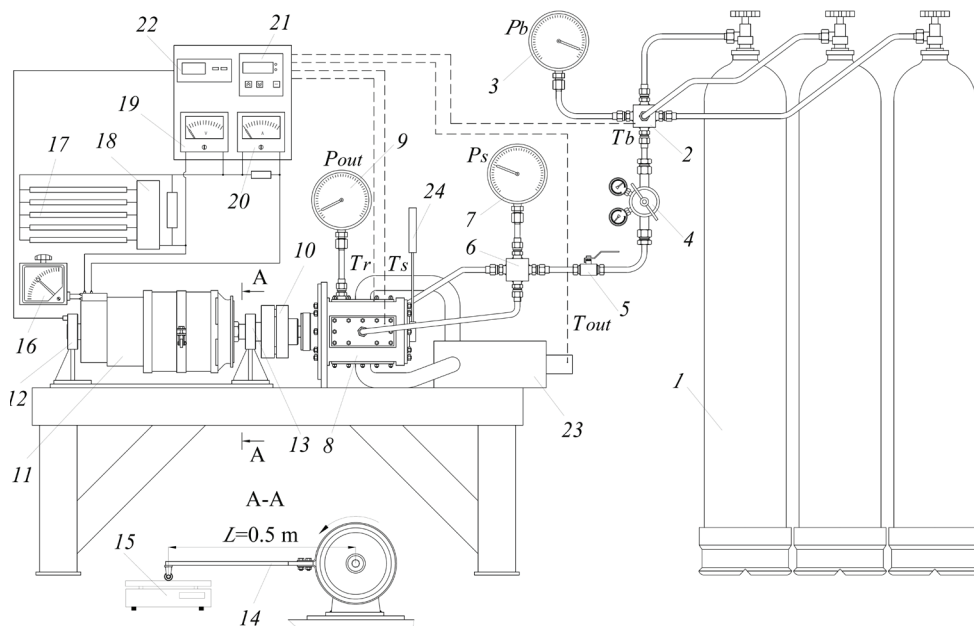

Fig. 2. Schematic diagram of the power unit with a rotary piston pneumatic motor RPD-4.4/1.75: 1 – compressed air cylinders; 2 – high-pressure distributor; 3 – pressure gauge for measuring pressure in cylinders; 4 – air reducer; 5 – shut-off valve; 6 – low-pressure distributor; 7 – pressure gauge for measuring pressure in intake receivers of the engine; 8 – RPD-4.4/1.75 rotary piston engine; 9 – pressure gauge for measuring pressure in exhaust receivers of the engine; 10 – sleeve-finger coupling for connecting the engine and generator; 11 – GS-24A generator; 12 – left support of the generator end; 13 – right support of the generator end; 14 – lever for determining the torque; 15 – scales; 16 – generator load control; 17 – block of heating elements; 18 – heating element control unit; 19 – voltmeter; 20 – ammeter; 21 – OWEN UKT38-ShCh4.TP multipurpose eight-channel measuring regulator; 22 – tachometer; 23 – noise muffler; 24 – lever for adjusting the position of the camshaft (adjusting the degree of filling)

In experimental tests of the RPD-4.4/1.75 rotary-piston pneumatic motor, storage pressure was 14 MPa, and temperature corresponded to ambient temperature. Depending on the test mode, working air pressure in the inlet receiver of the pneumatic motor was in a range of 0.4...0.8 MPa.

The pneumatic motor speed and air pressure in the intake receiver (operating pressure) are the operating parameters of a rotary piston pneumatic motor that have the most influence on the change in air temperature. Storage temperature and pressure are the defining parameters of the compressed air storage system. Proceeding from this, the experimental studies of changes in temperature of compressed air were carried out taking into account these parameters.

5. Results of experimental studies into the changes in air temperature in the process of energy conversion in a power unit

5.1. Studying the influence of operating parameters of a pneumatic motor on a change in the air temperature during throttling

The storage pressure of air in cylinders can exceed 35 MPa while the operating pressure of the pneumatic motor is usually 0.4...1.0 MPa. Accordingly, it becomes necessary to reduce air pressure to operating values by throttling in the gas reducer. In this case, along with a decrease in air pressure, its temperature also decreases (the Joule-Thomson effect). Fig. 3 shows experimental results of the change in temperature of compressed air as a result of throttling in the gas reducer. The value of ΔT_p depends on initial values of pressure P_b and storage temperature T_b , final reduction pressure P_s and the airflow rate which in turn is related to the engine speed n . For example, according to the results obtained, the maximum temperature drop at a pressure in the inlet receiver of 0.8 MPa will be approximately $\Delta T_p=21$ K. Moreover, with an increase in engine speed from minimum to maximum (an increase in the hourly consumption of compressed air and, accordingly, an increase in the flow rate), the temperature drop increases by about 7 K.

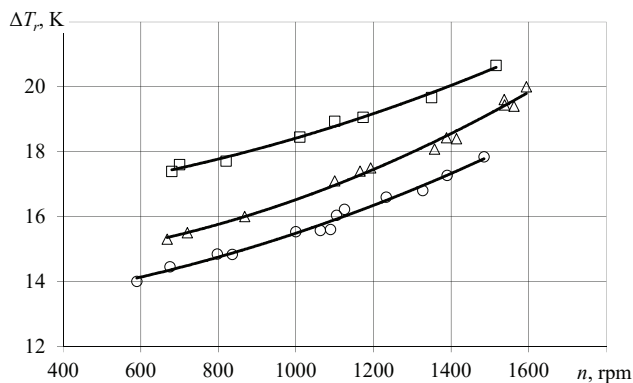

Fig. 3. Change in the value of compressed air temperature drop ΔT_p during throttling in the gas reducer depending on the operating pressure P_s in the inlet receiver and engine speed n : \square for $P_s=0.8$ MPa; Δ for $P_s=0.6$ MPa; \circ for $P_s=0.4$ MPa

Since when throttling in the gas reducer, temperature decreases with a significant drop in compressed air pres-

sure, the integral Joule-Thomson effect is determined by the law [13, 19]:

$$\Delta T_i = T_1 - T_2 = \int_{P_1}^{P_2} \alpha_i dP = \alpha_i \Delta P, \text{ K,}$$

whence the differential effect of throttling α_i .

$$\alpha_i = \frac{\Delta T_i}{\Delta P}, \text{ K/MPa}$$

where T_1, T_2 are the temperature values before and after the reducer, K; P_1, P_2 are the pressure values before and after the reducer, MPa.

Fig. 4 shows the change in average differential Joule-Thomson effect α_i when throttling in the gas reducer depending on operating pressure P_s in the inlet receiver and pressure P_b in the cylinder.

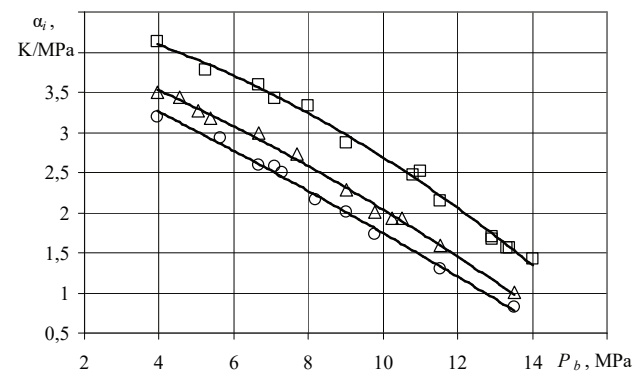

Fig. 4. Change in the average differential Joule-Thomson effect during throttling in the gas reducer for different values of the working pressure in the inlet receiver P_s depending on the air pressure in the cylinder: \square for $P_s=0.8$ MPa; Δ for $P_s=0.6$ MPa; \circ for $P_s=0.4$ MPa

According to the conditions of experimental studies of the RPD-4.4/1.75 rotary-piston pneumatic motor, the value of α_i is within 0.8...3.9 K/MPa.

5.2. Studying the influence of operating parameters of the pneumatic motor on change in air temperature during expansion

Fig. 5 shows a change in the value of the compressed air temperature drop ΔT_d during expansion in the pneumatic motor working cylinder taking into account the rotor speed n , as well as temperature T_s and pressure P_s in the intake receiver. According to the experimental data obtained, the temperature drop at the end is approximately 22 K. It should be noted that the change in engine speed has an insignificant effect on temperature drop during air expansion and is within 1 K.

The total value of exhaust air temperature drop T_{out} is shown in Fig. 6. In accordance with the operating mode of the rotary piston engine, the total temperature drop from the initial storage value in the cylinder T_c is 35 to 43 K.

Thus, when the engine is operating under conditions of positive values of the compressed air storage temperature, additional heating of the working medium at the inlet is not required from the point of view of ensuring operability. Additional heating can only be considered in terms of improving energy conversion.

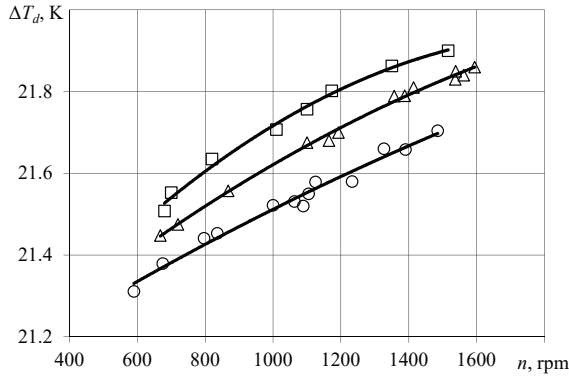

Fig. 5. Change in the value of compressed air temperature drop ΔT_d during air expansion in the working cylinder depending on operating pressure in the intake receiver P_s and the engine speed n : \square for $P_s=0.8$ MPa; Δ for $P_s=0.6$ MPa; \circ for $P_s=0.4$ MPa

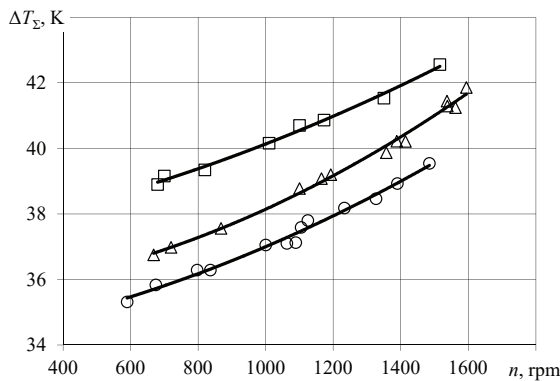

Fig. 6. Change in the value of total compressed air temperature drop T_{out} depending on operating pressure P_s in the inlet receiver and the engine speed n : \square for $P_s=0.8$ MPa; Δ for $P_s=0.6$ MPa; \circ for $P_s=0.4$ MPa

5. 3. Studying the effect of low temperatures of compressed air storage on the pneumatic motor operability

When operating a rotary piston pneumatic motor under negative temperatures, it becomes necessary to introduce additional heating of compressed air at the inlet to the intake receiver. First of all, this is connected with ensuring normal lubrication and preventing icing of the engine exhaust tract. Fig. 7 shows the change in exhaust air temperature T_{out} depending on air storage temperature T_b and the engine speed n . Pressure in the receiver was 0.6 MPa. In accordance with the data obtained, the minimum storage temperature T_b at which the engine can still operate without heating is 0...- 5 °C.

To determine the required amount of supplied energy Q_h for heating compressed air at $P_s=0.6$ MPa, the temperature limit value in the intake receiver was set at $T_s=0$ °C. The value of temperature T_s was selected taking into account the provision of reliable, trouble-free, and efficient operation of the pneumatic motor. Fig. 8 shows the change in Q_h depending on T_b and n , while the exhaust air temperature does not exceed $T_{out}=42$ °C. According to the data obtained, the heating degree for the temperature range $T_b=-5...-20$ °C will be $Q_h=0.14...1.99$ kW.

When analyzing the results obtained in relation to the required amount of energy supplied for heating compressed air, it is possible to draw conclusions about the low efficiency of using a rotary-piston pneumatic motor at subzero

temperatures. The decrease in efficiency of the pneumatic motor is explained by the fact that in order to ensure its normal functioning, it is necessary to take off a part of the produced power for air heating. The amount of power taken-off directly depends on the operating mode and storage temperature of compressed air (Fig. 9). So, the ratio Q_h/N_e is in the range of 0.11...0.58 depending on T_b and n for the mode $P_s=0.6$ MPa. In this case, the highest value corresponds to the maximum load and temperature $T_b=-20$ °C.

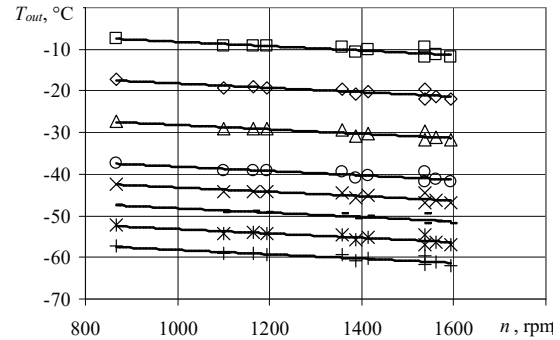

Fig. 7. Change in exhaust air temperature T_{out} depending on air storage temperature T_b and engine speed n for the test mode: $P_s=0.6$ MPa: \square for $T_b=30$ °C; \diamond for $T_b=20$ °C; Δ for $T_b=10$ °C; \circ for $T_b=0$ °C; $T_b=-5$ °C; $T_b=-10$ °C; $T_b=-15$ °C; $T_b=-20$ °C

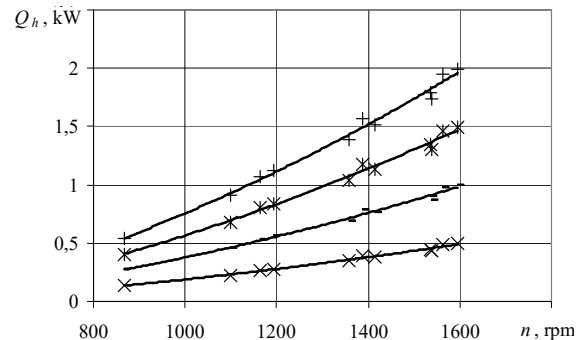

Fig. 8. The change in the required amount of supplied energy Q_h for heating compressed air at the inlet to the inlet receiver depending on air storage temperature T_b and engine speed n for the test mode $P_s=0.6$ MPa: \times for $T_b=-5$ °C; $+$ for $T_b=-10$ °C; \times for $T_b=-15$ °C; $+$ for $T_b=-20$ °C

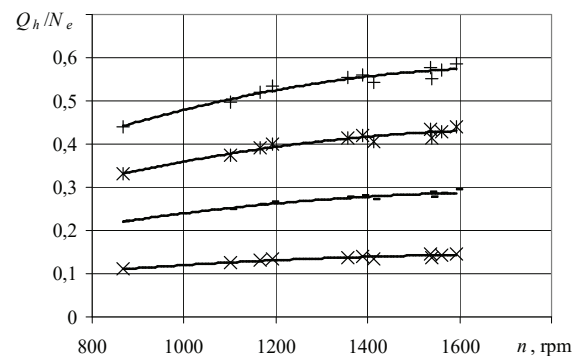

Fig. 9. Change in the ratio of the required amount of energy supplied for heating compressed air to the effective power of the rotary piston engine: \times for $T_b=-5$ °C; $+$ for $T_b=-10$ °C; \times for $T_b=-15$ °C; $+$ for $T_b=-20$ °C

A certain solution to the problem of low temperatures without consuming power of the rotary piston pneumatic mo-

tor itself can be its use as a part of a power unit together with a heat-producing engine (for example, an internal combustion engine, ICE). In this case, the heat of the ICE exhaust gases can be used to heat compressed air at the inlet to the intake receiver. Such a scheme of using a pneumatic motor as a part of a hybrid power unit for cars was reflected in the patent [20].

6. Discussion of the results obtained in the study of changes in temperature of compressed air in the process of energy conversion

According to the experimental data presented in Fig. 3, temperature drop increases with an increase in the speed of the pneumatic motor. The results obtained are explained, first of all, by an increase in flow rate and airflow rate in channels and pipelines of the air system of the pneumatic motor. With an increase in the initial pressure of compressed air, a decrease in the average differential Joule-Thomson effect is observed when throttling in a gas reducer (Fig. 4). This is explained by an increase in pressure drop.

In contrast to throttling, the effect of rpm on reducing the air temperature during air expansion in the working cylinder is insignificant (Fig. 5) and amounts to about one degree. The results obtained are explained by the lack of regulation of the degree of filling and the degree of expansion during experimental studies.

In conditions of subzero temperatures of storage of compressed air, a decrease in efficiency of using a rotary piston pneumatic motor is observed (Fig. 9). This is explained by the fact that a part of generated energy will be spent on air heating.

The results obtained make it possible to estimate the permissible value of the exhaust air temperature depending on the mode and operating conditions of the rotary piston pneumatic motor and determine the degree of required heating in conditions of subzero air storage temperatures.

Proceeding from the experimental data obtained, a distinctive feature of the presented pneumatic motor consists in that it remains operational and does not require additional air heating to the compressed air storage temperature up to -5°C . For comparison, the value of air temperature after the gas reducer (before the engine) recommended in [13] should not be lower than -5°C . The efficiency of a rotary piston pneumatic motor at subzero values of air storage is achieved due to design features, namely, the mechanism of motion and gas distribution.

The results of experimental studies are limited by the range of pressure variation in the inlet receiver within 0.4...0.8 MPa and the compressed air storage pressure of 14 MPa. This must be taken into account when operating the pneumatic motor.

Proceeding from this prerequisite, it is of practical interest to conduct experimental studies for pressures in the inlet receiver and in the supply cylinders that differ from the indicated values. In addition, carrying out some additional experimental tests requires a study of the influence of the degree of filling and the degree of expansion on the air temperature change in the pneumatic motor.

Development of circuitry for utilizing cold or using secondary energy resources for heating compressed air in power units for various purposes, e.g. as suggested in [20] is a promising development of this study direction.

7. Conclusions

1. It was experimentally established that an increase in the speed of a rotary piston pneumatic motor by 62 % leads to a 33 % decrease in air temperature after the reducer. In this case, the maximum drop in air temperature during throttling under conditions of maximum speed and $P_s=0.8$ MPa is $\Delta T_i=21$ K. It was determined that under the experimental conditions, the average differential Joule-Thomson effect when throttling in a gas reducer is within $\alpha_i=0.8...3.9$ K/MPa for the range $P_s=0.4...0.8$ MPa.

2. It has been established that the temperature decrease caused by an expansion in the working cylinder of the rotary piston engine in absence of regulation of the degree of filling measures about 22 K. At the same time, temperature fluctuations do not exceed 4.5 % depending on the change in rpm and pressure in the intake receiver. The maximum temperature decrease from the initial value of storage in the cylinder of the power unit with the RPD-4.4/1.75 rotary-piston pneumatic motor is 35...43 K under the experimental conditions and depending on the mode of experiment conduction.

3. It has been established that the amount of energy required for heating air at the inlet to the inlet receiver with a working pressure of 0.6 MPa is 0.14...1.99 kW for the compressed air storage temperature within $-5...-20^{\circ}\text{C}$. In this case, the ratio Q_i/N_e can reach 0.11...0.58, that is, more than half of the power produced by a rotary piston pneumatic motor will actually be spent on air heating.

References

1. Degtiarev, V. I., Mialkovskii, V. I., Borisenko, K. S. (1979). *Shakhtnye pnevmomotory*. Moscow: Nedra, 192.
2. Zinevich, V. D., Iarmolenko, G. Z., Kalita, E. G. (19575). *Pnevmaticheskie dvigateli gornyx mashin*. Moscow: Nedra, 344.
3. Zinevich, V. D., Geshlin, L. A. (1982). *Porshnevye i shesterenny pnevmodvigateli gornoshakhtnogo oborudovaniia*. Moskva: Nedra, 200.
4. Yuan, Q., Guo, Z., Xie, X., Li, W., Duan, Q., Hao, H. (201). Effects of Low Temperature on Performance of Reciprocating Pneumatic Motor. *International Conference on Computer, Mechatronics and Electronic Engineering (CMEE)*, 672–677. doi: <http://doi.org/10.12783/dtce/cmee2017/20055>
5. Verma, S. S. (2013). Latest Developments of a Compressed Air Vehicle: A Status Report. *Global Journal of Researches in Engineering Automotive Engineering*, 13 (1), 14–23. Available at: https://globaljournals.org/GJRE_Volume13/2-Latest-Developments-of-a-Compressed-Air.pdf
6. Szablowska, Ł., Milewski, J. (2011). Dynamic analysis of compressed air energy storage in the car. *Journal of Power Technologies*, 91 (1), 23–36. Available at: <http://papers.itc.pw.edu.pl/index.php/JPT/article/view/196>
7. Liu, C., Xu, Y., Hu, S., Chen, H. (2015). Techno-economic analysis of compressed air energy storage power plant. *Energy Storage Science and Technology*, 4, 158–168. Available at: <http://www.energystorage-journal.com/EN/10.3969/j.issn.2095-4239.2015.02.006>

8. Wang, J., Lu, K., Ma, L., Wang, J., Dooner, M., Miao, S. et. al. (2017). Overview of Compressed Air Energy Storage and Technology Development. *Energies*, 10 (7), 991. doi: <http://doi.org/10.3390/en10070991>
9. Diyoke, C., Aneke, M., Wang, M., Wu, C. (2018). Techno-economic analysis of wind power integrated with both compressed air energy storage (CAES) and biomass gasification energy storage (BGES) for power generation. *RSC Advances*, 8 (39), 22004–22022. doi: <http://doi.org/10.1039/c8ra03128b>
10. Budt, M., Wolf, D., Span, R., Yan, J. (2016). A review on compressed air energy storage: Basic principles, past milestones and recent developments. *Applied Energy*, 170, 250–268. doi: <http://doi.org/10.1016/j.apenergy.2016.02.108>
11. Sciacovelli, A., Li, Y., Chen, H., Wu, Y., Wang, J., Garvey, S., Ding, Y. (2017). Dynamic simulation of Adiabatic Compressed Air Energy Storage (A-CAES) plant with integrated thermal storage – Link between components performance and plant performance. *Applied Energy*, 185, 16–28. doi: <http://doi.org/10.1016/j.apenergy.2016.10.058>
12. Guo, Z., Deng, G., Fan, Y., Chen, G. (2016). Performance optimization of adiabatic compressed air energy storage with ejector technology. *Applied Thermal Engineering*, 94, 193–197. doi: <http://doi.org/10.1016/j.applthermaleng.2015.10.047>
13. Voronkov, A. I., Teslenko, E. V., Udovik, T. A. (2016). Opredelenie minimalno neobkhodimogo podogreva szhatogo vozdukha na vkhode v avtomobilnii pnevmodvigatel pri razlichnykh usloviakh ekspluatatsii. *Vestnik KHNADU*, 75, 100–108.
14. Voronkov, A. I., Nikitchenko, I. N. (2016). Influence of compressed heated air on effective performance of the pneumoengine workflow. *Internal Combustion Engines*, 2, 19–24. doi: <http://doi.org/10.20998/0419-8719.2016.2.04>
15. Voronkov, A. I. (2015). Izmenenie po skorostnym kharakteristikam pokazatelei rabocheho protsessa pri podogreve szhatogo vozdukha na vkhode v pnevmodvigatel. *Vestnik KHNADU*, 71, 13–16.
16. Voronkov, A. I. (2016). Vliianie podogreva szhatogo vozdukha na eksergeticheskii effektivnii KPD i nadezhnost raboty avtomobilnogo pnevmaticheskogo dvigatelja. *Vestnik TADI*, 2/3, 42–46.
17. Mytrofanov, O. S., Shabalin, Yu. V., Biriuk, T. F., Yefenina, L. O. (2019). Pat. No. 120489 UA. Porshneva mashyna. MPK: A23C 19/00. No. a201902189; declared: 10.09.2019; published: 10.12.2019, Bul. No. 23.
18. Mytrofanov, O. S. (2019). Stand for test and research of rotor-piston engines. *Collection of Scientific Publications NUS*, 1 (475), 51–57. doi: [http://doi.org/10.15589/znp2019.1\(475\).7](http://doi.org/10.15589/znp2019.1(475).7)
19. Anurov, S. A. (2017). Kriogennye tekhnologii razdeleniia gazov. Moscow: OOO «AR-Konsalt», 233. Available at: <http://co2b.ru/uploads/mon.2017.08.01.pdf>
20. Voronkov, O. I., Nikitchenko, I. M., Teslenko, E. V., Linkov, O. Yu., Nazarov, A. O. (2015). Pat. No. 101604 UA. Kombinovana sylova ustanovka avtotransportnoho zasobu. MPK: 7 V60K 6/00 V60K 5/00 F28C 3/00. No. u201502228; declared: 13.03.2015; published: 25.09.2015, Bul. No. 18.