

AC electric arc furnaces (EAFs) are among the most common technological units for making high-quality steel. The use of furnaces is promising in the future as the production volumes of electric steel increase. These furnaces are powerful electrical installations exposed to the dynamic, asymmetrical, and nonlinear load, which adversely affects the quality indicators of electricity supply. Typically, this negative impact is reduced by connecting EAFs to high power energy systems or, in most cases, by applying different types of static reactive power compensators. Such approaches require considerable investment in the development of the power system or in the equipment of compensatory installations whose rated capacity is several times higher than the capacity of the furnace transformer.

These approaches aim to reduce the effects of negative impact. It is possible to achieve the greater effect of limiting the negative impact, at smaller investments, by using an alternative approach that aims directly at the source of the negative impact. The approach implementation implies forming an external characteristic of the EAF power supply. The characteristic should be rigid in current in the region of furnace operating modes from operational short circuit to the rated load. In the region of modes from the rated load to idling, this characteristic should be rigid in voltage. Underlying the formation of this characteristic is a resonance converter, which ensures almost a stable value of the arc current under the furnace operating modes.

This study has confirmed the significant benefits of the proposed approach, which proves more effective in improving the quality of electricity in the network. This makes it possible to use EAFs in smaller power systems and ensure the development of the industry at a lower investment

Keywords: reducing the flicker dose, voltage fluctuations, electricity quality, electric arc furnace

Received date 16.11.2020

Accepted date 04.12.2020

Published date 21.12.2020

1. Introduction

Most electrical energy receivers have a range of normal operating modes in the interval from idling to the rated load. Connecting such installations to a power supply network whose voltage is supported almost constant at $U=\text{const}$ ensures their high performance and electromagnetic compatibility with the network.

Electric arc installations, including EAFs, form a different group of electrical loads, which have a range of normal operating modes from operational short circuit to the rated load. For such installations, the power system $I=\text{const}$ is more natural. For the purpose of certain adaptation of such electric receivers to a conventional power supply network at $U=\text{const}$, a certain restriction of currents of operational short circuits to 1.8–2.5 relative units is imposed. Such a technique involving low-power installations resolves to a certain extent the issue of electromagnetic compatibility under conditions of dynamic loading; however, their perfor-

UDC 621.365.2

DOI: 10.15587/1729-4061.2020.219439

USING THE CONSTANT CURRENT – CONSTANT VOLTAGE CONVERTERS TO EFFECTIVELY REDUCE VOLTAGE FLUCTUATIONS IN THE POWER SUPPLY SYSTEMS FOR ELECTRIC ARC FURNACES

V. Turkovskiy

PhD, Associate Professor*

E-mail: volodymyr.h.turkovskiy@lpnu.ua

A. Malinovskiy

Doctor of Technical Sciences, Professor*

E-mail: anton.a.malinovskiy@lpnu.ua

A. Muzychak

PhD, Associate Professor*

E-mail: andriy.z.muzychak@lpnu.ua

O. Turkovskiy

Lead Engineer*

E-mail: tur.oleg.vol@gmail.com

*Department of Electric Power Engineering and Control Systems

Lviv Polytechnic National University
S. Bandery str., 12, Lviv, Ukraine, 79013

Copyright © 2020, V. Turkovskiy, A. Malinovskiy, A. Muzychak, O. Turkovskiy

This is an open access article under the CC BY license

(<http://creativecommons.org/licenses/by/4.0>)

mance indicators and operational characteristics are compromised. In particular, there are increased power losses, complicated control over arc power, the need for deep adjustment of the voltage of the furnace transformer, as well as the increased dynamic forcing on the current-conducting parts.

However, for arc furnaces of high power, this technique does not make it possible to ensure their electromagnetic compatibility, and, therefore, the use of such furnaces requires means to improve the quality indicators of electricity. Note that such means do not affect the dynamics of changes in the furnace currents and the arc power adjusting technique.

It has been proposed to form an external characteristic for EAF power source with the regions $I=\text{const}$ and $U=\text{const}$. The $I=\text{const}$ region is used in the range of operating modes from operational short circuit to the rated load; the $U=\text{const}$ region – for modes from the rated load to idling.

We report the results of studying a conventional furnace power supply scheme (CSC) and a scheme involving the “constant current – constant voltage” converter (CC-CVC).

The comparative analysis of the dynamic modes of these schemes was carried out under the same conditions where the problem was linearly symmetrically stated.

The study results are relevant as they substantiate the possibility of connecting furnaces to lower power systems, thereby reducing the cost of funds for the development of the power system or compensating equipment. Such a proposal positively affects the operational features of a furnace installation itself. Specifically, it reduces power losses in the secondary circuit of the furnace installation, as well as provides for an even loading of phases under operating modes. There is also the possibility of smooth adjustment of arc power in a wide range without switching voltage levels. This could simplify the design of a voltage controller in a furnace transformer, or completely abandon it. The steady current under the modes of loading and operational short circuits leads to a decrease in the dynamic forcing on the equipment of the furnace installation and makes it possible to simplify its elements design.

2. Literature review and problem statement

AC electric arc furnaces represent a special type of load on electricity systems, which is dynamic, asymmetrical, and nonlinear at the same time. Consequently, these furnaces adversely affect the quality of electricity at the nodes of their connection. Paper [1] examined the main factors influencing the short-term dose of the flicker, as well as the conditions under which this dose could exceed the permissible values by 5 or 10 times. The authors also assessed a decrease in the flicker dose by using compensating units. Based on experimental studies, work [2] confirmed exceeding the permissible value of the multiplicity of the amplitude of voltage change by 6.2 times and showed that the probability of exceeding this value was low.

Irregular variable load on arc furnaces is a typical source of interharmonics [3]. The time-variable and nonlinear arc performance generates a spectrum of current with several spectral components, including not only harmonics but interharmonics as well. Since the arc's performance is chaotic, the furnace generates interharmonics at ever-changing chaotic frequencies. According to [4], EAF is a powerful source of a wide range of harmonics and interharmonics; the interharmonics levels could reach 10 % of the current of the main frequency. The spectrum of interharmonics for the furnace with a capacity of 100 tons is in the frequency range of 0.01–2.0 Hz; their energy is about 20 % of all mixed spectrum energy [5]. Study [6] showed the presence of a spectrum of interharmonics at frequencies above 200 Hz, as well as a constant component in the current of the arc whose value is correlated with the rated current of the furnace transformer magnetization. A wide range of higher harmonics was reported in [7]; the study results show the existence of individual harmonics of the furnace current with a value of 12 %, and a constant component of 3 %, of the rated current of the furnace.

Paper [8] gave a characteristic of the arc furnace as a special continuously changing load, which does not have two identical in shape current periods. As a result, the furnaces cause an asymmetric load of phases and generate higher harmonics in the power system network. In order to reduce the uneven loading of phases of arc furnaces, study [9] proposed the criteria for assessing the asymmetry of the electric

circuit of the furnace. Their application yields a more homogeneous assessment of the circuit parameters and makes it possible to improve the balancing of asymmetrical modes.

The results from a large-scale study of the state of electricity quality at the country's metallurgical enterprises [10] established its inconsistency with the requirements of the standard in many cases. It was shown that the generally accepted practice of using compensating systems does not make it possible to resolve the issue of flickering at nodes connecting units to the power system.

An experimental analysis of EAF with a capacity of 100 tons with a 75 MVA furnace transformer has revealed the presence of jumps in the active and reactive power during scrap melting [11]. That caused the fluctuations and asymmetry of voltage in the grid. It was also established that the furnace possessed a low power factor of 0.7–0.8.

Based on the results of measuring electricity quality indicators and model tests, the authors of work [12] confirmed that the main negative consequence of arc furnace operation is voltage fluctuations. Proper quality of electricity in the network could be ensured when the ratio of the power of the short circuit of an energy system to the short circuit power of the loaded furnace is at the level of 120–130. The issue of voltage distortion in the network with an electric arc furnace could be resolved by using filters of higher harmonics configured to the corresponding frequencies [13] taking into consideration the frequency characteristics of the power system at a joint connection point.

Statistical approaches are employed to analyze the quality of electricity in the power supply network of the arc furnace. Paper [14] reports the results of an analysis of the higher harmonics, interharmonics, asymmetry, and flicker, described as the values of a cumulative probability function (CPF) that are not exceeded at a probability of 99 %, 95 %, 90 %, and 50 %.

Reducing voltage fluctuations could be achieved with different types of static reactive power compensators. According to experimental data from [15], the value of the short-term dose of the flicker decreases from 4–6 % to 2.5–3 %. In the absence of compensating tools, the quality of electricity, according to experimental research in [16, 17], does not meet the requirements. Exceeding the permissible value of the flicker by 10 times, as well as the unacceptable values of a current distortion coefficient, may occur at insufficient power system capacity [18].

According to [19], the use of a static synchronous compensator (STATCOM) could reduce the short-term dose of the flicker by 5 times if the network impedance and its changes are properly accounted for. A comparison of the different STATCOM execution options given in [20] showed that a 12-pulse STATCOM with an RLC filter could reduce the flickering voltage caused by the nonlinear loads of electric arc furnaces. A comparison of different variants of STATCOM implementation was also performed in work [21]. According to the authors, the 6-pulse STATCOM reduces the voltage flicker by 50 %; the 12-pulse one could eliminate voltage flickering and ensure a minimum distortion coefficient.

The main negative effects on the power system exerted by a non-stationary load of the furnace are associated with a change in the voltage module [22] and are assessed by the corresponding indicator – the dose of the flicker. The extent of the impact depends on the power of the short circuit of the power system at the joint point of connection [23]. The

issue of flicker occurrence, its subjective perception, possible consequences, and ways of reducing it, are considered in detail in [24]. The focus of the cited work is the use of different variants of compensating devices. A comparative analysis of reactive power compensation technologies, namely using a synchronous condenser, a static variable voltage compensator (SVC), and a static synchronous compensator, as well as the assessment of their application scope, was performed in [25]. A wide overview of conventional and modern electricity quality improvement devices is provided in [26]. It is noted that the equipment for improving the quality of electricity of the next generation is mainly multifunctional, which ensures its improved efficiency and reliability. Paper [27] compares the different energy quality assurance devices at power units of the compensatory type, in particular, a distribution static compensator (DSTATCOM), a dynamic voltage restorer (DVR), and gives the characteristics of their efficiency and application scope.

The use of reactive power compensators for EAF requires the installation of additional equipment whose power is commensurate with the power of a furnace transformer. According to [28, 29], the specific cost of STATCOM equipment is USD 300 per kVA. Thus, for an arc furnace with a furnace transformer of 70 MVA, the estimated value of the required investments in compensating tools would amount to USD 21 million.

Paper [30] describes a static reactive power compensator (SVC) for an arc furnace whose furnace transformer's capacity is 75 MVA. This compensator was designed to provide a short-term dose of the flicker less than 1.5 at the point of joint connection on the 220 kV buses. The total rated capacity of SVC equipment elements is 270 MVA, which exceeds the capacity of the furnace transformer by 3.6 times.

Work [31] shows that using the STATCOM compensator makes it possible to improve the quality of electricity in the network, in particular, it makes it possible to reduce a voltage distortion coefficient in the network. The data from [32] confirms a decrease in voltage fluctuations when applying STATCOM.

Paper [33] describes the modernization of a metallurgical enterprise, due to the increase in the capacity of arc furnaces. To reduce voltage fluctuations, a 70 Mvar SVC was installed, which allowed for a 1.9-fold reduction in short-term flicker dose.

The use of a static reactive power compensator executed with the simultaneous application of capacitor switch units (TSC) and a reactor adjusted by thyristors (TSR) in one installation is considered in [34]. This ensures more flexibility of regulation; the authors also imply the use of passive filters of higher harmonics.

Work [35] examines the use of a static STATCOM compensator with a capacitive DC power storage unit. This makes it possible to compensate not only for the reactive but also active power. The use of a static synchronous compensator with an improved control system could significantly reduce aperiodic fluctuations in the power system and improve furnace performance [36].

Applying a consistently enabled controlled reactor exerts a positive effect on network voltage fluctuations [37]. The multiplicity of a short-term flicker dose decrease may exceed 5. Since adjusting the voltage of the furnace transformer affects the stability of arc burning, the authors of [38] proposed to carry out coordinated adjustment of the parameters of the sequential reactor, which ensures optimal

furnace operation. The results of studying the modes of arc steel-melting furnace with the reactor, consistently enabled, and passive filters on the side of 30 kV are given in [39]. It was experimentally proven that the quality of electricity meets the requirements but, in some periods of operation, the short-term dose of the flicker may slightly exceed the normative value.

A differentiated approach to improving the quality of electricity is also proposed in [40] only for consumers that are sensitive to voltage fluctuations.

Our review reveals that voltage fluctuations are the main parameter of negative impact exerted by arc steel-melting furnaces on the network. A quantitative characteristic most often used for these fluctuations is a short-term dose of the flicker, which takes into consideration not only the module but also the frequency of changes in network voltage.

The peculiarity of the use of static compensators of reactive power is that their action is directed at eliminating the negative effects of the dynamic operation of furnaces in the network. More effective may prove to be measures aimed directly at the source of the negative impact, that is, at reducing the level of generating a negative factor [41, 42]. This could be implemented on the basis of an inductive-capacitive converter with an external characteristic of the $U=\text{const}$ type [43, 44], which has a section of the $U=\text{const}$ characteristics. As a result, such a converter would maintain a stable arc current value in the region of modes from the short circuit to the rated load. In the range of modes from the rated load to idling, the stable value would be accepted by a power supply voltage. As a result, the consumption of the reactive power by a furnace under operating modes would be unchanged and the component of voltage fluctuations in the network, due to changes in the reactive power, would be close to zero.

When powering powerful consumers, the component of voltage losses from the active load is an order of magnitude less than the component of losses caused by the reactive load. This makes it possible to expect a reduction in the loss of voltage in the network, and, accordingly, its fluctuations, by about 10 times. In addition, the use of CC-CVC makes it possible to implement modes with almost zero consumption of reactive power from the network [45].

Additional equipment is required for CC-CVC. The estimation of its rated power is given in [46].

3. The aim and objectives of the study

The aim of this study is to justify the possibility of effective reduction of voltage fluctuations in the power supply network of arc steelmaking furnaces using the “constant current – constant voltage” converter.

To accomplish the aim, the following task have been set:

- to determine the short-term dose of the flicker at the joint point of connection for a conventional furnace power scheme and for the CC-CVC-based circuit, as well as the corresponding comparative quantitative indicators.

4. Mathematical and MATLAB Simulink models of the compared schemes

The quantitative indicators of voltage fluctuations were derived using a digital mathematical model for the linear

and symmetrical load under the same conditions, that is, for one type of furnace and the same dynamics of load power change.

The conventional power scheme of arc steel-melting AC furnaces (CSS) consists of an FT furnace transformer and a short SC network that connects the FT's secondary winding to an electric arc furnace EAF. The FT's primary winding is connected to the PCC joint point of the PS power system network bus (Fig. 1). To enable voltage adjustment of the secondary winding and arc power, the FT is equipped with a branching switch on its primary winding. In addition, in order to limit the currents of operational short circuits, the scheme includes a reactor enabled on the side of the primary winding.

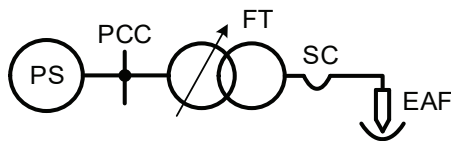

Fig. 1. Conventional scheme to power an electric arc furnace

The structural diagram of powering an arc furnace using CC-CVC is shown in Fig. 2. The arc furnace EAF receives power through a short SC network from the FT's secondary furnace transformer windings. On the BH side, inductive IE and capacitive CE elements are enabled, connected, accordingly, to the primary windings of the transformer and connected to PCC. The choice of the reduced resistances of the inductive and capacitive elements based on the resonance condition provides for a stable value of the arc current in the normal range of changes in its length (from operational short circuit to the rated load). As a result, the reactive power under variable load conditions would also accept a stable value, which would ensure a significant reduction in voltage fluctuations in the network. Under abnormal modes, from the rated load to idling, the installation maintains a stable arc voltage value using molding elements (not shown in the structural diagram).

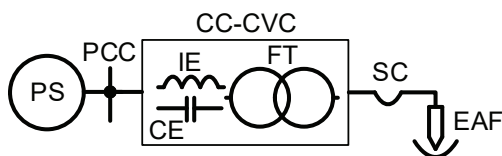

Fig. 2. Structural diagram of powering an arc furnace using CC-CVC

The following results were established for an arc steel melting furnace with a capacity of 160 tons, equipped with a 140 MVA furnace transformer with voltages of 35/1.3 kV. Other parameters of the electric equipment of the furnace: the voltage of the short circuit of the transformer – 8%; the relative active losses of the transformer's short circuit experiment – 0.8%. The inductive and active resistance of the short network is, respectively, 4.75 and 0.68 mOhm. Taking into consideration the inductiveness of the high-voltage reactor, the total reactive resistance of the circle is 6.23 mOhm, and the multiplicity of the current of the operational short circuit is 1.92. The equivalent arc resistance at the rated load is 9.62 mOhm.

To calculate the modes of the above schemes, a mathematical model has been built using a method of contour

coordinates (the currents of branches and flux couplings of the transformer and reactor windings). Electromagnetic processes in the given scheme of the furnace power supply under this method are described by the following system of equations:

$$GMG_t \frac{d\vec{i}_k}{dt} + GRG_t \vec{i}_k + G(\vec{u}_n + \vec{u}_c) = G\vec{e};$$

$$C \frac{d\vec{u}_c}{dt} - G_t \vec{i}_k = 0, \quad (1)$$

where \vec{i}_k is the vector-column of contour coordinates of the scheme branches; \vec{u}_n , \vec{u}_c , \vec{e} are the vectors-columns, respectively, of the voltage of the nonlinear elements, the voltages of capacitive elements and the EMF of electrical circle branches; G , G_t is the second matrix of incidents of the circuit graph, combined for the branches of electrical and magnetic circles, and its transposed matrix; M , R are, respectively, the matrices of natural and mutual inductions and active resistances of the scheme's branches, combined for electric and magnetic circles; C is the capacitance matrix of the scheme's branches.

For a conventional arc steel furnace power scheme, CSS, the equation system (1) has an order of 8; for CC-CVC, 17.

We calculated and analyzed the electromagnetic processes described by the equation system (1) using the MATLAB Simulink software environment.

The MATLAB Simulink block diagram of the model shown in Fig. 3 includes the following components: unit 3 (Gt matrix) – the unit to form the second matrix of the scheme's graph incidents; unit 2 (Parameters) – input formation unit, calculation conditions (dynamic, asymmetrical, stochastic modes, etc.); units 4–6 (the components of M, R, C matrices); unit 7 (E vector) – a unit of components of the vector of electric motive forces; unit 12 – setting the initial conditions. In addition, the MATLAB Simulink scheme of the model includes the units of mathematical operations over matrixes (units 9–11), inverting (unit 8), as well as numerical integration (unit 13). The Parameters unit also sets the characteristics of nonlinear circuit elements, including the magnetic system of the transformer and reactor. In unit 1 (Cassie model), a linear or nonlinear arc model (Cassie model or other) is specified. The Results unit is designed to process the results, that is, to calculate the active and rms values, symmetrical and harmonic components of the mode indications, as well as their probable characteristics.

During the calculations, the relative short circuit power capacity of the energy system S_{sc} was taken in the range of 8–100 relative units of the rated power of the furnace transformer. The ratio of reactive resistance of the system to the active resistance was 20.

The analysis of experimental diagrams of the current of arc steel-melting furnaces of different capacity [10–18] reveals significant stochastic dynamics in the CSS arc current change, especially during the initial melting period. These dynamics possess a certain quasi-periodicity; the boundary modes, idling and operational short circuit, under which there is no release of energy in the furnace, occur quite infrequently, especially three-phase. In our work, the analysis of voltage fluctuations is carried out for a set of working dynamic modes under which there is an energy release by the arc.

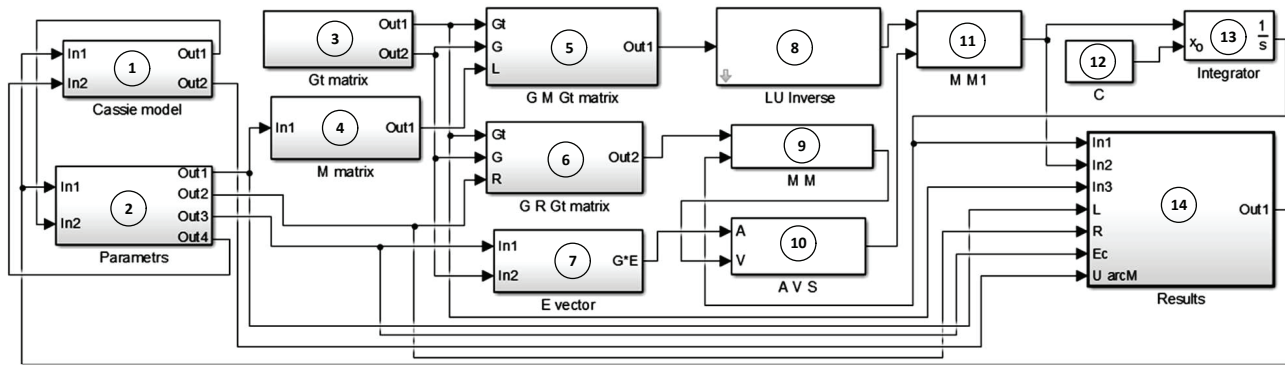

Fig. 3. MATLAB Simulink block diagram of the arc furnace power model

For a comparative analysis of the indicators of different variants of the furnace power supply scheme, it is accepted that the load is linear and symmetrical. Under these conditions, the replacement circuit of the furnace electric circuit is composed of consistently enabled equivalent active arc resistance and the active and reactive resistances of the circle, including resistances of the secondary current drive and the secondary windings of the furnace transformer. Under a dynamic load, arc resistance is a function of time; it changes as follows:

$$R_{arc}(t) = R_{arcm} (1 + KR_v \sin 2\pi f_v t), \quad (2)$$

where $R_{arc}(t)$ is the equivalent dynamic arc resistance; R_{arcm} is the average value of the equivalent arc resistance; KR_v is the relative amplitude of change in the arc resistance; f_v is the frequency of change in the arc resistance.

5. Characteristics of the dynamic modes of the compared furnace power supply schemes

5.1. Voltage fluctuations in the CSS circuit

The results obtained when using a Simulink model for the CSS scheme under dynamic load conditions are shown in Fig. 4. The calculation was performed for the following initial data: load change frequency, 1 Hz; the relative power of short circuit of the power system at the point of connection to the furnace, 100 relative units; the average value of equivalent arc resistance, 26.4 mOhm; the relative amplitude of arc resistance change, 0.72. The accepted value of the relative amplitude of arc resistance change makes it possible to derive a range of change in the equivalent load resistance, close to the limit, which is possible at the initial stage of melting the charge.

In the diagrams in Fig. 4, the following designations are used: U_{arc} , I_{arc} , P_{arc} , R_{arc} are, respectively, the voltage, current, power, and arc resistance; Q_{sys} is the reactive power of the system; dU_{sys} is the voltage deviation in the network.

All mode settings in Fig. 4 are given in relative units. The following basic values were accepted: for arc resistance, its average value is 26.4 mOhm; for arc current, the rated current of furnace transformer is 62.25 kA; for arc voltage, the rated phase voltage of the secondary winding in a furnace transformer is 750 V;

for active arc power, the rated full power of a furnace transformer is 140 MVA; for power supply losses in the network, a voltage of 100 V.

The diagram shows that, according to the arc resistance change, other mode settings change periodically. The extreme arc power values are 117 and 35.4 MW. Its change spread is 81.6 MW, which is 72 % of the rated active furnace capacity. This value is close to limiting regular changes in furnace power. The reactive power of the furnace varies from 4.8 to 98.4 Mvar. The maximum speed of its growth has been determined, which is 562 Mvar/s. The arc current varies from 72.55 to 16.12 kA, meaning the change range is slightly smaller than the rated current of the furnace. Arc voltage takes a value from 731 to 537 V; its change range is 25.8 % of the rated voltage of the secondary winding of the furnace transformer. Changing the furnace mode settings causes voltage fluctuations in the power supply network, whose change range is 146.1 V, that is, 0.72 % of the rated phase voltage of the network. The admissibility of such changes could be determined on the basis of the standard set in [47].

To assess the extent of the negative impact on the power supply, the measure of this impact applied is a dose of the flicker. Under a standard dependence of the dose of the short-term flicker P_{st} on frequency [47], the permissible value of changes in the original voltage of the sine shape with a frequency of 1 Hz is 1.432 %. Thus, the dose of the short-term flicker would equal $0.72:1.432=0.5$, that is, it does not exceed the permissible value equal to 1.

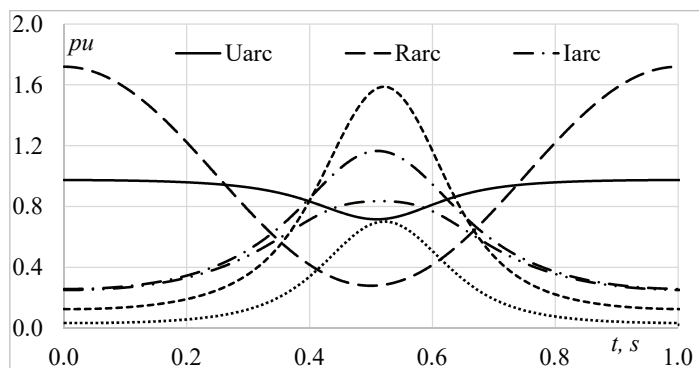

Fig. 4. Time diagrams of CSS mode parameters

The rate of increase or decrease in the reactive power for a stable amplitude of changes would depend on the

frequency of change in the load f_v . According to the data reported in [48] and based on experimental observations, the rate of growth of the reactive power of arc steel-melting furnaces is estimated at 500 Mvar/s. Given the growth of the single capacity of modern furnaces, it can be assumed that this value may be slightly higher. Based on this, the upper limit of the load change frequency f_v in our study was limited to 4 Hz, at which the rate of growth of the reactive power exceeds 1,000 Mvar/s.

The effect of the CSS load change frequency on a flicker short-term dose value at a common point for different capacities of the power systems is illustrated in Fig. 5. The plots were built for the frequencies of change f_v from 1 to 4 Hz and the range of the relative power of short circuit in a power system from 8 to 100 relative units.

The data above show that in the range of changes in the relative power of the short circuit in an energy system S_{sc} from 100 to 40 relative units, a dose of the short-term flicker P_{st} increases almost in line with linear dependence. For the energy system power values from 40 to 20 relative units, the P_{st} growth rate becomes greater, and in the range of 20–8 relative units – the rate of growth in the values of a flicker dose reaches the highest values.

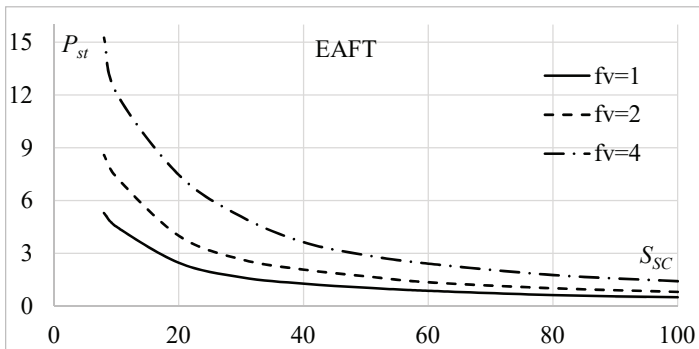

Fig. 5. Dependences of the CSS flicker short-term dose on the relative capacity of a power system

The frequency of load change significantly affects the value of the flicker dose; the increase in frequency causes it to grow. At the energy system power $S_{sc}=100$ relative units, the flicker dose for frequencies 1, 2, and 4 Hz is, respectively, 0.5, 0.8, and 1.42; for $S_{sc}=8$ relative units, respectively, 5.3, 8.6, and 15.3.

5.2. Voltage fluctuations in the CC-CVC scheme

We calculated the short-term dose of the flicker for a furnace with the CC-CVC converter at changes in the equivalent load resistance corresponding to equation (2). The R_{arc} and KR_v values were selected to ensure that the active arc power change range is set. The base value is $R_{arc}=6.13$ mOhm; the relative load change amplitude is $KR_v=0.65$. The maximum value of the arc power change range was 84 MW, which is almost the same as in the CSS scheme. The deviation of arc power change range for the compared furnace power schemes at variable variation did not exceed 0.5 %.

The time diagrams of change in the same mode settings as in the previous scheme, acquired for a dynamic load from the Simulink model, are shown in Fig. 6. The plots were built in the same system of relative units, which was used to analyze CSS results, except for $R_{arc}=6.13$ mOhm.

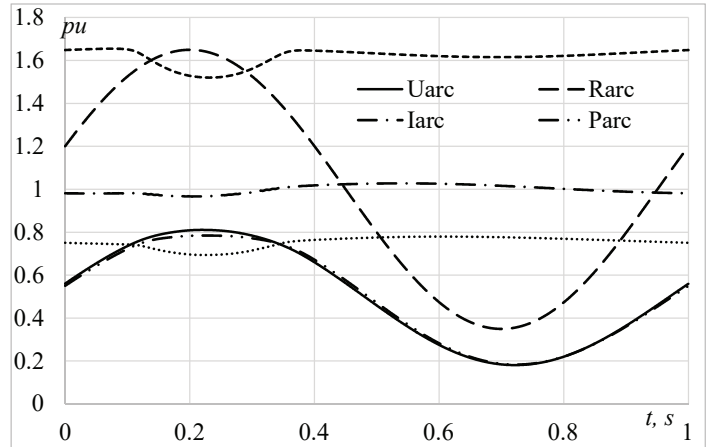

Fig. 6. Time diagrams of mode parameters for a furnace with CC-CVC

The diagrams show that a change in the active arc resistance R_{arc} causes a corresponding change in the voltage U_{arc} and in the arc power P_{arc} . However, the current of the arc I_{arc} , due to the use of CC-CVC, varies in a narrow range from 63.4 to 60.2 kA, that is, it is almost stable. Consequently, the reactive power Q_{sys} , consumed from the network, also accepts a nearly stable value as it varies from 109.1 to 97.2 Mvar.

The constructed dependences of the flicker short-term dose on the energy system power for CC-CVC are shown in Fig. 7.

As one can see, for the CC-CVC scheme, the relative power of the energy system and the frequency of load change are the parameters that significantly affect the value of a flicker dose.

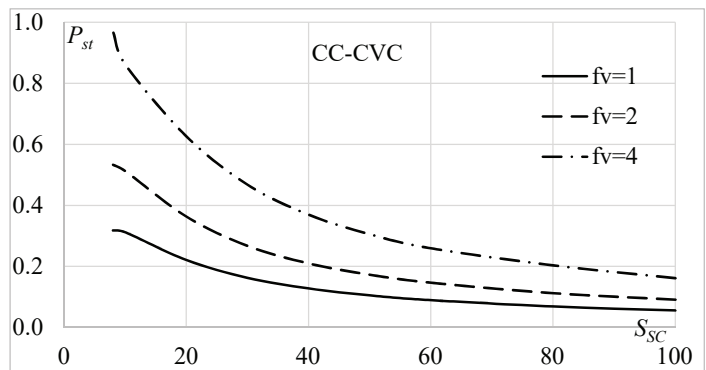

Fig. 7. Dependences of a flicker short-term dose for CC-CVC on the relative capacity of a power system

Based on the results obtained, we built in Fig. 8 the dependences of the flicker decrease multiplicity KP_{st} as the ratio of a flicker dose in the network according to the conventional CSS arc furnace power scheme to

the value of the same dose in the power circuit using CC-CVC.

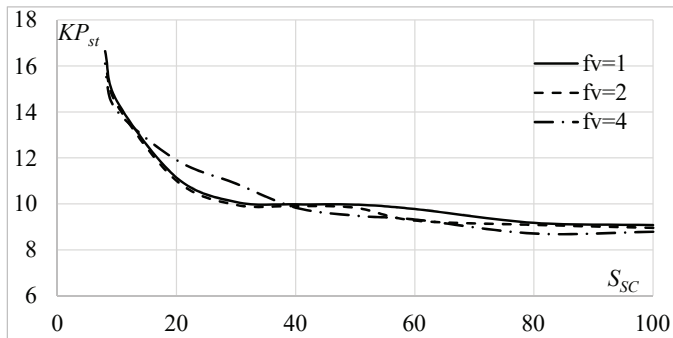

Fig. 8. Dependences of the multiplicity of a flicker dose decrease on the relative power of an energy system

The results in Fig. 8 show that in the range of change in the relative power of the short circuit of the energy system from 100 to 30 relative units, the growth rate KP_{st} is not great. For less powerful energy systems, whose S_{sc} values are less than 20, these rates would increase dramatically.

6. Discussion of the results of studying voltage fluctuations in networks for the compared power supply schemes

AC electric arc furnaces under conventional schemes of their power supply negatively affect all the main indicators of electricity quality in the network, the principal among them being voltage fluctuations. Our study results showed that during the initial melting period in the furnace, when the spread of changes in the arc active power is close to a maximum value (Fig. 5), the permissible values of the flicker dose could only occur for large power energy systems. Such systems should have a short-circuit power at a load connection unit that is 80–100 times the power of the furnace transformer.

The conventional approach to reducing voltage fluctuations in the power supply networks for such furnaces mainly involves the use of different execution variants of static compensators of reactive power. This reduces the short-term dose of the flicker by 1.5–3 times; when using STATCOM – to reach 6.

The application of compensating devices makes it possible to improve the quality of electric energy, but not always to meet the requirements of standards. According to a thorough study reported in [10], even though almost all enterprises in the industry are equipped with modern static compensators of reactive power, the values of short-term and long-term flicker at most enterprises exceed the permissible limits. Even bigger problems emerge at the energy system nodes that power several furnaces.

The proposed alternative approach is based on taking into consideration the features of arc steel-melting furnaces, which are characterized by a range of normal operating modes from operational short circuit to the rated load. For such installations, the $I=\text{const}$ power system is more natural. Applying such a system changes approaches to improving electricity quality in the net-

works that power electric arc furnaces. The proposed measures are now directed not to eliminate the negative effects of furnaces but directly to their source in order to reduce the level of generating a negative factor.

We have proposed using, to power an arc furnace, an AC converter with an external characteristic of the “constant current – constant voltage” (CC-CVC) type. Such a converter ensures under operating modes from operational short circuit to the rated load an almost stable value of the arc current. In the range from the rated load to idling, a stable power supply voltage value is maintained.

Stabilization of arc current under operating modes provides for an almost stable consumption of reactive power from the grid. Owing to this, the component of voltage losses in the network is dramatically reduced, due to changes in the consumption of reactive power.

This is confirmed by the diagrams in Fig. 7 showing that the use of CC-CVC ensures the standard-approved values of the flicker dose over the entire considered region of an energy system’s power values and a load change frequency. In particular, for the relative power of an energy system equal to 8 relative units and at the frequency of load change of 4 Hz, the short-term flicker dose is 0.97. When employing a conventional power scheme, this dose equals 15.25.

The effectiveness of using CC-CVC is illustrated by the diagrams shown in Fig. 8. The multiplicity of a flicker dose decrease due to the application of CC-CVC is within 9–10 for the relative power range of the short circuit of an energy system from 100 to 30 relative units. For less powerful energy systems whose S_{sc} values are from 20 to 8 relative units, this multiplicity is higher, and increases to 11–16. The efficiency of using CC-CVC in smaller energy systems is greater. Our data support the assumption about the possibility of significantly reducing fluctuations in the power supply network that powers arc steel-melting furnaces by changing the system of their power supply.

The reported study results were obtained under a linear symmetrical load with changes in the power characteristic of the initial melting period. The frequency of load change of 4 Hz was limited to the rate of growth of the active power of the furnace at the level of 1,000 MW/s.

Further research is planned regarding the asymmetric dynamic load, taking into consideration the nonlinearity of the volt-ampere characteristics of the arc.

The application of CC-CVC for arc furnaces has other positive aspects. In particular, it helps achieve a decrease in the power losses in the secondary circuit of the furnace installation, since, at the same average arc current values in the compared circuits, the rms would be smaller for the CC-CVC scheme. The difference in the values of these currents depends on the melting period and is within 10–25%.

Maintaining a stable value of the arc current makes it possible to smoothly and widely change the furnace capacity by changing only one parameter – the length of the arc. This allows us to argue about simplifying the voltage controller of a furnace transformer, or abandoning, under certain conditions, its use. In this case, the typical power of the primary winding of the transformer could be decreased while its dimensions – reduced.

In addition, limiting the current of the secondary circuit of the furnace at the level of the rated value predetermines a decrease in the dynamic forcing on the current-conductive elements, which could simplify their design.

7. Conclusions

1. The results of our study of the dynamic modes of an AC electric arc furnace involving the “constant current –

constant voltage” converter have shown that its application ensures that the multiplicity of reducing the short-term dose of the flicker at the nodes of an energy system with the relative short circuit power in the range of 100 – 30 relative units is 9–10. For energy systems whose relative power values are from 20 to 8 relative units, this multiplicity increases to 11–16. These indicators confirm the effectiveness of using the “constant current – constant voltage” converters in order to improve the quality of electricity in the power supply networks of arc steelmaking furnaces.

References

1. IEEE Std 1453-2015 - IEEE Recommended Practice for the Analysis of Fluctuating Installations on Power Systems. doi: <https://doi.org/10.1109/ieeestd.2015.7317469>
2. Ryzhnev, Yu. L., Mineev, R. V., Miheev, A. P., Smelyanskiy, M. Ya. (1975). *Vliyanie dugovyh elektropechey na sistemy elektrosnabzheniya*. Moscow: Energiya, 185.
3. Testa, A., Akram, M. F., Burch, R., Carpinelli, G., Chang, G., Dinavahi, V. et. al. (2007). Interharmonics: Theory and Modeling. *IEEE Transactions on Power Delivery*, 22 (4), 2335–2348. doi: <https://doi.org/10.1109/tpwrd.2007.905505>
4. Zhezhelenko, I. V., Shidlovskiy, A. K., Pivnyak, G. G., Saenko, Yu. L., Noyberger, N. A. (2012). *Elektromagnitnaya sovместimost' potrebiteley*. Moscow: Mashinostroenie, 351.
5. Zhezhelenko, I. V., Saenko, Yu. L., Baranenko, T. K. (2002). Spektral'niy analiz toka nagruzki istochnikov intergarmonik v promyshlennykh elektricheskikh setyah. *Visnyk Pryazovskoho Derzhavnogo tekhnichnogo universytetu*, 12, 194–201.
6. Yusoff, M. R., Jopri, M. H., Abdullah, A. R., Sutikno, T., Manap, M., Hussin, A. S. (2017). An Analysis of Harmonic and Interharmonic Contribution of Electric Arc Furnace by Using Periodogram. *International Journal of Electrical and Computer Engineering (IJECE)*, 7 (6), 3753. doi: <https://doi.org/10.11591/ijece.v7i6.pp3753-3760>
7. Sarma, P. M., Jayaram Kumar, S. V. (2013). Electric Arc Furnace Flicker Mitigation in a Steel Plant Using a Statcom. *International Journal of Engineering Science and Innovative Technology (IJESIT)*, 2 (1). 227–231. Available at: http://www.ijesit.com/Volume%202/Issue%201/IJESIT201301_33.pdf
8. Howroyd, D. C. (1979). Distortion and Unbalance From Abnormal Loads on a Power System. *IFAC Proceedings Volumes*, 12 (5), 233–240. doi: [https://doi.org/10.1016/s1474-6670\(17\)65310-2](https://doi.org/10.1016/s1474-6670(17)65310-2)
9. Białek, J., Wąsowski, A. (2005). Advantages of changing 3-phase ARC furnaces asymmetry estimation criteria in international and European standards. *Electrical Power Quality and Utilisation*, 11 (1), 93–96.
10. Salor, O., Gultekin, B., Buhan, S., Boyrazoglu, B., Inan, T., Atalik, T. et. al. (2007). Electrical Power Quality of Iron and Steel Industry in Turkey. 2007 IEEE Industry Applications Annual Meeting. doi: <https://doi.org/10.1109/07ias.2007.67>
11. Toma, A. I., Popa, G. N., Iagar, A., Deaconu, S. I. (2010). Experimental analysis of electric parameters of a 100 t UHP electric arc furnace. 2010 IEEE International Conference on Industrial Technology. doi: <https://doi.org/10.1109/icit.2010.5472563>
12. Łukasik, Z., Olczykowski, Z. (2020). Estimating the Impact of Arc Furnaces on the Quality of Power in Supply Systems. *Energies*, 13 (6), 1462. doi: <https://doi.org/10.3390/en13061462>
13. Khalik, H., Aziz, M. M. A., Farouk, E. (2011). Improvement of Power System Distribution Quality Due to Using Dc-Converter Loads and Electric Arc Furnaces. *New York Science Journal*, 4 (12), 10–19.
14. Mayordomo, J. G., Prieto, E., Hernandez, A., Beites, L. F. (2000). Arc furnace characterization from an off-line analysis of measurements. Ninth International Conference on Harmonics and Quality of Power. Proceedings (Cat. No.00EX441). doi: <https://doi.org/10.1109/ichqp.2000.896877>
15. Donsión, M. P., Oliveira, F. (2007). AC arc furnaces flicker measurement with and without a SVC system connected. *Renewable Energy and Power Quality Journal*, 1 (05), 785–788. doi: <https://doi.org/10.24084/repqj05.383>
16. Issouribehere, P. E., Issouribehere, F., Barbera, G. A. (2005). Power quality measurements and operating characteristics of electric arc furnaces. IEEE Power Engineering Society General Meeting, 2005. doi: <https://doi.org/10.1109/pes.2005.1489388>
17. Lu, C.-W., Huang, S.-J., Huang, C.-L. (2000). Flicker characteristic estimation of an AC electric arc furnace. *Electric Power Systems Research*, 54 (2), 121–130. doi: [https://doi.org/10.1016/s0378-7796\(99\)00080-2](https://doi.org/10.1016/s0378-7796(99)00080-2)
18. Nikoloski, L., Rafajlovski, G. (2000). Power quality aspects of arc steel melting furnace. A case study. 2000 10th Mediterranean Electrotechnical Conference. Information Technology and Electrotechnology for the Mediterranean Countries. Proceedings. MeleCon 2000 (Cat. No.00CH37099). doi: <https://doi.org/10.1109/melcon.2000.879681>
19. Larsson, T., Poumarede, C. (1999). STATCOM, an efficient means for flicker mitigation. IEEE Power Engineering Society. 1999 Winter Meeting (Cat. No.99CH36233). doi: <https://doi.org/10.1109/pesw.1999.747380>

20. Mustafa, D., Sridhar, P., Bhaskar, V., Aditya, P. (2017). Compensation of Voltage Flicker by Using Statcom and Facts Devices. *International Journal of Innovative Research in Electrical, Electronics, Instrumentation and Control Engineering*, 5 (8), 122–130. Available at: <https://www.ijireeice.com/upload/2017/august-17/IJIREEICE%2020.pdf>
21. Tadivaka, T., Srikanth, M., Muni, T. V. (2014). THD reduction and voltage flicker mitigation in power system base on STATCOM. *International Conference on Information Communication and Embedded Systems (ICICES2014)*. doi: <https://doi.org/10.1109/icices.2014.7034161>
22. Vorganti, D., Sriram, C. (2014). Implementation of SPWM Technique in D-STATCOM for Voltage Sag and Swell. *International Electrical Engineering Journal (IEEJ)*, 5 (12), 1649–1654.
23. Couvreur, M. (2001). The concept of short-circuit power and the assessment of the flicker emission level. *16th International Conference and Exhibition on Electricity Distribution (CIRED 2001)*. doi: <https://doi.org/10.1049/cp:20010765>
24. DeDad, J. (2007). Flicker: Causes, Symptoms, and Cures. *Electrical Construction and Maintenance*. Available at: <https://www.researchgate.net/publication/298602970>
25. Igbinoia, F. O., Fandi, G., Svec, J., Muller, Z., Tlustý, J. (2015). Comparative review of reactive power compensation technologies. *2015 16th International Scientific Conference on Electric Power Engineering (EPE)*. doi: <https://doi.org/10.1109/epe.2015.7161066>
26. Naderi, Y., Hosseini, S. H., Ghassem Zadeh, S., Mohammadi-Ivatloo, B., Vasquez, J. C., Guerrero, J. M. (2018). An overview of power quality enhancement techniques applied to distributed generation in electrical distribution networks. *Renewable and Sustainable Energy Reviews*, 93, 201–214. doi: <https://doi.org/10.1016/j.rser.2018.05.013>
27. Jirange, S. N., Kinge, A. P. (2017). A Review on Power Quality Compensation Devices. *International Journal of Scientific Development and Research (IJS DR)*, 2 (9), 29–36.
28. Shahgholian, G., Golibagh, M. (2012). Compensation for Power Quality Improvement in Electric Arc Furnace with Considering Economic Index. *Majlesi Journal of Electrical Engineering*, 6 (1), 62–69.
29. Chandra, B., Visali, N. (2013). Optimal Placement of SVC with Cost Effective Function Using Particle Swarm Optimization. *International Journal of Emerging Trends in Engineering Research*, 1 (2), 41–45. Available at: <http://warse.org/pdfs/2013/ijeter02122013.pdf>
30. Grunbaum, R., Dosi, D., Rizzani, L. (2005). SVC for maintaining of power quality in the feeding grid in conjunction with an electric arc furnace in a steel plant. *18th International Conference and Exhibition on Electricity Distribution (CIRED 2005)*. doi: <https://doi.org/10.1049/cp:20051037>
31. Gajjar, K., Patel, P., Rawal, D. (2017). Modelling and Simulation of STATCOM Device for Voltage Flickering Mitigation. *National Conference on Emerging Trends, Challenges & Opportunities in Power Sector*. Published by IJSRD, 72–80. Available at: <https://www.academia.edu/31706912>
32. VeeraRaghava, J. H. V., Sekhar, K. C. (2012). Effective Mitigation of Voltage Flicker in Power System using 12-Pulse Converter based Statcom. *International Journal of Computer Applications*, 44 (18), 22–26. doi: <https://doi.org/10.5120/6363-8458>
33. Hackl, G., Renner, H., Krasnitzer, M., Hofbauer, C. (2012). Electric Arc Furnace with Static Var Compensator – Planning and Operational Experience. *10th EEC European Electric Steelmaking Conference*. Graz, 457–464.
34. Liberado, E. V., Souza, W. A., Pomilio, J. A., Paredes, H. K. M., Marafao, F. P. (2013). Design of static VAR compensator using a general reactive energy definition. *International School on Nonsinusoidal Currents and Compensation 2013 (ISNCC 2013)*. doi: <https://doi.org/10.1109/isncc.2013.6604455>
35. Yanushkevich, A., Müller, Z., Švec, J., Tlustý, J., Valouch, V. (2014). Power Quality Enhancement using STATCOM with Energy Storage. *Renewable Energy and Power Quality Journal*, 349–354. doi: <https://doi.org/10.24084/repq12.336>
36. Yazdani, A., Crow, M. L., Guo, J. (2009). An Improved Nonlinear STATCOM Control for Electric Arc Furnace Voltage Flicker Mitigation. *IEEE Transactions on Power Delivery*, 24 (4), 2284–2290. doi: <https://doi.org/10.1109/tpwr.2009.2027508>
37. Pires, I. A., Cardoso, M. M. G., Cardoso Filho, B. J. (2016). An Active Series Reactor for an Electric Arc Furnace: A Flexible Alternative for Power-Flow Control. *IEEE Industry Applications Magazine*, 22 (5), 53–62. doi: <https://doi.org/10.1109/mias.2015.2459093>
38. Samet, H., Ghanbari, T., Ghaisari, J. (2014). Maximizing the transferred power to electric arc furnace for having maximum production. *Energy*, 72, 752–759. doi: <https://doi.org/10.1016/j.energy.2014.05.105>
39. Gała, M. (2019). Praca pieca łukowego AC w systemie elektroenergetycznym. *PRZEGLĄD ELEKTROTECHNICZNY*, 1 (12), 248–253. doi: <https://doi.org/10.15199/48.2019.12.56>
40. Elnady, A., Salama, M. M. A. (2007). Mitigation of the voltage fluctuations using an efficient disturbance extraction technique. *Electric Power Systems Research*, 77 (3-4), 266–275. doi: <https://doi.org/10.1016/j.epsr.2006.03.011>
41. Malinovskyi, A., Turkovskiy, V., Muzychak, A., Turkovskiy, Y. (2018). The Efficient Power Supply Scheme of Alternating Current Electric Arc Furnaces. *2018 IEEE 3rd International Conference on Intelligent Energy and Power Systems (IEPS)*. doi: <https://doi.org/10.1109/ieps.2018.8559585>

42. Turkovskiy, V., Malinovskiy, A., Muzychak, A., Turkovskiy, O. (2019). The Simulation and Analysis of the Probabilistic Characteristics of Schemes for Power Supply of Electric Arc Furnaces in Non-symmetric Modes. 2019 IEEE 20th International Conference on Computational Problems of Electrical Engineering (CPEE). doi: <https://doi.org/10.1109/cpee47179.2019.8949144>
43. Volkov, I. V., Gubarevich, V. N., Isakov, V. N., Kaban, V. P. (1981). Printsipy postroeniya i optimizatsiya shem induktivno-emkostnyh preobrazovateley. Kyiv: Naukova dumka, 173.
44. Volkov, I. V., Styazhkin, V. P., Podol'niy, S. V. (2009). Sistemy stabilizirovannogo toka dlya avtomatizirovannyh elektroprivodov. Pratsi Instytutu elektrodynamiky Natsionalnoi akademiyi nauk Ukrainy, 23, 64–71.
45. Malinovskiy, A. A., Turkovskiy, V. H., Muzychak, A. Z., Turkovskiy, Y. V. (2019). Peculiarities of the reactive power flow in the arc furnace supply circuit with improved electromagnetic compatibility. Naukovyi Visnyk Natsionalnoho Hirnychoho Universytetu, 2, 79–86. doi: <https://doi.org/10.29202/nvngu/2019-2/10>
46. Turkovskiy, V. G., Zhovnir, Yu. M. (2001). Obosnovanie effektivnosti primeneniya ustanovki stabilizatsii rezhima v sisteme elektrosnabzheniya dugovyh staleplavil'nyh pechey peremennogo toka. Promyshlennaya energetika, 5, 40–44.
47. IEC 61000-4-15 Ed. 2.0 b:2010. (2010). Electromagnetic Compatibility (EMC) - Part 4-15: Testing and Measurement Techniques. Flickermeter - Functional and Design Specifications.
48. Ivanov, V. S., Sokolov, V. I. (1987). Rezhimy potrebleniya i kachestvo elektroenergii sistem elektrosnabzheniya promyshlennyh predpriyatiy. Moscow: Energoatomizdat, 336.