

*This paper is a continuation of research into the causes and ways to eliminate the generation of self-oscillations in the system of automatic regulation of rotations of the free turbine in the turboshaft gas turbine engines of helicopters. The study of dynamic processes in the system of automatic regulation of free turbine's rotations in a turboshaft GTE has shown that one of the reasons for the development of self-oscillations is the poor performance of the control valve of the type «nozzle-flap» in the rotation regulator's hydraulic drive. At a pump-regulator plant, the criterion for the quality of control valve execution or repair implies that the geometric size of the valve parts and the flow rate of working fluid through the valve when the flap is closed meet the technical requirements. As practice shows, this is not enough. With this approach, valve defects manifest themselves only during the tests of assemblies as part of the engine. This paper proposes a method to examine the characteristics of control valves such as «nozzle-flap», as well as criteria for assessing the quality of their execution. Experimental characteristics of control valves such as «nozzle-flap» for an actual regulator of free turbine rotation frequency are given. New data on the outflow of liquid from the nozzle with a flap have been obtained. It is shown that the destruction of the stagnation zone in the nozzle tip could result in that the valve flow rate increases, which negatively affects the characteristics of the hydraulic drive and regulator in general. A technique has been proposed to improve the stability of the valve's performance by increasing the relative length of the nozzle. It is shown that the most informative characteristic of the valve is the dependence of flow rate on the position of the flap. Based on this characteristic, it is possible to determine the criteria for rejecting valves without testing them as part of the assembly*

**Keywords:** turboshaft engine, self-oscillations, control valve, nozzle-flap, static characteristic, flow rate factor

Received date 30.10.2020

Accepted date 09.02.2021

Published date 19.02.2021

## 1. Introduction

Motor tests of pumps-regulators such as NR-3 (Ukraine) as part of the turboshaft gas-turbine engines such as TV3-117 (Ukraine) often reveal the self-oscillations of the rotation of rotors of the turbocharger and a free turbine in the region of the free turbine revolution regulator (FTRR) operation. The self-oscillations are usually eliminated by replacing the NR-3 pump-regulator. Complete disassembly and inspection of the pump-regulator elements at a plant-manufacturer do not make it possible to determine the cause of the malfunction. Studies into the FTRR static characteristics of assemblies such as NR-3 have shown that self-oscillations develop due to non-linear changes in the static characteristics of FTRR. The causes of the FTRR non-linear characteristics have not been established.

Control valves such as «nozzle-flap» are often used in hydraulic drives and hydromechanical automatic control sys-

# DEVISING QUALITY CONTROL CRITERIA FOR MANUFACTURING CONTROL VALVES OF THE TYPE «NOZZLE-FLAP»

**O. Lytviak**

PhD, Associate Professor\*

E-mail: lom744@ukr.net

**S. Komar**

PhD, Associate Professor

Department of Design

and Strength of Aircraft and Engines

Ivan Kozhedub Kharkiv National Air Force University

Sumska str., 77/79, Kharkiv, Ukraine, 61023

E-mail: sergey.komar.kh@gmail.com

**O. Derevyanko**

PhD, Associate Professor\*

E-mail: asbit@nuczu.edu.ua

**V. Durieiev**

PhD, Associate Professor\*

E-mail: slavonis2122@ukr.net

\*Department of Automatic Security

Systems and Information Technologies

National University of Civil Defence of Ukraine

Chernyshevskaya str., 94, Kharkiv, Ukraine, 61023

Copyright © 2021, O. Lytviak, S. Komar, O. Derevyanko, V. Durieiev

This is an open access article under the CC BY license

(<http://creativecommons.org/licenses/by/4.0>)

tems (ACS). Given their high sensitivity and high gain factors, these elements have become common. A high gain factor is a benefit and, at the same time, a disadvantage of such a control valve. The disadvantage is, first of all, that minor defects of the valve affect its characteristics, and then, many times amplified, transferred to controlling elements. As a result, the linearity of the characteristics of hydraulic drives, as well as the operation of the automatic control system in general, are disrupted. The linear nature of the FTRR static characteristic is largely determined by the linearity of the static characteristics of the control valve. At the same time, when fabricating FTRR control valves, they check only the flow through the valve in a closed position (starting point) while static characteristics are not determined. Therefore, it is a relevant task of practical interest to study the static characteristics of FTRR control valves, to devise methods for assessing the quality of their manufacture in the early stages of production.

## 2. Literature review and problem statement

The steady fluctuations in the linear systems of automatic control (SAC) are termed self-oscillations; they are caused by the non-linearity of SAC elements [1]. The general provisions of mechanical system dynamics are given in detail in [2]. That work notes that the positional regulation or disruption in the characteristics of the control object of the first kind could lead to the development of self-oscillations. Paper [3] addresses the mathematical analysis of self-oscillations and stability in dynamic systems. The authors demonstrated the possibility to ensure the stability of the system by the appropriate choice of control algorithms. Work [4] described the experimental static characteristics of FTRR in the pumps-regulators such as NR-3. It is shown that the actual characteristics of pumps-regulators such as NR-3 may have non-linear features: kinks and breaks of the first kind. However, no defects leading to the kinks and ruptures of FTRR static characteristics were investigated. The development of self-oscillations during the ground-based tests of turboshaft gas-turbine engines (GTE) on hydraulic brake installations is tackled in [5] but in terms of the inconsistency of the characteristics of the hydraulic brake and the propeller of the helicopter as the FTRR control objects. Internal production defects of the pump-regulator, leading to the development of self-oscillations, are not considered. The authors of [6] investigate the impact exerted on the performance of automation equipment by the physical and mechanical properties of the fuel. No phenomena of the development of self-oscillations were revealed.

Control valve of the «nozzle-flap» type represents a nozzle tip, with a limited outflow of liquid in the flooded space. There are many studies addressing the outflow of liquids from nozzles of different shapes. Paper [7] reports extensive research into the dependence of local hydraulic resistances on various factors. However, the outflow of the liquid from the nozzle tips, which is the control valve, is not considered. The impact of Reynolds' number on the hydraulic resistance of round holes in thin walls is explored in [8]. It is shown that in the auto-model region by the number of Reynolds, the hydraulic resistance of the round hole in a thin wall remains constant. However, the cited paper considers the free, non-confined outflow of the liquid. In addition, the effect exerted on hydraulic resistance by the relative length of the hole is not considered. The reported results are very important in calculating and manufacturing jets. These data could be applied for control valves only at the preliminary design stage. Work [9] reports the results of studying the effect of the length and shape of cylindrical nozzles on their hydraulic resistances. It is shown in [10] that the use of a bow at the inlet to the cylindrical nozzle creates a stagnation zone, which has a significant impact on the hydraulic resistance of the nozzle tip. However, the cited works also consider the free outflow from nozzle tips without taking into consideration the effect of the flap on hydraulic resistance. Studies [11, 12] show that the installed flap at the inlet or outlet has a significant impact on the hydraulic resistance of the system nozzle-flap. No conditions for testing are given in [11, 12]. Work [13] outlines the general dependences of the static characteristics of hydraulic and pneumatic drives, without being tied to geometric sizes. Therefore, the reported results cannot be extended to data on the specific size valves. In article [14], the control valve is proposed to be considered as a system of two consistently installed hydraulic resistances:

nozzle and flap. The authors proposed dimensionless design parameters of the outlet slit flap throttle, which determine the modes of flow in the valve. It is shown that the rounding radius of the outlet edge of the nozzle has a significant impact on the valve's flow characteristics. However, the reported experimental data relate to the flow of gas and cannot be used for hydraulic valves. The modernization of aircraft using a turboshaft engine the type of TV3-117 as an auxiliary propulsion system is considered in [15]. The operation of the auxiliary propulsion system of the aircraft involves deep throttle modes, under which the manifestation of self-oscillations in the revolutions of the rotor of a free turbine are most often possible. However, the authors do not consider the possibility of unsatisfactory operation of the system of automatic regulation of the rotations of the free turbine in the engine. The results of experimental studies of the «nozzle-flap» converter are reported in [16]. The joint operation of the control valve and the high-powered pneumatic amplifier created on its base to stabilize the platforms is considered. The characteristics of such amplifiers are not subject to strict requirements; no characteristics of the control valve were studied.

Works [17, 18] tackle the numerical methods to study the characteristics of devices such as nozzle-flap. The numerical modeling of the flow in a control valve such as nozzle-flap is described in [17]. By reconfiguring the inlet to the nozzle section of the valve, the maximum sensitivity of the valve is ensured. The study is of practical interest but the use of the results reported by the authors is limited by the number of cavitation; they require testing by experiment. The issues of numerical modeling of the current in the nozzle-flap-type valve are considered in [18]. For the device in question, the flow rate characteristics were established, and the force impact of the liquid on the flap was calculated during device operation. However, the cited work considers a simplified valve model, which takes into consideration only the ring slit formed by a flap and nozzle, and does not take into consideration the hydraulic resistance of the nozzle itself. Therefore, the application of the reported calculation technique is limited to a very small range of flap movement and makes it possible to determine the parameters of the device only at the initial stage of the device development. A procedure of analyzing the valve's performance base on the frequency characteristics of the amplifying cascade is given in [19]. That procedure is interesting but requires a considerable cost to perform the analysis. The results of flight tests of the turboshaft helicopter engine are reported in [20]. It is shown that under throttle modes there are the self-oscillations of engine parameters. The causes of self-oscillations were not analyzed. A procedure for compensating the zone of insensitivity by means of automation is suggested in [21]. Compensation for the amplifier characterization gap was not considered.

At a manufacturing plant, the criterion for the quality of the «nozzle-flap»-type control valve execution or repair implies that the geometric dimensions of valve parts, as well as the volumetric flow rate of working fluid through the nozzle at the closed flap, meet the technical requirements. As practice shows, this method does not make it possible to evaluate valve operation as part of the pump-regulator. Valve defects appear only at the final stage of production – during the acceptance and testing of assemblies at a manufacturing plant, or when testing assemblies as part of the engine. Testing valves as part of the assembly is very expensive, and, as part of the engine, is also dangerous.

Valve performance is determined by the flow rate characteristic that can be represented by the following dependence:

$$G_V = \mu_V \cdot f_V \sqrt{2\rho(P_U - P_D)}, \quad (1)$$

where  $\mu_V$  is the control valve's flow rate;  $f_V$  is the area of the flow-through section of the valve;  $P_U$  is the pressure before the valve (in the controlled cavity of the hydraulic drive);  $P_D$  is the pressure in the discharge pipe.

In case of constant pressure drop on the valve  $\Delta P = (P_U - P_D)$ , the valve's flow rate characteristic is determined by the area of the flow-through section  $f_V$ , and by the flow rate  $\mu_V$ .

*The area of the flow-through section.* It is generally considered [12, 13] that the working run of the flap is small ( $\delta_Z \leq 0.4d_N$ ); the area of the flow-through section of the valve denotes the area of the flow-through section of the ring slit formed by the end of the nozzle and the flap:

$$f_V = f_Z = \pi \cdot d_N \cdot \delta_Z. \quad (2)$$

However, with large movements of the flap, calculating the flow rate of fluid through the valve using formula (2) could give a qualitatively incorrect result. It is proposed to consider the control valve as a composite element consisting of two consistently installed hydraulic resistances: a cylindrical nozzle (valve nozzle) and a ring throttle (flap). In this case, the total hydraulic equivalent of the control valve could be determined from the following formula:

$$\mu_V f_V = \frac{(\mu_N f_N) \cdot (\mu_Z f_Z)}{\sqrt{(\mu_N f_N)^2 + (\mu_Z f_Z)^2}}, \quad (3)$$

where  $\mu_N$  is the valve nozzle flow rate;  $f_N = \pi \cdot (d_N)^2 \cdot 4^{-1}$  is the area of the flow-through section of the nozzle of the valve;  $\mu_Z$  is the flow rate factor of the flow-through section of the ring slit;  $f_Z = \pi \cdot d_N \cdot \delta_Z$  is the area of the flow-through section of the ring slit.

Assuming  $\mu_V = \mu_N = \mu_Z = 1$ , the equivalent geometric area of the flow-through of the control valve is:

$$f_V = \frac{f_N \cdot f_Z}{\sqrt{f_N^2 + f_Z^2}} = \frac{f_N \cdot \pi \cdot d_N \cdot \delta_Z}{\sqrt{f_N^2 + (\pi \cdot d_N \cdot \delta_Z)^2}}. \quad (4)$$

Fig. 1 shows a change in the area of the flow-through section of the ring slit  $f_Z$  (flap) and the control valve  $f_V$  when opening the flap, calculated from formulae (2) and (4).

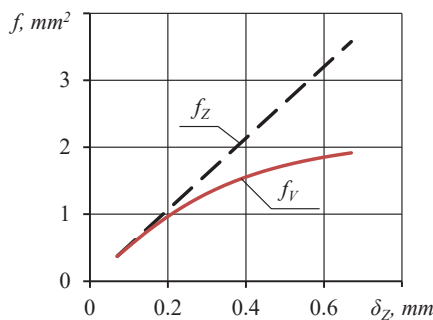

Fig. 1. Change in the area of the flow-through section of the flap and valve

Fig. 1 shows that at values  $\delta_Z \approx 0.15$  mm the difference in determining the valve area is about 5 %, and at values

$\delta_Z \approx 0.4$  mm it reaches 50 %. It follows that ratio (4) should be used to determine the equivalent area of valve  $f_V$  at flap positions  $\delta_Z > 0.15$  mm.

Another parameter that determines the valve's flow rate is the flow rate factor  $\mu_V$ . The flow rate factor [8] is the ratio of the actual flow rate of the fluid flowing through the valve, taking into consideration hydraulic resistance, to a theoretically possible flow rate. It is noted in [12] that the «nozzle-flap»-type valve flow rate does not depend on the position of the flap; at Reynolds numbers  $Re > 1 \cdot 10^2$ , it can be considered constant  $\mu_V = \text{const}$ . It is noted in [13] that at such Reynolds numbers, the valve's flow rate would decrease monotonously when the flap is opened (Fig. 2).

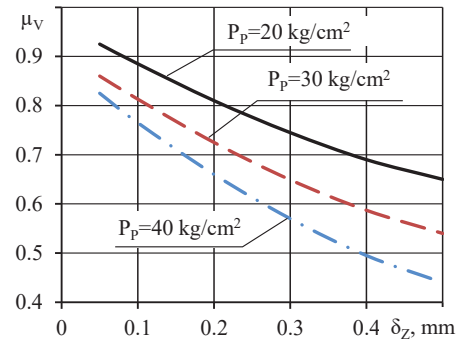

Fig. 2. Effect of the flap position on the «nozzle-flap»-type valve flow rate factor [13]

In a general case, the flow rate factor is a complex function of the Froude hydrodynamic similarity numbers (Fr), Weber (We), Reynolds (Re), as well as the cavitation number ( $\chi$ ), the relative length of the valve nozzle ( $l_c/d_c$ ), and the position of the flap ( $\delta_Z$ ):

$$\mu_V = \mu \left( Fr, We, Re, \chi, \frac{l_N}{d_N}, \delta_Z \right).$$

The geometric parameters that affect the flow rate factor also include the angle of entering the nozzle of valve  $\beta_N$ , the radius of rounding the outlet edge of nozzle  $r_N$ , the relative length of the ring slit between the nozzle end and the flap  $[(d_{N,E} - d_N)/(2d_N)]$ . At this stage of our study, the impact of these parameters was not taken into consideration.

The Froude number (Fr) describes the ratio of the forces of inertia and gravity:

$$Fr = \frac{V_N^2}{g \cdot d_N},$$

where  $g$  is the acceleration of free fall.

This criterion is important for pressure-free currents in open channels. For pressure currents, this criterion can be ignored.

Weber's number (We) characterizes the ratio of forces of surface tension and inertia in the flow:

$$We = \frac{\sigma}{\rho \cdot V_N^2 \cdot d_N},$$

where  $\sigma$  is the surface tension coefficient of the working fluid.

This criterion is important when the liquid outflows into the gaseous environment. When the liquid outflows into the

flooded space (under the level), as is the case at the study site, this criterion may be disregarded.

The cavitation number ( $\chi$ ) characterizes the possibility of cavitation of the working fluid in the considered cross-section:

$$\chi = \frac{P_U - P_{VP}}{\rho \cdot V_N^2 / 2},$$

where  $P_{VP}=0.007 \text{ kg/cm}^2$  is the pressure of vaporization of the working fluid (kerosene).

For the flow in question,  $\chi > 1$ , therefore, the flow is continuous (one-phase), pre-cavitation, so the cavitation number can be ignored.

The Reynolds number (Re) characterizes the ratio of the forces of inertia and viscosity in the flow:

$$\text{Re} = \frac{V_N \cdot d_N}{\nu} = \frac{4Q_N}{\pi \cdot d_N \cdot \nu},$$

where  $Q_N$  is the volumetric flow rate of liquid through the valve;  $\nu$  is the ratio of kinematic viscosity of the working fluid (kerosene).

The flow rate factor depends significantly on the Reynolds number [2, 4]; we cannot ignore this dependence during the calculation and research.

Thus, the flow rate factor of control valve  $\mu_V$  is determined by the Reynolds number, the relative length of the nozzle, and the position of flap  $\delta_N$ :

$$\mu_V = \mu \left( \text{Re}, \frac{l_N}{d_N}, \delta_z \right).$$

Many studies are addressing the dependence of the local hydraulic resistance flow rate factor on Reynolds number [6–9]. However, the data reported in these studies have limitations on the use; for complex structural elements, such as the «nozzle-flap»-type control valve, they require experimental confirmation.

Paper [8] gives data on the dependence of the flow rate factor  $\mu$ , the compression factor  $\xi$ , and the speed factor  $\phi$  for the outflow of liquid from the round holes in the thin wall for pressure flows (Fig. 3).

The thin wall refers to the ratio  $\delta_w/d_h < 0.25$ . In addition, the free outflow of the jet is considered without taking into consideration the influence of the flap and the angle of entering a hole  $\beta = 180^\circ$ .

The results of these studies are applicable for jets whose cross-section is constant. Thus, for jets with a constant flow-through section and a ratio of  $l_w/d_h < 0.25$ , the flow rate factor can be considered constant for  $\text{Re} > 1 \cdot 10^2$ . For  $1 \cdot 10^2 < \text{Re} < 1 \cdot 10^4$ , the flow rate factor is  $\mu = 0.65 \dots 0.68$ . For  $\text{Re} > 1 \cdot 10^4$ , the flow rate factor is  $\mu = 0.65 \dots 0.6$ .

The length of the control valve nozzle also has a significant effect on the fluid flow patterns in the clan nozzle. Paper [9] (Fig. 4) reports the results of studying the dependence of the cylindrical nozzle tip's flow rate factor on its relative length.

It is shown that for short cylindrical nozzle tips in the region of Reynolds numbers  $\text{Re} = 2 \cdot 10^4 \dots 5 \cdot 10^5$  there is a large variation in the flow rate factor. According to the authors, this is due to a change in the current mode in the tip, therefore, it is not recommended to use tips whose parameter is  $l_N/d_N < 1.5$  as

automation equipment elements. The authors of work [11] drew similar conclusions. There is no unstable current for long tips whose parameter is  $l_N/d_N > 3$  while a change in the flow rate factor is predictable (Fig. 5).

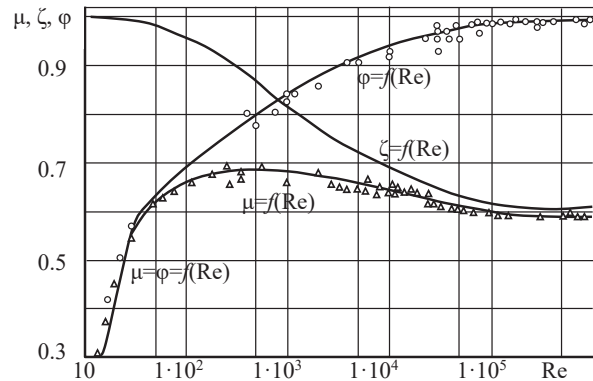

Fig. 3. The dependence of  $\mu, \xi, \phi$  coefficients on Re number [8]

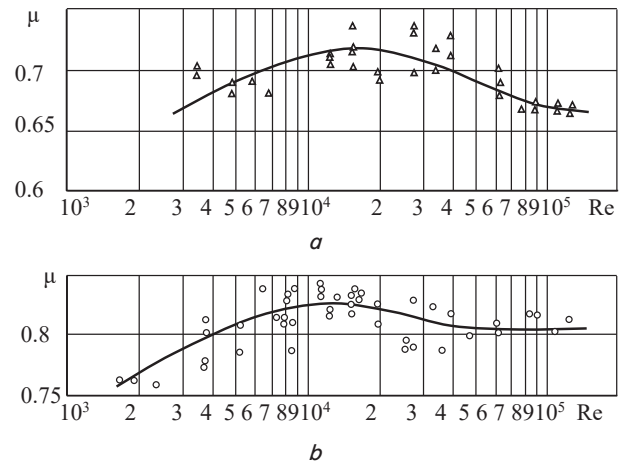

Fig. 4. The dependence of the cylindrical nozzle tip's flow rate factor on Re number: a –  $l_N/d_N = 0.5$ ; b –  $l_N/d_N = 1.0$  [9]

The possibility of unstable current modes in short cylindrical nozzle tips is also noted in work [8]. Given the complexity of the physical processes that occur in a liquid when it flows through the throttling elements of the valve, the valve's flow rate factor cannot be derived theoretically. The flow rate factor is mainly established experimentally; any research in this area is of practical interest.

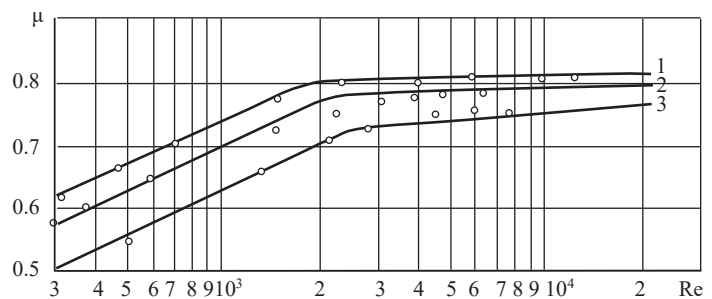

Fig. 5. The dependence of the cylindrical nozzle tip's flow rate factor on Re number: 1 –  $l_N/d_N = 3$ ; 2 –  $l_N/d_N = 5$ ; 3 –  $l_N/d_N = 10$  [9]

Thus, our analysis of the literary data has revealed that the issues related to the outflow of liquid from nozzle tips with flaps remain insufficiently studied. Calculations of the characteristics of the hydraulic drive with the control valve's flow rate factor according to data reported in [12] or [13] do not make it possible to obtain or explain the actual characteristics of the rotation regulator of the free turbine in the NR-3 unit [5]. Therefore, there is a need for a more detailed study of the characteristics of control valves such as «nozzle-flap» based on experimental data, which could make it possible to determine the cause of the poor performance of the hydraulic drive of the regulator.

### 3. The aim and objectives of the study

The aim of this study is to define the patterns of change in the flow rate factor depending on the position of the flap. That would make it possible to devise criteria for early diagnosis of valves without testing them as part of the assembly.

To accomplish the aim, the following tasks have been set:

- to experimentally study the static characteristics of control valves and define the patterns of change in their basic parameters;
- to determine the criteria for rejecting substandard valves according to the defined patterns of change in their parameters;
- to determine the rational design parameters of valves that ensure their stable performance.

### 4. The study materials and methods

The object of this study is the processes and characteristics of the control valve, the type of «nozzle-flap», in the NR-3 pump regulators free turbine rotation regulator. The estimation scheme of the control valve, the type of «nozzle-flap», is shown in Fig. 6.

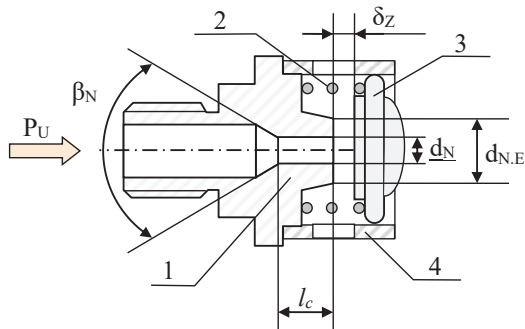

Fig. 6. Estimation scheme of the control valve, the type of «nozzle-flap»: 1 – nozzle; 2 – stabilizing spring; 3 – flap; 4 – jacket

The main structural parameters that determine the nature of the current in the control valve are:  $d_N$  is the diameter of the nozzle;  $d_{N,E}$  is the outer diameter of the nozzle end;  $l_c$  is the length of the cylindrical section of the nozzle;  $l_N/d_N$  is the relative length of the valve nozzle;  $\beta_N$  is the angle of entering the valve nozzle;  $\delta_N$  is the position of the flap. A feature of the control valve design is a self-forcing flap. The stabilization of the position of the flap relative to the plane of the nozzle cut is provided by spring 2.

It is not possible to determine the static characteristic of the control valve as part of the assembly. Therefore, a special device was developed to determine the static characteristics of control valves, the type of «nozzle-flap». The estimation scheme of the device is shown in Fig. 7.

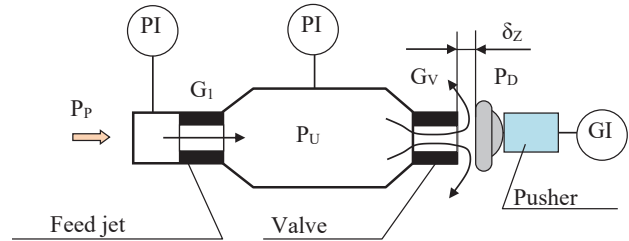

Fig. 7. Estimation scheme of the device to determine the static characteristics of control valves, the type of «nozzle-flap»

The diagram denotes: PI is the pressure indicator; GI is the displacement indicator.

Our study was carried out at the manufacturer's certified bench. The pressure  $P_H$ ,  $P_U$  was measured by gauges whose class of accuracy is 0.6 and a measurement range of 20 kg/cm<sup>2</sup>. The absolute error of pressure measurement is  $\pm 0.12$  kg/cm<sup>2</sup>. The flap was moved by a special pusher along the longitudinal axis. The position of the pusher was measured by the micrometer ICh-10. The error of the movement measurement is  $\pm 0.01$  mm.

The estimation scheme shows that the device to determine the characteristics of control valves is a hydraulic reducer with a constant-section inlet jet and a variable-section outlet jet. Inside the reducer, pressure  $P_U$  is formed, whose value depends on the position of the flap of the control valve  $\delta_Z$ . The dependence of pressure  $P_U$  on the position of the flap is a characteristic of the valve.

The pressure  $P_H$  at the inlet to the device was maintained constant during the experiment. The position of the flap changed in a step of 0.02 mm. The characteristics of the valves were determined at the direct run of the flap (increase by  $\delta_Z$ ). The direct run of the flap is not chosen by chance. In the case of valve «freezing», this fact is easy to detect on the characteristic. The Reynolds number changed during the experiment within the range of  $Re = (1.5...5.6) \cdot 10^3$ .

### 5. The study results

#### 5. 1. The static characteristic of the valve

In the first phase of our study, the characteristics of the regular NR-3 assembly free turbine rotation regulator's control valves with the relative nozzle length  $l_N/d_N = 1.24$  (Fig. 8) were determined. The valves under study passed technical control. All geometric sizes of the valves met technical requirements; no defects were found.

Fig. 8 shows that the starting point of the characteristics ( $\delta_Z = 0$ ) for all the examined valves is the same. However, when the flap position changes, the actual characteristics of valves have individual features such as a different angle of inclination and a «kink» – a stepped change in the angle of inclination.

Therefore, such a criterion as the flow rate of working liquid at a closed flap cannot in principle be used to determine the quality of valve execution or repair.

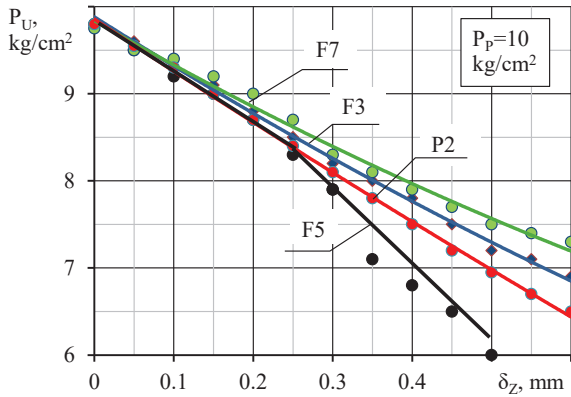

Fig. 8. Characteristics of regular valves  $l_N/d_N = 1.24$

**5. 2. Valve flow rate factor**

The characteristic itself (Fig. 8) is already the base for early valve diagnosis. However, it does not identify the cause of the kinks and cannot be used in the mathematical models of hydraulic drives. As shown above, the most informative parameter that characterizes valve operation is the flow rate factor  $\mu_V$ . An expression defining the joint operation of the feeding jet and the control valve on the device (Fig. 6) was used to determine the flow rate factor of the control valve.

$$G_1 = G_V.$$

The flow rate  $G_1$  through the feeding jet is determined from the following expression:

$$G_1 = \mu_1 f_1 \sqrt{2\rho(P_P - P_U)}, \tag{5}$$

where  $\mu_1$  is the flow rate factor of the feeding jet;  $f_1$  is the area of the flow-through section of the feeding jet;  $P_P$  is the pressure before the feeding jet;  $P_U$  is the variable pressure in the device. As shown above, the value of the hydraulic equivalent of a jet of constant cross-section  $\mu_1 f_1$  can be considered permanent.

By solving equations (1) and (5) in concert, we derived the following expression to determine the hydraulic equivalent of the control valve:

$$\mu_V \cdot f_V = (\mu_1 \cdot f_1) \sqrt{\frac{(P_P - P_U)}{(P_U - P_D)}}. \tag{6}$$

Hence, the valve flow rate factor is:

$$\mu_V = \frac{(\mu_1 \cdot f_1)}{f_V} \sqrt{\frac{(P_P - P_U)}{(P_U - P_D)}}. \tag{7}$$

Fig. 9 shows values of the flow rate factor  $\mu_V$  for control valves, calculated from the results of the experiment (Fig. 8) using formula (7). The area of the flow-through section of the valves was determined from formula (4).

The result of our studies is new data on the outflow of liquid from the nozzle tip with a flap. At low values ( $\delta_N < 0.15 \dots 0.2$ ) the flow rate factor decreases and, with a further increase in  $\delta_N$ , the flow rate factor grows. The characteristic demonstrates an extremum or «spoon» (Fig. 9). The data obtained do not correspond to the known data (Fig. 2) in [13].

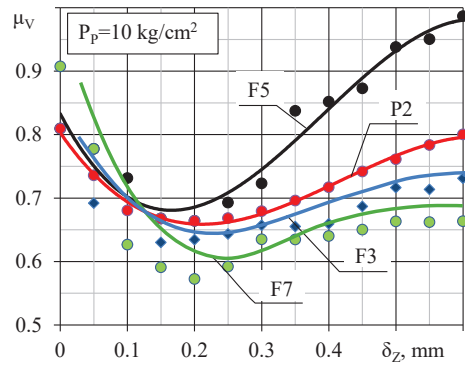

Fig. 9. The flow rate factor of regular valves  $P_P = 10 \text{ kg/cm}^2$ ;  $l_N/d_N = 1.24$

The increase in the flow rate factor at the opening of the flap can be explained by the destruction of the angular vortex in the nozzle of the valve (Fig. 10).

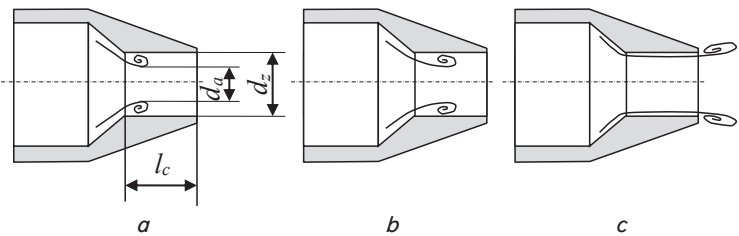

Fig. 10. Flow modes in the control valve nozzle: *a* – vortex formation; *b* – vortex displacement at flap opening; *c* – vortex destruction

The throughput of the nozzle is determined by the diameter of the «actual» cross-section  $d_a$ . In the place of sharp narrowing of the channel, there is an angular vortex (Fig. 10, *a*), which forms the «live» section of the nozzle with a diameter of  $d_a$ . When the flap is opened, the speed of the current in the nozzle increases, and, accordingly, the intensity of the angular vortex increases. The diameter of the «live» section decreases and the flow rate factor decreases as well (Fig. 12, *b*). If the nozzle is not long enough, the vortex goes beyond the nozzle cut and begins to break down (Fig. 10, *c*), the diameter of the «live» section  $d_a$  approaches the geometric diameter  $d_Z$  and the flow rate factor increases.

To prevent the early destruction of the angular vortex when opening the flap and increasing the stable operation of the valve, it is advisable to increase the length of the nozzle.

Fig. 11 shows the results of the study of the effect of stabilizing spring 2 (Fig. 6) on the characteristics of the valve F14.

As it follows from Fig. 11, the stabilizing spring has a positive effect on the valve's characteristics. Without a spring, there is a large scattering of experimental points, which indicates the unstable position of the flap and, as a result, unstable valve operation. The fluid flow rate through the control valve (1) is determined by the hydraulic equivalent  $\mu_V f_V$ . Therefore, any uncalculated increase in the flow rate factor is tantamount to opening the flap, which leads to an uncalculated displacement of the hydraulic drive piston. As a result, a kink or rupture appears on the characteristic of the hydraulic drive or regulator.

Thus, the criteria for rejecting a valve are a sharp increase in the flow rate factor when opening the flap (violation of the current in the valve) or excessive scattering of experimental points on the characteristic (unstable flap position).

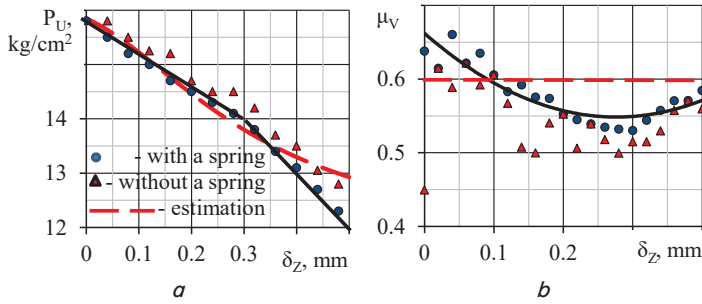

Fig. 11. Effect of stabilizing spring on the characteristics of regular valve F14  $l_N/d_N=1.24$ ;  $P_p=16 \text{ kg/cm}^2$  ( $P_p=16 \text{ kg/cm}^2$ ):  $a$  – the dependence of pressure  $P_U$  on flap position;  $b$  – the dependence of flow rate factor  $\mu_V$  on flap position

**5. 3. Determining the rational structural parameters**

Based on the identified patterns of changes in the flow rate factor when the flap is opened, the second phase of our study implied increasing the relative length of the nozzle from  $l_N/d_N=1.24$  to  $l_N/d_N=3$ . To this end, an experimental F2E valve with an elongated nozzle was manufactured.

Fig. 12 shows the experimental characteristics of the F13 regular valve with the relative nozzle length  $l_N/d_N=1.24$  and the experimental F2E valve with the relative nozzle length  $l_N/d_N=3.0$ .

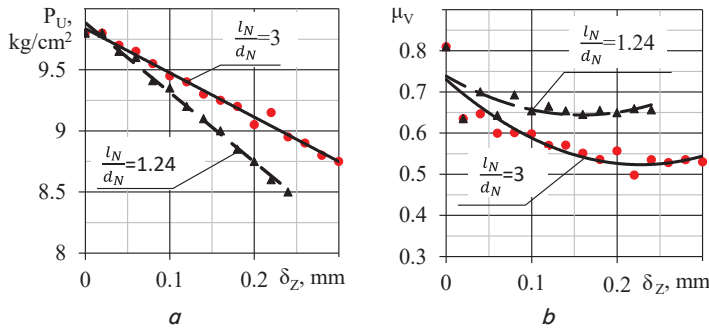

Fig. 12. Characteristics of the regular F13 and experimental F2E valves ( $P_p=10 \text{ kg/cm}^2$ ):  $a$  – the dependence of pressure  $P_U$  on flap position;  $b$  – the dependence of flow rate factor  $\mu_V$  on flap position

Fig. 12 shows that the increase in the relative length of the nozzle has a beneficial effect on the characteristics of the control valve. The static characteristic of the valve becomes smoother (Fig. 12,  $a$ ); for the dependence  $\mu_V(\delta_Z)$ , the «spoon» shifts to the region of larger  $\delta_Z$  values (Fig. 12,  $b$ ). Tests of the F2E valve as part of the NR-3 assembly have confirmed the effectiveness of increasing the relative length of the nozzle.

**6. Discussion of results of studying the static characteristics of control valves the type of nozzle-flap**

The criterion for the quality of the manufacture or repair of control valves such as nozzle-flap at a manufacturing plant is the measurement of the geometric parameters of the valve and the flow rate of working fluid through the valve at the closed position of the flap and the predefined pressure at the inlet. Our study of the control valve’s characteristics has shown convincingly that the accepted method of assessing the quality

of valves does not make it possible to assess the operation of the valve as part of the assembly. The starting point of the characteristic ( $\delta_Z=0$ ) (Fig. 8) is the same in all valves. However, in the working range of the flap positions the characteristics are different, have a different angle of inclination, and may contain kinks (Fig. 8, 11,  $a$ ). The difference in the characteristics of control valves cannot but affect the characteristics of the hydraulic drive and the regulator in general. The most informative characteristic of the valve is the dependence of flow rate factor on the position of the flap  $\mu_V=f(\delta_Z)$  (Fig. 9). A sharp increase in the flow rate factor or the scattering of experimental points indicates valve defects. The proposed technique to improve performance stability by increasing the relative length of the nozzle (Fig. 12) has been confirmed by the testing of such valves as part of the NR-3 assembly.

It should be noted that the current work considers the structural features of the control valve in assemblies of the same type, which is a limitation of this study. If the geometric size or design of the valve is changed, more research is required that could apply the developed methodology. The reasons for the sharp increase in the flow rate factor of individual valves at high values of  $\delta_Z$  (Fig. 9) remained unexplored. Clarifying this issue requires a very finely staged experiment, which was not possible at the manufacturer.

The shortcomings of the reported study results include an indirect assessment of the flow rate factor based on the measured pressures at the characteristic points of the device (Fig. 7). A more accurate way to determine the flow rate factor may be to switch to measuring the flow rate of working fluid through the valve and the pressure drop on the valve. It should also be noted that the study was conducted in the auto-model region of currents based on the Reynolds number, but no generalized data on the effect of pressure on the static characteristics of control valves could be obtained. The region of allowable valve flow rate factor values, which provide for the satisfactory characteristics of the pump-regulator, has remained undetected because of the large costs associated with such parametric studies.

**7. Conclusions**

1. We have defined parameters for diagnosing the operation of nozzle-flap valves in the early stages of production without testing them as part of the assembly. These parameters are the controlled pressure  $P_U=f(\delta_Z)$  and the flow rate factor  $\mu_V=f(\delta_Z)$  over the entire range of the flap positions (valve characteristics). The volumetric flow rate of working fluid through the valve at a closed flap cannot in principle serve as a parameter for assessing the satisfactory performance of the valve as part of the assembly as it is only the starting point of the characteristic ( $\delta_Z=0$ ).
2. The criterion for assessing the operability of the valve is the nature of change in the parameters  $P_U=f(\delta_Z)$  and  $\mu_V=f(\delta_Z)$ . The fracture of the characteristic  $P_U=f(\delta_Z)$ , or a sharp increase in the flow rate factor when the flap is opened indicates a hidden defect in the valve and is the base for rejecting the valve. For the valve studied, the defects should also include a spread of the flow rate factor exceeding 0.05.
3. Our experimental studies have determined a more rational value for the relative length of the nozzle of the

examined valve. Increasing the relative length of the valve nozzle from  $l_N/d_N=1.24$  to  $l_N/d_N=3.0$  ensures more stable characteristics. The characteristics of the valve with an elongated nozzle are more sloping, with no visible kinks, and with a smaller change in the flow rate factor over the working range of the flap positions. The valve with such characteristics operates satisfactorily as part of the assembly, which is confirmed by acceptance and delivery tests.

### Acknowledgments

We express our deep gratitude to Viktor Vasilyevich Volosnyy and Konstantin Sergeyevech Bershadsky (the State Enterprise Kharkiv Engineering Plant «FED», Kharkiv, Ukraine) for supporting and providing effective assistance in conducting experimental research at physical facilities.

### References

- Golnaraghi, F., Kuo, B. (2017). *Automatic Control Systems*. McGraw-Hill Education, 1160.
- Harold, J., Huston, R. (2002). *Dynamics of Mechanical Systems*. CRC Press, 776. doi: <https://doi.org/10.1201/9781420041927>
- Aguilar, L., Boiko, I., Fridman, L., Iriarte, R. (2015). Self-Oscillations in Dynamic Systems. Basel: Birkhäuser, 163. doi: <https://doi.org/10.1007/978-3-319-23303-1>
- Kachanov, P., Lytviak, O., Derevyanko, O., Komar, S. (2019). Development of an automated hydraulic brake control system for testing aircraft turboshaft gas turbine engines. *Eastern-European Journal of Enterprise Technologies*, 6 (2 (102)), 52–57. doi: <https://doi.org/10.15587/1729-4061.2019.185539>
- Lytviak, O. M., Durieiev, V. O., Maliarov, M. V., Chihrin, V. S. (2019). Eksperymentalne doslidzhennia kharakterystyk rehuliatora oborotiv vilnoi turbiny nasosa-rehuliatora typu NR-3. *Materialy dopovidei mizhnarod. naukovo-prakt. konf. «Integrated Computer Technologies in Mechanical Engineering»*. Vol. 2. Kharkiv: Natsionalnyi aerokosmichnyi universytet im. M. Ye. Zhukovskoho «Kharkivskiy aviatsiyniy instytut», 76–79.
- Denisova, E. V., Nasibullaeva, E. Sh., Nasibullayev, I. Sh. (2014). Investigation method of dynamic processes in the fuel elements of automation. *Mehatronika, avtomatizatsiya, upravlenie*, 5, 31–36.
- Nasibullayev, I. Sh., Nasibullaeva, E. Sh., Denisova, E. V. (2015). The dynamics of fluid flow in the technical systems with jets. *Izvestiya Ufimskogo Nauchnogo TSentra RAN*, 4, 20–25.
- Al'tshul', A. D., Kiselev, P. G. (1965). *Gidravlika i aerodinamika*. Moscow: Stroyizdat, 274.
- Stochek, N. P., Shapiro, A. S. (1978). *Gidravlika zhidkostnykh raketnykh dvigateley*. Moscow: Mashinostroenie, 128.
- Polyahov, N. N. (2017). *Aerogidrodinamika*. Moscow: Lenand, 384.
- Petrov, A. G. (2017). *Analiticheskaya gidrodinamika: Ideal'naya neszhimaemaya zhidkost'*. Moscow: Lenand, 368.
- Lepeshkin, A. V., Mihaylin, A. A., Sheypak, A. A. (2019). *Gidravlika i gidropnevmoprivod. Gidravlicheskie mashiny i gidropnevmoprivod*. Moscow: Infra-M, 446.
- Razdoln, M. V., Surnov, D. N. (1973). *Agregaty vozdušno-reaktivnykh dvigateley*. Moscow: Mashinostroenie, 351.
- Pil'gunov, V. (2012). High precision wide-range compressed airflow meter - a fine movements meter. *Science and Education of the Bauman MSTU*, 8, 11–34. doi: <https://doi.org/10.7463/0812.0451962>
- Shmyrov, V., Loginov, V., Fil, S., Khaustov, A., Bondarchuk, O., Kalashnikov, A., Khmel'nikskiy, G. (2020). The modernization concept of aircraft An-26 and An-140 based on the use of a hybrid power system. *Eastern-European Journal of Enterprise Technologies*, 5 (1 (107)), 6–17. doi: <https://doi.org/10.15587/1729-4061.2020.212150>
- Pil'gunov, V. N., Efremova, K. D. (2017). Static characteristics of the pneumatic power amplifier «nozzle-shutter». *Moskovskogo gosudarstvennogo tehnikeskogo universiteta MAMI*, 2 (32), 40–48.
- Xinbei, L., Vladimir, L., Songjing, L. (2018). Performance and Flow Field Analysis of Flapper Deflection Servo Valve. 2018 Global Fluid Power Society PhD Symposium (GFPS). doi: <https://doi.org/10.1109/gfps.2018.8472394>
- Lerner, D. L. (2013). *Harakteristiki ustroystva soplo-zaslodka pri obratnom techenii*. *Vestnik permskogo natsional'nogo issledovatel'skogo politehnicheskogo universiteta. Aerokosmicheskaya tehnika*, 35, 85–100.
- Li, C., Choudhury, M. A. A. S., Huang, B., Qian, F. (2014). Frequency analysis and compensation of valve stiction in cascade control loops. *Journal of Process Control*, 24 (11), 1747–1760. doi: <https://doi.org/10.1016/j.jprocont.2014.09.009>
- Yildirim, M. T., Kurt, B. (2018). Aircraft Gas Turbine Engine Health Monitoring System by Real Flight Data. *International Journal of Aerospace Engineering*, 2018, 1–12. doi: <https://doi.org/10.1155/2018/9570873>
- Savelyev, D. O., Gudim, A. S., Solovev, D. B. (2019). Stabilizing the Transients in the Objects and Systems Controlling the Compensation of Nonlinear ACS (Automatic Control System) Elements. 2019 International Science and Technology Conference «EastConf.» doi: <https://doi.org/10.1109/eastconf.2019.8725324>