

A vegetable storage facility is an energy-consuming object with distributed parameters. The quality of product storage depends on the microclimate in the vegetable storage facility: current temperature, humidity, and carbon dioxide level. Existing temperature controllers in a vegetable storage facility use a two-position law of control, which leads to the consumption of excess energy and product spoilage.

The purpose of the study is to improve the work of the controller in the process of product storage at the storage phase due to closing the two-position controller through feedback in the form of a first-order aperiodic link.

To achieve the goal, the procedure for calculating the transfer function of a control object through the equation of thermal balance was used. This procedure made it possible to take into consideration the parameters of a vegetable storage facility: the area and the type of thermal insulation material of floorings, the weight, and the type of a stored product, as well as thermal energy supplied to the vegetable storage facility.

Based on the heat balance equation, the nature of the operation of controlling elements, transfer functions of a vegetable storage facility without a product, and the vegetable storage facility filled with a product, were calculated. The heat model of a vegetable storage facility was constructed in the MATLAB Simulink environment (USA) to check the algorithms of the temperature field control.

The product storage for 180 days with changes in the daily temperature of outdoor air from minus 8 °C to plus 2 °C and changes in humidity from 50 % to 100 % was modeled.

According to the results of modeling, it is possible to conclude that the addition of an aperiodic link to the feedback of the two-position controller will enable taking into consideration the inertia of a control object. This allows decreasing the maximum error in control of self-oscillations to 0.15 °C and decreasing the total operation time of controlling elements by 13 %

Keywords: control system, vegetable storage facility, temperature stabilization, microclimate, mathematical model, vegetable storage

DEVISING A METHOD TO IMPROVE THE ACCURACY OF MAINTAINING THE PRE-SET TEMPERATURE AND HUMIDITY CONDITIONS AT A VEGETABLE STORAGE FACILITY UNDER A FOOD STORING MODE

Petro Kachanov

Doctor of Technical Sciences, Professor*

E-mail: kpa@kpi.kharkov.ua

Oleh Yevseienko

PhD, Senior Lecturer*

E-mail: olegyevseienko@gmail.com

Nataliia Yevsina

PhD, Associate Professor*

E-mail: nataliia.yevsina@khpi.edu.ua

*Department of Automation and

Control in Technical Systems

National Technical University

«Kharkiv Polytechnic Institute»

Kyrpychova str., 2, Kharkiv, Ukraine, 61002

Received date 26.02.2021

Accepted date 06.04.2021

Published date 30.04.2021

How to Cite: Kachanov, P., Yevseienko, O., Yevsina, N. (2021). Devising a method to improve the accuracy of maintaining the pre-set temperature and humidity conditions at a vegetable storage facility under a food storing mode. *Eastern-European Journal of Enterprise Technologies*, 2 (2 (110)), 89–98. doi: <https://doi.org/10.15587/1729-4061.2021.229844>

1. Introduction

A vegetable storage facility (Fig. 1) is a building with an area of up to 3000 m², which is used to get rid of moisture, preserve and bring a product to its proper condition before selling it.

In the process of product storage in a vegetable storage facility, it is necessary to monitor the maintenance of the microclimate: the temperature mode of a product with the assigned level of accuracy, relative humidity of a product, and the carbon dioxide level (CO₂) [1]. A dangerous event that can lead to product spoilage is the formation of condensate on a product (dew fallout).

According to research, in the XXI century, the population increased by 35.5 % up to 7.7 billion people. According to the UNO Department for Economic and Social Affairs,

the world's population will continue to grow and will be as high as 11 billion by 2050. Along with the growth of the world's population, the demand for food is also growing. To assess a person's need for vegetables, the "borsch ingredients index", which includes potatoes, cabbage, onions, carrots, and beets, is used. This index is seasonal in nature and depends on the capability to meet the need due to internal storage in vegetable storage facilities. Therefore, seasonality and the need for products create the need for their long-term and high-quality storage [2].

The total volume of losses of stored products due to non-compliance with temperature and humidity conditions can reach 40 %. This can occur due to weight loss during breathing, evaporation, and germination of products. Serious consequences can be caused by mechanical damage, especially at the final stage of storage, when as a result

of maturation, vegetables are softened and their strength decreases [3]. These factors affect consumer properties of products and lead to a decrease in the sale price.

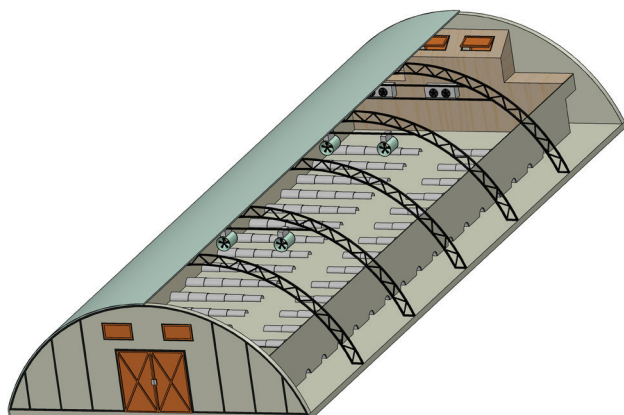

Fig. 1. General view of the bulk-type vegetable storage facility

Violation of storage modes can lead to condensation of moisture on a product, which creates a favorable environment for the growth of fungi and other microorganisms [4].

The storage quality of a product depends on the microclimate in the vegetable storage facility: current temperature, humidity, and carbon dioxide level. Existing temperature controllers in the vegetable storage facility use a two-position control law, which leads to the consumption of excess energy and product overheating [5].

Modernization of the product storage industry requires a large amount of refrigeration equipment, which demands the creation of technological measures for its energy efficiency. Even insignificant energy saving (up to 5 %) at the reduction of losses for refrigeration or heating equipment will enable a significant reduction of the energy burden on the agricultural sector of countries [5].

Thus, the problem of enhancement of the product storage quality cannot be solved without the development of new or the improvement of existing methods for temperature control of vegetable storage facilities. Due to the constant population growth and the demand for food, the products' sensitivity to the storage conditions, the problem of high-quality storage of vegetables is a relevant task.

2. Literature review and problem statement

A number of publications, starting in the 1970s, deal with the problem of proper cultivation and storage of vegetables [6–10]. That is why it has long been known what temperature and relative humidity should be maintained for each type of product and for what period a product should be left in the refrigerator [11].

In the countries of the European Union, the microclimate of vegetable storage facilities has been controlled since the early 2000s. The main manufacturers of controllers for maintaining the microclimate are companies Tolsma (Holland) [9], Mooij Agro (Holland) [10]. Manufacturers of these controllers offer devices designed to control the microclimate of bulk and container-type vegetable storage facilities. These controllers are used to operate controlling elements: heaters, refrigerators, fans, and valves. Controllers also collect information about the temperature of a product, outdoor air, the air in the storage fa-

cility, product humidity, CO₂ level, ethylene level, and the state of controlling elements [9]. The log of emergencies, calculation of the operation time of controlling elements, displaying information about the current state of the system on the computer screen are proposed as additional mechanisms [10].

One of the main problems in the organization of microclimate control is maintaining the product temperature at minimal electricity costs [12], that is why, for example, it is possible to switch on fans only in the evening or at night. The primary source of influence on the product microclimate is outdoor air. Before using a refrigerator or a heater, only a slight increase in the product temperature due to switching on is allowed if the outdoor air does not arrive. However, such frequent increases may affect the product quality.

As shown in paper [13], temperature and humidity are important indicators that affect the product quality throughout the entire storage phase. Attempts to improve the quality found implementation in the modern concept of the Internet of things [14], but this article did not deal with the temperature control but showed that nine temperature sensors and a measurement period equal to 16 minutes are not enough to monitor the parameters of a vegetable storage facility with the dimensions of 8×30×5 m. That is why the site should be studied as an object with distributed parameters.

Paper [15] shows that special construction and engineering measures should be observed to reduce the heat losses of the vegetable storage facility during construction. Article [16] solves the problem of developing an automated interactive system to optimize the introduction of water, nutrients, and pesticides for a vegetable storage facility and to prepare vegetables for storage.

Given the fact that a vegetable storage facility is an energy-consuming object with distributed parameters, it is necessary to consider the possibility of controlling its temperature using predictive algorithms. This approach is used in paper [17], but for another object with distributed parameters.

The most common method for temperature control in a greenhouse is the addition of a PID controller to the heating circuit [18] due to its relative simplicity. However, it has a limited control quality, because it does not take into consideration the uncertainty of parameters [19].

The use of fuzzy logic [18, 20] makes it possible to obtain high accuracy of control, which is difficult to apply in practice due to the need for learning of the object model [21].

In paper [19], the method for adaptive iterative temperature control in a greenhouse was proposed and a software adaptation algorithm that evaluates the error of control and adjustment of control influence was developed. However, the adaptation process itself lasts 1 day. At this time, the product temperature can rise by the magnitude of up to plus 2 °C above the assigned value, which is undesirable for product storage in a vegetable storage facility. This paper does not substantiate the choice of initial configuration coefficients for the applied controller.

The author of article [2] developed an unstable three-dimensional computational model of hydrodynamics to assess the distribution of temperature and relative humidity in a refrigerator fully loaded with apples. In this research, the set temperature was maintained at the level of +2 °C, and the temperature distribution in a refrigerator chamber was visually represented. However, the control method gave an error of +0.5 °C, which is typical of two-position control.

An attempt to refine the existing method for two-position control was made in research [4]. The declared error of

the proposed method in certain areas is +0.11 °C. However, modeling was carried out without changing the indicators of outdoor air and at a time interval equal to 1 hour. The selected modeling time is quite short compared to the overall product storage cycle.

In article [5], the authors concluded that the inertia of the potatoes bulk and the design features of the potatoes storage facility determine the expediency of creating a multi-channel system for automatic control. The created new controllers and models must include information about the current state of a product and the design of the vegetable storage facility. That is why having information about the amount of produce, one can make changes to the coefficients of the model in the process of storage. It is also believed that in order to reduce the product losses, it is necessary to reduce the amplitude of self-oscillations of temperature control.

Thus, the results of our review of publications revealed a series of problems associated with the choice of the method for controlling the temperature and humidity modes. Some methods, when used, cause high computational complexity [18, 20, 21]. A number of models do not contain any information about the current state and the number of products stored [2, 4].

The above suggests that it is advisable to conduct research into the problem of maintaining the set microclimate of a vegetable storage facility to ensure the proper product quality.

3. The aim and objectives of the study

The purpose of the research is to improve the algorithm of operation of the two-position controller through the use of an aperiodic link in the feedback circuit, which will increase the accuracy of temperature control of a vegetable storage facility.

To achieve the set goal, it is necessary to solve the following tasks:

- to obtain transfer functions of an empty vegetable storage facility and a vegetable storage facility filled with a storage product;
- to develop a mathematical model of a vegetable storage facility to study the temperature and humidity processes;
- to carry out modeling with maintaining the set temperature and humidity of the product.

4. Materials and methods for construction of a model of a vegetable storage facility

4.1. Description of the method for constructing a model of a vegetable storage facility for modeling

MATLAB Simulink (USA) program was used to simulate the temperature and humidity modes. In this program, the model of a vegetable storage facility was constructed with the help of the apparatus of transfer functions.

The transfer functions of a vegetable storage facility were obtained using the equation of heat balance, which is put down through the equation of heat losses and the equation of heating.

Heat losses of a vegetable storage facility through enclosing structures Q are determined from the following formula:

$$Q = \frac{S_{ec}(t_{in} - t_{out})}{R_{ec}}, \tag{1}$$

where S_{ec} is the area of the surface of enclosing structures, m^2 ; R_{ec} is the resistance to heat transfer of the enclosing structure, $m^2 \cdot ^\circ C / W$; t_{in} is the air temperature in a vegetable storage facility, $^\circ C$; t_{out} is the temperature of the outdoor air, $^\circ C$.

Thermal resistance of a homogeneous enclosure or layer R , which is part of a multilayer enclosure, is calculated from formula:

$$R = \frac{\delta}{\lambda}, \tag{2}$$

where δ is the thickness of layer, m ; λ is the heat conductivity factor of material, $m^2 \cdot g \cdot ^\circ C / kcal$.

The temperature in a vegetable storage facility is controlled by a channel heater, a cooler, and inlet and outlet valves. Humidity is controlled with the help of ceiling heaters and fans.

The transfer function of a fan can be described as a first-order aperiodic link

$$W_f(p) = \frac{k_f}{T_f p + 1}, \tag{3}$$

the transfer coefficient k_f of which is determined from the following formula:

$$k_f = \frac{A}{P_c}, \tag{4}$$

where T_f is the time constant of fan operation, s ; A is the fan efficiency, m^3/s ; P_c is the power consumption, W .

A valve is a controlling device that controls airflows. The valve mechanism consists of a stationary case and a moving element. The amount of air passing through a valve depends on the area of the cross-section of an inlet valve and the pressure difference created by a fan.

A valve is described by the transfer function of a proportional link

$$W_{PO}(p) = \frac{\Delta\%EC}{\Delta Q}, \tag{5}$$

of transfer coefficient, determined by the characteristic for a certain range of a change in air consumption (Table 1), where $\Delta\%CE$ is the percent of valve opening by the controlling elements, ΔQ is the amount of heat incoming through the inlet valves.

Table 1 shows the ratio of the assigned value of the percent of valve opening to the amount of heat entering the vegetable storage facility. Magnitude Q/Q_{max} from Table 1 is found by dividing the input signal Q by the maximum value of the output signal Q_{max} . In an actual site, this characteristic may change due to the characteristics of the controlling element and the design features of the valve.

Table 1

Coefficient of valve transfer								
% CE	0	15	30	45	60	75	90	100
Q/Q_{max}	0	0.15	0.3	0.45	0.6	0.75	0.9	1

The transfer function of the controlling element that moves the valve is an integrating link

$$W_{ec}(p) = \frac{1}{T_i \cdot p} \tag{6}$$

The value of time constant T_i is determined by the characteristics of a particular controlling element.

After the air is mixed in the air channel, a channel heater with a channel fan is used to increase or decrease the temperature.

A cooler is a compressor-capacitor unit, which is located inside the vegetable storage facility. The amount of heat Q produced to heat the air in the vegetable storage facility is determined from the following formula

$$Q = C_a \cdot G_a \cdot (t_{set} - t_{out}), \tag{7}$$

where C_a is the specific thermal capacity of the air, J/(kg·°C); G_a is the mass air flow, kg/s; t_{set} is the necessary heating temperature, °C; t_{out} is the temperature of the outdoor air, °C;

Mass air flow of heated air G_a is determined from the following formula:

$$G_a = L_a \cdot \rho_a, \tag{8}$$

where L_a is the volumetric amount of heated air, m³/h; ρ_a is the air density, kg/m³.

When the ventilation is off, the product temperature increases due to the heat of self-heating. The physiological basis of this is the product “breathing” at poor ventilation of the storage facility. This heat supply is not taken into consideration in the developed model.

Thermal power supplied to a vegetable storage facility with the help of channel fans Q is consumed to heat the air in the vegetable storage facility Q_{vs} , product heating Q_{pr} and to cover the heat energy consumption through the enclosing structures Q_{ec}

$$Q = Q_{vs} + Q_{pr} + Q_{ec}. \tag{9}$$

In an infinitely short period, the power supplied to a vegetable storage facility $Qd\tau$ is consumed for heating the vegetable storage facility by dt degrees without product $G_{vs} \cdot C_{vs} dt$ and for heating product $G_{pr} \cdot C_{pr} dt$. Supplied power $Qd\tau$ is also consumed to cover power consumption through enclosing structures $k_{ec} \cdot S_{ec} \cdot \Delta t_{in} d\tau$. That is, the differential equation of heat balance takes the following form:

$$Qd\tau = G_{vs} \cdot C_{vs} dt + G_{pr} \cdot C_{pr} dt + k_{ec} \cdot S_{ec} \cdot \Delta t_{in} d\tau. \tag{10}$$

In equation (10) $\Delta t_{in} = t_{in} - t_{out}$.

Convert the resulting equation (10) into (11) to (13):

$$Qd\tau = G_{vs} \cdot C_{vs} \frac{dt}{d\tau} + G_{pr} \cdot C_{pr} \frac{dt}{d\tau} + k_{ec} \cdot S_{ec} \cdot \Delta t_{in} \frac{dt}{d\tau}, \tag{11}$$

$$\frac{Qd\tau}{k_{ec} \cdot S_{ec}} \cdot \frac{dt}{d\tau} = \frac{G_{vs} \cdot C_{vs}}{k_{ec} \cdot S_{ec}} \cdot \frac{dt}{d\tau} + \frac{G_{pr} \cdot C_{pr}}{k_{ec} \cdot S_{ec}} \cdot \frac{dt}{d\tau} + \Delta t_{in}, \tag{12}$$

$$\frac{Qd\tau}{k_{ec} \cdot S_{ec}} \cdot \frac{dt}{d\tau} = \frac{G_{vs} \cdot C_{vs}}{k_{ec} \cdot S_{ec}} \cdot \frac{dt}{d\tau} + \frac{G_{pr} \cdot C_{pr}}{k_{ec} \cdot S_{ec}} \cdot \frac{dt}{d\tau} + \Delta t_{in}. \tag{13}$$

Designate $\frac{G_{vs} \cdot C_{vs}}{k_{ec} \cdot S_{ec}}$ as the time constant of the vegetable storage facility T_{vs} , and $\frac{G_{pr} \cdot C_{pr}}{k_{ec} \cdot S_{ec}}$ as T_{pr} . Then we obtain expressions (14) and (15)

$$\frac{Q}{k_{ec} \cdot S_{ec}} = (T_{vs} + T_{pr}) \cdot \frac{dt}{d\tau} + t_{in} - t_{out}, \tag{14}$$

$$\frac{Q}{k_{ec} \cdot S_{ec}} + t_{out} = (T_{vs} + T_{pr}) \cdot \frac{dt}{d\tau} + t_{in}. \tag{15}$$

From this equation, we obtain the transfer function of a vegetable storage facility

$$W_{vs}(p) = \frac{\frac{Q}{k_{ec} \cdot S_{ec}} + t_{out}}{(T_{pr} + T_{vs}) \cdot p + 1}. \tag{16}$$

The transfer function of a vegetable storage facility without a product takes the following form:

$$W_{vs}(p) = \frac{\frac{Q}{k_{ec} \cdot S_{ec}} + t_{out}}{T_{vs} \cdot p + 1}. \tag{17}$$

The larger the mass, the thermal capacity of a storage facility and a product, and the less the thermal conductivity of their external and internal enclosing structures, the higher the time constant ($T_{vs} + T_{pr}$) of a vegetable storage facility. The obtained model takes into consideration the heat energy supplied to a vegetable storage facility, the area of floorings, the mass of the vegetable storage facility filled with a product.

4. 2. Description of the modeled object

The modeled vegetable storage facility has dimensions of 12×8×4 m and a capacity of 100 tons. The protective structure includes walls made of metal profile (sandwich panels) that are 100 mm thick with mineral wool insulation. The roof is also made of an insulated metal profile that is 120 mm thick. Thermal conductivity coefficient of the enclosing structure $\lambda = 0,043$ W/m·K.

The 3.0 kW channel heater, inlet and outlet valves, a circulator fan, and ceiling fans are mounted in the vegetable storage facility (Fig. 2).

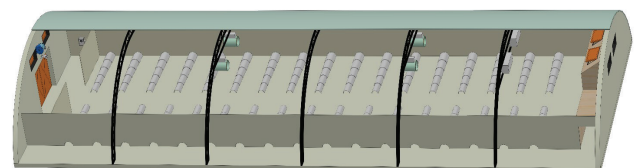

Fig. 2. Location of controlling elements in the vegetable storage facility

Axial fans are used in the vegetable storage facility. The fan has an engine power of 1.5 kW, a rotational rate of 3,000 min⁻¹, a performance of 9,600–15,000 m³/h.

The outdoor air entering the vegetable storage facility through the inlet valves is mixed with the air in the storage facility in the air channel, then heated up to the pre-set temperature and enters the air channel. The amount of air passing through the air channel is determined by the fan power. Passing through bulk, the air cools/heats or drains/moistens the product, depending on the storage mode.

The product temperature sensors are mounted evenly in the vegetable storage facility. The temperature of the product for bulk storage is controlled according to the average value of all sensors.

The setting of the product temperature in a vegetable storage facility for the storage mode, depending on the type of a product is shown in Table 2, where t_{out} is the temperature of the outer air, °C; t_{set} is the necessary heating temperature, °C; sp is the seed potatoes; tp is the table potatoes; on is the onions; cab is the cabbage; car is the carrot.

Table 2

Setup of product temperature

Product	sp	tp	on	cab	car
$t_{st}, °C$	3.0	5	1	1	1
$t_{set}, °C$	18	18	30	18	18

Table 3 shows the intensity of product ventilation is given in the phases of curing, cooling, and storing, where ff is industrial potatoes.

Table 3

Ventilation intensity $m^3/t \cdot h$

Type of stored product	$t_{out} > \text{minus } 20 °C$	$t_{out} < \text{minus } 20 °C$
ff	70	50
sp	100	70
on, cab, car	150	100

For all types of products in the storage phase, it is allowed to use outdoor air under the following conditions:

- 1) minimum difference in the temperature of the outdoor air and the product temperature is more than plus 2.0 °C;
- 2) maximum difference in the temperature of the outdoor air and the product temperature is below plus 15.0 °C;
- 3) to use outdoor air, its temperature should be above minus 10.0 °C so as not to freeze the product and so that the supply and exhaust valves should not freeze;
- 4) relative humidity of the outdoor air should be in the range from 60 % to 100 % (for onions, from 10 % to 90 %);
- 5) the difference between the estimated dew point temperature and the product temperature should be more than 3.0 °C;
- 6) the setup of the air heating temperature with the help of a heater is given in Table 2;
- 7) the setup of humidity in a vegetable storage facility should be in the range of 72 % to 78 %.

5. Results of studies on maintaining the temperature and humidity modes of a vegetable storage facility

5.1. Obtaining the transfer functions of the control object

The source data for the modeled vegetable storage facility are given in Table 4.

Using the data from Table 4, (16) and (17), we received transfer functions without (18) and with (19) a product for outside air temperature $t_{out} = \text{minus } 10 °C$

$$W_{ts}(p) = \frac{-10}{0.29 \cdot p + 1}, \tag{18}$$

$$W_{ts}(p) = \frac{117.91}{409.5 \cdot p + 1}. \tag{19}$$

In expression (18), Q equals 107,213.4 kJ, in expression (19), Q equals 0 kJ.

Table 4

Source data for the construction of transfer functions of a vegetable storage facility

Parameter	Value	Formula for calculation
Length of a vegetable storage facility a , m	12	–
Width of a vegetable storage facility b , m	8	–
Height of a vegetable storage facility c , m	4	–
General volume of a vegetable storage facility V_{ec} , m^3	384	$V_{ec} = a \cdot b \cdot c$
Stored product	Seed potatoes	–
Product weight G_{pr} , t	100	–
Air volume in a vegetable storage facility V_{ts} , m^3	192	–
Volume of a vegetable storage facility filled with product V_{pr} , m^3	192	–
Measured time of transport delay of a vegetable storage facility, h	1	–
Air density ρ_a , kg/m^3	1.27	–
Product density ρ_{pr} , kg/m^3	1,168	–
Mass number of the air, kg	243.84	$G_{ts} = V_{ts} \cdot \rho_a$
Area of enclosing structure for four walls S_w and roof S_r , m^2	254	$S_{ec} = 4 \cdot S_w + S_r$
Heat transfer resistance of enclosing structures, $m^2 \cdot h \cdot °C/kcal$	2.33	formula (2)
Heat transfer resistance of the roof, $m^2 \cdot h \cdot °C/kcal$	2.79	formula (2)
Average coefficient of heat transfer of the enclosing structure k_{ec} , $m^2 \cdot h \cdot °C/kcal$	0.7876	$k_{ec} = \frac{1}{R_{ec}} = \frac{1}{2.33} + \frac{1}{2.79}$
Average coefficient of heat transfer of the enclosing structure k_{ec} , $kJ/(m^2 \cdot h \cdot °C)$	3.3	$k_{ec} \cdot 4.19$
Specific heat capacity of the air C_a , $kJ/(kg \cdot °C)$	1.005	–
Specific heat capacity of potatoes C_{pr} , $kJ/(kg \cdot °C)$	3.43	–
Time constant of vegetable storage facility without product $T_{(ts)}$, h	0.29	$\frac{G_{ts} \cdot C_{ts}}{k_{ec} \cdot S_{ec}}$
Time constant of vegetable storage facility with product $T_{(ts+pr)}$, h	409.5	$\frac{G_{ts} \cdot C_{ts} + G_{pr} \cdot C_{pr}}{k_{ec} \cdot S_{ec}}$
Temperature of outdoor air t_{out} , °C	minus 10	–
Heat transfer Q , kJ	107,213.4	formula (7), Table 3
Fan power P_c , kW	1.5	–
Fan efficiency A , m^3/h	10,000	–
Transfer coefficient of a fan	6.67	formula (4)

Thus, the transfer function of a fan for the time constant that is equal to 0.0083 h, was obtained in (20)

$$W_f(p) = \frac{k_f}{Tp + 1} = \frac{6.67}{0.0083 \cdot p + 1}. \tag{20}$$

The resulting transfer function of a vegetable storage facility filled with a product (18) is used to construct a mathematical model of a vegetable storage facility.

5. 2. Synthesis of the mathematical model of a vegetable storage facility filled with the product

According to the calculations obtained in Table 4, a mathematical model of a vegetable storage facility at the constant temperature of the outdoor air, which is minus 10 °C, was constructed (Fig. 3).

The transitional characteristic at heating the air with channel heaters at a constant temperature of outdoor air, which is minus 10 °C, is shown in Fig. 4.

Fig. 4 shows that the constant value of the air temperature in a vegetable storage facility is 117.5 °C, which significantly exceeds the required temperature for the storage mode (Table 2).

Thus, it is necessary to introduce a contour for controlling the air temperature in the premises.

Control is carried out with the help of the two-position law of control, often used in temperature control of a vegetable storage facility. If the deviation of the current product temperature from the pre-set temperature does not exceed minus 0.3 °C, the signal at the output of the thermostat is unity, otherwise, it is equal to zero.

The structural diagram of a closed temperature control system with a delay link is shown in Fig. 5.

The modeling circuit that takes into consideration the temperature in the channel, the temperature, and humidity of the outdoor air, the temperature, and humidity in a vegetable storage facility, is shown in Fig. 6.

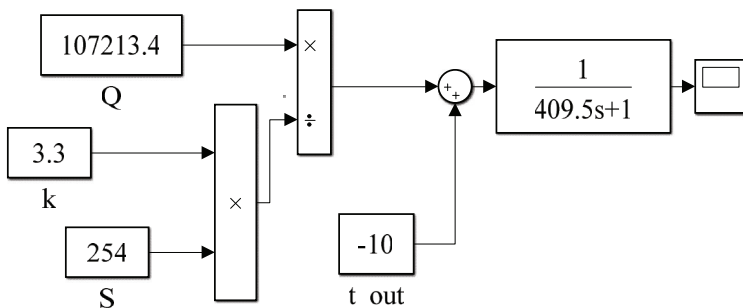

Fig. 3. Schematic showing the mathematical model of a vegetable storage facility

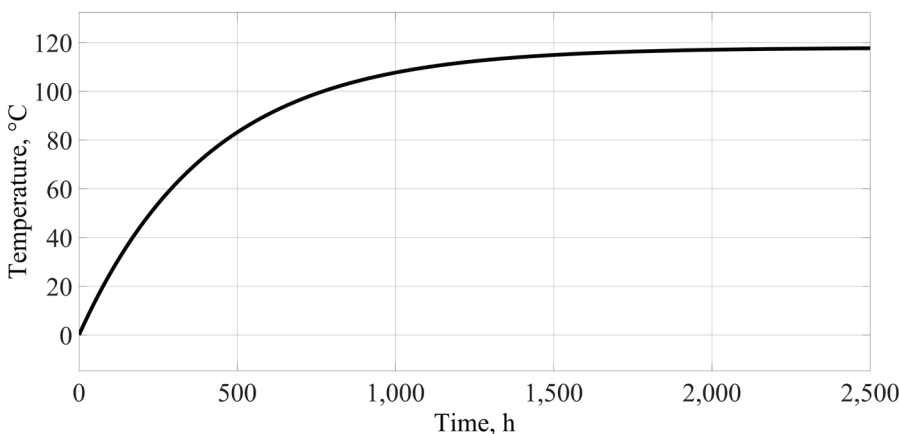

Fig. 4. Transitional characteristic of a vegetable storage facility

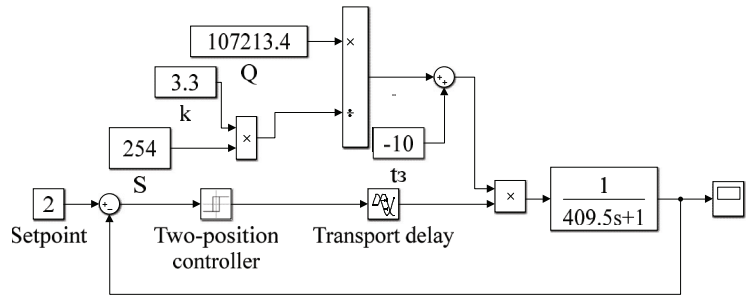

Fig. 5. Diagram of the mathematical model of a vegetable storage facility using a two-position controller

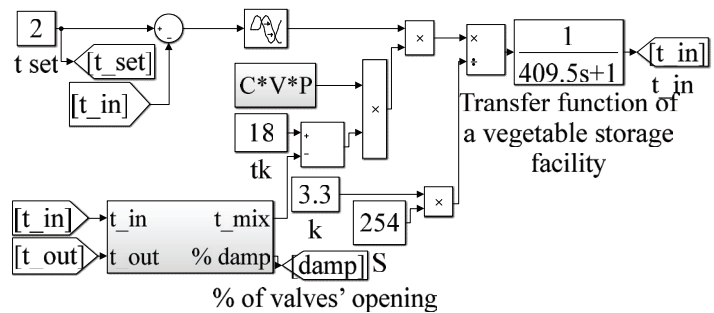

Fig. 6. Schematic showing the mathematical model of a vegetable storage facility using a two-position controller that takes into account the temperature and humidity of outdoor air

The circuit contains the developed mathematical model of a vegetable storage facility, a two-position controller, a unit of transport delay, the pre-set temperature in a vegetable storage facility. This mathematical model describes most of the current vegetable storage facilities of the bulk type.

5. 3. Modeling the maintenance of pre-set temperature and humidity modes at the product storage phase

The following conditions were assigned for modeling: the temperature of the outdoor air during the day takes a value from minus 8 °C to plus 2 °C (Fig. 7). The humidity of the outdoor air varies from 50 % to 100 % according to the diagram shown in Fig. 8.

Laying vegetables for storage can take up to 6 months, so modeling time is taken equal to 180 days:24 h=4,320 hours.

The results of modeling the air temperature in a vegetable storage facility t_{in} , depending on a change in the temperature of the outdoor air t_{out} and humidity h_{out} provided the conditions given in Tables 2–4, shown in Fig. 9, are met.

According to the results of Fig. 9, the value of amplitude and that of the period of self-oscillations was 0.6 °C and 154 h. When the first-order aperiodic link is added to the controller feedback and coefficients T, k are determined, the circuit takes the form presented in Fig. 10.

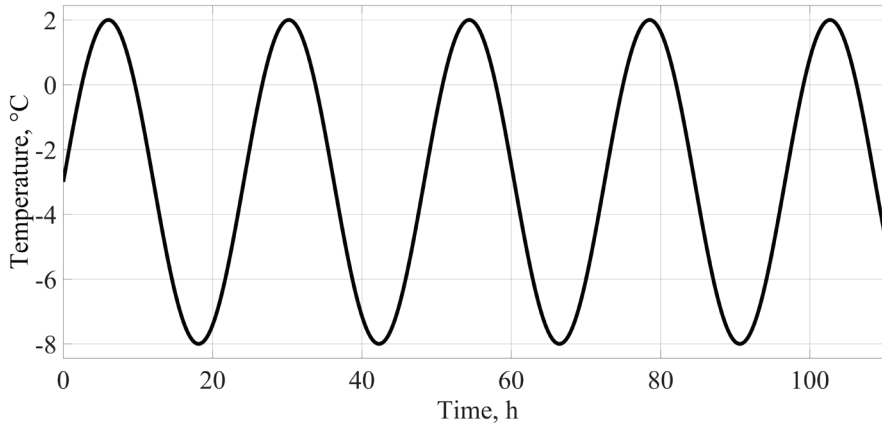

Fig. 7. Chart of changes in outdoor temperature from minus 8 °C to plus 2 °C

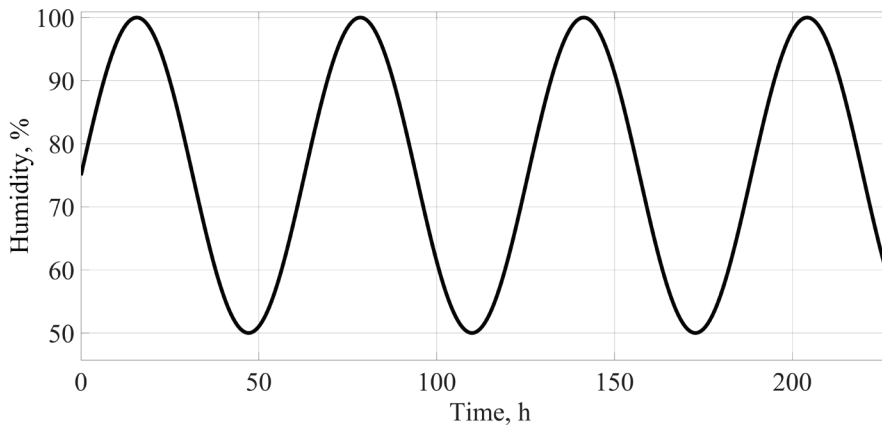

Fig. 8. Chart of changes in outdoor humidity from 50 % to 100 %

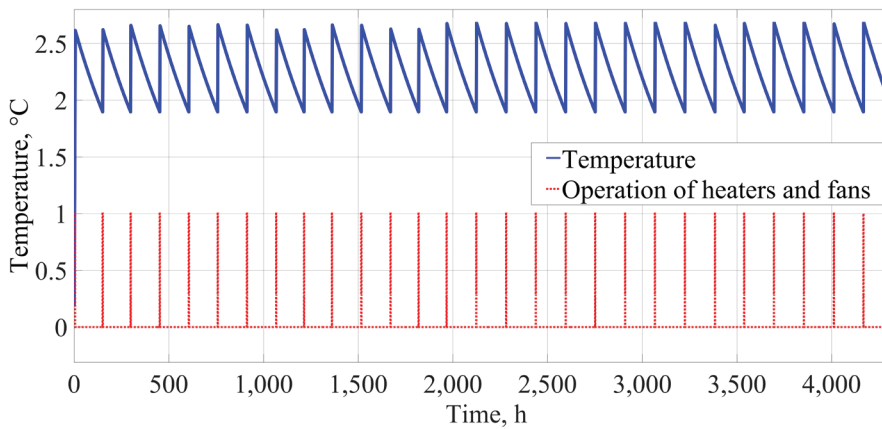

Fig. 9. Results of maintaining the pre-set temperature of a vegetable storage facility

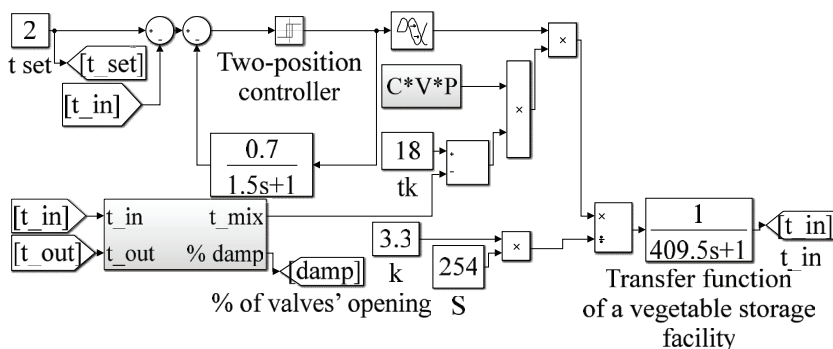

Fig. 10. Schematic showing the mathematical model of a vegetable storage facility with a first-order aperiodic link

Then, depending on the value of coefficients T, k for the temperature of the outdoor air and humidity, changing by characteristics (Fig. 7, 8), the air temperature in a vegetable storage facility t_{in} was obtained (Fig. 11).

According to the results of modeling, we obtained the coefficients of the aperiodic link $T=1.5, k=0.7$ (Fig. 12), according to the results of which the value of the maximum error of control and the period of self-oscillations was plus $0.15\text{ }^{\circ}\text{C}$ and 112 h.

Humidity maintenance at the level of 75 % due to switched-on ceiling fans is shown in Fig. 13.

The obtained results of maintaining the pre-set humidity in a vegetable storage facility meet the requirements for the product quality shown in chapter 4.2, point 7.

Table 5 gives the total time of switched-on channel heaters and fans during modeling time.

Table 5

Total time of heater's operation

Method of control	Time of heater's operation, h	Ratio of heater operating time to total modeling time, %
Two-position control with hysteresis that equals to plus $0.3\text{ }^{\circ}\text{C}$	48.44	1.11
Two-position control with hysteresis that equals to plus $0.3\text{ }^{\circ}\text{C}$ and aperiodic link	35.1	0.8125

Results from Table 5 show that adding the aperiodic link to the two-position controller with hysteresis decreased the operation time of the heating element.

In 2021, the cost of 1 kW of electricity is UAH 1.68, or USD 0.0596 (at the exchange rate of UAH to USD of 28.2 to 1).

Based on the total operating time of the heater, the heater power equal to 3.0 kW, the fan power equal to 1.5 kW at the efficiency of 10,000 m^3/h , the cost of electricity, the heating costs of the vegetable storage facility are given in Table 6.

The resulting calculations from Table 6 show a 13 % reduction in the total operating time of controlling elements and the costs of operation of controlling elements.

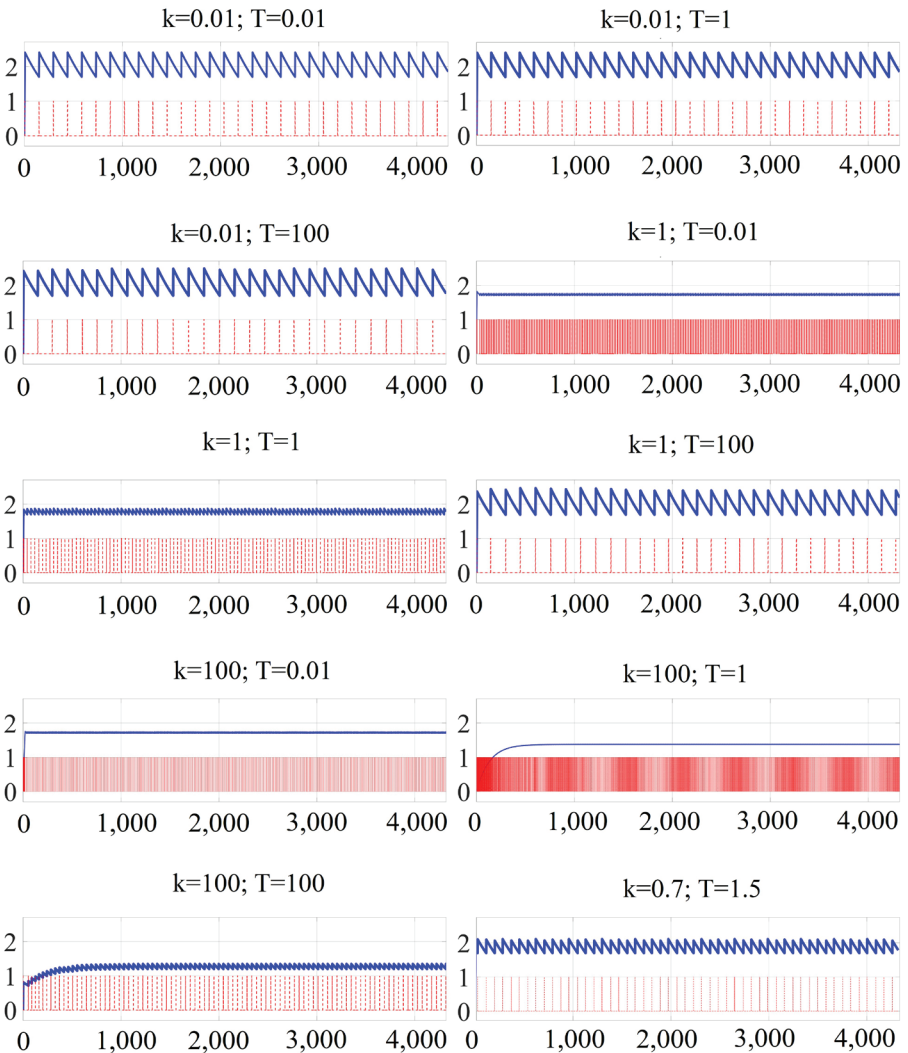

Fig. 11. Results of maintaining the pre-set temperature of a vegetable storage facility, depending on a change in coefficients k and T

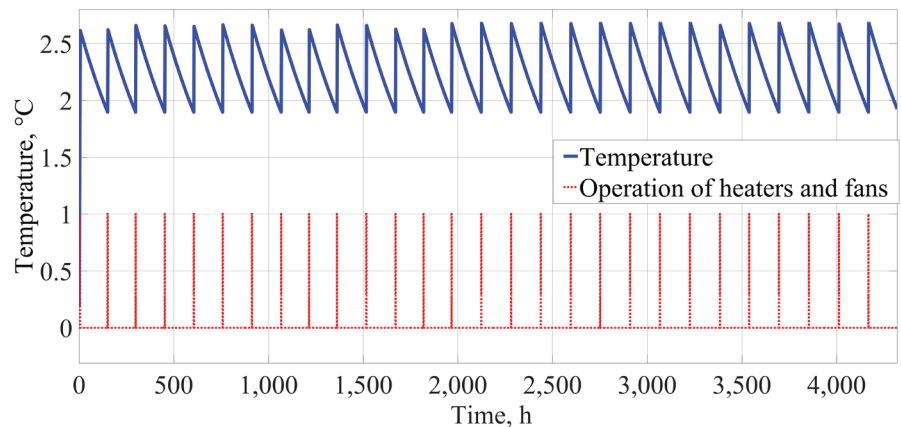

Fig. 12. Results of maintaining the pre-set temperature of a vegetable storage facility

Table 6

Heating costs of a vegetable storage facility

Method of control	Operation time of a heater and a fan, h	Cost, USD
Two-position control with a hysteresis of plus $0.3\text{ }^{\circ}\text{C}$	48.44	12.98
Two-position control with a hysteresis of plus $0.3\text{ }^{\circ}\text{C}$ and aperiodic link	42.15	11.29

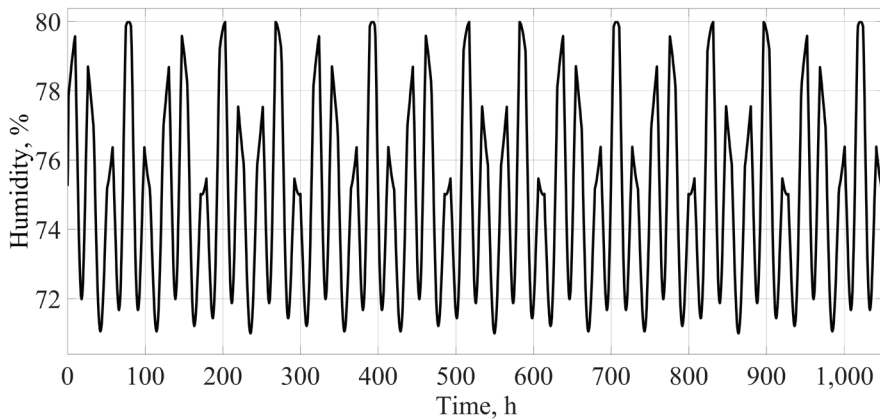

Fig. 13. Chart of maintaining the pre-set humidity in a vegetable storage facility

6. Discussion of results of using the aperiodic link in the feedback chain of the two-position temperature controller at a vegetable storage facility

To compare the effectiveness of using the aperiodic link in the operation of the two-position controller, the following criterion was used: accuracy of measurements – the maximum deviation of the actual temperature value from the pre-set ones. The maximum deviation was calculated in absolute value (°C) and the value was reduced to the assigned range (%).

The results obtained in the article are compared with the following methods for temperature control: the mathematical model of storage of agricultural products in the refrigerator [2], the mathematical model of the two-position controller [4], the self-adaptive fuzzy PID controller [18].

Table 7 gives the results of the maximum control error.

Table 7

Maximum control error

Method of control	$\Delta_{max}, ^\circ C$	$\delta_{max}, \%$
Two-position control with hysteresis plus 0.3 °C	0.55	27.5
Two-position control with hysteresis plus 0.3 °C and the aperiodic link	0.15	7.5
Computer model of storage of vegetable produce in a refrigerator [2]	0.3	7.5
Mathematical model of the two-position controller [4]	0.25	5
Self-adapting fuzzy PID controller [18]	1	5

Results in Table 7 show that the addition of an aperiodic link reduced the maximum value of the static error of control from 0.55 °C to 0.15 °C. Compared to other methods, the developed algorithm showed higher accuracy of maintaining temperature in absolute value.

The main limitation for the widespread use of the existing methods [2, 4, 18, 20, 21] is the relatively high costs of their development and implementation. The developed model of a vegetable storage facility takes into consideration the peculiarities of this type of object due to the inclusion of information about the current state and quantity of the product in the transfer function, unlike in [2]. Thus, the requirements for the models of vegetable storage facilities and fruit storage facilities [5] are met.

Unlike [14], in this study modeling was carried out in the time interval equal to the product storage time. This

time significantly exceeds the time that was selected in publications [2, 4, 18–21] and makes it possible to calculate the operation time of controlling elements and the economic effect of the implementation of the proposed method. The results shown in Table 6 demonstrate a decrease in the operation time of the controlling elements, which meets the requirements for energy saving [5].

The proposed method is recommended to be used in the areas where a two-position controller is used and the object is inertial, but there are no restrictions for the oscillations in the control process.

One of the unresolved tasks in this work is the selection of the location of the product temperature sensors. In a bulk-type vegetable storage facility, the entire area is divided into uniform areas, each of which has a temperature sensor. Temperature is controlled according to the average values of temperature sensors. Under actual conditions, the product can get rotten in each separate section, which is accompanied by an increase in temperature in this area. Such an increase in temperature also affects the average value of control. That is why the task is to determine such abnormal zones and exclude them from the average calculation value.

A vegetable storage facility should be also considered as a power-consuming site with distributed parameters, and the temperature should be maintained in separate areas, rather than by the average value. That is why in further studies, it is planned to construct a model of a vegetable storage facility as a site with distributed parameters and to apply the obtained results to vegetable storage facilities with a container type of storage. It is also planned to model other modes of product storage: drying, curing, cooling, heating.

Implementation of results of theoretical and applied research can reduce the costs of developing and upgrading temperature control methods and of equipment operation. The proposed results can be used when growing vegetables and mushrooms on greenhouses and mushroom farms, product storage in refrigeration chambers.

7. Conclusions

1. The model of a vegetable storage facility was constructed in the MATLAB Simulink programming environment (USA) based on the data on the dimensions of a vegetable storage facility, equipment involved in maintaining the temperature and humidity mode, and the resulting equation of thermal balance. This model applied an algorithm for controlling the temperature field with the use of two-position control with the addition of an aperiodic link to the feedback circuit. The addition of this link showed the effectiveness of the controller in reducing the maximum error of control and the period of self-oscillations compared to the existing method of two-position control.

2. The mathematical model of the controller was constructed based on the factors affecting temperature and humidity in a vegetable storage facility and the principle of operation of controlling elements. This model makes it pos-

sible to obtain the necessary adjustment coefficients k and T for the aperiodic link with its further use in the control of the temperature in a vegetable storage facility.

3. The operation of the two-position controller to maintain the pre-set temperature and humidity in the mode of vegetable storage, which lasts 180 days, was modeled. The maximum absolute error of temperature control was $0.5\text{ }^{\circ}\text{C}$

for the controller without feedback, which is used in most vegetable storage facilities. The results of modeling proved the possibility of reducing the maximum absolute error of control up to $0.15\text{ }^{\circ}\text{C}$ by adding an aperiodic link to the feedback circuit of the controller. Modeling results also showed a 13 % decrease in the total operation time of controlling devices.

References

- Admaev, A. I. (2018). Sistema kontrolya i upravleniya mikroklimatom v ovoschehranilische. Informatsionnye tehnologii i upravlenie. Materialy 54-y nauch. konf. aspirantov, magistrantov i studentov. Minsk, 24–25. Available at: https://libeldoc.bsuir.by/bitstream/123456789/32801/1/Admayev_Sistema.pdf
- Akdemir, S., Bartzanas, T. (2015). Numerical Modelling and Experimental Validation of a Cold Store Ambient Factors. *Journal of agricultural sciences*, 21, 606–619. doi: https://doi.org/10.1501/tarimbil_0000001361
- Nemenushaya, L. A., Stepanischeva, N. M., Solomatin, D. M. (2009). Sovremennye tehnologii hraneniya i pererabotki plodoovoschnoy produktsii. Moscow: FGNU «Rosinformagroteh», 172. Available at: <https://rosinformagrotech.ru/data/itpk/kartofel-i-ovoshchi/send/18-kartofel-i-ovoshchi/469-sovremennye-tekhnologii-khraneniya-i-pererabotki-plodoovoschnoj-produktsii>
- Meneghetti, C. R., Tizzei, A., Cappelli, N. L., Umezu, C. K., Bezzon, G. (2013). A Mathematical model for the cold storage of agricultural products. *Revista Ciència Agronômica*, 44 (2), 286–293. doi: <https://doi.org/10.1590/s1806-66902013000200010>
- Malanchuk, Y., Khrystyuk, A., Sych, V. (2020). Problems of automation of fresh fruits and vegetables storage processes. *Modeling, Control and Information Technologies*, 4, 92–95. doi: <https://doi.org/10.31713/mcit.2020.34>
- Maltsev, S. V., Kluev, S. I., Pshechenkov, K. A. (2017). The microclimate control system in modern potato storage facilities. *Zaschita kartofelya*, 2, 12–17. Available at: http://www.kartofel.org/zakart/2_2017.pdf
- Yermilova, N., Kyslytsia, S., Tarasiuk, R. (2019). Development of automated control system for equipment of a vegetable storage facility based on neuro-fuzzy systems. *Control, Navigation and Communication Systems*, 1 (53), 50–54. doi: <https://doi.org/10.26906/sunz.2019.1.050>
- Tolsma. Available at: <https://tolsma.com.ua/>
- Mooij Agro. Available at: <https://www.mooij-agro.com/en/>
- Lekomtsev, P. L., Dresviannikova, E. V., Niazov, A. M., Orlov, S. V. (2017). Mathematical modeling of refrigeration using vortex tubes in vegetable stores. *Engineering Journal of Don*, 4. Available at: http://www.ivdon.ru/uploads/article/pdf/IVD_109_Lekomcev.pdf_24bf077381.pdf
- Timoshenko, V. A., Sutulo, A. V., Dovgan', N. B. (2017). Metody viyavleniya porokov kartofelya pri razlichnyh temperaturnyh rezhimah hraneniya i otsenka ego kachestva. *The Electronic Scientific Journal*, 5-1, 16–19. Available at: <http://co2b.ru/docs/enj.2017.05.01.pdf>
- Uzakov, G. N. (2010). Snizhenie zatrat energii v teplohladosnabzhenii kombinirovannogo sooruzheniya «ovoschehranilische-gelioteplytsa» s ispol'zovaniem teplovyh nasosov. *Molodoy ucheniy*, 1 (11), 73–78. Available at: <https://moluch.ru/archive/22/2218/>
- Alhamdan, A., Alsadon, A., Wahb-Allah, M. A., Nagar, M. E. (2011). Influence of Storage Conditions on Seed Quality and Longevity of Four Vegetable Crops. *American-Eurasian Journal of Agricultural & Environmental Sciences*, 11 (3), 353–359. Available at: [https://www.idosi.org/aejaes/jaes11\(3\)11/8.pdf](https://www.idosi.org/aejaes/jaes11(3)11/8.pdf)
- Tervonen, J. (2018). Experiment of the quality control of vegetable storage based on the Internet-of-Things. *Procedia Computer Science*, 130, 440–447. doi: <https://doi.org/10.1016/j.procs.2018.04.065>
- Zhukov, A. D., Ter-Zakaryan, K. A., Tuchaeu, D. U., Petrovsky, E. S. (2018). Energy-efficient insulation of food storage rooms and vegetable stores. *International Agricultural Journal*, 1, 65–67. doi: <https://doi.org/10.24411/2587-6740-2018-11015>
- Iacomi, C., Roşca, I., Madjar, R., Iacomi, B., Popescu, V., V rzaru, G., Sfetcu, C. (2014). Automation and computer-based technology for small vegetable farm holders. *Scientific Papers. Series A. Agronomy*, 57, 415–420. Available at: <http://agronomyjournal.usamv.ro/pdf/2014/art74.pdf>
- Kachanov, P., Yevseienko, O. (2017). Modeling of daily temperature mode in premises using a predictive controller. *Eastern-European Journal of Enterprise Technologies*, 4 (2 (88)), 33–41. doi: <https://doi.org/10.15587/1729-4061.2017.108574>
- Kun, T., Peng, X., Hong-kun, H. (2015). The application of Self-adaptive Fuzzy PID control the evaporator superheat. *International Journal of Research in Engineering and Science (IJRES)*, 3 (42), 64–71. Available at: <https://1library.net/document/ydv4xkky-application-self-adaptive-fuzzy-pid-control-evaporator-superheat.html>
- Grudinin, V. S., Khoroshavin, V. S., Zotov, A. V., Grudinin, S. V. (2019). Adaptive Iterative Control of Temperature in Greenhouse. *Engineering Technologies and Systems*, 29 (3), 383–395. doi: <https://doi.org/10.15507/2658-4123.029.201903.383-395>
- Tizzei, A., Meneghetti, C. R., Cappelli, N. L., Umezu, C. K. (2011). System for studies of control strategies applied in the refrigerated chambers. *Engenharia Agrícola*, 31 (5), 868–878. doi: <https://doi.org/10.1590/s0100-69162011000500004>
- Morimoto, T., Islam, M. P., Hatou, K. (2013). An Intelligent Control Technique for Dynamic Optimization of Temperature during Fruit Storage Process. *American Journal of Operations Research*, 03 (01), 207–216. doi: <https://doi.org/10.4236/ajor.2013.31a020>