

Existing technical means for loading silos with grain material do not fully meet the needs of production. The issue related to grain injury remains urgent, which predetermines the need to design a gravitational loader of another principle of operation with the appropriate theoretical justification for the movement of grain material in it. This paper has presented and substantiated the model of the gravitational movement of grain in the peripheral open screw channel with two variable angles of inclination. The model is based on the system of forces in the cylindrical coordinate system, acting on the volume of grain flow in the peripheral screw channel. The grain speed at the end of the braking section of the channel should be as low as possible but not less than the initial flow rate at the beginning of the acceleration section. The model takes into consideration this condition and ensures the optimal passage of grain along any part of the channel.

The reported model makes it possible to obtain the speed of grain movement at any time, takes into consideration the height of the bunker hole and the dependence between the angles of inclination of the spirals of acceleration and brake sections. A mathematical dependence is given for these angles that ensures the passage of grain without its discharge and, at the same time, prevents injury to the grain mass due to a controlled decrease in the resulting speed. A separate dependence is provided to find the time at which the grain increases its speed on the acceleration section, reaching the maximum value.

Based on the model, a peripheral open screw channel with two angles of inclination of spirals α and β has been proposed. For this channel, the relationships between its key parameters have been established, in particular, values have been substantiated for the recommended angles of $41^\circ \dots 45^\circ$ for the acceleration section and $39^\circ \dots 35^\circ$ for the brake section, respectively, as well as the h_0/r ratio not less than $0.6 \dots 0.7$

Keywords: grain movement speed, screw channel, variable angles of inclination, injury

UDC 531.1:633.1:691.88

DOI: 10.15587/1729-4061.2021.235451

BUILDING AN ANALYTICAL MODEL OF THE GRAVITATIONAL GRAIN MOVEMENT IN AN OPEN SCREW CHANNEL WITH VARIABLE INCLINATION ANGLES

Volodymyr Arendarenko

PhD, Associate Professor*

Anatolii Antonets

PhD, Associate Professor

Department of General Technical Disciplines**

Oleg Ivanov

Corresponding author

PhD, Associate Professor*

E-mail: oleegivanov@yahoo.com

Ihor Dudnikov

PhD, Associate Professor

Department of Sectoral Mechanical Engineering**

Tetiana Samoylenko

Engineer

Company «Tayfun»

Yevropeiska str., 66, Poltava, Ukraine, 36002

*Department of Technologies and Equipment

of Processing And Food Productions**

**Poltava State Agrarian Academy

H. Skovorody str., 1/3, Poltava, Ukraine, 36003

Received date 14.04.2021

Accepted date 24.05.2021

Published date 30.06.2021

How to Cite: Arendarenko, V., Antonets, A., Ivanov, O., Dudnikov, I., Samoylenko, T. (2021). Building an analytical model of the gravitational grain movement in an open screw channel with variable inclination angles. *Eastern-European Journal of Enterprise Technologies*, 3 (7 (111)), 100–112. doi: <https://doi.org/10.15587/1729-4061.2021.235451>

1. Introduction

An important issue related to modern agriculture is the increase in the gross production of high-quality grain. The overall food security of each country depends on its quantity and quality, and it is the key to the sustainable development of production entities in the processing and food industry [1].

To preserve the grain, modern elevators are equipped with metal silos on a concrete foundation. Their height is limited by the carrying capacity of cargoes and does not exceed 30–60 m. Silos are typically built to increase the capacity of an enterprise and save on land. Silo walls are made of corrugated zinc steel, which improves the strength of the structure and reduces its weight. Grain silos are loaded with scraper conveyors, which are located in the upper transport galleries. These conveyors feed grain cargo to the loading holes of silos.

With an increase in the distance from the main elevator structure to silos, the intensity of interaction between grain and the working bodies of scraper conveyors increases and, as a result, the number and magnitude of injuries also increase. Therefore, grain cargo, which is transported to the loading holes of silos, may contain a certain percentage of already injured grain.

Once in the loading hole, the grain under the action of gravity freely falls to the bottom of the silo. Grain cargo, which falls from the top of the silo, is not a bound medium, so it can be considered as the vertical movement of individual grains. Grains falling from a considerable height hit the walls and concrete bottom of the silo and are injured. Gravitational loading of silos is also accompanied by a blow of grain to the grain embankment. The shock interaction of the damaged and not damaged grain in the middle of the silo increases

the amount of injured grain. Very often, with such blows, the main part of the grain is damaged – the embryo.

It is well known that the injured grain is less resistant to storage, and the injuries obtained during loading serve as a center for the evolution of harmful bacteria and microbes.

The above-specified issues related to the storage and transportation of grain mass render relevance to the task of careful loading of grains into silos and necessitate finding ways to control the speed of grain movement for its gravitational loading without injury. To comprehensively solve the task of careful loading of grain into silos, it is advisable to design and investigate the operation of the peripheral open screw channel with variable angles of inclination of the acceleration and braking sections. This, in turn, requires the construction of an appropriate physical and mathematical model of grain movement at the surface of a given screw channel.

2. Literature review and problem statement

During the gravitational loading of grain into a silo, there is an uncontrolled increase in the rate of fall of grain mass and there are numerous force interactions of the shock type with the silos' structural elements. These impact collisions cause violation of the integrity of the grain with the evolution of microcracks, surface chips, layering into separate components, and other negative consequences, which ultimately lead to a decrease in grain quality [2, 3].

Resolving the specified task requires the design and implementation of technical solutions and tools that could adjust the high-speed movement of grain, its concentration within a certain volume, and controlled supply. Such studies were started in work [4], which established the connection between the angles of the sections of the discharge straight channel and provided a functional dependence between them for rectilinear movements. Paper [5] considered a screw channel, which has only an acceleration section with a variable angle of inclination of the spirals, which does not make it possible to reduce the speed of movement of grain.

A separate solution to the issue of injury is the use of cone-type loading devices [6], namely consistently combined cone guides located along the line of gravitational movement of grain. However, the widespread implementation of this solution faces cumbersome structural implementation and a decrease in the usable internal space of the silo. The movement of grain over such guides is characterized by shock interaction, which somewhat compromises the solution to the problem of injury to seeds.

As a result of post-harvest processing and grain loading, 30–40 % of the seeds have micro-damage [7, 8]. The description of technical solutions for uniform loading of grain, which reduces its injury, is given in works [9, 10] but does not eliminate it completely because there is no reduction in the speed of grain movement.

Grain transportation is carried out with the involvement of mechanical conveyors with working bodies of various types: scrapers, screws, chains, plates, ladles [11, 12]. These transporters prevent the development of excessive speeds but do not solve the issue of injury. The interaction of the working bodies of conveyors with grain causes its intensive mixing and wear due to the interaction with surrounding surfaces. In particular, when using one noria, the injury rate can reach 2–5.6 % [13], in the technological chain there may be several such norias, so the level of damage is quite significant. Often,

these transportation devices are used only to deliver grain to the loading nozzle of the silo, from where it freely falls to the bottom of the silo, receiving inevitable damage. At the same time, an increase in the height of the grain fall by 3 times leads to an increase in the number of damaged grains by more than 8 times [14].

The injured grain has a greater breathing intensity, which is another negative consequence from an uncontrolled speed of its loading. This figure is 1.8 times higher than the value of non-injured grain [10]. Due to intensive breathing, significant release of heat and moisture occurs, which leads to damage or complete death of seeds. At the same time, under the action of rapid gravitational loading, such an injured mass in the lower layers is more compacted, which negatively affects the strength of the grain [15], causing its lying down and deformation [16].

When loading silos with a compact fast jet, segregation of the grain embankment is observed. The effect of segregation on the quality of grain products is usually negative. Papers [17, 18] summarized results on the rapid gravitational flows of grainy materials in trays, channels, and inclined planes, while aspects of segregation and grain injury reduction remained unattended. At the same time, works [19, 20] state that the gravitational flows of grainy materials are accompanied by segregation effects but they do not consider ways to overcome this problem.

In practice, special devices are often used to reduce injury to grain when loading it: bulk shelves are installed in a telescopic pipe, concentric rings with vertically placed blades, vertical screw conveyors with windows, fixed grooves [21]. Hollow cut cones are also widespread as gravitational distributors under the loading neck of a silo [22, 23]. The structures proposed in [21–23] reduce grain injury and dynamic bulk compaction but are cumbersome and do not solve the issue of controlled reduction of grain movement speed when loading it into silos.

Another way to load silos is to use vertical screw conveyors. Theoretical studies into grain movement at the screw surface are reported in works [23, 24]. Such movement ensures careful loading of the container with grain. The disadvantage of this technique is the presence in the middle of the tank of a bulky cascading structure and the absence of a separate braking section, which does not make it possible to reduce the speed of grain movement.

The option to overcome the problem without impact loading of silos with the grain is to design various cascading devices that reduce the height of the free fall of grain to the bottom of the tank. The process of movement of grain material in cascading gravitational separators is described in [25]. Papers [26, 27] report the results of theoretical studies into this gravitational movement of grain on different working bodies. Such movement has a high speed and is accompanied by the active interaction of particles with each other and the working body, and this negatively affects the process of grain loading and its long-term storage. It should also be noted that the cascading technique of grain loading is characterized by significant spatial heterogeneity [28, 29]. This heterogeneity causes in the central part of the grain layer the greatest concentration of the solid phase and the increased content of coarse and dense grains. At the same time, at the peripheral parts of the flow, which are characterized by an increased space between the grain space, there is a higher concentration of light particles.

Special attention of scientists is paid to the issue related to building the physical and mathematical models of grain

movement. In particular, studies [30, 31] examine the movement of spherical particles on the surfaces of agricultural machines, and the movement of grain on the movable surfaces of sowing machines, respectively. Specifically, paper [30] gives the dependences to determine the location of grain but not the speed of its movement. Work [31] reports analytical dependences to determine the trajectory of grains on the surface of the disk and the speed of rotation of the seed array but does not take into consideration its deviations from the proper conical shape. Studies [32, 33] give the mathematical models of grain movement in the airflow and in the cylindrical rotating sieve. In particular, work [32] constructed a mathematical model of the movement of a combed heap particle, which establishes the relationship between the speed of movement of the particle and the speed of an airflow, albeit implicitly. That greatly complicates obtaining actual speed and requires additional mechanical-mathematical research. At the same time, a model in [33] is represented by differential equations describing the movement of heap in a cylindrical sieve, which rotates around the axis at an angle to the horizon. The model is represented by a separate rotational and translational component of movement in the implicit form and is designed primarily to identify effective modes of operation for grain cleaning. The above physical and mathematical models are aimed mainly at solving the tasks of cleaning and processing grain mass. The models do not make it possible to control the speed of movement of grain, in particular, do not describe its gravitational movement in a spiral with two variable angles of inclination for the acceleration and braking sections.

Thus, despite a significant body of research into the issues related to the grain injury during its processing, transportation, and loading into a silo, the problem remains to be solved. Existing technical means for loading silos with grain material, as well as available theoretical physical and mathematical models and practical studies, do not fully meet the needs of production. Specifically, in the above-specified devices, methods, and approaches of scientists, the issue of the regulation, control, and reduction in the speed of grain movement during the operation of its loading into silos is not addressed in detail. The problem of bulkiness of the structures also remains urgent. That, in turn, predetermines the need to devise a gravitational loader with a different principle of operation involving an appropriate theoretical justification for the movement of grain material in it.

3. The aim and objectives of the study

The purpose of this work is to build a model of the gravitational movement of grain in an open

screw channel with two variable angles of inclination. This could improve the technology of loading silos with grain material without injury.

- To achieve the set aim, the following tasks have been solved:
- to substantiate the form and structure of a theoretical model of the gravitational movement of grain in an open screw channel;
 - to find the ratio between the angles of inclination of the acceleration and braking sections;
 - to investigate the parameters of the analytical model of the gravitational movement of grain in the open screw channel with different angles of inclination of the discharge sections;
 - to suggest, based on the theoretical study, a technical description of the peripheral open screw channel with different angles of inclination of the acceleration and braking sections;
 - to represent the results of the experimental study and compare them with the estimation theoretical data on the examined model.

4. The study materials and methods

4.1. A system of forces acting on the elementary volume of a grain flow in an open screw channel

We studied the grain movement speed in an open screw channel with acceleration and braking sections with corresponding variable angles of inclination. This model is based on the system of forces acting on the elementary volume of a grain flow in the screw channel, in the cylindrical coordinate system (Fig. 1).

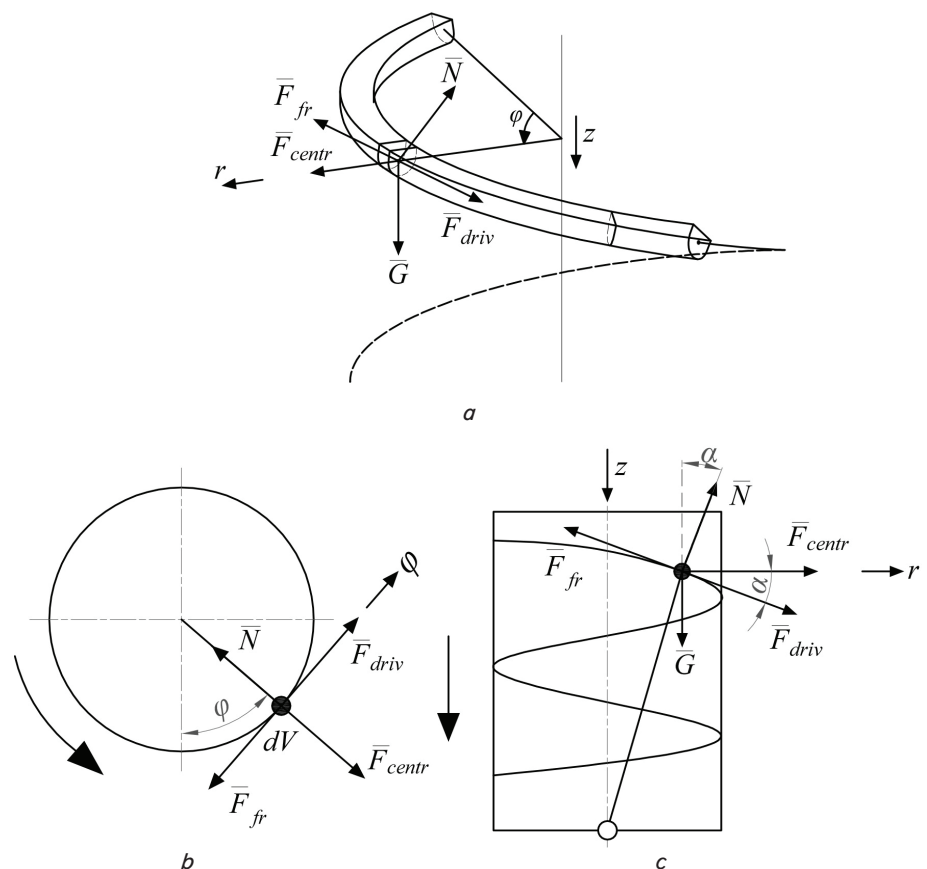

Fig. 1. The system of forces acting on the elementary volume of a grain flow in the screw channel, in the cylindrical coordinate system: a – in the spatial representation; b – in the horizontal representation; c – in the vertical representation

The gravitational movement of grain mass through the screw channel occurs under the influence of the driving force $\vec{F}_{driv} = m\vec{a}$, determined from the balance of forces acting on the specified moving mass:

$$\vec{F}_{driv} = \sum \vec{F}_k \text{ or } m\vec{a} = \sum \vec{F}_k, \quad (1)$$

where $\sum \vec{F}_k$ is the sum of all forces acting on a separate mass of the grain flow in a screw channel.

Taking into consideration the rotational and translational nature of grain movement in a screw channel, the balance of forces in the vector form takes the following form:

$$m\vec{a} = \vec{F}_{fr} + \vec{F}_{centr} + \vec{N} + \vec{G}, \quad (2)$$

where \vec{F}_{fr} is the friction force of a grain flow against the surface of a screw channel; \vec{F}_{centr} is the centrifugal force acting on a grain flow during the rotational movement of a grain flow around the central axis of a screw channel; \vec{N} is the force of the normal response of the surface of a screw channel; \vec{G} is the gravitational force.

When mapping all the components onto the appropriate directions of the cylindrical coordinate system, the balance of forces can be represented in the form of the following system of representation forces:

$$\begin{cases} ma_r = F_{centr}^r - N^r, \\ ma_\phi = -F_{fr}^\phi + N^\phi, \\ ma_z = -F_{fr}^z - N^z + G^z, \end{cases} \quad (3)$$

where a_r, a_ϕ, a_z are the representations of the acceleration of grain mass m in the radial, angular, and height directions of the cylindrical coordinate system; F_{centr}^r, N^r are the representations of the centrifugal force and normal force of support response in the radial direction; F_{fr}^ϕ, N^ϕ are the representations of the friction force and the normal force of support response in the angular direction; F_{fr}^z, N^z, G^z are the representations of the friction force and the normal force of support response, and gravitational force in the height direction.

4. 2. The procedure and program of an experimental study into the grain movement speed in an open screw channel

The purpose of this experimental study is to determine the nature of changes in the kinematic parameters of grain movement dependent on impact factors and to compare them with those theoretically estimated. This would make it possible to determine the level of convergence of the obtained results and draw a conclusion about the adequacy and accuracy of the proposed analytical model.

The maximum and resulting speeds of grain movement were selected as the kinematic parameters to be analyzed.

In accordance with the goal of the experiments, a research program was formed including two stages.

At the first stage, the nature of change in the maximum speed of grain movement on the acceleration section was determined, depending on the geometrical parameters of this section. The number of factors that exert a direct impact on the formation of this criterion is quite significant, therefore, in order to reduce the number of experiments, only a few were subjected to variative changes. In particular, the angle of inclination of α of the acceleration section and the radius of the screw channel r were changed, provided that the number of turns n_p and the stability of the height of the fall of the grain h_0 were constant.

At the second stage, the resulting speed of grain discharged from the channel was studied. The study was carried out when changing the angle of inclination of the acceleration and braking sections, with other parameters fixed; the ratio that determines the relationship between the angles was maintained.

In order to obtain reliable data from each combination of variable factors at a level of significance of 5 %, it was planned to conduct five parallel experiments.

The results from the experimental study were treated according to the standard procedure for statistical data processing. Namely: checking for the homogeneity of the variances in the experiments according to the Cochran criterion, checking the normal distribution of the residual series according to the RS criterion, finding a relative error of residues and their statistical estimates, determining the coefficient of multiple correlations, comparing results from the experimental and theoretical studies by the size of relative errors between them. Such studies are the basis for assessing the accuracy and adequacy of the proposed model.

The procedure for conducting experiments implied a change in the geometry of the screw channel for the parameters selected for each stage and cyclic conducting of experiments at the required frequency and level of reproducibility.

Winter wheat grain with an average moisture content of 14 % was selected as grain material.

We tracked the time of movement of a grain flow (separately highlighted by the bright paint of its particles) through the screw channel during the experimental study using high-frequency video equipment. The frame analysis of the shot material has made it possible to determine the location of key grain flow particles in the screw channel and calculate the time duration of their movement. The size of the path and the duration of movement determined the speed of movement of grain.

5. Results of studying grain movement in the open screw channel with different angles of inclination of the descent sections

5. 1. The analytical notation of the gravitational movement of grain in an open screw channel

Representations of the acceleration vector \vec{a} in system (3) for each direction in the cylindrical coordinate system, taking into consideration the absence of grain mass movement in the radial direction, can be determined from the following expressions:

$$\begin{cases} a_r = 0, \\ a_\phi = r \cdot \frac{d^2\phi}{dt^2} + 2 \frac{dr}{dt} \frac{d\phi}{dt}, \\ a_z = \frac{d^2z}{dt^2}. \end{cases} \quad (4)$$

Since there is no movement of grain mass in the radial direction, the r coordinate takes a constant value, and the component dr/dt in the system of equations (4) is neutralized, so this system takes the following form:

$$\begin{cases} a_r = 0, \\ a_\phi = r \cdot \frac{d^2\phi}{dt^2}, \\ a_z = \frac{d^2z}{dt^2}. \end{cases} \quad (5)$$

Considering the zero radial acceleration $a_r=0$, the system of equations (3) is somewhat simplified:

$$\begin{cases} F_{centr}^r = N^r, \\ ma_\varphi = -F_{fr}^\varphi + N^\varphi, \\ mv_z = -F_{fr}^z - N^z + G^z. \end{cases} \quad (6)$$

The centrifugal force acting on the grain mass when it rotates around the axis of the screw channel is determined from the following expression:

$$F_{centr} = mr\omega^2, \quad (7)$$

where r is the distance from the axis of the screw channel to the center of weight of the grain mass; ω is the angular rotation speed of grain mass.

Friction force F_{fr} :

$$F_{fr} = \mu \cdot N, \quad (8)$$

where μ is the coefficient of grain friction against the surface of the screw channel, N is the force of the normal support reaction.

Considering dependences (7) and (8), the system of equations (6) takes the following form:

$$\begin{cases} N^r = mr\omega^2, \\ ma_\varphi = -\mu N^\varphi \cos \alpha + N^\varphi, \\ ma_z = -\mu N^z \sin \alpha - N^z + mg. \end{cases} \quad (9)$$

After selecting common multipliers and grouping them, system (9) takes the following form:

$$\begin{cases} N^r = mr\omega^2, \\ ma_\varphi = N^\varphi (1 - \mu \cos \alpha), \\ mv_z = mg - N^z (1 + \mu \sin \alpha). \end{cases} \quad (10)$$

The representations of the normal support response force N_φ and N_z can be found by mapping them onto the direction of gravitational force (Fig. 1):

$$\begin{cases} N_\varphi = G \sin \alpha, \\ N_z = G \cos \alpha, \end{cases} \text{ or } \begin{cases} N_\varphi = mg \sin \alpha, \\ N_z = mg \cos \alpha, \end{cases} \quad (11)$$

where α is the angle of inclination of the screw line on a certain section of the gravitational channel.

Taking into consideration expressions (11), system (10) takes the following form:

$$\begin{cases} N^r = mr\omega^2, \\ ma_\varphi = (1 - \mu \cos \alpha) \cdot mg \cdot \sin \alpha, \\ ma_z = mg - (1 + \mu \sin \alpha) \cdot mg \cdot \cos \alpha. \end{cases} \quad (12)$$

After reductions and trigonometric transformations, we obtain:

$$\begin{cases} N^r = mr\omega^2, \\ a_\varphi = g \cdot (\sin \alpha - 0.5\mu \sin 2\alpha), \\ a_z = g(1 - \cos \alpha - 0.5\mu \sin 2\alpha). \end{cases} \quad (13)$$

System (13) is formed as follows by replacing the acceleration representations a_φ and a_z with their expressions from the system of equations (5):

$$\begin{cases} N^r = mr\omega^2, \\ r \frac{d^2\varphi}{dt^2} = g(\sin \alpha - 0.5\mu \sin 2\alpha), \\ \frac{d^2z}{dt^2} = g(1 - \cos \alpha - 0.5\mu \sin 2\alpha). \end{cases} \quad (14)$$

Perform the following substitution:

$$\begin{aligned} K_1 &= \frac{1}{r} g(\sin \alpha - 0.5\mu \sin 2\alpha), \\ K_2 &= g(1 - \cos \alpha - 0.5\mu \sin 2\alpha). \end{aligned} \quad (15)$$

Thus, system (13) is brought to the following form:

$$\begin{cases} N^r = mr\omega^2, \\ \frac{d^2\varphi}{dt^2} = K_1, \\ \frac{d^2z}{dt^2} = K_2. \end{cases} \quad (16)$$

To find an analytical solution to the constructed system of differential equations, we shall conduct double integration:

$$\begin{cases} N^r = mr\omega^2, \\ \frac{d\varphi}{dt} = K_1 t + C_1, \\ \frac{dz}{dt} = K_2 t + C_3, \end{cases} \quad (17)$$

$$\begin{cases} N^r = mr\omega^2, \\ \varphi = 0.5K_1 t^2 + C_1 t + C_2, \\ z = 0.5K_2 t^2 + C_3 t + C_4. \end{cases} \quad (18)$$

The obtained integration constants C_1, C_2, C_3, C_4 can be found by setting the appropriate boundary conditions.

The total path that the grain mass traveled along the screw channel, taking into consideration the nature of change in the coordinates φ and z with respect to the system of equations (18), can be found from the following expression:

$$l = \sqrt{(r \cdot \varphi)^2 + z^2}. \quad (19)$$

The velocity V of the movement of grain mass, taking into consideration $V = d\ell/dt$, is determined as:

$$V = \frac{r^2 \varphi(t) \frac{d}{dt} \varphi(t) + z(t) \frac{d}{dt} z(t)}{\sqrt{r^2 (\varphi(t))^2 + (z(t))^2}}. \quad (20)$$

If the screw channel has a single angle of inclination α of the spiral, then the channel does not have a braking section and the grain mass constantly increases its speed. That is, according to (20), we obtain the speed of movement of grain for the acceleration section:

$$V = \frac{r^2 \varphi^p(t) \frac{d}{dt} \varphi^p(t) + z^p(t) \frac{d}{dt} z^p(t)}{\sqrt{r^2 (\varphi^p(t))^2 + (z^p(t))^2}}. \quad (21)$$

To prevent injury to the grain, it is necessary that the speed of movement of the grain mass should not increase significantly. To this end, the above screw installation (Fig. 1) should be improved and conditionally divided into the acceleration and braking sections, with the spirals' lengths l_{ac} and l_{br} and the angles of their inclination to the horizon α and β , respectively. That is, the grain speed at the end of the acceleration section would be the maximum V_{max} . At the same time, the resulting grain speed at the end of the braking section should be as low as possible but not less than the initial flow rate at the beginning of the acceleration section, that is, $V_{beg} \leq V_{end}$. The last condition ensures the passage of grain without its discharge on any part of the channel. To simplify further calculations, we shall assume that these speeds are equal, $V_{beg} = V_{end} = V_0$.

The initial speed V_0 is acquired by grain as a result of falling from the hole of the bunker, located at height h_0 from the edge of the acceleration section's channel. At the time of mass falling from the hole of the bunker to the initial edge of the channel, its potential energy is shifted to the kinetic energy, as a result of which the grain acquires the speed V_0 . According to the law of energy conservation $mgh_0 = mV_0^2/2$. Hence, the initial velocity of grain:

$$V_0 = \sqrt{2gh_0}. \quad (22)$$

Further study of the speed of grain movement requires finding a mathematical dependence between discretely variable angles of inclination α and β of the spirals of the screw channel to the horizon.

5.2. Finding a ratio between the angles of inclination of the acceleration and braking sections of the screw channel

To derive the ratio that would determine the mathematical dependence between the angles of inclination of the acceleration and braking sections α and β , in accordance with the condition $V_{beg} = V_{end} = V_0$, we shall apply the results of an earlier study [2] into straight acceleration and braking sections. In addition to the friction force, support response, and gravity, we shall also take into consideration the effect exerted on the grain by centrifugal force with the acceleration $a = V^2/r$ during its movement along the screw line. In accordance with the law of energy conservation, we shall build and solve a system of equations describing the transformation of the kinetic and potential energy of a grain flow on the acceleration and braking sections of the cylindrical spiral:

$$\begin{cases} mgh_0 = \frac{mV_0^2}{2}, \\ \frac{mV_0^2}{2} + mgl \sin \alpha - \mu m \left(g + \frac{V^2}{r} \right) l \cos \alpha = \frac{mV_{max}^2}{2}, \\ \frac{mV_{max}^2}{2} + mgl \sin \beta - \mu m \left(g + \frac{V^2}{r} \right) l \cos \beta = \frac{mV_0^2}{2}. \end{cases} \quad (23)$$

Equating the second and third equations of system (23) and simplifying the expression, we obtain:

$$\begin{aligned} & \frac{mV_0^2}{2} + mgl \sin \alpha - \mu m \left(g + \frac{V^2}{r} \right) l \cos \alpha + \\ & + mgl \sin \beta - \mu m \left(g + \frac{V^2}{r} \right) l \cos \beta = \frac{mV_0^2}{2}, \\ & mgl \sin \alpha - \mu m \left(g + \frac{V^2}{r} \right) l \cos \alpha + \\ & + mgl \sin \beta - \mu m \left(g + \frac{V^2}{r} \right) l \cos \beta = 0, \\ & l \sin \alpha - \mu \left(1 + \frac{V^2}{rg} \right) l \cos \alpha + \\ & + l \sin \beta - \mu \left(1 + \frac{V^2}{rg} \right) l \cos \beta = 0. \end{aligned} \quad (24)$$

To simplify further solution to (24), we shall adopt the lengths of the acceleration and braking sections to be the same, that is, $l_{ac} = l_{br}$:

$$\sin \alpha - \mu \left(1 + \frac{V^2}{rg} \right) \cos \alpha + \sin \beta - \mu \cos \beta = 0. \quad (25)$$

We obtain from equation (25):

$$\begin{aligned} & \sin \alpha + \sin \beta = \mu \left(1 + \frac{V^2}{rg} \right) \cos \alpha + \mu \left(1 + \frac{V^2}{rg} \right) \cos \beta, \\ & \sin \frac{\alpha + \beta}{2} = \mu \left(1 + \frac{V^2}{rg} \right) \cos \frac{\alpha + \beta}{2}, \\ & \beta = 2 \arctg \mu \left(1 + \frac{V^2}{rg} \right) - \alpha. \end{aligned} \quad (26)$$

To simplify (26), we assume the speed of grain V , which directly affects the centrifugal acceleration, to equal V_0 :

$$V = V_0 \rightarrow V^2 = V_0^2 = 2gh_0. \quad (27)$$

From (26), taking into consideration (27), we finally derive a dependence between the angles of the acceleration and braking sections:

$$\beta = 2 \arctg \mu \left(1 + \frac{2h_0}{r} \right) - \alpha. \quad (28)$$

5.3. Investigating parameters of the analytical model of the gravitational movement of grain in an open screw channel with different angles of inclination of descent sections

Taking into consideration (28), we write down the acceleration section coefficients (15) for the brake part of the spiral at an angle of inclination β :

$$K_1^{br} = \frac{1}{r} g (\sin \beta - 0.5 \mu \sin 2\beta),$$

$$K_2^{br} = g (1 - \cos \beta - 0.5 \mu \sin 2\beta),$$

or

$$K_1^{br} = \frac{1}{r} g \left(\begin{array}{l} \sin \left(2 \arctg \mu \left(1 + \frac{2h_0}{r} \right) - \alpha \right) - \\ - 0.5 \cdot \mu \sin 2 \left(2 \arctg \mu \left(1 + \frac{2h_0}{r} \right) - \alpha \right) \end{array} \right),$$

$$K_2^{br} = g \left(\begin{array}{l} 1 - \cos \left(2 \arctg \mu \left(1 + \frac{2h_0}{r} \right) - \alpha \right) - \\ - 0.5 \mu \sin 2 \left(2 \arctg \mu \left(1 + \frac{2h_0}{r} \right) - \alpha \right) \end{array} \right). \quad (29)$$

Taking into consideration (29), we shall rewrite system (18) for the braking section in the following form:

$$\begin{cases} N^r = mr\omega^2, \\ \varphi^{br} = 0.5K_1^{br}t^2 + C_1t + C_2, \\ z^{br} = 0.5K_2^{br}t^2 + C_3t + C_4. \end{cases} \quad (30)$$

Knowing (30) from (20), we obtain the grain mass velocity equation for the brake section of the screw channel:

$$v^{br} = \frac{r^2 \varphi^{br}(t) \frac{d}{dt} \varphi^{br}(t) + z^{br}(t) \frac{d}{dt} z^{br}(t)}{\sqrt{r^2 (\varphi^{br}(t))^2 + (z^{br}(t))^2}}. \quad (31)$$

For a further solution, we shall take into consideration the following facts:

- in the acceleration section, the grain speed increases from V_0 to V_{max} over a period of $[0; t_{ac}]$;
- in the braking section, the speed begins to decrease and, over a period $(t_{ac}; t_{max}]$ decreases to V_0 .

To derive an equation that would determine the instantaneous speed of grain movement at any given time in both sections, it is necessary to determine the time t_{ac} . During this time, the grain passes from the acceleration to the brake section, and the speed reaches the maximum value.

Knowing the step of the acceleration section of the screw line S , and the number of its turns n_{ac} with the angle of their inclination α , we first find the height h_{ac} of this section.

To this end, find the length of the turn and the length of the acceleration section l_{ac} in general:

$$S = \pi dtg\alpha = 2\pi rtg\alpha,$$

$$l_0 = \sqrt{(2\pi r)^2 + S^2} = \sqrt{4\pi^2 r^2 + (2\pi rtg\alpha)^2} = \sqrt{4\pi^2 r^2 + 4\pi^2 r^2 tg^2\alpha} = 2\pi r \sqrt{1 + tg^2\alpha},$$

$$l_p = n_p l_0 = n_p 2\pi r \sqrt{1 + tg^2\alpha}. \quad (32)$$

On the other hand, having determined the step of the screw spiral's turn, we obtain:

$$S = \frac{h_p}{n_p}, l_0 = \sqrt{(2\pi r)^2 + \left(\frac{h_p}{n_p}\right)^2} = \sqrt{4\pi^2 r^2 + \left(\frac{h_p}{n_p}\right)^2},$$

$$l_p = n_p l_0 = n_p \sqrt{4\pi^2 r^2 + \frac{h_p^2}{n_p^2}} = \sqrt{4\pi^2 r^2 n_p^2 + h_p^2}. \quad (33)$$

Find h_p by equating the right-hand parts of equations (32) and (33):

$$2n_p \pi r \sqrt{1 + tg^2\alpha} = \sqrt{4\pi^2 r^2 n_p^2 + h_p^2}, h_p = 2n_p \pi rtg\alpha.$$

Knowing h_{ac} , find the time of passing grain through the acceleration section t_{ac} , to this end, we shall use the equation $z(t)$ from system (18), by equating $z=h_{ac}$:

$$z = h_p = 0.5K_2 t^2 + C_3 t + C_4,$$

$$K_2 t^2 + 2C_3 t + 2C_4 - 2h_p = 0,$$

$$t_{1,2} = \frac{-2C_3 \pm 2\sqrt{C_3^2 - 2K_2(C_4 - h_p)}}{2K_2},$$

$$t_p = \frac{-C_3 + \sqrt{C_3^2 - 2K_2(C_4 - 2n_p \pi rtg\alpha)}}{K_2}. \quad (34)$$

The length of the channel spiral consists of the same lengths of the acceleration and braking sections. From (19), we find the total length of the screw spiral in accordance with these sections:

$$l = l_{ac} + l_{br} = \sqrt{(r \cdot \varphi)^2 + z^2} = \frac{1}{2} \sqrt{(r \cdot \varphi^{ac})^2 + (z^{ac})^2} + \frac{1}{2} \sqrt{(r \cdot \varphi^{br})^2 + (z^{br})^2}. \quad (35)$$

We shall write a generalized formula for moving speed $V = dl/dt$:

$$V = \left(\frac{1}{2} \sqrt{(r \cdot \varphi^{ac})^2 + (z^{ac})^2} + \frac{1}{2} \sqrt{(r \cdot \varphi^{br})^2 + (z^{br})^2} \right)'$$

Given the decrease in speed on the brake section of the screw spiral, we obtain:

$$V = \frac{r^2 \varphi^{ac}(t) \frac{d}{dt} \varphi^{ac}(t) + z^{ac}(t) \frac{d}{dt} z^{ac}(t)}{2\sqrt{r^2 (\varphi^{ac}(t))^2 + (z^{ac}(t))^2}} - \frac{r^2 \varphi^{br}(t) \frac{d}{dt} \varphi^{br}(t) + z^{br}(t) \frac{d}{dt} z^{br}(t)}{2\sqrt{r^2 (\varphi^{br}(t))^2 + (z^{br}(t))^2}}. \quad (36)$$

Adopting the equality of the lengths of the acceleration and braking sections $l_{ac}=l_{br}$, similarly to (32) to (34), we determine the number of turns of the brake section n_{br} , the time of its passage by grain t_{br} , and the time t_{max} :

$$n_{br} = \frac{l_{ac}}{2\pi r \sqrt{1 + tg^2\beta}}, \quad (37)$$

$$t_{br} = \frac{-C_3 + \sqrt{C_3^2 - 2K_2^{br}(C_4 - 2n_{br} \pi rtg\beta)}}{K_2^{br}}. \quad (38)$$

$$t_{max} = t_{ac} + t_{br}. \quad (39)$$

Taking into consideration ratios (18), (21), (22), (28) to (31), (34) to (39), we finally obtain the desired model of grain movement speed along the screw channel in the form of a system of equations:

$$V = \begin{cases} \sqrt{2gh_0}, & \text{at } t = 0, \\ \frac{r^2 \varphi^{ac}(t) \frac{d}{dt} \varphi^{ac}(t) + z^{ac}(t) \frac{d}{dt} z^{ac}(t)}{2\sqrt{r^2 \varphi^{ac}(t)^2 + (z^{ac}(t))^2}}, & \text{at } t \in (0; t_{ac}], \\ \frac{r^2 \varphi^{ac}(t_{ac}) \frac{d}{dt} \varphi^{ac}(t_{ac}) + z^{ac}(t_{ac}) \frac{d}{dt} z^{ac}(t_{ac})}{2\sqrt{r^2 \varphi^{ac}(t_{ac})^2 + (z^{ac}(t_{ac}))^2}}, \\ \frac{r^2 \varphi^{br}(t-t_{ac}) \frac{d}{dt} \varphi^{br}(t-t_{ac}) + z^{br}(t-t_{ac}) \frac{d}{dt} z^{br}(t-t_{ac})}{2\sqrt{r^2 (\varphi^{br}(t-t_{ac}))^2 + (z^{br}(t-t_{ac}))^2}}, & \text{at } t \in (t_{ac}; t_{max}), \\ \sqrt{2gh_0}, & \text{at } t = t_{max}. \end{cases} \quad (40)$$

The initial grain velocity at the beginning of the acceleration section in the second and third equations of model (40) is taken into consideration in (18) using the initial conditions $C_1...C_4$. Similar initial conditions for movement in the braking section are determined from (30) and depend on the maximum speed V_{max} , acquired by grain at the end of the acceleration section.

The above model determines the speed of grain movement at any time both on the acceleration and on the braking part of the screw channel with discretely variable two angles of inclination of the spirals.

5. 4. Technical description of the peripheral open screw channel with different angles of inclination of the acceleration and braking sections

The peripheral open screw channel (POSC) consists of the acceleration and screw brake sections, which are installed at different angles to the horizon. POSC is attached to the inner part of the silo with the ability to adjust the descent angles. As the silo is filled with grain, it is poured into the open screw channel.

The POSC silo (Fig. 2) consists of cylindrical container 1, loading hole 2, peripheral open screw channel 3 with discretely variable angles of inclination. Loading nozzle 2 directs grain material from the top of the silo to POSC. The body of screw channel 3 is formed by turning the U-shaped profile along the screw line with variable angles on acceleration 4 and brake 5 sections.

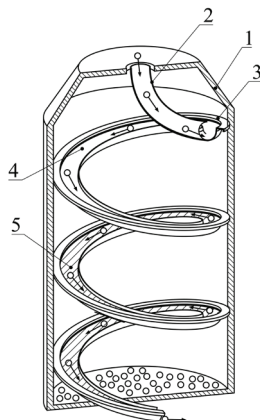

Fig. 2. Silo with peripheral open screw channel: 1 – cylindrical capacity; 2 – loading nozzle; 3 – peripheral open screw channel; 4 – acceleration section; 5 – brake section

The shown screw channel takes into consideration known theoretical and experimental studies by scientists and relies on the performed simulation of the gravitational movement of grain in a screw channel with a variable angle of inclination.

5. 5. Results of the experimental study and model analysis

The formation of the geometry of a screw channel, first of all, requires determining the angles of inclination of both sections of the channel.

Using dependence (28) between these angular parameters, a response surface was constructed (Fig. 3), illustrating the nature of the change in the angle of inclination of the braking section dependent on the angular parameter of the acceleration section and the ratio of the initial height h_0 of grain fall into the screw channel to the radius r of this channel.

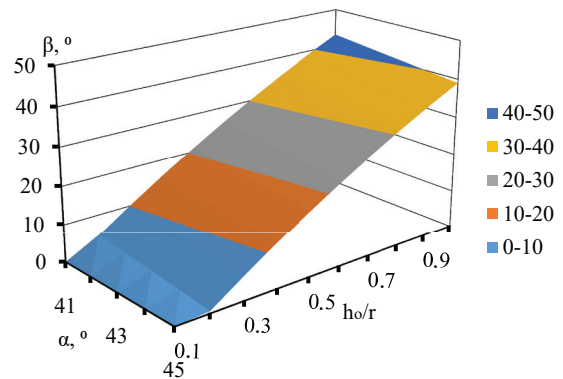

Fig. 3. The ratio of angles of the acceleration section, α , and the braking section, β , considering the ratio of h_0/r

Fig. 4 shows the results of the calculation of the required number of turns for the brake section n_{br} at an arbitrarily selected number of turns of the acceleration section n_{ac} . Calculations were carried out at a steady ratio $h_0/r=0.7$, the height of the screw channel of 1.5–2.5 m, and in the range of change of angle α from 41° to 45°.

In order to check the adequacy of the constructed model of grain flow movement along the screw channel and determine the degree of conformity of the movement parameters obtained from estimation to their equivalent values in real conditions of gravitational movement of grain, a series of experimental studies were carried out. The studies involved a laboratory sample of the peripheral open screw channel with different angles of inclination of the descent sections. The movement of grain flow in the screw channel during our theoretical and experimental studies was evaluated by several important kinematic parameters. These include the maximum acceleration speed and the resulting speed of the grain discharge from the screw channel.

As regards the discreteness of change in the influence factors, the following was taken for the first stage of our study: the height of the screw channel is 2 m; the h_0/r ratio was selected discretely (0.7, 0.8, 0.9); the number of turns $n_{br}=1$; the angle α changed from 41° to 45° in increments of 1°; the friction coefficient of grain material when moving along a metal channel was taken $\mu=0.3$.

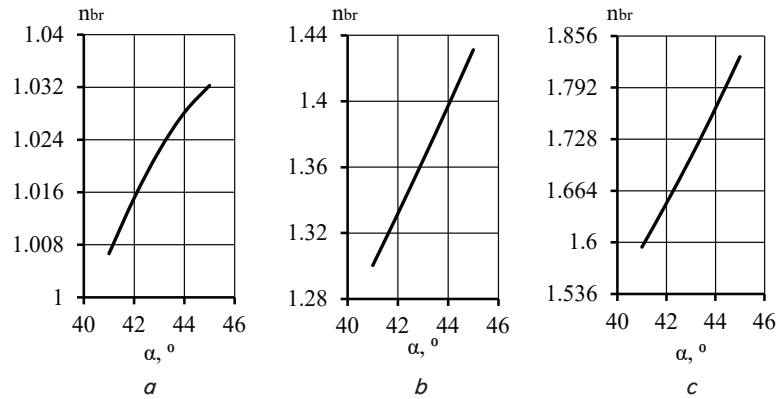

Fig. 4. The number of turns of the brake section depending on the angle α and n_{br} at $h_o/r=0.7$:
 a - $n_{br}=0.8$; b - $n_{br}=1$; c - $n_{br}=1.2$

Fig. 5 shows the nature of change in the maximum acceleration speed in the selected angle α change range; Table 1 gives, as an example, the results of comparing the results from our theoretical and experimental studies at $h_o/r=0.7$.

For the second stage of our study program, the impact factors acquired the same values as in the first stage at the $h_o/r=0.9$ ratio.

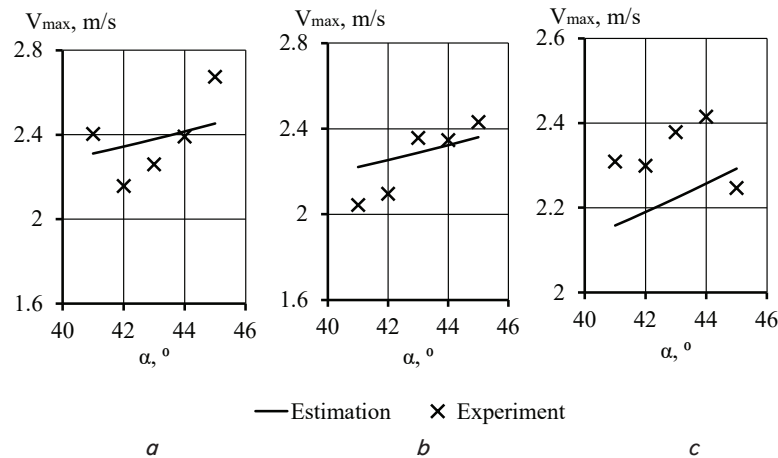

Fig. 5. Change in the maximum attainable speed of grain flow on the acceleration section depending on the angle α and the h_o/r ratio at $n_{br}=1$:
 a - $h_o/r=0.7$; b - $h_o/r=0.8$; c - $h_o/r=0.9$

The angle β , in this case, was calculated on the basis of the value of angle α from analytical expression (28) given in the theoretical section. The rule of five-fold repetition of the experiment for each variant of the angles' values was maintained at this stage. In this stage, the resulting speed of grain was studied (Fig. 6) at discharge from the channel.

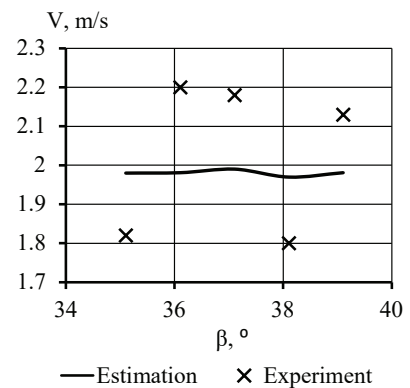

Fig. 6. Grain movement speed at the time of its descent from the screw channel

The results of our theoretical and experimental studies into determining the maximum and resulting speed of grain movement, and their corresponding statistical treatment, are given in Tables 1–3.

Table 1

Results of experiments on determining the maximum speed of movement on the acceleration section ($h_o/r=0.7$)

Angle α	Maximal speed V_{max} , m/s					Maximal speed V_{max} , average	Experiment variance D_i	Theoretical maximal speed V_{max} , m/s	Relative error, δ , %
41	2.39	2.40	2.47	2.32	2.43	2.40	0.0032	2.31063	4.0
42	2.10	2.08	2.00	2.30	2.31	2.16	0.0194	2.34355	7.9
43	2.21	2.31	2.36	2.17	2.24	2.26	0.0057	2.37837	5.1
44	2.39	2.26	2.47	2.48	2.34	2.39	0.0083	2.41493	1.1
45	2.69	2.81	2.56	2.62	2.68	2.67	0.0087	2.45312	8.9
Experimental error								0.09513	
Maximal variance, D_{max}								0.01944	
Variance total, ΣD								0.04525	
Cochran criterion observed value, G								0.42957	

Table 2

Results of experiments on determining the current rate of movement of grain at the time of its descent from the screw channel ($h_o/r=0.9$)

Angle α	Angle β	Resulting speed V_{end} , m/s					Resulting speed V_{end} , average	Experiment variance D_i	Theoretical resulting speed V_{end} , m/s	Relative error, δ , %
41	39	1.98	1.9	2.6	2.3	1.9	2.14	0.0945	1.980909	7.8
42	38	1.8	1.8	1.7	1.8	1.9	1.8	0.005	1.970000	8.6
43	37	2.1	2.2	2.2	2	2.4	2.18	0.022	1.990000	9.5
44	36	2.1	2.2	2	2.4	2.3	2.2	0.025	1.980909	11.1
45	35	1.7	1.7	1.8	1.8	2.1	1.82	0.027	1.980000	8.1
Experimental error								0.18627		
Maximal variance, D_{max}								0.09448		
Variance total, ΣD								0.17348		
Cochran criterion observed value, G								0.54462		

Table 3

The results of studying the values of the remaining experimental and theoretical data on the resulting speed of grain movement at the time of its descent from the channel

Residues V_{end} , m/s				
-0.01	0.080909	-0.61909	-0.31909	0.080909
0.180909	0.180909	0.280909	0.180909	0.080909
-0.11	-0.21	-0.21	-0.01	-0.41
-0.11909	-0.21909	-0.01909	-0.41909	-0.319091
0.28	0.28	0.18	0.18	-0.12
Relative errors, %				
0.505051	4.258362	23.8112	13.87353	4.25836
10.05049	10.05049	16.52405	10.05049	4.25836
5.238095	9.545455	9.545455	0.5	17.0833
5.671006	9.958687	0.954556	17.46213	13.8735
16.47059	16.47059	10	10	5.71429
Mean relative error, %			9.85	
Mathematical expectation			-0.05	
Variance			0.061	
Confidence interval			(-0.54; 0.451)	
Residual sum of squares			1.52643	
Normal distribution RS criterion			3.57 \in (3.34;4.53)	

6. Discussion of results of building a model of the gravitational movement of grain in the open screw channel with two variable angles of inclination

6.1. Discussion of the geometrical parameters of the screw channel and the kinematic parameters of grain movement based on the results of the theoretical study

The increase in speed at the top of the channel is due to the need to ensure the formation of grain accumulation on the acceleration section and not to pour it through the edges of the open grain channel. This combination provides for a significant increase in the speed of grain cargo on the first section of POSC. Acceleration section 4 in POSC (Fig. 2) should have the largest angle of inclination α to the horizon, and braking section 5, with an angle of inclination β , should be less than the angle α . Substantiation of the ratio of these angles follows from formulas (23) to (26) and (28).

Reducing the angle of inclination from α to β in the transition from one section of the channel to another makes it possible to significantly reduce the speed of gravitational descent. Speed reduction prevents the occurrence of critical

impact forces of grains against the wall and the concrete bottom of the silo, which, in turn, reduces or completely eliminates its mechanical injury.

The angle of inclination β of the brake section should be greater than the angle of friction of the crop ξ [17], loaded into a silo. This condition ensures the steady movement of grain cargo on the surface of the channel. Consequently, the choice and ratio of the angles of inclination of the acceleration and braking sections of POSC depend on formula (28) and the specific grade of grain with the appropriate friction angle ξ .

For most grain varieties, the friction angle lies in the range from 15° to 25° depending on the physical and mechanical properties and the level of moisture in the grain mass. Given this, the forming angles of key sections of POSC should be larger than the specified angular range, that is, for the braking section, the following requirement should be met: $\beta > \xi$. Under the most disadvantageous conditions of movement of grain flow, the angle β takes a value that exceeds the upper limit of the range of variation of the friction angle, namely – $\beta > 25^\circ$. At the same time, given the interde-

pendence (28) between the angles of the brake and acceleration sections of POSC, the α angle would be greater than 41° .

Taking into consideration the above-specified conditions when establishing the angles of inclination of POSC sections, a set of theoretical calculations was carried out (Fig. 4) on determining the patterns in the formation of the geometric characteristics of the screw channel and the kinematic parameters of grain flow movement.

Our analysis of the dependence shown in Fig. 3 has revealed that the main factor in the formation of the value of the angle β is the ratio between the key dimensional parameter of POSC – the radius r of the channel and the height of the grain fall h_0 . Thus, with its growth from 0.1 to 1, the angle of inclination of the brake section, taking into consideration the algebraic difference with an angle α , increases from zero to almost 50° . Taking into consideration the above restrictive conditions on the values for the angles of inclination of the channel sections, the angle β should be formed based on the value of the h_0/r ratio equal to 0.6...0.7 and above. In this case, a given angle is guaranteed to exceed the limit of 25° .

The next indicator that determines the geometrical structure of the screw channel is the number of turns of a particular section of the channel. The calculation of the number of turns employs formulas (32) and (37), and is focused on the compliance and fulfillment of several conditions. First, the geometric height of the acceleration and braking sections should not exceed the total height of the entire screw channel. Second, there must be a certain ratio between them in order to ensure permissible limits on the duration of acceleration and braking of grain flow.

According to the graphically displayed results of our calculations in Fig. 4, the number of turns n_{br} at a growing angle α tends to be almost linear in its increase, despite the number of turns on the acceleration section. The fastest such growth of n_{ac} from an increase in the α angle occurs at $n_{br}=1.2$ when the number of turns at the extreme points of the growing segment differs by 14 %. This is due to the strict ratio of α and β angles, not depending on the number of turns on the corresponding sections of the channel at a constant value of the h_0/r ratio.

6.2. Discussion of results of the experimental study and their correlation with the data from theoretical estimations

In accordance with the characteristics presented in Fig. 5, an increase in the angle α leads to an increase in the speed of movement, while the difference in speed at the extreme points of the range may differ by more than 0.4 m/s. This is primarily due to the increase in the level of the slope of the acceleration section. It should also be noted that with an increase in the h_0/r ratio, the growth rate of the maximum acceleration speed is more significant. Thus, at two extreme values of this ratio, under the condition of equality of the angle α , the speed differs by 0.1 to 0.4 m/s. This trend is explained by an increase in the radius r of the screw channel, which directly affects the length of the acceleration section and, accordingly, the duration of acceleration.

Experimentally, it was found that the angle of α should not exceed 45° , because its further increase led to the grain discharge at the beginning of the braking section due to the rapid gravitational shift of the grain flow through the acceleration channel. This statement is also confirmed theoretically, since, according to (28), at an angle of inclination of $\alpha > 45^\circ$, the angle $\beta < 21^\circ$, which is less than the lower limit of the angle of natural slope ξ for wheat grains.

Statistical treatment of the experimental data obtained (Table 1) demonstrates that the variability of the speed change for each angle α is quite small, and the deviation of current values from the average does not exceed 10...13 %. When checking the uniformity of experimental variance, it was found that the observational value of Cochran, $G=0.04525$, does not exceed its critical magnitude $G_{tbl}=0.6838$, selected based on the number of experiments, parallel studies, and accepted influence factors. This indicates an appropriate level of quality and reproducibility of our experiment.

Experimental error value and relative error values ($<10\%$) in the experimental and theoretical values for the maximum speed testify to the quite permissible boundaries of deviations for a given multifactor experiment considering the actual complexity of its full-time implementation.

The results from the theoretical and experimental studies on determining the speed (Fig. 6) of grain flow at the descent from a screw channel lead to similar conclusions. Statistical processing of our study results (Table 2) on determining the final speed also indicates the uniformity of research variance, in particular, the observational criterion of Cochran, $G=0.5446$, does not exceed its critical value of 0.6838. The values of the resulting speed within one experiment do not differ significantly from their averaged values. Relative errors do not exceed 12 %.

Statistical analysis of the experimental data and values of the residues of the final speed of grain descent (Tables 1–3) indicates the sufficient level and accuracy of our research. According to the RS criterion, the values of the residual series are normally distributed for the level of significance of 0.05 and $n=25$. The uniformity of the research variance, the coefficient of multiple correlations of the experimental and theoretical data on the resulting speed $R=0.998$, the average relative error of residues of 9.85 %, and their normal distribution indicate the adequacy of the model built. The comparison of the theoretical and experimental values of the maximum and resulting speed of grain movement by the value of relative error also indicates an acceptable level of accuracy of the presented theoretical model.

During our experiments, it was found that the resulting speed of grain descent from the channel (Fig. 6) was in the range from 1.8 m/s to 2.2 m/s at average estimated values of α about 1.98 m/s. This resulting speed is close to the initial one, which indicates the correctness of the ratios between the angles α and β (23) to (28), and the reliability of the built analytical model (40).

Our analysis demonstrates that the constructed model and the corresponding POSC, due to two variable angles of spirals, solves the task of controlled reduction of grain movement speed when loading it into silos without injury, in contrast to [26, 27]. At the same time, the proposed POSC structure is not bulky, compared to [22–24], and does not cause segregation effects noted in [19, 20].

Certain disadvantages of our model include the following: the model does not take into consideration air resistance, Coriolis force, and grain displacement from the center of the groove as a result of the action of centrifugal force. These disadvantages are insignificant due to the low speed of grain movement and do not affect the result. There are also objective difficulties in determining the optimal ratio of acceleration and braking angles for different cereals. To ensure a stationary flow of grain mass, it is necessary to take into consideration the angle of the natural slope of grain, depending on the variety of grain crops.

The prospects for further research are to study the feasibility of designing POSC with three different angles of inclination, as well as to study the need for the manufacture of POSC from different materials, depending on their friction properties.

7. Conclusions

1. A theoretical model of the gravitational movement of grain in an open screw channel with two variable angles of inclination has been built and substantiated. The model makes it possible to obtain the speed of movement of grain at any time t , takes into consideration the radius of the channel r , the height of the bunker hole h_o from the edge of the acceleration section, the friction coefficient μ , and the angles of inclination of the spirals α and β on the acceleration and braking sections.

2. We have derived the ratio between the angles of inclination α and β of the acceleration and brake sections. This dependence ensures the passage of grain without its discharge on any part of the channel and, at the same time,

prevents injury to the grain mass due to a controlled reduction in the resulting speed.

3. The parameters of the reported analytical model have been studied, namely: expressions are given to determine the time of passing the grain on the acceleration section t_{ac} and the braking section t_{br} , as well as dependence to find the number of turns n_{br} on the brake section relative to the arbitrary number of turns n_{ac} on the acceleration section.

4. Based on the analytical model, a technical description of the peripheral open screw channel has been proposed. For a given channel, the values of the recommended angles were substantiated, $41^\circ\text{--}45^\circ$, for the acceleration section, and $39^\circ\text{--}35^\circ$ for the brake section, as well as the h_o/r ratio that should be at least $0.6\text{--}0.7$.

5. We have compared the results of studying the movement of winter wheat with a moisture content of 14 % in POSC with the estimation data from the model built. Statistical analysis of the theoretical and experimental data has revealed the adequacy and acceptable accuracy of the proposed model. The difference of the obtained results does not exceed 13 %. That makes it possible to apply the model for further research purposes.

References

- Kong, E., Liu, D., Guo, X., Yang, W., Sun, J., Li, X. et. al. (2013). Anatomical and chemical characteristics associated with lodging resistance in wheat. *The Crop Journal*, 1 (1), 43–49. doi: <https://doi.org/10.1016/j.cj.2013.07.012>
- Komchenko, E. V., Basyuk, S. P. (2003). Vliyanie materiala stenok bunkera na istechenie razlichnyh sypuchih materialov. *Energosberezhenie i energosberegayushchie tekhnologii v APK*, 1, 145–149.
- Goryushinskiy, I. V., Mosina, N. N. (2001). K voprosu otsenki protsessa zagruzki emkostey sypuchimi materialami. *Sbornik nauchnyh trudov studentov, aspirantov i molodyh uchenykh SamIIT*, 3, 83–84.
- Arendarenko, V. M., Antonets, A. V., Savchenko, N. K., Samoilenko, T. V., Ivanov, O. M. (2020). Calculation model of grain gravitation movement in sloping passage with discrete variable inclination angle. *Bulletin of Poltava State Agrarian Academy*, 4, 273–282. doi: <https://doi.org/10.31210/visnyk2020.04.35>
- Samoilenko, T. V., Arendarenko, V. M., Antonets, A. V. (2020). Kinematics of grain movement on a spiral device with variable angle of descent. *Bulletin of Poltava State Agrarian Academy*, 1, 267–274. doi: <https://doi.org/10.31210/visnyk2020.01.31>
- Goryushinskiy, I. V., Mosina, N. N. (2003). Povyshenie kachestva funktsionirovaniya bunkernykh hranilisch uluchsheniem ih zagruzki. *Puti povysheniya effektivnosti APK v usloviyakh vstupleniya Rossii v VTO. Materialy mezhdunarodnoy nauchno-prakticheskoy konferentsii (k XIII mezhdunarodnoy spetsializirovannoy vystavke «AGRO-2003»)*, 343–345.
- Tarasenko, A. P., Orobinskiy, V. I., Gievskiy, A. M., Baskakov, I. V., Chernyshov, A. V., Haritonov, M. K. (2019). Snizhenie travmirovaniya zerna pri posleuborochnoy obrabotke. *Vestnik agrarnoy nauki Dona*, 1, 63–68. Available at: <https://readera.org/140243652>
- Tarasenko, A. P., Orobinskiy, V. I., Gievskiy, A. M., Merchalova, M. E. (2012). Sovershenstvovanie sredstv mekhanizatsii dlya polucheniya kachestvennogo zerna. *Vestnik Voronezhskogo gosudarstvennogo agrarnogo universitet*, 3, 109–115.
- Zharkikh, V. U., Tarasenko, A. P. (2015). Overview of technical solutions for even loading of grain cleaners. *Nauchno-issledovatel'skie publikatsii*, 1 (3 (23)), 76–81. Available at: <https://cyberleninka.ru/article/n/obzor-tehnicheskikh-resheniy-dlya-ravnomernoy-zagruzki-zernoochistitelnyh-mashin/viewer>
- Strona, I. G. (1974). Travmirovaniya semyan zernovykh kul'tur i urozhayev. *Biologiya i tekhnologiya semyan*, 2, 122–129.
- Chazov, S. A., Shelyapen', P. A., Votskiy, Z. Z. (1981). Travmirovaniya semyan i puti snizheniya pri mekhanizirovannoy obrabotke, obmolote, sortirovani. *Ukrainskie nivyy*, 8, 41–43.
- Derev'ianko, D., Sukmaniuk, O., Sarana, V., Derev'ianko, O. (2020). Justification of influence of the working bodies of combine harvesters on damage and quality of seed. *Bulletin of Agricultural Science*, 92 (2), 64–71. doi: <https://doi.org/10.31073/agrovisnyk202002-10>
- Cherniy, A. S. (1973). Puti snizheniya povrezhdaemosti semyan pri rabote zernovoy norii NZ-20. *Trudy ChIMESKh*, 62, 270–275.
- Kupreenko, A. I., Isaev, Kh. M., Bychkov, I. E. (2019). Improving the efficiency of loading of tanks for agricultural purposes. *Konstruirovaniye, ispol'zovaniye i nadezhnost' mashin sel'skohozyaystvennogo naznacheniya*, 1 (18), 462–469.
- Fraczek, J., Ślipek, Z. (1999). Fatigue strength of wheat grains. Part 1. The analysis of grain deformation at multiple loads. *International Agrophysics*, 13 (1), 93–97. Available at: <http://www.international-agrophysics.org/Fatigue-strength-of-wheat-grains-Part-1-The-analysis-of-grain-deformation-at-multiple,106935,0,2.html>
- Omarov, A., Müller, P., Tomas, J. (2013). Influence of loading rate on the deformation and fracture behavior of wheat grains. *Chemie Ingenieur Technik*, 85 (6), 907–913. doi: <https://doi.org/10.1002/cite.201200054>

17. Borshchev, V. Ya., Dolgunin, V. N. (2006). Characteristics of Raped Shear Flow and Recommendations for Production Process. *Vestnik Tambovskogo gosudarstvennogo tekhnicheskogo universiteta*, 12 (2A), 401–407. Available at: <https://cyberleninka.ru/article/n/harakteristiki-sdvigovogo-potoka-zernistoy-sredy-i-rekomendatsii-po-organizatsii-tehnologicheskikh-protsessov/viewer>
18. Dolgunin, V. N., Borshchev, V. Ya. (2006). Bystrye gravitatsionnye techeniya zernistyh materialov: tekhnika izmereniya, zakonomernosti, tekhnologicheskoe primenenie. Moscow: Mashinostroenie.
19. Sevidzh, S. (1985). Gravitatsionnoe techenie nesvyazannyh granulirovannyh materialov v lotkah i kanalah. *Mekhanika granulirovannyh sred: Teoriya bystryh dvizheniy*. Moscow: Mir, 86–146.
20. Leuthe, F., Eisenhauer, N., Hofmann, B., Maier, M., Roth, K. (2017). The movement of a dune of non-uniform grain size in a circular pipe flow. *18th International Conferences on Transport and Sedimentation of Solid Particles*, 185–192.
21. Melnik, V. I., Samojlenko, T. V. (2018). Analysis of directions for improving the design of devices for loading silos. *Engineering of nature management*, 1 (9), 83–90. Available at: http://nbuv.gov.ua/UJRN/Iprk_2018_1_13
22. Dancey, C. L., Diplas, P., Papanicolaou, A., Bala, M. (2002). Probability of Individual Grain Movement and Threshold Condition. *Journal of Hydraulic Engineering*, 128 (12), 1069–1075. doi: [https://doi.org/10.1061/\(asce\)0733-9429\(2002\)128:12\(1069\)](https://doi.org/10.1061/(asce)0733-9429(2002)128:12(1069))
23. Pylypaka, S., Nesvidomin, V., Zaharova, T., Pavlenko, O., Klendiy, M. (2019). The Investigation of Particle Movement on a Helical Surface. *Advances in Design, Simulation and Manufacturing II*, 671–681. doi: https://doi.org/10.1007/978-3-030-22365-6_67
24. Ren, J.-L., Zhou, J.-N., Han, L., Hu, Y.-J. (2018). Analysis of the Law Governing the Movement of Bulk Materials in a Vertical Helical Conveyer. *Reneng Dongli Gongcheng/Journal of Engineering for Thermal Energy and Power*, 33 (6), 77–82. doi: <https://doi.org/10.16146/j.cnki.rndlgc.2018.06.013>
25. Borshchev, V. Ya., Dolgunin, V. N., Dronova, M. Yu. (2005). Cascade Gravity Separation of Particulate Solids: Technological Peculiarities and Mathematical Modeling. *Vestnik TGTU*, 4, 903–909. Available at: <https://cyberleninka.ru/article/n/kaskadnaya-gravitatsionnaya-separatsiya-zernistyh-materialov-osobennosti-tehnologii-i-modelirovanie/viewer>
26. Antipov, S. T., Zhuravlev, A. V., Nesterov, D. A. (2015). Mathematical motion simulation of millet grains in the drying device with weighed-twisted layer. *Tekhnologii pischevoy i pererabatyvayushey promyshlennosti APK – produkty zdorovogo pitaniya*, 4, 46–53. Available at: <https://cyberleninka.ru/article/n/matematicheskoe-modelirovanie-dvizheniya-zerna-prosa-v-sushilnom-aparate-so-vzveshenno-zakruchennym-sloem/viewer>
27. Negi, S. C., Lu, Z., Jofriet, J. C. (1997). A Numerical Model for Flow of Granular Materials in Silos. Part 2: Model Validation. *Journal of Agricultural Engineering Research*, 68 (3), 231–236. doi: <https://doi.org/10.1006/jaer.1997.0197>
28. Ukolov, A., Dolgunin, V., Romaanof, A., Klimov, A. (2001). Gravity separation technology of particulate materials of high uniformity. *International Conference on Practical Aspects Technology*, 215–218.
29. Shatskiy, V. P., Orobinskiy, V. I., Popov, A. E. (2015). Modelirovanie dvizheniya zernovogo potoka v gravitatsionnom separatore. *Vestnik Voronezhskogo gosudarstvennogo agrarnogo universiteta*, 4, (47), 72–79. Available at: <http://vestnik.vsau.ru/wp-content/uploads/2015/11/72-79.pdf>
30. Morozov, I. V., Dudin, O. V. (2003). Model traiektoriyi rukhu zerna po poverkhniakh silskohospodarskykh mashyn. *Visnyk Kharkivskoho derzhavnogo tekhnichnogo universytetu silskoho hospodarstva «Mekhanizatsiya silskohospodarskoho vyrobnytstva»*, 21, 124–131.
31. Hevko, B. M. (2012). Matematychna model rukhu zerna po rukhomym poverkhnyam vysivnykh aparativ. *Zbirnyk naukovykh prats Vinnytskoho natsionalnoho ahrarnoho universytetu. Tekhnichni nauky*, 1 (11), 113–118.
32. Lezhenkin, O., Holovlov, V., Mikhailenko, O., Rubtsov, M. (2019). Mathematical model of the movement of the combed grain heap after stripper harvesting module in the air flow. *Proceedings of the Tavria State agrotechnological university*, 19 (3), 14–21. Available at: <http://oj.tsatu.edu.ua/index.php/pratsi/article/view/236>
33. Naumenko, M. M., Sokol, S. P., Filipenko, D. V., Guridova, V. A. (2017). Mathematical model of the grain mix in a cylindrical grid rotating around the axis. *Heotekhnichna mekhanika*, 133, 250–256.