

*The study was devoted to solving the issue of creating new electric heating devices that can be used in autonomous heat supply systems. The issues were resolved by developing an original low-pressure electric steam heater. The study was aimed at improving the efficiency of heat supply systems for buildings and structures. Given the current trends in the global striving for energy conservation, it cannot be fully realized without the introduction of high-tech and low-energy-consuming electrical equipment. As a result of the theoretical studies of a heat pipe with an electric heater, a design of an electrovacuum heating element has been developed. The low-pressure electric steam heater can be used in heat supply systems of autonomous users. Thermal energy transfer is currently accompanied by substantial energy losses since the heat carrier has to pass considerable distances. Switching of the facility to the heating plant is impossible in some cases because of technical problems or significant material costs for laying pipelines. As a result of the study, the dependence of heating the heat pipe at various volumes of the heat carrier and mass of the pipe itself was established. When a certain mass is reached, the temperature of the heating surfaces can reach 70 °C which is considered acceptable. The experimental data obtained have made it possible to develop an electric heater of new generation with a fundamentally new design of the heating element. It combines the efficiency of an electric spiral and comfortable warmth from a traditional radiator. This heater is an explosion and fire-safe and can be integrated into the Smart Home system*

**Keywords:** heating radiator, electric heater, energy saving, heat supply system, heating device, autonomy, energy efficiency, electricity

UDC 621.165  
DOI: 10.15587/1729-4061.2021.237873

## DEVELOPMENT OF LOW-PRESSURE ELECTRIC STEAM HEATER

**Ali Mekhtiyev**

PhD, Professor

Department of Electrical Equipment Operation  
Kazakh Agrotechnical University named after S. Seifullin  
Zhenis ave., 62, Nur-Sultan,  
Republic of Kazakhstan, 010011

**Iossif Breido**

Doctor of Technical Sciences, Head of Department  
Department of Automation of Production Processes\*

**Rustam Buzyakov**

Master of Engineering Science, Doctoral Student\*

**Yelena Neshina**

Corresponding author

Master of Science in Engineering, Head of Department  
Department of Power Systems\*

E-mail: 1\_neg@mail.ru

**Aliya Alkina**

Master of Technical Sciences, Senior Lecturer  
Department of Information Technologies and Security\*

\*Karaganda Technical University

N. Nazarbayev ave., 56, Karaganda,  
Republic of Kazakhstan, 100027

Received date 23.06.2021

Accepted date 29.07.2021

Published date 31.08.2021

**How to Cite:** Mekhtiyev, A., Breido, I., Buzyakov, R., Neshina, Y., Alkina, A. (2021). Development of

low-pressure electric steam heater. *Eastern-European Journal of Enterprise Technologies*, 4 (8 (112)), 34–44.

doi: <https://doi.org/10.15587/1729-4061.2021.237873>

### 1. Introduction

Search for energy-efficient solutions in the field of heating residential and industrial premises is an issue of very high topicality. Conventional centralized heating systems have a number of essential drawbacks, primarily, the necessity of circulation of liquid heat carriers through the pipeline system. This is connected with significant operating costs and heat losses in transportation. Significant funds are invested every year in the repair of existing communications and the laying of new heating networks. Heating residential and industrial premises with the use of electric heaters is still a rather expensive way to maintain microclimate in cold seasons though this type of heating has a definite prospect of use. Electric heaters are used in many countries as an alternative to central heating since laying and maintaining heat supply lines are quite expensive and their cost can exceed the cost of the project itself with pipelines of large length. Heating systems of pipe design are characterized by their liability to mechanical, freezing, and corrosive damages, heat carrier leakage, or clogging. For example, centralized heating systems are not practically used in South Korea, Japan, and

China, therefore there are no problems with their operation, thus, various kinds of autonomous heating systems including electric ones can serve as an alternative solution. With the development of the use of renewable energy sources and a decrease in the cost of electricity produced in this way, electric heaters can replace some types of heating systems including centralized ones.

The search for new energy-saving heat supply technologies that will partially replace centralized heating systems with autonomous ones is one of the priorities in scientific studies. Thermal energy must be produced close to the place of its consumption in order to exclude its losses during transportation. This is ensured by electric heating systems. What is considered there is a project of developing a low-pressure electric steam heater (LPESH) which can be used as a main heating device in the winter and as an additional device in off-seasons. LPESH is a new generation electric heater with a fundamentally new energy-saving heating element and an electronic control system. It will reduce the costs of heating the premises. The development of a reliable and fire-safe electric heater with the lowest production cost compared to oil radiators and converters is relevant not only for the Republic

of Kazakhstan but also for other countries with temperate and cold climates.

At the beginning of the twentieth century, Noirot Co. (France) has developed a spiral electric heater (EH) and organized its mass production [1]. This was a fairly simple and effective design with an electric coil inside an enclosure blown by a fan. In the 1930s, designs of oil heaters were developed in which a tubular heating element was immersed in oil contained in a sealed housing. Infrared heaters can be noted which are also used both in everyday life and industry. They have their advantages and disadvantages.

---

## 2. Literature review and problem statement

---

Publication [2] presents the results of studies of an integrated power plant. New devices such as indirect heat exchangers, plastic heaters of various configurations combining high-pressure feedwater streams and low-pressure mass streams of condensate were presented. However, the efficiency of such systems is not high enough. Calculation of a thermal system for a power plant with installed pressure water reservoirs was described in [3]. A maximum increase in electrical power of the unit was found when regenerative low-pressure heaters were turned off. To reduce power production by the plants during off-peak night hours, water heated in regenerative low-pressure heaters and feed water heated in tanks to nominal temperature is sent to elevated water tanks. The water accumulated overnight is used to feed the boiler during peak electricity demand periods. However, the issue of the drop in the electric power of the power unit with reservoirs of various capacities and the periods of their charging was not solved in [3].

As described in [1], convectors have a fairly high efficiency but they burn household dust during operation thereby polluting the room atmosphere and creating an unpleasant odor. Oil convectors create quite a comfortable warmth but they contain oils that are prone to degradation and inflammation in a case of a thermostat failure or overturn [1]. Infrared EHs are not recommended for residential use as they can cause fire too. The use of additional protection for filters and humidifiers for converters leads to a significant increase in their cost and the use of expensive synthetic oils for oil heaters. Additional protection also leads to an increase in their cost. A significant number of unsolved problems [1] with existing EHs as well as the fundamental impossibility to achieve positive results because of a significant cost component can be pointed out. In terms of improving the design, it is impossible to achieve a reduction of the EH cost. This makes the corresponding studies impractical. Also, it is completely impossible to achieve a high degree of fire safety of existing EH designs in their mass production.

The classical linear thermoacoustic theory was integrated in [4] by means of numerical calculation with the use of a simple energy conservation model which makes it possible to estimate the optimal length of thermoacoustic heat exchangers and the value of corresponding heat transfer coefficients between the gas and solid walls. Despite the studies, numerical results agree with measurements of the heat transfer coefficient given in literature with an accuracy of up to 20 %.

Studies in [5] are devoted to a new system type with two energy sources with heat pumps and energy storage systems. Taking into account the economic effect at which the cost of system operation is 55 % of the cost of a conventional heat

pump system with an air source, the findings confirm the feasibility of creating new electric heating devices for use in autonomous heat supply systems.

Similarly, study [6] substantiates the need for the creation of autonomous heat supply systems to eliminate problems of environmental pollution. In addition, the switch to clean thermal resources will reduce coal use by about 41 %.

The advantages of heat pumps described in [7] lead to the conclusion that a heat pump with an air source integrated with a water storage tank has significant energy-saving potential. However, such heating systems are not suitable for countries with cold climates because of significant operating costs connected with the operation of electric equipment. It also requires significant investments in the arrangement of an underground loop for the extraction of low-potential heat from the earth's depth.

There are electric convectors and oil heaters in the market (in the overwhelming majority produced in China) which suffer a series of essential drawbacks [8]. An important point is that electric convectors, infrared and oil heaters are widely used as additional heating devices, however, there is information about their potential danger in terms of fire safety as the experiments proved their high fire hazard [9]. It is important to notice the high demand for electric heating systems capable of using renewable energy sources.

The main problems of the development of electric heating systems and proposed solutions are described in detail in [10]. The problem of energy supply efficiency can be solved through the design and implementation of devices that will significantly reduce energy consumption and optimize modes of working with energy sources [10].

To solve the problem of increasing the efficiency of heat supply systems and transition to autonomous electric heating systems, it is necessary to develop an EH with high operational safety and reliability and equipped with present-day electronic control systems. It is necessary to achieve maximum comfort of use and efficiency of the heating device. The idea implies using convective and low- or medium-temperature, long- and medium-wave infrared radiation for heating premises of any type [10]. Accordingly, the heating temperature will vary, if necessary, within 50 to 250 °C depending on the room type. In this case, the design must be simple and durable. This type of electric heater can be used in everyday life and industry. It can replace conventional oil radiators. Convection heat exchange has a number of disadvantages compared to infrared heating [10].

Taking into account the above, it is advisable to conduct studies aimed at the development of an EH of a new generation. A low-pressure electric steam heater can be an object of such studies. This EH will combine the advantages of electric spiral heaters, converters, and oil heaters into a single whole.

The projects realized in many cities make provision for electric heating systems and liquidation of low-efficient boiler shops most of which run on liquid and solid fuels. This marks the beginning of the transition to pipeless heating systems. The significance of the studies that were carried out is in the creation of a prototype and organization of production of electric heaters of a new generation that meet all present-day requirements of national and international programs in the field of energy conservation. European countries are worth mentioning where there are practically no central heating systems in operation.

**3. The aim and objectives of the study**

The study objective implied the development of an electric heating device, namely, a low-pressure electric steam heater that can be used in autonomous heating systems. This will make it possible to replace conventional oil heaters and compete with existing electric heaters.

To achieve the objective, the following tasks were set:

- carry out theoretical studies of the heat transfer process in an electrovacuum heater using the Fourier transform;
- develop the design of an electrovacuum heating element;
- carry out experimental studies of an electrovacuum heater of the LPESH section;
- develop the LPESH prototypes with an automatic system of operation control.

**4. The study materials and methods**

The proposed LPESH is based on the well-known heat pipe effect [10]. The information obtained served as the basis for the development of an LPESH which is highly efficient and creates comfortable warmth for humans. The LPESH is a fully automated EH equipped with a climate control system. It is also possible to combine it with the Smart Home system. Its operating modes are controlled using a remote control or a smartphone.

Copper 20, 28, 32 mm dia. pipes weighing 270 to 530 g and having a length of 250 to 450 mm were used in the experiments. 60, 80, and 100 W electric spirals were used. The volume of heat carrier poured into the vacuum pipes varied from 10 to 15 ml. Various pressures were created inside the vacuum pipe: 5–10 kPa (0.05–0.1 atm). A total of 40 different pipes with electrovacuum heaters were fabricated and tested. The temperature was measured using a Fluke 51 contact thermometer (Fluke, USA) with laboratory accuracy of 0.05%+0.3 °C atm with a measurement limit of up to 900 °C atm (1,600 °F) and a 4-channel HT-9815 digital thermometer (Xintest, China) with a temperature measurement range of -200 °C atm to +1,372 °C atm having an accuracy of 0.1 %. To create a vacuum inside the heat pipe, a Pfeiffer DUO 6/M series vane vacuum pump (China) with a built-in vacuum meter was also used. This two-stage fore pump is capable of operating in low and medium vacuum ranges up to 10<sup>-3</sup> mbar. Distilled water (GOST 6709-72) was used as a heat carrier. The volume of the heat carrier was controlled by a dosing device (a 60 ml syringe, GOST 24861-91) with an accuracy of 1 ml. The heating element was connected to a 220 V AC main of industrial frequency of 50 Hz through a Latr (laboratory autotransformer) with the help of which parameters of electric power of the heater were set. Power consumption of the electric heater was monitored using two UNI-T UT61B multimeters (China). One of them worked in current measurement mode, the other in voltage measurement mode. This device was able to automatically select measurement limits and had a PC connector. A Diagram of measuring parameters of the electrovacuum heater is shown in Fig. 1.

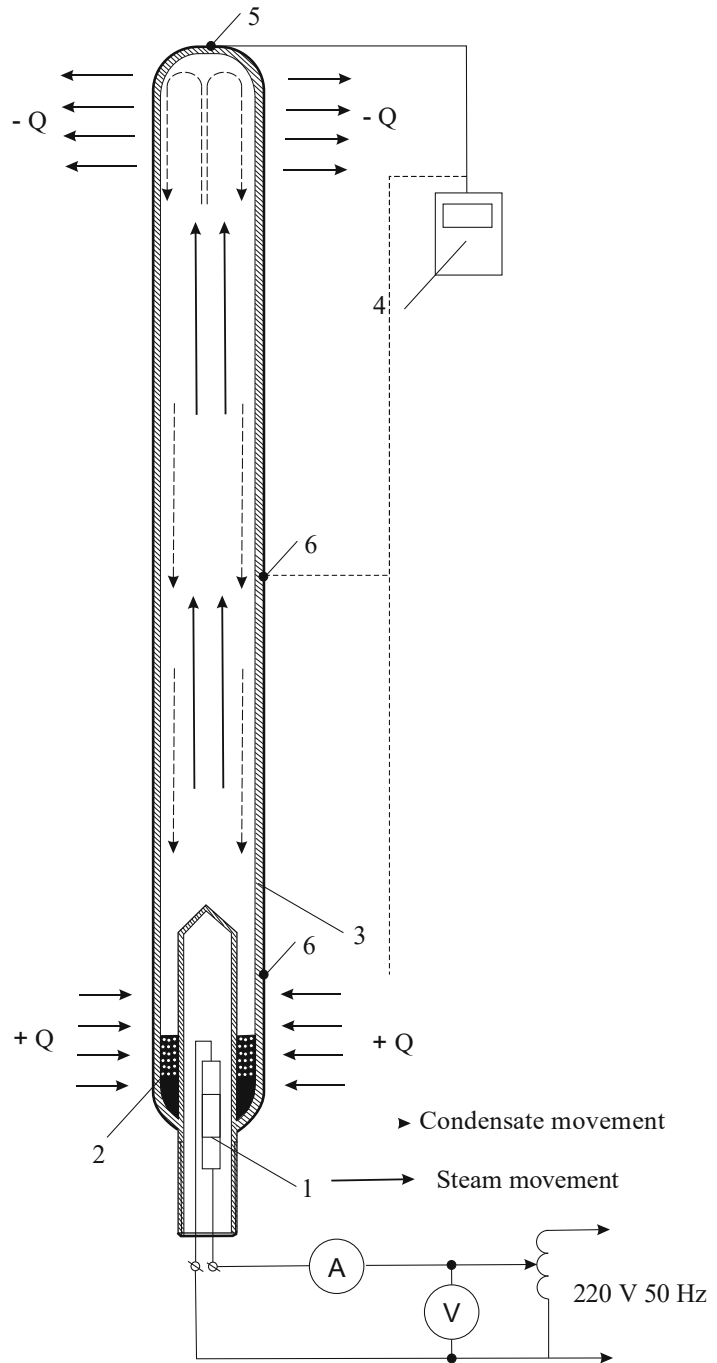

Fig. 1. Schematic diagram of measuring parameters of the electrovacuum heater: 1 – electric heater; 2 – boiling zone of the heat carrier; 3 – heat pipe body; 4 – temperature control device; 5 – constant temperature control point; 6 – periodic temperature control points

A sealed copper pipe closed on both sides was the study object. Following requirements were set: the pipe must be in a strictly vertical position, as shown in Fig. 1. The pipe was preliminarily placed in a freezer to freeze the heat carrier inside it. This made it possible to pump out the air from the pipe without the removal of the heat carrier. The DUO 6/M vane vacuum pump was used to evacuate the air. The pressure inside the vacuum pipe ranged from 5 to 10 kPa (0.05–0.1 atm) while maximum energy values of heat transfer were achieved at minimum pressure. Pipes with the lowest pressure were se-

lected for the experiment. There was a 6 mm dia. copper pipe in the upper part of the electrovacuum heater through which air was pumped out. Subsequently, the pipe was constricted at the very base and sealed with a gas burner and copper-phosphorus solder. The heat carrier did not have time to go into a liquid state during this soldering process since heating lasted for a short term and the soldering area was outside zone 2 (Fig. 1). The course of thermal processes featured the condition for heating the pipe in the bottom part. The arrows in Fig. 1 show the heat input zone (+Q). The arrows in the top part of the pipe show the zone of heat emission to the ambient space (+Q). The temperature was measured with two instruments. The hottest areas of the heat pipe were found using a Fluke 51 laser temperature meter (Fluke Co., USA). The heating temperature was continuously controlled using an HT-9815 4-channel digital thermometer (Xintest Co., China). Sensors were fixed in positions 5 and 6 (Fig. 1). The maximum heating temperature of the pipe surface was reached in the top part of the heat pipe (position 5, Fig. 1). The sensors fixed in position 6 made it possible to control the temperature in the bottom and middle parts of the heat pipe. Subsequently, when constructing the graphs, the temperature of the heated surface of the heat pipe was taken into account only in the top part since it was the highest (position 5, Fig. 1).

To process the experimental data, tools of the Microsoft Excel table processor (USA), quadratic interpolation of the function (solid line), and results of the root-mean-square approximation (dashed line) were used. Regression analysis was performed as well. Adequacy of the obtained approximations was checked using the Microsoft Excel (USA) and Wolframalpha (USA) software. A numerical study was carried out using the Wolframalpha program (USA) which is an interactive system for processing experimental results focused on working with data arrays. The Akaike Information Criterion (AIC) was taken into account. It is used exclusively for selection from several statistical models. Absolute and relative errors were calculated using this program and the Student's coefficient was determined at a confidence interval of 0.95.

The data obtained were analyzed to determine the optimal degree of conversion of electrical energy into thermal energy for various parameters of the electrovacuum heater. Mathematical apparatus of the theory of convective heat and mass transfer was used for theoretical studies. The electrovacuum heater being an electric heat pipe is the LPESH basis. The pipe was of an improved design and adapted to the use of electric current to heat the heat carrier. Theoretical studies of the process of heat transfer across the pipe wall and the wick saturated with liquid were initially carried out using the Fourier transform. The Clausius-Clapeyron relation was taken into account to describe convective heat transfer by steam that occurred inside the heat pipe. The mathematical apparatus of basic thermodynamics laws and the theory of heat and mass transfer were applied. Concepts of a thermal process were also used in which a shearing force is formed at the liquid-steam interface. This force tending to tear liquid away from the wick surface was proportional to the product of the dynamic pressure of the moving steam and the area of individual pores on the wick surface.

To develop the LPESH design, geometric modeling was performed using computer-aided design tools and a three-dimensional design system Kompas-3D (Russia). This

program allows the researchers to perform topological 3D optimization of a product as well as analyze thermal conductivity and natural convection. Design documents for making the LPESH prototypes were completed with the help of the Kompas-3D system. Computational experiments were carried out to study heat and mass transfer in the LPESH of the electrovacuum heater.

The theory of probability and statistics was used to substantiate the required number of experiment iterations to establish parameters of the electrovacuum heater in order to ensure sufficient reliability of the experimental study results. It was established based on the coefficient of variation  $K_{var}$  and defined as the ratio of standard deviation to the mean one [11]. The required number of experiment repetitions was set based on the  $K_{var}$  coefficient and the required degree of accuracy.

The value of the variation coefficient was determined from the formula:

$$K_{var} = \frac{100 \cdot \delta}{\chi}, \quad (1)$$

where  $\delta$  is the standard deviation;  $\chi$  is the arithmetic mean.

The value of the root mean square deviation was calculated from the formula:

$$\delta = \sqrt{\frac{\sum \delta_i^2}{N - n}}, \quad (2)$$

where  $\delta_i$  is the deviation of individual results from the group averages;  $N$  is the total number of experiments;  $n$  is the number of experimental groups.

To establish the necessary number of experiments, the permissible value of  $K_{per}$  was set in percentage. Knowing the coefficient of variation  $K_{var}$  for a given test method, it was possible to determine the required number of experiments with a reliability of 0.95. According to the results of numerous experimental data,  $K_{per}=12\%$  was taken with  $K_{var}=11.5\%$ . The necessary number of experiments equal to 4 corresponded to this coefficient (at a confidence level of 0.95).

---

## 5. The results obtained in the study of the electrovacuum heater

---

### 5.1. The results obtained in theoretical studies of the heat transfer process occurring in the electrovacuum heater using the Fourier transform

A heat pipe forms the electrovacuum heater basis [10]. It takes part in the process of establishing the mode of operation of a heat pipe with a liquid heat carrier. In this case, it was distilled water. It is known that water in its steam phase flows continuously from the evaporation zone to the condensation zone and returns to the evaporator in a liquid phase. In this process, steam moves from the evaporator to the condenser and there is a pressure gradient along the formed steam channel in the steam flow [12]. Under the action of the pressure gradient in the liquid, the liquid moves from the condenser to the evaporator. To achieve a balance, pressure from the liquid side acting on the liquid-steam interface along the entire length of the pipe must differ from pressure at the steam side, except for the point where the boundary is



minimal and equal to zero [13, 14]. The heat pipe can operate below the limit of the transferred power, so this process is characterized by the heat transfer coefficient:

$$Q = AU_{HP}(T_{p,l} - T_{p,c}), \tag{3}$$

where  $Q$  is the transferred power (heat load);  $T_{p,e}$  is the temperature of the outer surface of the heat pipe evaporator;  $T_{p,l}$  is the temperature of the outer surface of the pipe condenser;  $U_{HP}$  is the heat transfer coefficient related to an arbitrary cross-sectional area  $A$ .

Main methods of heat transfer in a heat pipe can be distinguished:

- through the body wall and a wick saturated with liquid in the evaporation zone;
- axial convective transfer of latent heat of vaporization from the evaporator to the condenser;
- through a wick saturated with liquid and the body walls in the condenser with subsequent condensation in this area.

Using the Fourier transform, it is possible to express the heat transfer process across the pipe wall and the wick saturated with liquid. The Clausius-Clapeyron relationship describes convective heat transfer by steam. The temperature difference between liquid and steam at the interface is usually very small and can be neglected. In accordance with the Fourier law, the heat flux occurring due to the temperature gradient can be calculated from the formula [10]:

$$Q = \frac{1}{R}(T_1 - T_2), \tag{4}$$

where  $R$  is thermal resistance determined from the following expressions:

- for a flat wall:

$$R = \frac{\delta}{kA}, \tag{5}$$

- for a cylindrical wall:

$$R = \frac{\ln(r_2/r_1)}{2\pi Lk}, \tag{6}$$

where  $\delta$  is the wall thickness, m;  $k$  is thermal conductivity, W/(m<sup>2</sup>·K);  $A$  is surface area, m<sup>2</sup>;  $L$  is the cylinder length m;  $r_1$  and  $r_2$  are the inner and outer radii of the cylinder, m, respectively. Temperature and steam pressure are related as follows [10]:

$$T_1 - T_2 = \frac{T_v(P_1 - P_2)}{\rho_v \lambda J}. \tag{7}$$

Using the above equations for each zone of a simple heat pipe with different temperatures at different points gives the following results:

- pipe wall in the evaporation zone:

$$T_{p,e} - T_{pw,e} = \frac{\ln(r_0/r_i)}{2\pi L_e k_p} Q; \tag{8}$$

- wick in the evaporation zone:

$$T_{pw,e} - T_{wv,e} = \frac{\ln(r_i/r_v)}{2\pi L_e k_{e,e}} Q; \tag{9}$$

- steam channel:

$$T_{wv,e} - T_{v,c} = \frac{T_v(P_{v,e} - P_{v,c})}{\rho_v \lambda / Q} Q; \tag{10}$$

- wick in the condensation zone:

$$T_{wv,c} - T_{pw,c} = \frac{\ln(r_i/r_v)}{2\pi L_c k_{l,c}} Q; \tag{11}$$

- pipe wall in the condenser:

$$T_{pw,c} - T_{p,c} = \frac{\ln(r_0/r_i)}{2\pi L_c k_p} Q. \tag{12}$$

When summing up these equations, the following is obtained:

$$T_{p,e} - T_{p,c} = Q \left[ \frac{\ln(r_0/r_i)}{2\pi L_e k_p} + \frac{\ln(r_i/r_v)}{2\pi L_e k_{e,e}} + \frac{T_v(P_{v,e} - P_{v,c})}{\rho_v \lambda / Q} + \frac{\ln(r_i/r_v)}{2\pi L_c k_{l,c}} + \frac{\ln(r_0/r_i)}{2\pi L_c k_p} \right]. \tag{13}$$

Thus, the temperature characteristic of heat pipes can be represented by the following equation [10]:

$$Q = A_p (T_{p,e} - T_{p,c}) \left[ \frac{\pi r_0^2 \ln(r_0/r_i)}{2\pi L_e k_p} + \frac{\ln(r_i/r_v)}{2\pi L_e k_{e,e}} + \frac{T_v(P_{v,e} - P_{v,c})}{\rho_v \lambda / Q} + \frac{\ln(r_i/r_v)}{2\pi L_c k_{l,c}} + \frac{\ln(r_0/r_i)}{2\pi L_c k_p} \right]. \tag{14}$$

Sound limit, boundaries, boiling of heat carrier and liquid entrainment.

There are additional factors that reduce the efficiency of the heat pipe: sound effects, fluid entrainment, and boiling of the heat carrier. This is a key factor for a heat pipe so that the maximum possible transfer of heat energy at the temperature in question will be of the least importance. In turn, the importance of these various constraints depends on the different properties of heat carriers, lattice structures, and geometry of the heat pipes [10]. The fluid velocity in the heat pipe changes depending on the change in the mass flow rate in a constant cross-section of the air duct. Values of characteristics of the steam flow in the steam channel of the heat pipe are very close in size to characteristics of flow in the convergent-expanding nozzle. Functions of heat input and terminal include high speed, flow locking, and pressure recovery when operating in heat pipes.

The sonic limit is reached when the heat pipe operates at low vapor density and high flow rates. The law of ideal gas makes it possible to establish that [10]:

$$\frac{P_0}{\rho_0 T_0} = \frac{P_v}{\rho_v T_v}, \quad (15)$$

The axial flow density of the heat pipe steam is related to the axial heat flow by the following equation:

$$m_v = \frac{Q}{A_v \lambda} = \rho_v V_v. \quad (16)$$

Introducing the local Mach number  $M_v$  and the sound speed defined as  $\sqrt{\gamma_v R_v T_v}$  the equations can be written in the following form:

$$\frac{T_0}{R_v} = 1 + \frac{\gamma_v - 1}{2} M_v^2, \quad (17)$$

$$\frac{P_0}{P_v} = 1 + \gamma_v M_v^2, \quad (18)$$

$$m_v = \frac{Q_v}{A_v \lambda} = \rho_v M_v \sqrt{\gamma_v R_v T_v}. \quad (19)$$

In expressions (17) to (19),  $\gamma_v$  is the adiabatic exponent. It measures 5/3, 7/5, or 4/3 for a monatomic, diatomic, and polyatomic steam, respectively;  $R_v$  is the steam constant equal to the universal gas constant divided by the steam molecular mass.

Substitution of  $\rho_v$  and  $T_v$  values leads to the following expression:

$$Q = \frac{A_v \rho_0 \lambda (\gamma_v R_v T_0)^{0.5} M_v \left(1 + \frac{\gamma_v - 1}{2}\right)^{0.5}}{1 + \gamma_v M_v^2}. \quad (20)$$

The sonic limit is reached when the steam velocity at the outlet of the evaporator becomes sonic, i.e. when the Mach number  $M_v$  is equal to one at the outlet of the evaporator. Thus, the sound limit of the heat pipe  $Q_{s,\max}$  can be written as follows [10]:

$$Q_{s,\max} = A_v \rho_0 \lambda \left[ \frac{\gamma_v R_v T_0}{2(\gamma_v + 1)} \right]^{0.5}. \quad (21)$$

Expression (21) allows us to calculate the maximum transferred power of the pipe at the sound limit. Liquid and steam move in opposite directions in a heat pipe and a shear force arises at their interface. Provided that the steam velocity is high, a limit is reached at which liquid will be detached from the wick surface and brought away by the steam flow. This is the cause of a sudden and significant increase in circulation of the heat carrier until the liquid return system can no longer cope with the growing flow. This phenomenon contributes to an instant drying of the wick in the evaporation zone. The phenomenon of fluid entrainment was first discovered during sound testing of heat pipes.

The steam velocity in the heat pipe is many times higher than the liquid velocity. The shear force at the liquid-steam interface which tends to tear the liquid away from the wick surface is proportional to the product of dynamic pressure of the moving steam and the area of individual pores in the wick surface [10]:

$$F_s = K_1 \frac{\rho_v v_v^2 A_s}{2}. \quad (22)$$

The surface force  $F_t$  which holds the liquid in the wick is proportional to the product of the surface tension coefficient  $\sigma$  and the wetted perimeter  $C_s$  of individual pores in the wick surface, i.e. [10]:

$$F_t = K_2 C_s \sigma. \quad (23)$$

The formation of steam bubbles in the wick structure is undesirable as this can lead to overheated areas and impede liquid circulation. Thus, there is a constraint of heat flow associated with vaporization in the heat pipe, and this constraint is called a boiling constraint. There is a difference between the boiling constraint and other constraints. The boiling constraint is imposed on the radial heat flux density and the remaining constraints are imposed on the axial heat flux. If the geometry of the evaporator and surface distribution of the heat flux in the evaporator are constant, then the radial flux density is directly proportional to the axial heat flux. The formation of steam bubbles is limited only by the evaporation zone of the heat pipe since the liquid in the condenser is supercooled to a temperature lower than the saturation temperature corresponding to the pressure of the liquid at this point. This is the cause of the fact that there are no restrictions on the density of the radial heat flux for the condensation zone [10].

## 5. 2. Development of the design of an electrovacuum heating element

Electrovacuum heater forms the LPESH basis. Its design is shown in Fig. 2. It is a modified design of the heat pipe where an electric nichrome spiral 1 is the heat source and distilled water is the liquid heat carrier 2. Terminals 3 of the electric spiral are connected with a plug to the mains electric cable. Electric current passing along the spiral heats it and the heat carrier turns into steam under the action of the heat generated by it. Steam rises to the top of the sealed vacuum pipe 4. Walls of pipe 4 are heated and heat exchange occurs but when cooling down, the steam condenses on the pipe walls and flows down them to the bottom of the pipe where it heats up and evaporates again. The process of phase transition and operation of a known heat pipe is described in [15, 16]. The electric spiral is placed in a glass 5 closed with a cap on one side, so the electric coil does not come into direct contact with the heat carrier. The atmosphere inside the heat pipe is rarefied to 5.053 kPa (0.05 atm). The absence of air resistance allows thermal particles to move at the speed of sound inside the pipe 4.

The design of the electrovacuum heating element considered above provides faster heating of the LPESH section in comparison to the existing oil EHs. It was found that a section weighing about 230 grams heats up to 70 °C, in less than 5 minutes, which is 5 times faster than in a conventional oil heater. The main problem of providing reliable operation of the LPESH section consists in ensuring high tightness of the pipe since when it is depressurized and pressure increases to 0.1 atm, it leads to a problem with setting the required temperature. It can also be said that the electrovacuum heating element does not contain flammable oil. This fact makes it possible to escape the danger of ignition of the heat carrier inside the pipe.

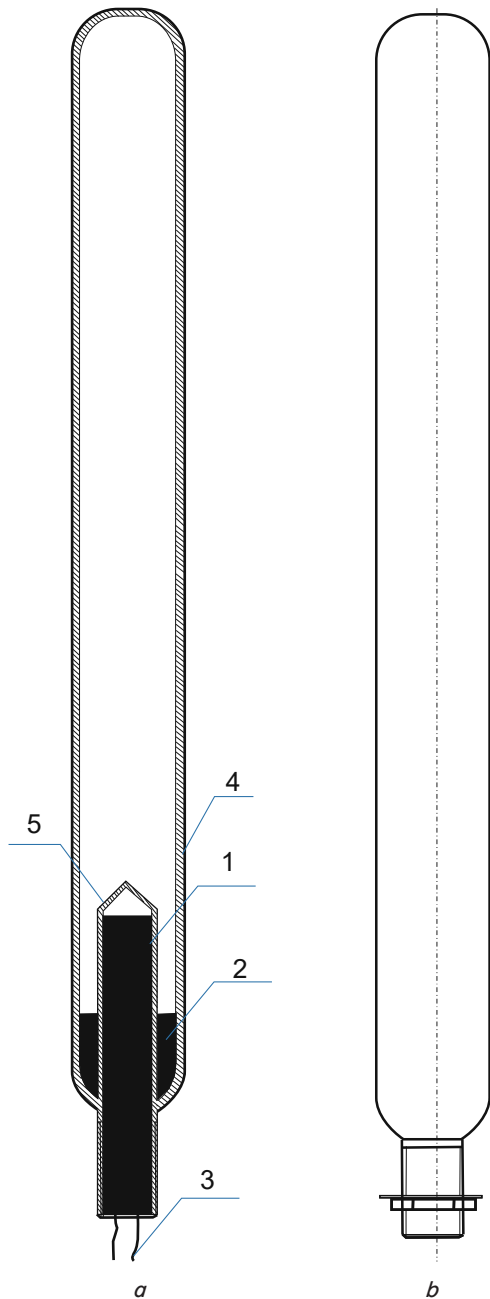

Fig. 2. Simplified view of the design of an electrovacuum heater of an electric low-pressure steam heater: 1 – Electric spiral; 2 – heat carrier; 3 – terminals of the electric spiral; 4 – heat pipe body; 5 – glass; a – sectional view of the electrovacuum heater; b – general view of the electrovacuum heater

**5. 3. Results of experimental studies carried out to improve the design of the electrovacuum heater**

Fig. 3 shows averaged data of temperature rise when the electrovacuum heater is turned on.

The heater parameters:

- the heat pipe diameter: 28 mm;
- mass: 355 g;
- the pipe length: 310 mm;
- the heater power: 80 W;
- heat carrier volume: 10 to 15 ml.

Fig. 4 shows averaged data of the temperature rise when a heat pipe with different volumes of heat

carrier (10 and 15 ml) is turned on. The pressure inside the pipe: 5.066 kPa (0.05 atm). Starting temperature: 24–25 °C atm, respectively. The pipe was cooled for the next experiment after each heating.

According to the measurement results, absolute error and relative error were calculated amounting to 0.75 °C Atm and 0.5 %, respectively. The Student’s coefficient was 2.228 at a confidence level of 0.95.

Fig. 4, 5 show the graphs of dependence of the heat pipe temperature on time at 10 and 15 ml of heat carrier and the dependence of temperature on the heat carrier volume (5 to 15 ml), respectively.

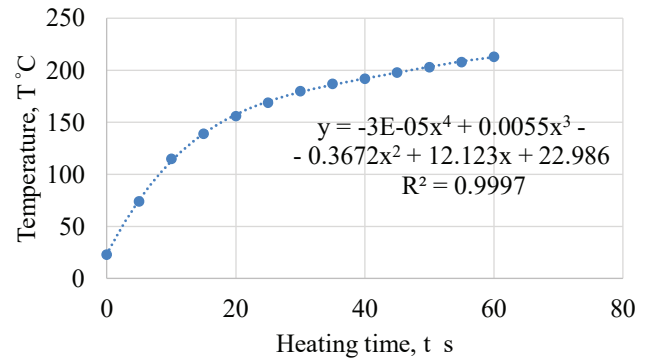

Fig. 3. Dependence of the heat pipe temperature on time

According to the measurement results, absolute error and relative error were calculated. They amounted to 7.55 °C Atm and 4.096 %, respectively. The Student’s coefficient was 2.228 at a confidence level of 0.95.

According to the measurement results, absolute error and relative error were calculated. They amounted to 1.17 °C Atm and 1.608 %, respectively. The Student’s coefficient was 2.262 at a confidence level of 0.95.

Experiments related to the determination of the mass of an 80 W electrovacuum heater were carried out. The volume of the heat carrier was 10 and 15 ml. The pressure inside the pipe was 5.066 kPa (0.05 atm). As the mass increased, the

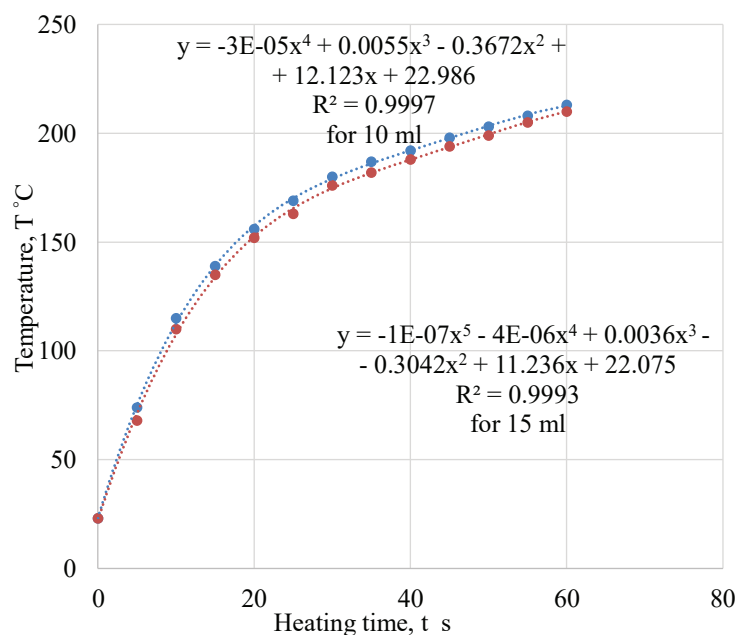

Fig. 4. Dependence of the heat pipe temperature on time at 10 and 15 ml of heat carrier volumes

surface temperature of the heater decreased. The tests were carried out with 5 samples of various masses from 230 to 530 grams, respectively, when heated from 130 °C to 216 °C. The dependence of change in the surface temperature of the body of the electrovacuum heater on its mass has been established. The graph is shown in Fig. 6.

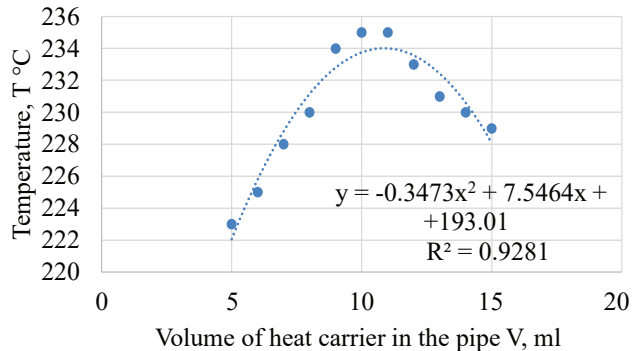

Fig. 5. The graph of dependence of temperature change on change of the heat carrier volume from 5 to 15 ml

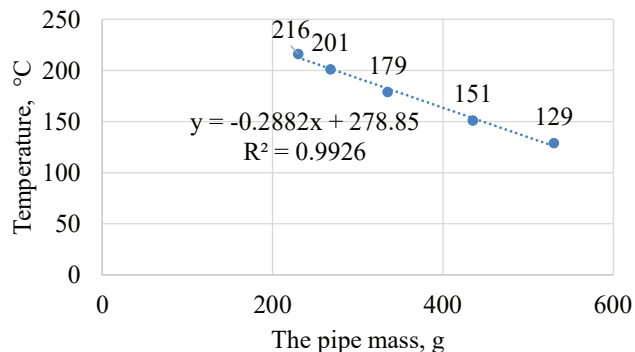

Fig. 6. Dependence of surface temperature of the electrovacuum heater body on its mass

Based on the measurement results, absolute error and relative error were calculated. They amounted to 2.32 °C Atm and 1.305 %, respectively. The Student's coefficient was 2.262 at a confidence level of 0.95.

The LPESH has an automatic power control depending on the ambient temperature in the room. Therefore, if necessary, the electrovacuum heater has a significant reserve of the dynamic range for adjustment.

It should be noted that present-day oil heaters have low maintainability rates. This leads to the fact that consumers cannot repair their heaters and are forced to contact specialized repair organizations. The LPESH sections have unified designs and make it possible to perform repairs at home.

**5. 4. The results obtained in the development of prototypes of a low-pressure electric steam heater with an automatic mode control system**

At the first stage of development of a prototype LPESH, capabilities of 3D computer modeling were used. Design solutions were worked out (Fig. 7) with their help. The appearance of the computer models is shown in Fig. 7. Also, the computer 3D model has made it possible to develop a set of drawings for the manufacture of two LPESH samples.

The principle of LPESH operation is described in detail in [15, 16]. The samples are conventionally divided into two types, each having its number. Their appearance is shown in Fig. 8.

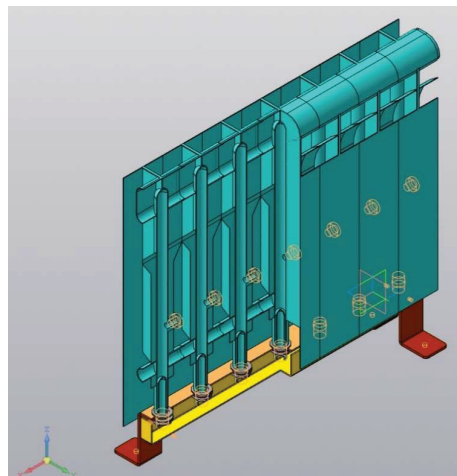

a

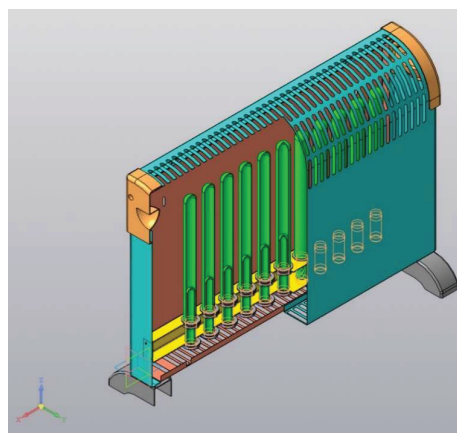

b

Fig. 7. 3D computer models of the low-pressure electric steam heater: a – 3D model No. 1; b – 3 D model No. 2



a



b

Fig. 8. External view of a laboratory prototype of a low-pressure electric steam heater: a – Sample No. 1; b – Sample No. 2

The LPESH has a modular design and is assembled from individual sections, 50 or 100 W each. Accordingly, in the future, consumers can independently add and subtract the EH sections to achieve the required power. This can be done independently according to the instructions and with no involvement of help from a qualified specialist. A typical section of an aluminum heater was taken as a basis. An electrovacuum heater was built in after a certain grade-up. One section is designed to heat 3 m<sup>2</sup> of living space with a ceiling



height of 2.5 meters. The LPESH can have elements for floor or wall mounting. It is equipped with a controller to regulate the heating temperature and can replace the conventional oil cooler since it is more economical thanks to the electronic control system and more efficient. The technological advantage consists in the high efficiency of heat transfer within the system without losses. The advantage of the LPESH over oil heaters consists in higher reliability and longer service life since it does not contain oil that degrades with time. The LPESH is absolutely safe in terms of explosion or fire if it leaks or falls to the floor. Water is used instead of expensive synthetic oil. This fact significantly reduces cost and facilitates the design of the electric heater. Low material costs for installation and operation of the heat supply system not achievable by competitors and 100 % automation of the process of dwelling heating was achieved.

One of the stages of creating an operable LPESH sample included the development of an automatic system for controlling its operation modes. An industrial temperature controller was used for control with a regulation range from 15 to 30 °C atm at the control step of 0.1 °C atm. Thanks to the use of the temperature controller with a wide control range, it becomes possible to adjust the heat exchange surfaces to any temperature. The unit has the ability to connect to a remote or wireless control system. The appearance of the temperature controller with a sensor is shown in Fig. 9. The load is switched off by an electromechanical relay with a switching current of up to 16 A. This is enough to simultaneously disable or enable two LPESHs. Accordingly, one control system is sufficient for one living room. It will control the operation of two LPESHs simultaneously. The main purpose of this controller consists in controlling the LPESH heating temperature and indoor air. This makes it possible to provide comfortable and safe space heating. It also provides an energy-saving mode of operation and does not allow it to overheat the LPESH. It can be integrated into a general Smart Home system with a minor revision of the electronic circuit of the automatic system. Accordingly, the Smart Home system will monitor the need to turn on and off the LPESH. This will reduce the cost of electricity for heating the living space.

The heating temperature of the LPESH heat exchange surfaces does not exceed the permissible level of 80 °C. This allows the owner to heat about 3 m<sup>2</sup> of dwelling with a single section at a power consumption of up to 0.05 kWh. It is possible to highlight some of the advantages of the LPESH in contrast to the centralized heat supply system. For example, wear of the flow path and occurrence of heat carrier leakage is impossible; absence of moving and rotating parts; there are no problems of corrosion and clogging of the flow path; absence of a circulation pump to create pressure in the pipeline system; there is no rigid connection to the heating device and the pipeline system. The service life of the LPESH is about 15–20 years without repair. It is possible to design a fully automated intelligent heating system with low energy consumption and high efficiency.

Fig. 10 shows an electrical diagram of the LPESH connected to the electrical

network through a standard plug. The LPESH is fed from a 220 V AC network but can operate from power sources with any kind of current and voltage. To adjust the LPESH operating mode, a temperature controller is used which measures temperature in the room and switches on and off the electric heaters R1, R2, and Rn according to the temperature settings. The red LED (VD<sub>1</sub>) provides visual control of the LPESH connection to the electric mains and the green LED (VD<sub>2</sub>) provides control of the electric heater on and off.

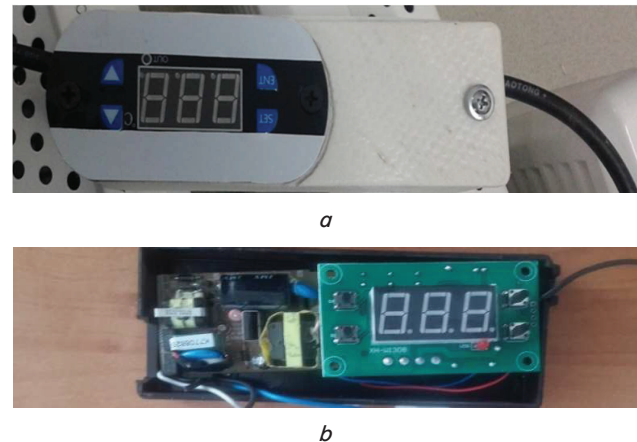

Fig. 9. Microprocessor control unit for operating the modes of a low-pressure electric steam heater: *a* – appearance of the control system unit; *b* – the unit without a back cover

Fig. 11 is a generalized diagram showing the main elements of the control system.

The control circuit shown in Fig. 11 is based on the use of the XH-W1308 temperature controller with a temperature sensor (China). The controller is powered by an AC converter with a rated voltage of 12 V DC. The controller operating range: –55 to +120 °C. The XH-W1308 temperature controller is made of widely produced electronic components such as the W2310 W3230 type. In the event of the failure of one electrovacuum heating element, the operation of the LPESH does not stop. It is also possible to refine it for integration into the Smart Home system.

electric heater on and off.

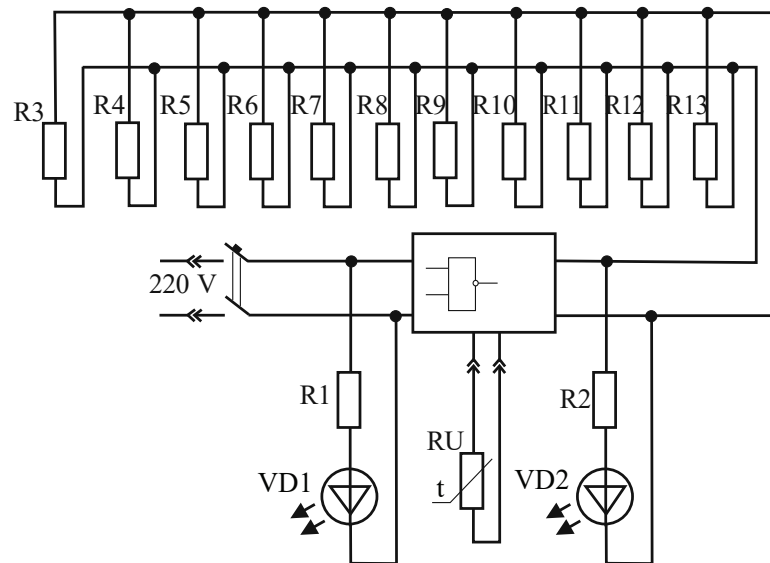

Fig. 10. Wiring diagram of an electric low-pressure steam heater

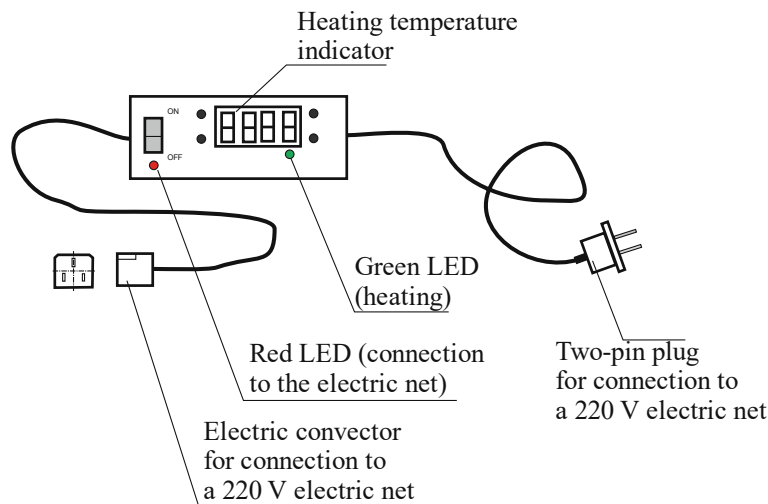

Fig. 11. Generalized diagram of the control system of a low-pressure electric steam heater

## 6. Discussion of the results obtained in the study of the development of prototypes of a low-pressure electric steam heater

The problems to be solved for the successful development of a new electric heating device were identified in the course of theoretical studies of the heat transfer process in an electrovacuum heater.

Achievement of positive results allows us to confirm our idea of using a small volume of water enclosed in the rarefied air space of the heat pipe. The existing methods of heating the heat exchange surfaces of an oil cooler are much outdated and ineffective, plus unsafe. The advantage of the proposed method is in higher thermal efficiency of the heater and higher rate of temperature rise. Studies have shown that maintaining the depth of vacuum inside the heat pipe is an important point. If the device body is damaged, its inner space is filled with atmospheric air, the temperature drops sharply and efficiency of use decreases. All the results obtained are united by a common direction of improving the efficiency of an electrovacuum heater which ultimately will make it possible to improve the LPESH design.

When carrying out experimental studies of an electrovacuum heater of the LPESH section, analysis of the obtained graphs has shown that the optimal volume of the heat carrier is from 10 to 15 ml. It was found that with an increase in volume by 20 ml or more, the temperature rise indices decrease and a decrease in the volume of the heat carrier by 10 ml or less negatively affects the pipe temperature reaching more than 200 °C atm. Accordingly, the volume of the heat carrier should be within the specified limits for a 28 mm dia. pipe. With an increase in the pipe diameter, as well as its length, the volume of the heat carrier increases proportionally. It was found that reduction of pressure inside the pipe from 5.066 kPa (0.05 bar) to 0.03 bar (3.01 kPa) will increase the efficiency of the electrovacuum heater by 15–20 %. This is due to a decrease in energy losses for friction in a more rarefied atmosphere and the heat transfer speed can reach the sonic speed. It was found in the studies that when the pressure in the inner cavity of the electrovacuum heater is higher than 0.1 atm, the effect of high-grade heating is completely lost and problems arise with setting the required temperature.

When analyzing the graph shown in Fig. 5, it can be concluded that temperature change depends on the heat carrier

volume. The most optimal volume was from 10 to 12 ml. With other volumes, lower indicators of the obtained power were achieved.

When analyzing the graph shown in Fig. 6, it can be concluded that the change in temperature of the electrovacuum heater body depends on its mass. To achieve the highest power transfer and an admissible maximum temperature of 80 °C, the mass of the electrovacuum heater should be about 650 g. This will make it possible to provide the electrovacuum heater with sufficient heat exchange surfaces for infrared or convective heating, e.g., provide it with convective fins made of duralumin and give it the shape of a heating radiator. It is also possible to embed an electrovacuum heater in a cement-sand mortar with a quartz aggregate and make on-wall ceramic electric heaters.

After the development of the design of the electrovacuum heating element, it was concluded that it was necessary to further improve the design of the electrovacuum heater and achieve pressure inside the pipe less than 5 kPa (0.05 atm). This would increase the heating temperature and thermal efficiency of the heater as a whole. So far, it has not been possible to obtain a ready-made sample of a heater with a pressure of less than 5 kPa and test it. Accordingly, there are limitations in achieving a higher heater temperature without increasing power consumption. This circumstance is still a drawback of this study; however, it will be eliminated in the future design of the heater. Also, the next step in improving the LPESH design implies the transition to induction heating. This will simplify the electrovacuum heater design and make it more technologically advanced to manufacture as well as ensure its operation at a lower pressure, less than 5 kPa. The development of this study can include the manufacture of an electrovacuum heater of steel or duralumin since the prototypes are made of copper so far. In the future, it is necessary to look for ways to reduce the cost of production of this type of EHs and reduce metal consumption as well as improve the technology of manufacture of electrovacuum heaters. A prototype electrovacuum heater embedded in a cement-sand mortar with quartz filler will be tested in a future study and ceramic wall-mounted electric heaters will be manufactured at reduced metal consumption for the EHs and increase the proportion of infrared heating. The technological advantage of the study is in the high efficiency of heat transfer without losses within the system.

## 7. Conclusions

1. When studying the main methods of heat transfer in a heat pipe, it was concluded that the heat pipe can function below the limit of the transferred power. This process is characterized by the heat transfer coefficient. The temperature characteristic of heat pipes was obtained taking into account additional factors (sound effects, fluid entrainment, and boiling of the heat carrier). This is a key factor for a heat pipe so that the maximum possible transfer of heat energy at the temperature in question will be the least important. Values of characteristics of the steam flow in the steam channel of the heat pipe correspond in size to the characteristics of the flow in the convergent-expanding nozzle. Heat input and terminal functions include high speed, flow blockage, and pressure recovery when operating in heat pipes. Thus, there is a lim-

itation of heat flow which is associated with vaporization in the heat pipe and this limitation was called boiling limitation.

2. A prototype low-pressure electric steam heater based on an electrovacuum heater was designed. An electric nichrome coil is the heat source in an electrovacuum heating element and distilled water is a liquid heat carrier.

3. The results of the experimental study of the electrovacuum heater of the LPESH section have shown that the selected heat carrier (water) has the best heat transfer parameters and in contrast to synthetic oil, it has no serviceable life limit. The study of parameters of the electrovacuum heater and volume of the heat carrier has made it possible to reach a temperature of 234 °C with an 80 W heater. With an increase in mass of the electrovacuum heater to 650 g, the maximum surface heating temperature will be 80 °C. It can be concluded that temperature change depends on the volume of the heat carrier. The most optimal volume is 10 to 12 ml and lower indicators of the released power are achieved with other volumes. It was found in the study that when the pressure in the inner cavity of the electrovacuum heater is higher than 0.1 atm, the effect of high-grade heating is completely lost and problems arise with the achievement of the required temperature. It was found that reduction of pressure inside the pipe from 5.066 kPa (0.05 bar) to 0.03 bar (3.01 kPa) will increase the efficiency of the electrovacuum heater by 15 to 20 %.

4. Two LPESH prototypes with an automatic system of controlling the operation modes have been designed. The power of the samples was 600 and 800 W but if necessary, it can be increased to 2,000 W by adding new sections with electrovacuum heaters. The achieved technical indicators of prototypes of electric heaters make it possible to provide more

than 20-year service life at a constant efficiency of 90 %. The LPESH can be used in two versions: for radiant-convective or radiant heating of premises. The experimental data have made it possible to develop an electric heater of new generation with a fundamentally new design of the heating element that combines the efficiency of an electric coil and comfortable heat of traditional heating radiators. This EH can be integrated into the Smart Home system. The high reliability of the electrovacuum heater has been confirmed empirically when it was switched on for 36 months at a surface temperature of 80 °C. The developed automatic control system provides a heating temperature control range from 15 to 30 °C atm at the control step of 0.1 °C atm. The LPESH tests have shown that this type of electric heater is fire and explosion-safe. Rollover of the LPESH prototypes was simulated during their testing but no irreversible consequences and malfunction were observed. Unlike an oil radiator, rollover does not cause the EH to ignite. Damage to the casing of the electrovacuum heater was simulated but no fire or explosion occurred.

---

### Acknowledgments

---

All studies presented in the article were carried out using materials and technical resources of the Kazakh Agrotechnical University named after S. Seifullin within the framework of the grant OK/00642 on the topic Energy-saving Electric Steam Heater of Negative Pressure under the program Development of Links Between Science and Industry and in the framework of the dissertation for a PhD degree at Karaganda Technical University NJSC.

---

### References

1. Parokapelnye nagrevateli. Available at: <http://vestkz.ru/opisanie.htm>
2. Espatolero, S., Romeo, L. M., Escudero, A. I., Kuivalainen, R. (2017). An operational approach for the designing of an energy integrated oxy-fuel CFB power plant. *International Journal of Greenhouse Gas Control*, 64, 204–211. doi: <http://doi.org/10.1016/j.ijggc.2017.07.018>
3. Taler, J., Trojan, M., Taler, D., Dzierwa, P., Kaczmarek, K. (2017). Improving flexibility characteristics of 200 MW unit. *Archives of Thermodynamics*, 38 (1), 75–90. doi: <http://doi.org/10.1515/aoter-2017-0005>
4. Piccolo, A., Pistone, G. (2006). Estimation of heat transfer coefficients in oscillating flows: The thermoacoustic case. *International Journal of Heat and Mass Transfer*, 49 (9-10), 1631–1642. doi: <http://doi.org/10.1016/j.ijheatmasstransfer.2005.11.009>
5. Wang, Y., Quan, Z., Jing, H., Wang, L., Zhao, Y. (2021). Performance and operation strategy optimization of a new dual-source building energy supply system with heat pumps and energy storage. *Energy Conversion and Management*, 239. doi: <http://doi.org/10.1016/j.enconman.2021.114204>
6. Zhang, Y., Xia, J., Fang, H., Zuo, H., Jiang, Y. (2019). Roadmap towards clean heating in 2035: Case study of inner Mongolia, China. *Energy*, 189. doi: <http://doi.org/10.1016/j.energy.2019.116152>
7. Wu, P., Wang, Z., Li, X., Xu, Z., Yang, Y., Yang, Q. (2020). Energy-saving analysis of air source heat pump integrated with a water storage tank for heating applications. *Building and Environment*, 180. doi: <http://doi.org/10.1016/j.buildenv.2020.107029>
8. Istoriya izobreteniya obogrevatelya. Available at: <https://tehnikaland.ru/klimaticheskaya-tehnika/istoriya-izobreteniya-obogrevatelya.html>
9. Obogrevateli: pozhnaya bezopasnost. Available at: <https://ogneza.com/obogrevateli-pozhnaya-bezopasnost.html>
10. Mekhtiev, A. D., Karpenko, A. N., Aldoshina, O. V., Yugay, V. V. (2015). Avtonomnye sistemy otopeniya novogo pokoleniya. Karaganda: Izd-vo KarGTU, 196.
11. Ventsel, E. S., Ovcharov, L. A. (2000). Teoriya veroyatnostey i inzhenernye prilozheniya. Moscow: Vysshaya shkola, 480. Available at: <https://may.alleng.org/d/math/math370.htm>
12. Dan, P. D., Rey, D. A. (1979). Teplovy truby. Moscow: Energiya, 272. Available at: [https://www.studmed.ru/dan-pd-rey-da-teplovy-truby\\_dd1b7abb9f1.html](https://www.studmed.ru/dan-pd-rey-da-teplovy-truby_dd1b7abb9f1.html)
13. Jouhara, H., Khordehghah, N., Almahmoud, S., Delpech, B., Chauhan, A., Tassou, S. A. (2018). Waste heat recovery technologies and applications. *Thermal Science and Engineering Progress*, 6, 268–289. doi: <http://doi.org/10.1016/j.tsep.2018.04.017>
14. Xu, X., Ju, G. D. (2019). Application and thermal economic analysis of plate low pressure economizer in flue gas waste heat recovery. *IOP Conference Series: Earth and Environmental Science*, 291. doi: <http://doi.org/10.1088/1755-1315/291/1/012025>
15. Radiator otopeniya (2018). Pat. No. 2816 RK. opubl. 24.04.2018.
16. Radiator otopeniya (2017). Pat. No. 32156 RK. opubl. 16.05.17.