

# IMPROVING THE UNIT FOR MELTING CHEESE MASSES

**Mariana Bondar**

*Corresponding author*

Assistant

Department of Food Technologies and Microbiology\*

E-mail: bondarmariana34@gmail.com

**Oksana Skoromna**

PhD, Associate Professor

Department of Livestock Production Technology\*

**Nataliia Ponomarenko**

PhD, Associate Professor\*\*

**Hennadii Tesliuk**

PhD, Associate Professor\*\*

**Iryna Honcharova**

PhD, Associate Professor

Department of Genetics, Breeding and

Breeding Technologies in Animal Husbandry

Institute of Veterinary Medicine

State Biotechnological University

Alchevskykh str., 44, Kharkiv, Ukraine, 61002

**Nataliia Nedosiekova**

PhD

Department of Animal Husbandry and Food Technologies

Luhansk National Agrarian University

Slobozhanska str., 68, Starobilsk, Ukraine, 92703

**Bohdan Shaferivskyy**

PhD, Associate Professor

Department of Small Animal Production

Poltava State Agrarian University

Skovorody str., 1/3, Poltava, Ukraine, 36003

**Ruslan Zakharchenko**

PhD

Department of Automatics, Electronics and Telecommunications

National University «Yuri Kondratyuk Poltava Polytechnic»

Pershotravnevyi ave., 24, Poltava, Ukraine, 36011

\*Vinnytsia National Agrarian University

Sonyachna str., 3, Vinnytsia, Ukraine, 21008

\*\*Department of Tractors and Agricultural Machines

Dnipro State Agrarian and Economic University

Serhiya Yefremova str., 25, Dnipro, Ukraine, 49600

*This paper reports the improved model of the unit for melting cheese masses. The device differs in the technique of heat supply to working tanks through the replacement of a steam jacket with heating by a flexible film resistive electric heater of radiative type (FFREhRT). The heat exchange surface of the working container was increased through heating the mixing device by FFREhRT. In addition, the unit is distinguished by utilizing secondary thermal energy of melting cheese masses (35...95 °C) by converting it with Peltier elements into a low-voltage power supply to autonomous fans (3.5...12 W) in order to cool the control unit. Such a solution would improve the efficiency of the proposed structure, which is explained by reducing the dimensional and weight parameters of the cheese melting unit by replacing the steam heating technique with an electric one.*

*A decrease in the time to enter a stationary mode (85 °C) when melting cheese masses was experimentally confirmed: for the bowl of the examined unit – 575 s, compared to the analog – 725 s. That confirms the reduction in the time to enter a stationary mode by 21 % compared to the base unit B6-OPE-400.*

*The estimation has established a 1.2-time decrease in the main indicator of resource efficiency of the specific energy consumption for heating the volume of a unit of product in the improved plant for melting cheese masses – 3,037.2 kJ/kg, compared to the base B6-OPE-400 – 3,672.5 kJ/kg. The results confirm an increase in resource efficiency that is achieved by the elimination of steam heat networks; the increased heat exchange surface of working bowls by heating the stirrer with the help of FFREhRT. The heat transfer that employs FFREhRT simplifies the operational indicators of the temperature stabilization system in the bowl of the cheese mass melting unit. The results reported here may prove useful when designing thermal equipment with electric heating while using secondary thermal energy*

*Keywords: cheese mass melting unit, heat supply, specific energy consumption, secondary energy*

Received date 19.10.2021

Accepted date 03.12.2021

Published date 28.12.2021

**How to Cite:** Bondar, M., Skoromna, O., Ponomarenko, N., Tesliuk, H., Honcharova, I., Nedosiekova, N., Shaferivskyy, B.,

Zakharchenko, R. (2021). Improving the unit for melting cheese masses. *Eastern-European Journal of*

*Enterprise Technologies*, 6 (11 (114)), 99–105. doi: <https://doi.org/10.15587/1729-4061.2021.246300>

## 1. Introduction

The increased demand for a balanced diet in many countries necessitates providing the body with functional and physiological ingredients to stay healthy and strengthen immunity, as well as the high-quality resistance to environmental and pandemic factors. In particular, dairy products

with a high content of biologically active and mineral substances are important for the health of the body and must certainly be consumed in a full diet, regardless of the age of consumers [1]. This approach leads to the need to provide consumers with the necessary plant nutrients to maintain and promote health in the form of quality dairy products of natural origin.

Among the favorite dairy products are a variety of processed cheeses whose production involves rennet cheeses and different cheese products, etc., which require high-quality heat and mass exchange processing during production. Therefore, it is advisable to ensure resource-efficient processing of dairy raw materials into processed cheese products in compliance with formulation ratios, stabilized heat exposure, and the use of secondary thermal energy for technological needs. The introduction in the formulation of processed cheeses of organic plant-based semi-finished products in pasty, powdered, etc. consistency provides for the additional enrichment of products with functional and physiological ingredients, increasing nutritional value and forming original organoleptic properties [2, 3].

The efficiency of the manufacturing complex for processed cheeses depends on the quality of heat and mass exchange treatment, in particular melting operations, requiring the implementation of modern engineering solutions to ensure the resource efficiency of processes. One solution is to reduce the metal consumption for cheese melting devices by eliminating the steam component and ensuring stabilized low-inertial temperature effect by modern electric heat carriers. In addition, an appropriate solution is to ensure the use of secondary thermal energy for the needs of production (autonomy of certain structural elements, cooling, etc.). Introduction and implementation of such effective hardware and technological solutions is a relevant task that would lead to the execution of high-quality heat and mass transfer process. The result of improving the structure of the unit for the production of processed cheeses could reduce the hardware cost, simplify operation, and improve the competitiveness of products.

---

## 2. Literature review and problem statement

---

Paper [4] specifies the percentage of consumers who lead a healthy lifestyle with the formation of strong immunity in a pandemic, various health defects, and environmental challenges. The research was implemented at the online platform built at the beginning of the COVID-19 pandemic to promote the ethics of nutrition, cooking, and consumption at home. The introduction of IT technologies under quarantine is an effective solution but it is aimed at using semi-finished products in most cases since preparing high-quality food products at home is a difficult task. Study [5] focuses on the uncertainty of the pandemic of the new coronavirus caused by COVID-19 but clinical observations indicate the decisive role of innate and acquired immunity. Promoting a healthy lifestyle could ensure an increase in innate immunity through functional food and high-readiness organic semi-finished products, and is a rational strategy to minimize the harm caused to health by viruses. However, attention is not paid to the need to ensure high-quality health and prophylactic nutrition although this is a priority for the food industry, due to the need to improve manufacturing systems to ensure the efficiency of production in general. Paper [6] notes the demand for plant-based diets to strengthen health, in particular, various commercially successful plant-based dairy and meat products are being designed. However, the production of such foods is a complex technological and equipment component, which greatly affects the quality of the resulting dairy products. This is due to the fact that the process of making cheese and other foodstuffs in most cases

is executed through heat and mass exchange operations that require a strict stabilization of temperature exposure. At the same time, modern ways of ensuring high-quality heat and mass exchange processes characterized by resource efficiency remain to be studied, which, therefore, makes them the relevant scientific and practical areas of research.

In [7], the research aims to determine and confirm the increase in the nutritional value of processed cheeses when adding various vegetable powders to their formulation. It was established that the change in the proportion of natural functional and physiological composition can adjust the resulting structural-mechanical, organoleptic, etc. properties; however, only the technological component of the process is considered. Because most industries use hardware systems that are not able to fully ensure the appropriate level of processing quality and do not have sufficient resource efficiency. This is due in most cases to the use of intermediate heat carriers, artificially increased metal intensity of equipment for the heat and mass exchange melting operations, confirming the relevance of research into this area. Thus, work [8] reports data on the integrated combination of design and modeling processes for cheese production to improve the environmental and economic indicators in the industry. A given model makes it possible to take into consideration the prospects of production and resulting consumption based on phased consideration. Much attention is paid in the model to ways to improve the technological process, ensure energy efficiency, and even the cost of waste, but the model does not take into consideration the overall efficiency as a result of improving the equipment component of the process. This is due to the rapid development of modern technologies to improve the existing heat and mass exchange systems, ensuring the efficiency of the process in general, for example by eliminating steam systems, reducing waste, using secondary thermal energy, etc.

Paper [9] reports a study into determining the effects of deformation in the range of 0.196...359 % and temperature on the obtained structural and mechanical properties of various cheeses; stickiness analysis has made it possible to obtain information about adhesion properties. The study results confirmed an increase in the rate of cheese melting depending on the temperature; at the same time, adhesion properties are reduced, and, therefore, the necessary energy for the heat and mass exchange process is reduced. The authors of work [10], in order to determine the effectiveness of cheese melting, apply computer technologies to analyze the effect of duration (0–20 min) and temperature (70–200 °C) on the degree and speed of cheese melting. It was found that cheddar and mozzarella cheeses melt rapidly at the initial cooking stage; melting slows down after about 3–4 minutes. The maximum degree and melting speed were observed at a temperature of about 130–160 °C but prolonged cooking at high temperatures led to a decrease in melting. However, the cited works do not specify the effect exerted by the heat supply technique as one of the main factors in the efficiency of the process in general; this is due to the use of conventional equipment, which in most cases uses steam intermediate heat carriers. Consequently, the equipment efficiency of the devices is debatable since the consumption of energy for melting affects the received quality and ultimate cost of products, which renders relevant the research aimed at improving resource efficiency.

Therefore, to fully analyze the production of processed cheeses, the integrated impact of the equipment and tech-

nological component should be taken into consideration, which could ensure the efficiency of the equipment, as well as competitiveness and high manufacturing quality. Increasing nutritional value is possible due to the introduction of modern technologies and methods of processing organic raw materials as a natural source of functional and physiological ingredients in the production of semi-finished products of a high degree of readiness [11]. Conventional units that produce processed cheeses are characterized by the use of steam heat carriers and the possibility of steam entering a working container during heat and mass exchange treatment [12]. The disadvantage of steam entering the working space of the unit is the need to clean it three times, while the use of steam leads to an artificial increase in metal consumption, and, therefore, complicates the operation, maintenance, and cost of the equipment and technological component. Therefore, it will be important to implement innovative solutions aimed at improving the unit for the production of high-quality processed cheeses. It should be noted that the issues regarding ways to increase resource efficiency by reducing metal consumption during the liquidation of the steam component remain fully uncertain. Steam jackets were replaced with electric heating in work [13] using an example of an improved design of the rotary evaporator; however, questions remain about the effect of the heat supply technique on hydrodynamic properties. Work [14] also considers the effectiveness of the use of electric heating when post-drying the pre-concentrated food raw materials. However, the cited work does not define the effect of the thermal-radiation component of the heat and mass exchange process in combination with convective; in particular, there is a need to analyze the absorbing properties of raw materials being processed. It is also advisable to determine the effectiveness of the use of mixer structures with a heating surface as one of the solutions to replace the need for steam to enter the working capacity of the unit. Electric heating of the working tank and the stirrer surface with a modern flexible film resistive electric heater of radiative type (FFREhRT) [15] could ensure a decrease in metal consumption, as well as the stabilized and low-inertia temperature heating compared to the conventional unit [16]. Work [17] reports a study into the processes of heat transfer and electrical conductivity of thermoelectric generators when analyzing the efficiency of Peltier elements based on 127 thermocouples. Because of the Peltier effect and the heat flow, the equivalent thermal conductivity increases by 30.2 % when the temperature difference between the hot and cold sides is 100 °C, and the thermoelectric generator reaches the maximum output power. However, the research is based only on the use of convective heat transfer, which makes it difficult to prove the effectiveness of the use of Peltier elements in mixed heat supply. Thus, paper [18] reports a study into the effectiveness of the use of Peltier elements in a low-temperature heat and mass exchange unit; however, only the initial and final parameters of ensuring the autonomy of exhaust elements are specified. Without defining the influence of the convective component in the heat treatment of experimental raw materials, the cited studies, however, confirm the effectiveness of the use of Peltier elements when converting secondary energy into a low-voltage power supply to fans, which ensures their autonomy. The reported scientific and practical results would be characterized by a positive impact exerted on the effectiveness of the heat and mass transfer process of cheese melting, and, therefore, could ensure the competitiveness of the products to be obtained, thereby confirming the feasibility of research in this area.

---

### 3. The aim and objectives of the study

---

The purpose of this work is to improve the unit for melting cheese masses where the working surface and the stirrer are heated by a flexible film resistive electric heater of radiative type, involving a cooling jacket and Peltier elements. The proposed equipment and technological solution would ensure the improvement of the efficiency of the manufacturing process in general by eliminating the steam component of the classic cheese melting techniques while using secondary thermal energy.

To achieve the set aim, the following tasks have been solved:

- to design a model structure of the improved unit for melting cheese masses where the working surface and the stirrer are heated with a flexible film resistive electric heater of radiative involving a cooling jacket and Peltier elements;
- to determine by experimental and calculation studies and confirm the effectiveness of the proposed structural-technological solutions in comparison with the classic structures of devices for making processed cheeses.

---

### 4. The study materials and methods

---

Our scientific and practical studies made use of the Research Center “Newest Biotechnology and Equipment for the Production of Food Products with High Wellness Properties” at the State Biotechnological University (Ukraine).

We have improved a model structure of the unit for melting cheese masses where the working surface and the stirrer are heated with a flexible film resistive electric heater of radiative type involving a cooling jacket with Peltier elements. The structure makes it possible to investigate rational heat and mass exchange modes, taking into consideration the influence of the heat supply technique on the dynamics of entering the stationary mode, which, in turn, would ensure the smooth melting of the cheese mass. The structural-technological solutions proposed for the unit could be used for grinding, mixing, heat and mass exchange treatment, for example, dairy products (desserts, mousses, etc.), minced meat, pate, etc.

We compared the characteristics of the improved model structure of the unit for melting cheese masses and the conventional unit (B6-OPE-400, Ukraine [19]) according to the procedures for the thermal calculation of devices and the experimental procedure using the measuring devices “OVEN” (Ukraine).

---

### 5. Results of the experimental and estimation studies of the improved unit for melting cheese masses

---

#### 5.1. Design of an improved model of the unit for melting cheese masses

The improved model of the unit for melting cheese masses is shown in Fig. 1. The unit is mounted on bed 1, which is designed to enable the circular motion of bowls for melting mounted on wheels 2. The melting bowls and the surface of blade mixer 4 are heated in stages by a flexible film resistive electric heater of radiative type (FFREhRT) 3 with a thermally-insulating outer surface.

For the additional grinding of cheese masses, the lower part of the blade stirrer is equipped with a fixed cutter knife 5,

providing for a homogeneous grinding of the cheese fraction. At the bottom of the bowls for melting cheese masses, there is an unloading nozzle 6 with an autonomous valve, which makes it possible to further transport raw materials according to technological needs. In order to ensure the cooling of the cheese mass, the bowl is equipped with cooling jackets 7 with a coil heat exchanger; during the melting process, there is air in jacket 7, providing for additional thermal insulation of the heat and mass exchange process.

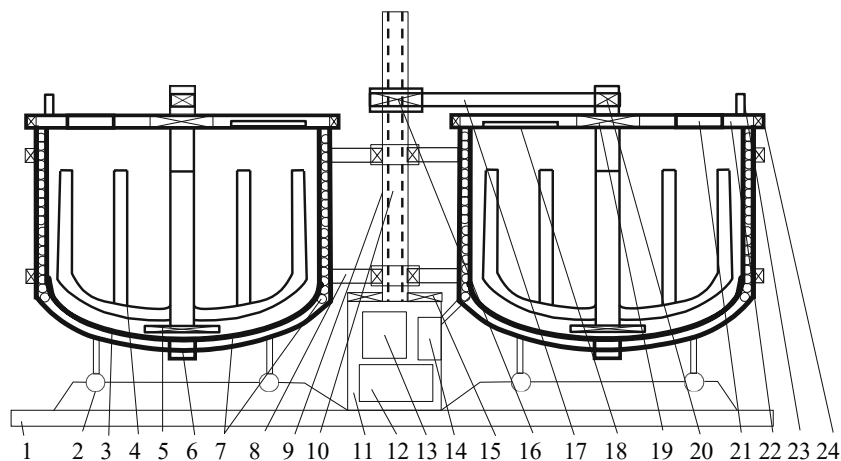

Fig. 1. Diagram of the improved model structure of the unit for melting cheese masses: 1 – bed; 2 – wheels for the rotational movement of bowls; 3 – flexible film resistive electric heater of radiative type (FFREhRT) with a thermally-insulating outer surface; 4 – blade mixer with FFREhRT; 5 – cutter knife; 6 – unloading nozzle for processed cheese with a valve; 7 – cooling jacket with a coil heat exchanger; 8 – rotary guides for bowls; 9 – technical casing; 10 – rotation shaft and internal latch rail; 11 – control unit; 12 – motor compartment; 13 – control unit of technological parameters; 14 – water ring pump; 15 – autonomous fans; 16 – elastic bushing-finger coupling; 17 – gear rail; 18 – Peltier elements; 19, 20 – clutch; 21 – loading hopper; 22 – cover; 23 – vacuum connection nozzle; 24 – cover seal

The structure is equipped with an innovative control complex 11, which hosts engine compartment 12 with a three-speed electric motor. The control unit of technological parameters 13 makes it possible to control the temperature of FFREhRT and the technological mass, the frequency of rotation of the stirrer, the opening of the valve of unloading nozzle 6. The system has a water ring pump 14, which, if necessary, implements the cooling process by enabling the injection of liquid into cooling jacket 7 with a ring heat exchanger. Due to the use of FFREhRT, as well as its low metal consumption and low inertia, in contrast to networks based on steam heat supply, rapid cooling of technological raw materials is ensured. System 11 is connected to technical casing 9, inside which there is rotary shaft 10 to transmit the rotation of blade mixer 4 through elastic ferrule-finger coupling 16, which is connected by gear rail 17 to the stirrer. The proposed technical solution makes it possible to rotate stirrer 4 at a frequency of 85, 120, and 180  $\text{min}^{-1}$ , thereby implementing a high-quality process of cheese mass melting. To lift cover 22 with seals 24 and a secured blade stirrer 4, the structure of rotation shaft 10 includes an internally placed latch rail. To gradually change the bowls for melting cheese masses, technical casing 9 hosts rotating guides 8 for bowls, thereby allowing the developed machine to work in stages with two bowls placed on bed 1.

To prevent the overheating of control unit 11, the structure of lid 22 hosts the Peltier elements 18, which make it possible to convert the secondary thermal energy of melt-

ing (35...95 °C) into a low voltage power (3.5...12 W). This energy is enough for the autonomous operation of exhaust fans 15 located at the top of system 11. And, for the heat and mass exchange processes under vacuum, the improved structure has a vacuum connection nozzle 23.

The melting of cheese masses is implemented as follows: the pre-crushed raw materials, through hopper 21, are loaded into the working space of the bowl, then the control unit 11 is enabled, thereby setting the necessary technological and equipment parameters, in particular, FFREhRT 3, and blade stirrer 4. The heating is enabled with subsequent final grinding by cutter knives 5 and melting of the cheese mass to 85...90 °C for 15...20 minutes if necessary. To remove a specific smell from raw materials when melting, a vacuum of 40...50 kPa is connected to the unit through nozzle 23. The unit is unloaded through lower nozzle 6 with an automatic valve, by lifting lid 22 with blade stirrer 4 and moving the next bowl to repeat the process. The used bowl is sent for sanitation and cleaning.

## 5.2. Experimental and estimation studies into the impact of the proposed structural-technological solutions on the process efficiency

Our experimental study into the process of cheese mass melting involving the experimental unit aimed to establish the basic parameters of the process to obtain initial data in order to further calculate the device. The transitional characteristic of heating a working container (bowl) when melting cheese masses is shown in Fig. 2.

The comparative analysis of the heating of cheese mass in bowls confirms the effectiveness of the proposed structural and technical solutions to reduce the metal consumption by the working bowl and increase the heat exchange surface when heating the stirrer using FFREhRT. The time for the experimental unit for melting cheese masses to enter a stationary mode (85 °C) is 575 s; in the analog, this figure is 725 s. That provides for a reduction in the time to enter the stationary mode by the experimental unit by 21 % compared to the base B6-OPE-400.

Therefore, the decrease in the melting time of cheese masses due to the increase in efficiency with a decrease in metal consumption and an increase in the heat transfer surface is confirmed.

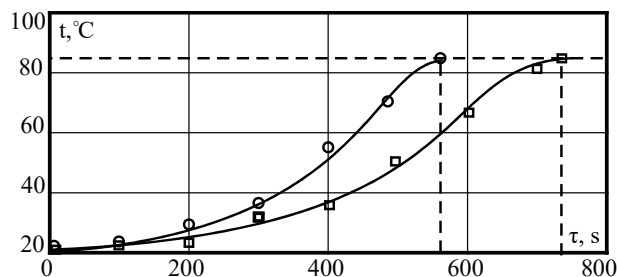

Fig. 2. Transitional characteristics of heating the cheese mass in bowls: ○ – experimental unit; □ – B6-OPE-400

To determine the effectiveness of the improved model unit for cheese mass melting, its characteristic is given in comparison with the base structure B6-OPE-400. The calculations were carried out without taking into consideration losses to the environment (Table 1).

The practical implementation of the proposed structural-technological solutions would provide high-quality heat and mass exchange treatment. We have established the reduction of metal consumption of the working bowl due to the elimination of steam heating while increasing the heat transfer surface under when heating the stirrer with FFREhRT. In particular, the time to enter the stationary mode (85 °C) by devices for melting cheese masses is 575 s in the experimental bowl, compared to 725 s in the analog (Fig. 2: experimental study). That ensured a 21 % reduction in the time to enter a stationary mode compared to the base B6-OPE-400. Based on the obtained technical characteristics for the improved model unit for the melting of cheese masses, in comparison with the base structure B6-OPE-400, we have determined a 1.2-time decrease in the specific energy consumption for heating the volume of the product unit. Thus, in the improved unit for melting cheese masses, this indicator is 3037.2 kJ/kg, and in the base B6-OPE-400 – 3672.5 kJ/kg (Table 1). Experimentally and practically, we established a decrease in the duration of heating the unit to the technological melting point (85 °C); in particular, for the experimental unit – 568 s, for the conventional unit – 720 s (Table 1). Thus, it reduces the duration of heat treatment of cheese masses, and, therefore, generally indicates an increase in the efficiency of the heat and mass transfer process. A characteristic feature, compared to existing technological and equipment analogs of the units for melting cheese masses based on classic devices with a steam component, is the absence of a heated stirrer and the introduction of steam into working volume, reducing the efficiency of the process [20].

Table 1

Comparative characteristics of the improved unit compared to the base structure B6-OPE-400

Energy loss	B6-OPE-400	Improved unit
Unit weight	$M^*=3,700$ kg	$M=1,150$ kg
Working container weight	$m_1^*=350$ kg	$m_1=140$ kg
Specific cost	$Q_{sp}=Q/m_{pr}=36,725/100=-3,672.5$ kJ/kg	$Q_{sp}=Q/m_{pr}=30,372/100=-3,037.2$ kJ/kg
Heating duration	$\tau=Q/F^* \cdot k \cdot \Delta t=32,357/0.75 \cdot 921 \cdot 65=720$ s	$\tau=Q/F \cdot k \cdot \Delta t=32,357/0.95 \cdot 921 \cdot 65=568$ s
Working container's heat exchange surface area	$F^*=0.75$ m <sup>2</sup>	$F=F^*+F_{st}=0.75+0.20=0.95$ m <sup>2</sup>
Heating the working container for cheese melting	$Q_{heat} = m_1 \cdot c \cdot (t_2' - t_1') + m_2 \cdot c \cdot (t_2'' - t_1'') = 210 \cdot 0.48(85 - 20) + 140 \cdot 0.48(85 - 20) = 6,552 + 43,68 = 10,920$ kJ	$Q_{heat} = m_1 \cdot c \cdot (t_2' - t_1') = 210 \cdot 0.48(85 - 20) = 6,552$ kJ
Product heating	$Q_{pr}=m_{pr} \cdot c \cdot (t_k - t_n) = 100 \cdot 3.97 \cdot (85 - 20) = 25,805$ kJ	$Q_{pr}=m_{pr} \cdot c \cdot (t_k - t_n) = 100 \cdot 3.97 \cdot (85 - 25) = 23,820$ kJ
Total	$Q_{tot}=36,725$ kJ	$Q_{tot}=27,276$ kJ
Unit specific metal consumption	$m=M^*/F=3,700/1.5=2467$ kg/m <sup>2</sup>	$m=M/F=1,150/1.9=605$ kg/m <sup>2</sup>

Note: \* – comparative data on the base structure B6-OPE-400 are taken from [19]

We have established a 1.2-time decrease in the main indicator of resource efficiency of specific energy consumption for heating the volume of a unit of product in the improved unit for melting cheese masses: experimental – 3037.2 kJ/kg, base B6-OPE-400 – 3672.5 kJ/kg (Table 1). The effect is explained by a decrease in the dimensional-weight parameters of the unit for melting cheese masses (the absence of steam heat networks, etc.), as well as a reduction in the duration of heating the unit to the predefined temperature (85 °C). The prototype unit – 568 s, and in the conventional one – 720 s, thereby ensuring a decrease in the duration of temperature effect during the time of cheese melting, thereby improving the efficiency of the heat and mass transfer process.

**6. Discussion of the established indicators of efficiency of structural solutions in the improved unite for melting cheese masses**

The reported practical and experimental comparative studies into the improved unit for melting cheese masses, in which the working surface and the stirrer (are heated by FFREhRT equipped with a cooling jacket and Peltier elements (Fig. 1), confirm the effectiveness of its industrial application. Using FFREhRT for heating, given its low metal consumption and low inertia, in contrast to networks based on steam heat supply, provides, if necessary, rapid cooling of technological raw materials. In this case, the arrangement in the system (pos. 11, Fig. 1) of water ring pump 14 enables the injection of liquid into cooling jacket 7 with a ring heat exchanger. To prevent the overheating of control system 11, the structure of lid 22 hosts the Peltier elements 18 to convert the secondary thermal energy of melting (35...95 °C) into low voltage power (3.5...12 W) for autonomous exhaust fans.

One of the main limitations in the melting of cheese masses is the stabilization of temperature influence depending on technological needs and formulation composition. To resolve it, as an option, there is a need to use low-inertial and metal-free heaters, in particular, FFREhRT, taking into consideration the temperature range for high-quality heat and mass exchange treatment of the formulation composition. Further research could aim at determining the rational melting regimes for cheese masses whose formulations include the functional and physiological ingredients of organic origin (pastes, powders, lactic- and bifidobacterial, etc.) [21, 22]. This, in turn, would increase the nutritional value of the products with original organoleptic properties, ensuring the competitiveness of the products received for health and prophylactic purposes, which is relevant in the context of environmental and pandemic challenges of today.

**7. Conclusions**

1. We have improved a model of the unit for melting cheese masses, which is distinguished by the technique of heat supply to working tanks and by heating the stirring device with a flexible film resistive electric heater of radiative

type (FFREhRT) with a thermally-insulating outer surface. In addition, the unit is distinguished by the use of secondary thermal energy of melting (35...95 °C) by converting it with the Peltier elements into a low-voltage power (3.5...12 W) for autonomous fans to cool the control unit.

2. We have experimentally confirmed a decrease in the time to enter a stationary mode (85 °C) when melting cheese masses: for a bowl in the experimental unit – 575 s, compared to that of the analog, 725 s. Thus, the duration of entering the stationary mode is reduced by 21 % compared to the base device B6-OPE-400. By estimation, a 1.2-time decrease in the specific energy consumption was determined, for heating the volume of a unit of product in the improved unit for melting cheese masses – 3037.2 kJ/kg, while in the base B6-OPE-400 – 3672.5 kJ/kg. The increase in the efficiency of

the proposed structure of the experimental unit is explained by a decrease in the dimensional-weight parameters (the absence of steam heat networks, etc.), energy-metal consumption, and by an increase in the heat exchange surface of working bowls, due to the stirrer heated with FFREhRT.

---

### Acknowledgments

---

This study was carried out in the framework of the State budget theme No. 1-21 BO “Development of technological processes and low-temperature equipment for the production of multifunctional semi-finished products and confectionery using organic raw materials” under the guidance of Associate Professor Andriy Zagorulko.

---

### References

1. Guinee, T. P. (2022). Cheese as a Food Ingredient. *Encyclopedia of Dairy Sciences*, 56–69. doi: <https://doi.org/10.1016/b978-0-12-818766-1.00082-9>
2. Broome, M. C., Powell, I. B. (2022). Starter Cultures: Specific Properties. *Encyclopedia of Dairy Sciences*, 367–375. doi: <https://doi.org/10.1016/b978-0-12-818766-1.00202-6>
3. Kiptelaya, L., Zagorulko, A., Zagorulko, A. (2015). Improvement of equipment for manufacture of vegetable convenience foods. *Eastern-European Journal of Enterprise Technologies*, 2 (10 (74)), 4–8. doi: <https://doi.org/10.15587/1729-4061.2015.39455>
4. Antine, S., L'Horset, A. M., Heiden, P., Salazar, G. (2020). Experiential children's nutrition education: Growing strong bodies and healthy minds. *EXPLORE*, 16 (5), 340–341. doi: <https://doi.org/10.1016/j.explore.2020.06.007>
5. Han, B., Hoang, B. X. (2020). Opinions on the current pandemic of COVID-19: Use functional food to boost our immune functions. *Journal of Infection and Public Health*, 13 (12), 1811–1817. doi: <https://doi.org/10.1016/j.jiph.2020.08.014>
6. Grossmann, L., McClements, D. J. (2021). The science of plant-based foods: Approaches to create nutritious and sustainable plant-based cheese analogs. *Trends in Food Science & Technology*, 118, 207–229. doi: <https://doi.org/10.1016/j.tifs.2021.10.004>
7. Farahat, E. S. A., Mohamed, A. G., El-Loly, M. M., Gafour, W. A. M. S. (2021). Innovative vegetables-processed cheese: I. Physicochemical, rheological and sensory characteristics. *Food Bioscience*, 42, 101128. doi: <https://doi.org/10.1016/j.fbio.2021.101128>
8. Gosalvitir, P., Cuéllar-Franca, R. M., Smith, R., Azapagic, A. (2021). Integrating process modelling and sustainability assessment to improve the environmental and economic sustainability in the cheese industry. *Sustainable Production and Consumption*, 28, 969–986. doi: <https://doi.org/10.1016/j.spc.2021.07.022>
9. Yildirim-Mavis, C., Ozmen, D., Yakisik, E., Toker, O. S., Palabiyik, I., Kaner, O. (2021). Evaluation of kashar cheese meltability by tack and large amplitude oscillatory shear (LAOS) tests. *International Dairy Journal*, 105242. doi: <https://doi.org/10.1016/j.idairyj.2021.105242>
10. Wang, H. (2002). Melting characteristics of cheese: analysis of effects of cooking conditions using computer vision technology. *Journal of Food Engineering*, 51 (4), 305–310. doi: [https://doi.org/10.1016/s0260-8774\(01\)00072-3](https://doi.org/10.1016/s0260-8774(01)00072-3)
11. Mykhailov, V., Zahorulko, A., Zagorulko, A., Liashenko, B., Dudnyk, S. (2021). Method for producing fruit paste using innovative equipment. *Acta Innovations*, 39, 15–21. doi: <https://doi.org/10.32933/actainnovations.39.2>
12. Vedischev, S. M. (2005). *Tehnologii i mehanizaciya pervichnoy obrabotki i pererabotki moloka*. Tambov: TGTU, 101.
13. Zahorulko, A., Zagorulko, A., Yancheva, M., Ponomarenko, N., Tesliuk, H., Silchenko, E. et. al. (2020). Increasing the efficiency of heat and mass exchange in an improved rotary film evaporator for concentration of fruit-and-berry puree. *Eastern-European Journal of Enterprise Technologies*, 6 (8 (108)), 32–38. doi: <https://doi.org/10.15587/1729-4061.2020.218695>
14. Cherevko, O., Mikhaylov, V., Zahorulko, A., Zagorulko, A., Gordienko, I. (2021). Development of a thermal-radiation single-drum roll dryer for concentrated food stuff. *Eastern-European Journal of Enterprise Technologies*, 1 (11 (109)), 25–32. doi: <https://doi.org/10.15587/1729-4061.2021.224990>
15. Zahorulko, A. M., Zahorulko, O. Ye. (2016). Pat. No. 108041 UA. Hnuchkyi plivkovyi rezystyvnyi elektronahrivach vyprominiuchoho typu. No. u201600827; declared: 02.02.2016; published: 24.06.2016, Bul. No. 12. Available at: <https://uapatents.com/5-108041-gnuchkijj-plivkovijj-rezistivnijj-elektronagrivach-viprominyuyuchogo-tipu.html>
16. Tekhnologiya proizvodstva plavlennogo syra. Available at: <https://www.kaspiko.com/index.php/evrika/tehnologii/item/273-%D1%82%D0%B5%D1%85%D0%BD%D0%BE%D0%BB%D0%BE%D0%B3%D0%B8%D1%8F-%D0%BF%D1%80%D0%BE%D0%B8%D0%B7%D0%B2%D0%BE%D0%B4%D1%81%D1%82%D0%B2%D0%B0-%D0%BF%D0%BB%D0%B0%D0%B2%D0%BB%D0%B5%D0%BD%D0%BD%D0%BE%D0%B3%D0%BE-%D1%81%D1%8B%D1%80%D0%B0>

17. Liao, M., He, Z., Jiang, C., Fan, X., Li, Y., Qi, F. (2018). A three-dimensional model for thermoelectric generator and the influence of Peltier effect on the performance and heat transfer. *Applied Thermal Engineering*, 133, 493–500. doi: <https://doi.org/10.1016/j.applthermaleng.2018.01.080>
18. Zahorulko, A., Zagorulko, A., Yancheva, M., Serik, M., Sabadash, S., Savchenko-Pererva, M. (2019). Development of the plant for low-temperature treatment of meat products using ir-radiation. *Eastern-European Journal of Enterprise Technologies*, 1 (11 (97)), 17–22. doi: <https://doi.org/10.15587/1729-4061.2019.154950>
19. Kotel plavitel' B6-OPE-400. Available at: <https://kh.agrotorg.net/ru/board/m-407878/kotel-plavitel-b6-ope-400/>
20. Tehnologiya proizvodstva plavlennogo syra i harakteristika tehnologicheskogo oborudovaniya. Available at: <http://www.milkbranch.ru/publ/view/340.html>
21. Solomon, A., Bondar, M., Dyakonova, A. (2019). Substantiation of the technology for fermented sour-milk desserts with bifidogenic properties. *Eastern-European Journal of Enterprise Technologies*, 1 (11 (97)), 6–16. doi: <https://doi.org/10.15587/1729-4061.2019.155278>
22. Kaletnik, H., Lutsiak, V., Melnichuk, O., Dovhan, Y., Malicki, M. (2019). Organizational basis of the development of innovative functional food products by the Ukrainian enterprises of deep walnut processing. *Ukrainian Food Journal*, 8 (1), 169–180. Available at: <https://ir.vtei.edu.ua/g.php?fname=26328.pdf>