

Power systems are usually expected to become heavily loaded as the demand for electrical energy grows and economic consideration limits the installation of additional transmission and generating capacity. Keeping the bus voltage in the power system within the standard permissible limits is an important concern to improve the voltage stability and avoid voltage collapse of the whole power system. The common and effective way to achieve this purpose is by adding flexible AC transmission line devices to the power system. One of these devices is static synchronous compensator. In this paper an approach is proposed to find optimal location and size of static synchronous compensator for improving bus voltage in the power system. A load flow is conducted to identify the low voltage buses which are the weak buses in the system and they are considered as suitable buses for static synchronous compensator connection. An objective function is formulated for optimization process which contains four parts, the voltage deviation, static synchronous compensator size, active and reactive power losses of the whole power system. Whale optimization algorithm is used for the optimization process. The proposed approach is applied on the real power system of Kurdistan Region using power system simulator for engineering software for simulating the power system and finding the optimal size and location of static synchronous compensator for bus voltage improvement. The results are encouraging for applying the approach to any power system. What distinguishes this method is that it accomplishes two things, namely reducing the bus voltage deviation to zero which means that all bus voltages are within the permissible limits and minimizing losses as well

Keywords: voltage stability, voltage improvement, static synchronous compensator, whale optimization algorithm

UDC 321.3

DOI: 10.15587/1729-4061.2022.251760

DETERMINATION OF OPTIMAL SIZE AND LOCATION OF STATIC SYNCHRONOUS COMPENSATOR FOR POWER SYSTEM BUS VOLTAGE IMPROVEMENT AND LOSS REDUCTION USING WHALE OPTIMIZATION ALGORITHM

Ali Abdulqadir Rasool

Corresponding author

Master of Science in Electrical Engineering*

E-mail: ali.rasool@su.edu.krd

Najimaldin M. Abbas

Assistant Professor

Department of Electrical Engineering

College of Engineering

University of Kirkuk

Baghdad str., Kirkuk, Iraq, 36001

Kamal Sheikhyounis

Assistant Professor*

*Department of Electrical Engineering

College of Engineering

University of Salahaddin-Erbil

Kirkuk Road, Erbil, Iraq, 44001

Received date 06.01.2022

Accepted date 18.02.2022

Published date 25.02.2022

How to Cite: Rasool, A. A., Abbas, N. M., Sheikhyounis, K. (2022). Determination of optimal size and location of static synchronous compensator for power system bus voltage improvement and loss reduction using whale optimization algorithm. *Eastern-European Journal of Enterprise Technologies*, 1 (8 (115)), 26–34. doi: <https://doi.org/10.15587/1729-4061.2022.251760>

1. Introduction

Electrical Power systems are complex because they have many generating units and transmission lines. Day by day the power demand increases as a result of that the utilities operate the generating units and transmission lines at their full capacity. This reduces power system stability in terms of bus voltage. Using the Flexible AC Transmission System (FACTS) in the transmission network improves the voltage stability, and also controls active and reactive power flow in the network [1]. Line power flow, bus voltage magnitudes and angles are controlled by using FACTS devices such as Static Synchronous Compensator STATCOM [2]. Because of the increasing power demand and inability to add new transmission lines due to their complexity, new power systems are operating close to the system stability limits.

Power system operating under such conditions introduces the voltage instability problem which may cause complete system blackout or voltage collapse which is the process of sequential events in a large area of the system and may lead to the case of severe low voltage condition in the system. Load increasing may lead to extreme need of reactive power and system may show voltage instability. If there is a deficiency in the reactive power resources, the excessive demand of reactive power can cause voltage collapse [3]. Such abnormal condition poses a great threat to the stability and reliability of power system. So voltage stability is identified as one of the main concerns in planning and operations of power system [4]. Transformers, transmission lines, cables, and other load appliances, like motors, change the relationship between current and voltage because of their fundamental characteristics. This shift is assessed in volt-ampere reac-

tive or VAR. High VAR can result in the decrease of power transfer. Low VAR can result in voltage drop. Thus, enough levels of reactive power are to be kept for voltage stability improving [5]. Therefore, studies that are devoted is to provide the required amount of reactive power for improving bus voltages and avoiding voltage collapse by using different approaches scientific relevance.

2. Literature review and problem statement

Many works have been carried out about the optimal size and location of FACTS devices to improve the voltage stability, minimize transmission line losses and avoid voltage collapse. In [6] Static VAR Compensators (SVCs) in transmission lines are used to maximize load margin. For deciding the actual SVCs placement, nonlinear programming is used. The main feature of this work is that it is a novel technique and is tested on real power system which means the possibility of application on any power system. The existence of many local minimal points is observed, it takes time for computation, but it is easy for implementation. In [7] optimal FACTS location, reducing the generation cost and increasing power transfer are obtained by using genetic algorithm technique. This approach mainly focuses on optimal load flow and minimizing the cost. It is tested only on IEEE 14-Bus system only. In [8] power system stability is considered as an index for optimal size of FACTS device controller. Model analysis and genetic algorithm is used, SVCs are used to find the best allocation. In this study three SVCs are used with optimal size and location. The study is mainly about the voltage stability of the system. In [9] Voltage stability is enhanced by optimizing FACTS device parameters, improving voltage profile, minimizing system losses and reactive power required for stability improvement. Particle Swarm Optimization (PSO) is used to optimize the location and size of STATCOM devices. The optimization includes the minimum total losses, minimum transfer of reactive power and maximizing the stability limits. The applicability of the method is tested on IEEE 30-Bus system only In [10] STATCOM modeling in power system is presented. Three kinds of PI controller are compared. The results are acceptable. The main advantage of this method is the linear behavior of the response of STATCOM which provides a linear range of the design. For testing the method, IEEE 118-Bus system is used. In [11] a new method is proposed for FACTS placement and applied on 9 IEEE-Bus, 39 IEEE-Bus and 68 IEEE-Bus systems. The best location of FACTS device is obtained from the view point of voltage stability. Power flow is conducted into two directions from sending to receiving end and from receiving to sending end to identify critical lines and buses. In general this method gives an accurate decision for FACTS placement. In [12] an approach for control of steady state power flow through FACTS provided to the power system is explained. Limits of these FACTS device are considered. This approach is applied on 1500-bus practical system with different types. The obtained results showed the effectiveness of the approach. This method is simple for implementation, but dealing with the control problem when numerous FACTS devices are involved is challenging.

In [13] improved voltage stability index is proposed and an optimization technique is presented for reactive power compensation device parameters. The obtained results show the effectiveness of the approach to improve voltage stabil-

ity and reduce transmission line losses. The performance of the approach is tested on IEEE 30-Bus system only. In [14] analysis for IEEE-14 bus is presented by identifying the weakest bus in the system and using conventional methods to study the voltage stability. Shunt Capacitor, Synchronous Condenser, and STATCOM were tested using P-V and Q-V analysis to identify the weak zones. Using shunt capacitor for stability improvement is excluded due to insufficient voltage control. STATCOM perform is better however, as these devices are more costly than shunt capacitors, a complete cost analysis study for their size is necessary.

One of the main problems which need to be taken into consideration is the voltage stability of the power system to ensure that the system can tolerate disturbances and keep the voltages within the allowed range. Reactive power imbalance is the most common cause of voltage instability [15]. The reactive power support that a bus can receive from the power system determines its load capability in the power system. Both active and reactive power losses grow fast as the system approaches its maximum loading point, or voltage collapse point. As a result, local and sufficient reactive power assistance is required. To solve the mentioned problems of low bus voltage and high power losses, STATCOM can be used depending on optimal size and location which is achieved in the proposed approach with advantages of easy for understanding and implementation, adopting the newest optimization algorithm which is WOP, It is applicability on real large power system and taking into consideration minimizing the active and reactive power losses in addition to voltage improvement of the whole power system with accurate and acceptable results. Collecting all these features in the proposed approach proves its importance and new contribution.

3. The aim and objectives of the study

The aim of the study is to improve the voltage profile and stability of the power system and minimizing power losses by adding STATCOM device to the system.

To achieve this aim the following objectives are accomplished:

- improving the voltage profile of the system by proposing an approach which identifies the optimal size and location of STATCOM device in the power system by using Whale Optimization Algorithm (WOA) and applying the approach on a large scale power system of Kurdistan Region of Iraq;
- minimizing the active and reactive power losses in the power system depending on the optimal size and location of STATCOM device determined by the proposed approach.

4. Materials and methods

Power System Simulator for Engineering (PSSE) software is used for simulating the large scale power system of Kurdistan Region (KR) and conducting the load flow for identifying the weak buses and selecting the optimal location from these buses to add STATCOM device with optimal size to improve the voltage of all weak buses. Matlab code is used for implementing the WOA. The optimization process is carried out by using an objective function which takes into consideration STATCOM size, voltage deviation, active and reactive power losses which is the main contribution in this work.

4. 1. Power system STATCOM components

STATCOM is a type of shunt FACTS device used to compensate the reactive power in transmission lines [16, 17]. It can modify power flows, absorb and provide reactive power. It increases all types of stability of the system by providing reliable control for the transmission parameters, i.e. voltage magnitude, phase angle and line impedance [18]. The basic components of STATCOM device is shown in Fig. 1.

The amplitude and phase angle of the voltage have a big impact on whether a STATCOM absorbs or produces reactive power [14]. STATCOM uses the Voltage Source Converter (VSC) to inject a current with variable values and frequency to the system. The three phase VSC is connected to capacitance or a battery in the DC side. STATCOM is similar to synchronous machine which produces balanced three phase sinusoidal voltages with the fundamental frequency and adjustable voltage and phase angle. It acts like an inverter which converts DC voltage into AC for the purpose of reactive power compensation. STATCOM is mainly comprised of four components which are explained in the subsections below [19].

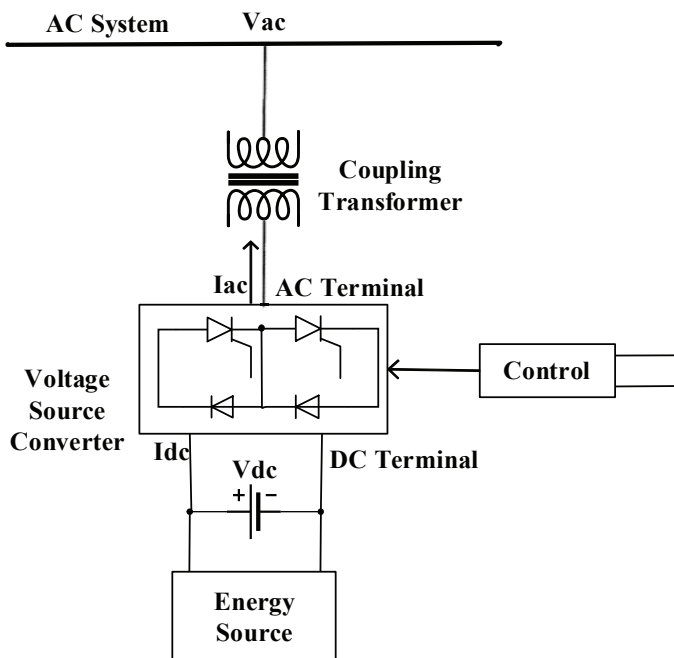

Fig. 1. Basic components of STATCOM

4. 1. 1. Voltage source converter (VSC)

VSC is a device used to generate three phase sinusoidal voltages of a given voltage magnitude, angle and frequency from DC input voltage as shown in Fig. 2. The voltages are in phase and coupled with the AC system through the reactance of the coupling transformer.

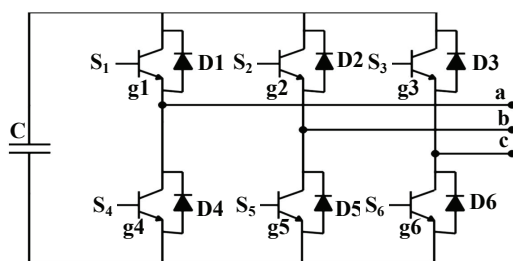

Fig. 2. Three phase VSC

VSC is mainly consists of six power semiconductor devices. By a proper sequence of turning these devices on, a three phase voltage with an adjustable frequency is generated.

4. 1. 2. Coupling transformer

Coupling transformer is necessary to step down system voltage to suit the voltage of VSC. A reactor is generally connected so as to filter out current harmonics that are produced by voltage of the VSC.

4. 1. 3. Controller

It performs feedback control and creates the signals to turn on the semiconductor switches of the VSC to inject reactive component of the current to the network so as to act as an over-excited synchronous generator and support the bus voltage or to absorb reactive component of the current and act like under excited synchronous generator and consequently it decreases the bus voltage. The purpose of the controller is to keep the voltage constant at desired value under disturbances. This controller measures the difference between the actual and desired voltage to create the error signal and send it to the VSC.

4. 1. 4. DC Energy source

The voltage in the DC side of the VSC can be delivered by a capacitor connected in parallel with a battery. The expressions of active power, reactive power, in terms of power system voltage, converter voltage and coupling transformer reactance are shown below [20].

$$P = \frac{V_s V_i}{X_s} \sin \delta, \tag{1}$$

$$Q = \frac{V_s^2}{X_s} - \frac{V_s V_i}{X_s} \cos \delta, \tag{2}$$

where P is the active power; Q is the reactive power; $V_i \angle \theta_i$ is the bus voltage and its phase angle; $V_s \angle \theta_s$ is the STATCOM voltage and its phase angle; X_s is coupling transformer equivalent reactance.

$$\delta = \theta_s - \theta_i. \tag{3}$$

If the AC system phase angle lags the phase angle of the VSC, STATCOM will supply reactive power to the system. Contrariwise, if the phase angle of the system leads that of the VSC, STATCOM will absorb the reactive power [20].

4. 2. Objective function

The purposes of objective function are to obtain the optimal size and location of STATCOM for the best voltage profile of the power system and minimum active and reactive power losses. The objective function is the weighted sum of voltage deviation, the size of STATCOM, active and reactive losses. The minimum value of the objective function is the optimal value as it is clear in equation (4) below.

$$\min O = \left(\sum_{i=1}^{280} (V_i - 1)^2 \right)^{\frac{1}{2}} + \frac{\beta_1}{100} + \frac{\beta_2}{100} + \frac{\beta_3}{1000}. \tag{4}$$

Subject to:

$$|V_i - 1| < 0.1 \text{ for } i = 1, \dots, 280,$$

$$10 \leq \beta_1 \leq 40,$$

where O is the objective function; V_i is the voltage at bus i in per unit (PU); $\left(\sum_{i=1}^{280} (V_i - 1)^2\right)^{\frac{1}{2}}$ is the total voltage deviation; β_1 is the size of STATCOM in MVAR; β_2 is the total active losses of the power system in MW; β_3 is the total reactive power losses of the power system in MVAR.

In this object function, active and reactive powers are considered also. The size of STATCOM is divided by 100, active power is divided by 1000 and active power is divided by 100. These weights are determined by trial and error in such a way that they are comparable.

4. 3. Whale optimization algorithm (WOA)

This algorithm was proposed in 2016 by Seyedali Mirjalili, as a modern optimization approach. It was inspired by the natural behaviour of humpback whales. The most interesting aspect of humpback whales is their unique hunting technique. This foraging habit is referred to as the bubble-net feeding approach. Humpback whales prefer to hunt groups of krill or tiny fish at the surface of the water. This foraging is done by blowing bubbles in a circle or '9'-shaped path [21]. Humpback whales usually dive roughly 12 meters below the surface, and then begin to generate bubbles in a spiral way around their meal and swim up to the top. It is worth noting here that bubble-net feeding is a unique activity found solely in humpback whales. The spiral bubble-net feeding maneuver is mathematically described to undertake optimization. Humpback whales can detect their prey's position and encircle it. Because the optimal design's position in the search area is unknown at the beginning, the WOA assumes that the best current candidate solution is the target prey or is near to it. When the best search agent is determined, the other search agents will attempt to change their locations in relation to the best search agent. The algorithm principles are described below [22]:

4. 3. 1. Prey encircling

During this process, WOA algorithm assumes the present best solution as the location of the target prey, and the whales attempt to encircle the prey while updating their places. This behavior is mathematically represented as follows:

$$\bar{D} = \left| \bar{C} \cdot \bar{X}^*(t) - \bar{X}(t) \right|, \quad (5)$$

$$\bar{X}(t+1) = \bar{X}^*(t) - \bar{A} \cdot \bar{D}, \quad (6)$$

where $\bar{X}(t)$ and $\bar{X}^*(t)$ indicate the position vectors of the individual whale and the target prey (the best optimal solution obtained so far) respectively. The vectors of coefficients \bar{A} and \bar{C} are calculated as below:

$$\bar{A} = 2\bar{a} \cdot \bar{r} - \bar{a}, \quad (7)$$

$$\bar{C} = 2 \cdot \bar{r}, \quad (8)$$

$$\bar{a} = 2 - 2 \frac{t}{t_{\max}}, \quad (9)$$

where \bar{r} is a random variable in the range [0, 1], and \bar{a} is a controlling variable that drops linearly from 2 to 0 throughout the period of the exploration and exploitation stages; t is the present iteration and t_{\max} is the maximum iteration.

Exploration involves local search strategy and tries to develop the promising solution while avoiding large jumps in

search space, whereas exploitation focuses on global search strategy and seeks the search area for most optimum solutions.

4. 3. 2. Bubble-net attacking method (exploitation phase)

WOA simulates humpback whale activity by employing two methods: shrinking encircling and spiral updating. It uses a 50 per cent chance of selecting one of these two procedures to update the locations of whales during the optimization phase. This can be mathematically described as the following:

$$\bar{X}(t+1) = \begin{cases} \bar{X}^*(t) - \bar{A} \cdot \bar{D}, & p < 0.5, \\ \bar{D}' \cdot e^{bl} \cdot \cos(2\pi l) + \bar{X}^*(t), & p > 0.5, \end{cases} \quad (10)$$

where b is a constant used to define the spiral form, p and l are random numbers between [0, 1] and [-1, 1], respectively. To calculate distance from best location equation (11) is used.

$$\bar{D}' = \left| \bar{X}^*(t) - \bar{X}(t) \right|, \quad (11)$$

where D' in this case represents the distance between the current whale position and the best location.

4. 3. 3. Search for prey (exploration phase)

During this procedure, the exploration (global search) capability is strengthened by updating the location of each whales based on position of a randomly selected whale instead of the position of the prey (best optimal solution discovered so far). This drives individual whales to swim away to attain the global optimum instead of being locked in local optimum.

$$\bar{D} = \left| \bar{C} \cdot \bar{X}_{\text{rand}}(t) - \bar{X}(t) \right|, \quad (12)$$

$$\bar{X}(t+1) = \left(\bar{X}_{\text{rand}}(t) - \bar{A} \cdot \bar{D} \right). \quad (13)$$

WOA algorithm begins with random solutions. During each iteration, search agents revise their locations till the best one is obtained.

4. 4. Proposed approach

The proposed approach is applied on a real power system of Kurdistan Region (KR) shown in Fig. 3 which consists of 62 generators with total generation of 3535 MW, 42 transformers, 280 buses and 123 loads.

Fig. 4 shows the flowchart of the proposed approach. Firstly load flow analysis is applied on the system to identify the weak buses which are the buses with voltages lower than the minimum permissible voltage. The bus voltage should lay within the range ($0.9 \leq V_i \leq 1.1$) based on Iraqi Grid Code (IGC). These buses are considered as weak buses and suitable for connecting STATCOM device in order to keep all bus voltages within the permitted range. The proposed approach depends on searching for the optimal location and minimum size of the STATCOM with minimum active and reactive power losses of the whole system. WOA is used for the optimization with the objective function described previously.

The steps for optimization algorithm is applied on KR power system by initializing the whale populations \bar{X} (voltage deviation, STATCOM size, active and reactive power losses) for each weak bus with applying the equations of the optimization process. The parameters of the WOA used in this paper are described in the Table 1 below.

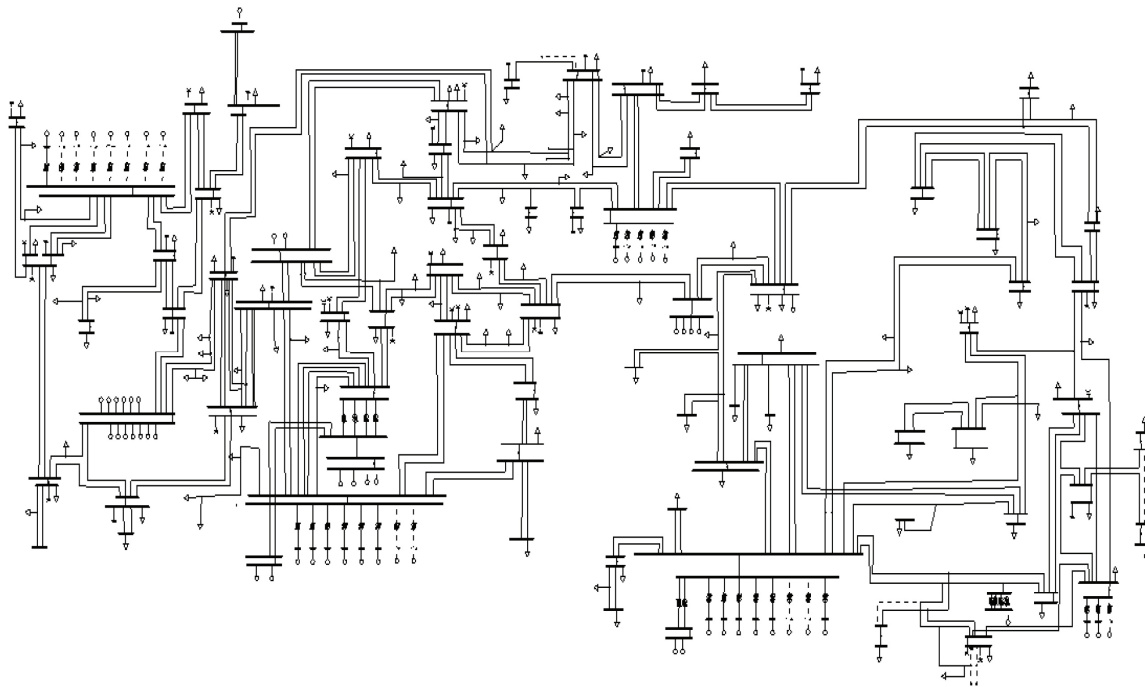

Fig. 3. KR power system

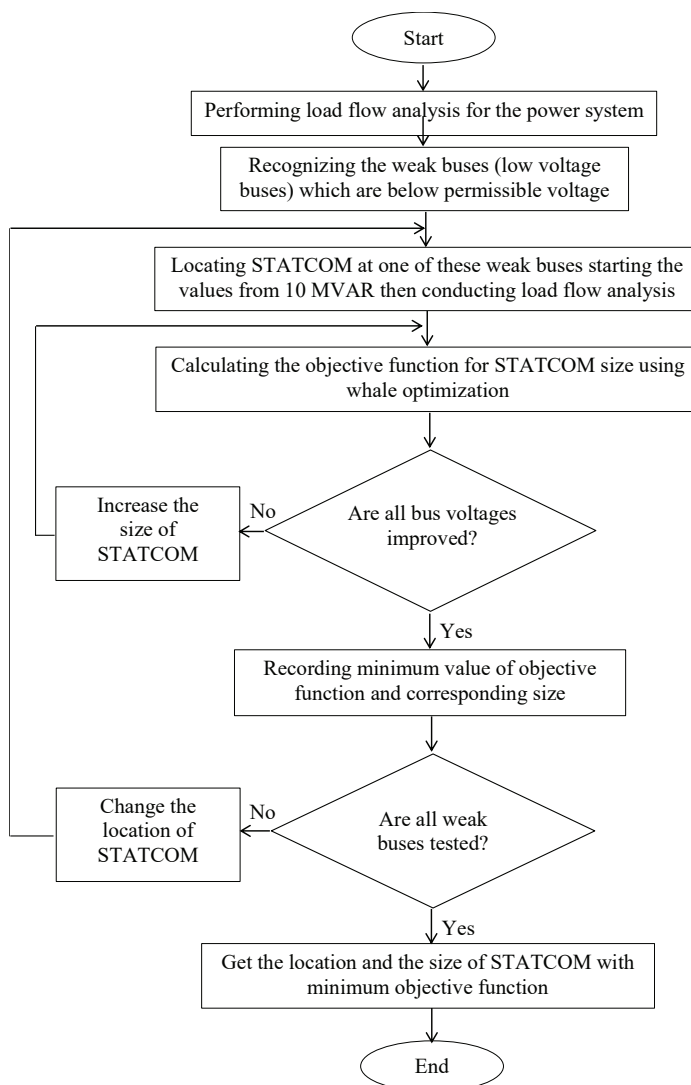

Fig. 4. Flowchart of the proposed approach

Table 1

WOA parameters

Parameters	Values
Search agents	30
Maximum iteration	500
Number of variables	4
Spiral updating	0.5
Probability	0.5
Shrinking encircling random search	0.1

The purpose of the optimization is to improve the voltages of all weak buses to be within the permissible range with minimum size of STATCOM device at optimal bus location and minimum losses of active and reactive power.

5. Results of optimal size and location with minimizing system losses

5.1. Result of optimal size and location

Fig. 5 shows the voltage profile of the system without adding STATCOM device. It is clear that some buses are under minimum permissible range which is 0.9 PU. It is desired to adjust bus voltage within the allowed range to prevent the voltage collapse.

Table 2 shows the optimal results of WOA solution which include STATCOM device, Size of it, voltage deviation and system active and reactive losses. Fig. 6 shows the voltages for the weak buses before and after STATCOM device connection with optimal size and location. It is obvious that the voltages of all weak buses are improved.

In addition to voltage improvement, all weak bus voltages become greater than the lower permissible value which is 0.9 PU as a result of proper selection of size and location.

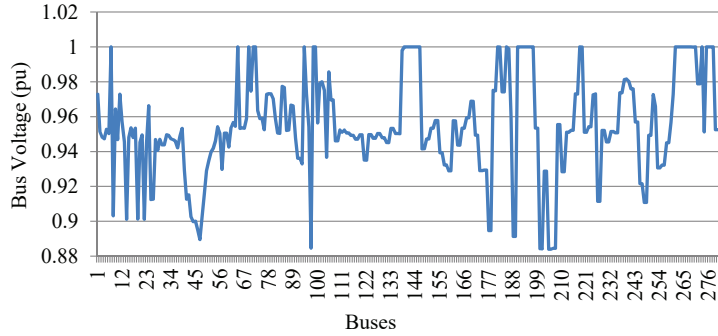

Fig. 5. Voltage profile of KR power system without STATCOM

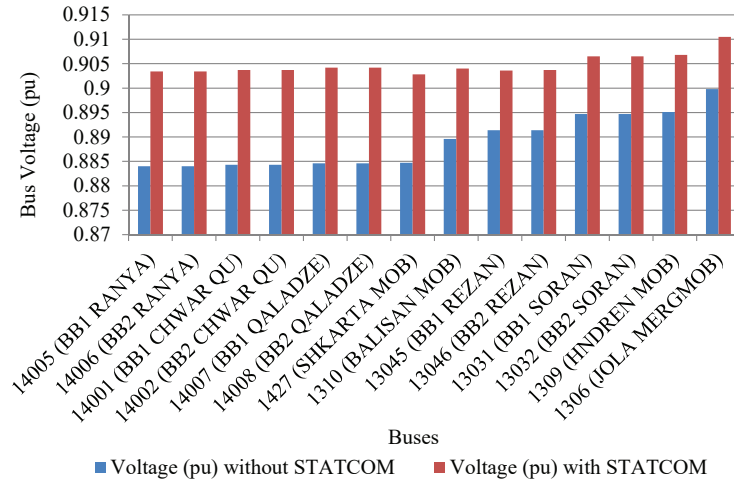

Fig. 6. Low voltage buses before and after STATCOM Connection

Results of optimal values

Terms	Optimal Values
Location	14001 (BB1- CHWAR QU)
Size (MVAR)	25
Voltage Deviation	0
Active Power losses (KW)	78.26
Reactive Power losses (KVAR)	669.18
Objective Function	1.701

Table 2

5. 2. Results of minimizing system losses

As mentioned previously adding STATCOM to the power system participates in reducing active and reactive losses of the whole system. Fig. 7, 8 show the total active and reactive power losses when STATCOM device with optimal size is connected with each weak bus individually.

Fig. 9 shows the voltage profile of the power system before and after STATCOM connection with optimal size and location.

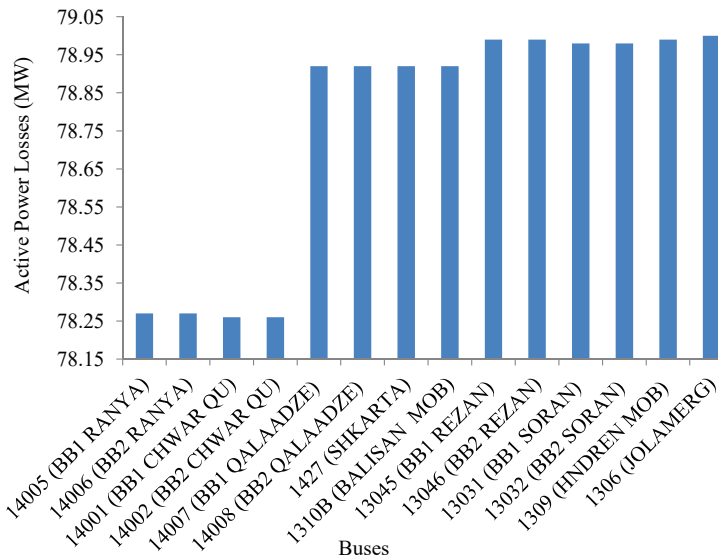

Fig. 7. Active power losses with STATCOM of optimal size at different weak buses

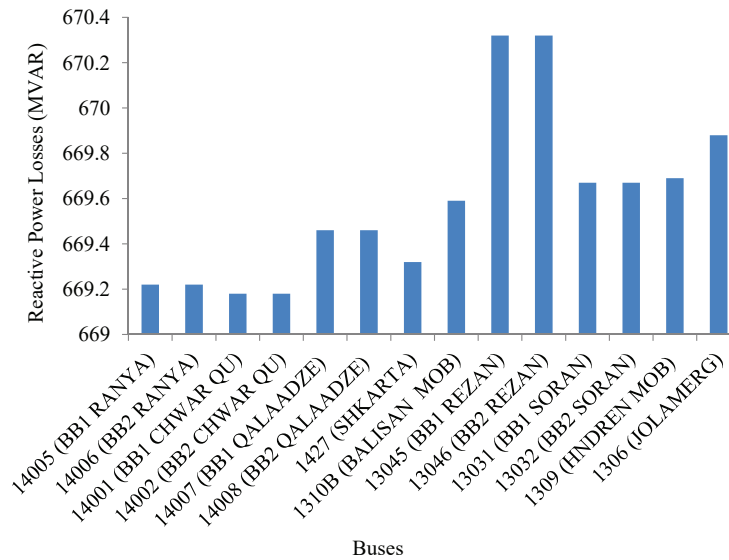

Fig. 8. Reactive power losses with STATCOM of optimal size at different weak buses

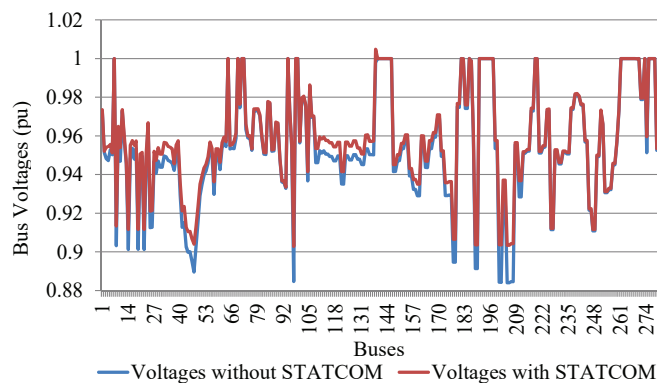

Fig. 9. Voltage profile of KR power system before and after STATCOM connection

From these results the effect of STATCOM device connecting in keeping the voltage of all buses within the allowed limit is very clear.

6. Discussion of the research results of optimal size and location with minimizing system losses

The large scale power system of KR has already some weak buses and their voltages are lower than the allowed value specified by IGC as its clear in Fig. 5. Which is the result of load flow for the system without STATCOM device, it is clear that some buses have voltages lower than 0.9 PU which is the minimum permitted value. As a result there is a need to raise these voltages by STATCOM device with proper size and location.

Optimal results of size and location in Table 2 show that by connecting STATCOM device, the voltage deviation becomes zero which means that all bus voltages are within the acceptable range. In addition to the improvement in the low bus voltage, the voltages of most of the buses are also increased as it is obvious in Fig. 9. The optimal size of the STATCOM is 25 MVAR located at the bus 14001(BB1 CHWAR QU), the value of the objective function is 1.70178 which is the minimum value of the objective function.

It is also noticed that by connecting the STATCOM of optimal size and location, the active and reactive power losses

are also reduced, it is obvious that the active power losses are reduced from 79.4004 MW which is the total system active losses without STATCOM to 78.26 MW which is the minimum value of the active losses as compared to values of active losses in case of connecting the STATCOM to other weak buses as shown in Fig. 7 which means reduction by 1.43 %. The reactive power is also reduced by connecting the STATCOM with optimal size and location. These losses are reduced from 676.6 MVAR which is the value of system reactive losses without STATCOM device to 673.18 MVAR which is the minimum value of the reactive losses as compared to the values of reactive losses in case of connecting the STATCOM to other weak buses as shown in Fig. 8. The reduction in reactive losses is by 0.5 %. The most important advantage of the proposed approach is that it considers power losses reduction in addition to improving the bus voltages. For future work, a comparison study of using other FACTS devices which is not adopted in this study may develop and strengthen it.

7. Conclusions

1. An approach is proposed for bus voltage improvement by adding STATCOM device to the power system. Size and location of the STATCOM used in the approach is found by using WOA which is a modern optimization technique. The

proposed optimization objective function takes into consideration bus voltage and power system loss minimization. The approach is applied on real KR power system. It is concluded that the optimal size of the STATCOM is 25 MVAR connected to the bus 14001 (BB1 Chwar Qu) to achieve zero bus voltage deviation.

2. The active and reactive power losses are also minimized by connecting the STATCOM device with optimal size and location obtained from the optimization process. The active losses are reduced from 79.4 MW to 78.26 MW, and the reactive losses are reduced from 676.6 MVAR to 669.18 MVAR. The main advantage of the proposed approach is that it minimizes the total active and reactive losses

of the whole power system in addition to bus voltage improvement using a new and modern optimization algorithm which is WOA and this is the main difference from other approaches used for locating and sizing the STATCOM device in the power system for bus voltage improvement.

Acknowledgments

The authors would like to express their gratitude to the Ministry of Electricity/General Directorate of Transmission in Kurdistan Region for providing the required data and information which helped in improving our task.

References

1. Shah, S. O., Arshad, A., Alam, S. (2021). Reactive Power Compensation Utilizing FACTS Devices. 2021 International Conference on Emerging Power Technologies (ICEPT). doi: <https://doi.org/10.1109/icept51706.2021.9435455>
2. Joshi, B. S., Mahela, O. P., Ola, S. R. (2016). Reactive power flow control using Static VAR Compensator to improve voltage stability in transmission system. 2016 International Conference on Recent Advances and Innovations in Engineering (ICRAIE). doi: <https://doi.org/10.1109/icraie.2016.7939504>
3. Moghavvemi, M., Faruque, M. O. (2000). Effects of FACTS devices on static voltage stability. 2000 TENCON Proceedings. Intelligent Systems and Technologies for the New Millennium (Cat. No.00CH37119). doi: <https://doi.org/10.1109/tencon.2000.888762>
4. Telang, A. S., Bedekar, P. P. (2016). Application of voltage stability indices for proper placement of STATCOM under load increase scenario. International Journal of Energy and Power Engineering, 10 (7), 998–1003. Available at: <https://publications.waset.org/10006054/application-of-voltage-stability-indices-for-proper-placement-of-statcom-under-load-increase-scenario>
5. Lakkireddy, J., Rastgoufard, R., Leevongwat, I., Rastgoufard, P. (2015). Steady state voltage stability enhancement using shunt and series FACTS devices. 2015 Clemson University Power Systems Conference (PSC). doi: <https://doi.org/10.1109/psc.2015.7101706>
6. Minguez, R., Milano, F., Zarate-Minano, R., Conejo, A. J. (2007). Optimal Network Placement of SVC Devices. IEEE Transactions on Power Systems, 22 (4), 1851–1860. doi: <https://doi.org/10.1109/tpwrs.2007.907543>
7. El Metwally, M. M., El Emary, A. A., El Bendary, F. M., Mosaad, M. I. (2008). Optimal allocation of FACTS devices in power system using genetic algorithms. 2008 12th International Middle-East Power System Conference. doi: <https://doi.org/10.1109/mecon.2008.4562386>
8. Farsangi, M. M., Nezamabadi-pour, H., Song, Y.-H., Lee, K. Y. (2007). Placement of SVCs and Selection of Stabilizing Signals in Power Systems. IEEE Transactions on Power Systems, 22 (3), 1061–1071. doi: <https://doi.org/10.1109/tpwrs.2007.901285>
9. Kumarasamy, K., Raghavan, R. (2012). Particle Swarm Optimization algorithm for voltage stability improvement using multiple STATCOM. 2012 International Conference on Emerging Trends in Electrical Engineering and Energy Management (ICETEEEM). doi: <https://doi.org/10.1109/iceteem.2012.6494493>
10. Rao, P., Crow, M. L., Yang, Z. (2000). STATCOM control for power system voltage control applications. IEEE Transactions on Power Delivery, 15 (4), 1311–1317. doi: <https://doi.org/10.1109/61.891520>
11. Sharma, N. K., Ghosh, A., Varma, R. K. (2003). A novel placement strategy for facts controllers. IEEE Transactions on Power Delivery, 18 (3), 982–987. doi: <https://doi.org/10.1109/tpwrd.2003.813874>
12. Xiao, Y., Song, Y. H., Sun, Y. Z. (2002). Power flow control approach to power systems with embedded FACTS devices. IEEE Transactions on Power Systems, 17 (4), 943–950. doi: <https://doi.org/10.1109/tpwrs.2002.804919>
13. Yang, C.-F., Lai, G. G., Lee, C.-H., Su, C.-T., Chang, G. W. (2012). Optimal setting of reactive compensation devices with an improved voltage stability index for voltage stability enhancement. International Journal of Electrical Power & Energy Systems, 37 (1), 50–57. doi: <https://doi.org/10.1016/j.ijepes.2011.12.003>
14. Mahmood, F. B. K., Ahmad, S., Mukit, G., Shuvo, M. T. I., Razwan, S., Maruf, M. N. I., Albatsh, F. M. (2017). Weakest location exploration in IEEE-14 bus system for voltage stability improvement using STATCOM, synchronous condenser and static capacitor. 2017 International Conference on Electrical, Computer and Communication Engineering (ECCE). doi: <https://doi.org/10.1109/ecce.2017.7912980>
15. Al Mamari, A. S., Toha, S. F., Ahmad, S., Al Mamari, A. S. (2021). A modal analysis based on reactive power compensation on 6-bus Oman electrical grid. International Journal of Power Electronics and Drive Systems (IJPEDS), 12 (2), 757. doi: <https://doi.org/10.11591/ijpeds.v12.i2.pp757-764>
16. Mukhopadhyay, B., Mandal, R. K., Choudhary, G. K. (2017). Voltage Compensation In Wind Power System Using STATCOM Controlled By Soft Computing Techniques. International Journal of Electrical and Computer Engineering (IJECE), 7 (2), 667. doi: <https://doi.org/10.11591/ijece.v7i2.pp667-680>

17. Alatshan, M. S., Alhamrouni, I., Sutikno, T., Jusoh, A. (2020). Application of static synchronous compensator and energy storage system for power system stability enhancement. *Bulletin of Electrical Engineering and Informatics*, 9 (6), 2222–2234. doi: <https://doi.org/10.11591/eei.v9i6.2319>
18. Khan, S., Bhowmick, S. (2014). STATCOM modeling for power flow analysis. 2014 6th IEEE Power India International Conference (PIICON). doi: <https://doi.org/10.1109/poweri.2014.7117603>
19. Kadandani, N. B., Maiwada, Y. A. (2015). Simulation of Static Synchronous Compensator (STATCOM) for Voltage Profile Improvement. *Innovative Systems Design and Engineering*, 6 (7). Available at: <https://citeseerx.ist.psu.edu/viewdoc/download?doi=10.1.1.1013.4109&rep=rep1&type=pdf>
20. Lin, W.-M., Lu, K.-H., Huang, C.-H., Ou, T.-C., Li, Y.-H. (2009). Optimal location and capacity of STATCOM for voltage stability enhancement using ACO plus GA. 2009 IEEE/ASME International Conference on Advanced Intelligent Mechatronics. doi: <https://doi.org/10.1109/aim.2009.5229769>
21. Mirjalili, S., Lewis, A. (2016). The Whale Optimization Algorithm. *Advances in Engineering Software*, 95, 51–67. doi: <https://doi.org/10.1016/j.advengsoft.2016.01.008>
22. Vaiyapuri, T., Alaskar, H. (2020). Whale Optimization for Wavelet-Based Unsupervised Medical Image Segmentation: Application to CT and MR Images. *International Journal of Computational Intelligence Systems*, 13 (1), 941. doi: <https://doi.org/10.2991/ijcis.d.200625.001>