

**Wireless Fidelity (Wi-Fi) broadband network technology has created great influence in the evolution of broadband wireless networks that are anticipated to progress regarding broadband speed and coverage. Several Wi-Fi hotspots are available everywhere, making it a medium of internet access that is easier to use compared to a local area network (LAN). However, the internet being the best effort network doesn't provide the required Quality of Service (QoS) and there is no differentiation of service traffic. The chief aim of the current paper is to study the operation of the three organizing mechanisms: First-In, First-Out (FIFO) method – the standard method of network implementation to process the packets one by one as it arrives, Priority Queuing (PQ) and Weighted Fair Queuing (WFQ) whereas PQ and WFQ classify the types of traffic based on service priority. In addition, WFQ assigns fair weight to each service on multiple traffic classes like video conferencing, Voice over Internet Protocol (VoIP), and File Transfer Protocol (FTP), using Telkom ST3's Wi-Fi network. This study applies four different scenarios: the first scenario applies the methods without any queuing discipline; the second scenario implements the methods with FIFO; the third scenario carries out the methods with PQ and the last scenario applies the methods with WFQ. The studies have shown that “end-to-end packet delay and packet delay variation for VoIP in the WFQ scenario” is good when compared to other queuing mechanisms with values of 171.717 ms and 0.977 ms, respectively. In the case of videotape conferencing also, the performance is better in the case of WFQ with values of 32.495 ms and 7.207 ms, correspondingly, since the WFQ has a “bandwidth allocation” tailored to the requirements**

**Keywords: Wi-Fi, QoS, FIFO, PQ, WFQ, VoIP, FTP, Telkom ST3's, end-to-end packet delay**

# CHARACTERISTIC ANALYSIS OF QUEUE THEORY IN WI-FI APPLICATIONS USING OPNET 14.5 MODELER

**Ali Hamzah Najim**

*Corresponding author*

Master in Electronic & Communication Engineering

Department of Computer Technical Engineering

Imam Al-Kadhum College (IKC)

Al-Diwaniyah, Iraq, 58001

E-mail: aliamza@alkadhum-col.edu.iq

**Hassnen Shakir Mansour**

Master in Information Technology

and Systems Techniques Engineering\*

**Ali Hashim Abbas**

Doctorate Degree in Vehicular Ad Hoc Networks (VANETs)\*

\*Department of Computer Technical Engineering

College of Information Technology

Imam Ja'afar Al-Sadiq University

Al-Muthanna, Iraq, 66002

Received date 17.01.2022

Accepted date 18.04.2022

Published date 29.04.2022

**How to Cite:** Najim, A. H., Mansour, H. S., Abbas, A. H. (2022). Characteristic analysis of queue theory in Wi-Fi applications using OPNET 14.5 modeler. *Eastern-European Journal of Enterprise Technologies*, 2 (9 (116)), 35–43.

doi: <https://doi.org/10.15587/1729-4061.2022.255520>

## 1. Introduction

Wi-Fi symbolizes “Wireless Fidelity” utilized to define the products of Wireless LAN (WLAN) that are built on the IEEE 802.11 criteria. It utilizes both single carrier direct-sequence spread spectrum radio technology and multi-carrier OFDM (Orthogonal Frequency Division Multiplexing) radio technology that empowered its advance and its one-time competitor HomeRF and Bluetooth. The Wi-Fi first products were offered in the marketplace carrying the term “WaveLAN with speeds of 1 Mbit/s to 2 Mbit/s” and criteria were made as IEEE 802.11b, and 802.11. Wi-Fi Alliance, which possesses Wi-Fi, is a group of distinct and self-governing corporations concurring to a group of mutual interoperable productions built on the family of IEEE 802.11 criteria [1]. The products of Wi-Fi Association members that permit the interoperability experiments could be marked with the logo of Wi-Fi. Wireless network technology such as Wi-Fi has been widely used in the community because of the advantages of low cost and easy internet access. Wi-Fi hotspots are widely available nowadays in various places like housing, offices, cafes, and educational institutes making internet media access easier compared to local area networks. Internet is the best service wherein if the traffic exceeds the predetermined bandwidth, then it is simply dropped. Delay-sensitive applications like video conferencing

are the most prioritized services to achieve the required QoS guarantees in the system. It is very important to present the required QoS guarantees for services that are easily affected by delay and jitter. The purpose of this work is to show how the OPNET simulator software can be used to evaluate in detail the preparedness of current IP networks in assistance of “File Transfer Protocol (FTP)”, “video conferencing, and Voice over Internet Protocol (VoIP)” services and evaluate the performance of different scheduling mechanisms to achieve required QoS suitable for use in Telkom ST3 campus network topology. Since its start in 1997, the technologies of Wi-Fi passed some stages [2]. It is reinforced in various degrees under Apple Macintosh, Microsoft Windows, open-source UNIX, and Linux operating systems [3].

The FIFO method is the standard method of network implementation, where the packets are processed one by one as it arrives. It examines and assesses some devices to enhance the WLANs throughput performance. From the result, the performance of WLAN was enhanced by changing parameters such as slot time, short inter-frame spacing, minimum contention window, fragmentation threshold, and request to send (RTS) thresholds. However, it customizes parameters against utilizing the values stated in the standards will minimize crashes and postponements, and maximize throughput and channel operation under numerous load circumstances [4].

Statistical comparison of inter-arrival time distribution to the VoIP traffic performance over WiMAX networks by examining the Quality of Service (QoS), such as postponement, jitter, throughput regarding Voice Activity Detection (VAD) or Silence Detection (SD) in the G.729 voice codec. The result of the simulation indicates to Pareto distribution in inter-arrival time has an important influence on the performance of VoIP in WiMAX networks [5].

The study [1] addressed “Wi-Fi fixed broadband technology” and investigated its connection with other webs (immobile and moveable), its pros and cons, and the coming predictions in broadband wireless network technology, particularly its amalgamation with WiMAX network. Moreover, they examine the uses, pros, and cons of the Wi-Fi broadband wireless network technology compared with other broadband wireless networks and amalgamation with the WiMAX network.

Advance networks to deliver Internet connectivity to mobile Wi-Fi manipulators are highly expected. This work explores the use of the Header Compression algorithm in wireless networking, the uses, pros, and cons of the Wi-Fi broadband wireless network technology compared with other broadband wireless networks, and amalgamation with the advanced web. Moreover, our results are evaluated with other existing system performances [6], where the study focuses on the performance evaluation of distributed “true video-on-demand (T-VoD)”. In their study, a linked video server web construction for video on demand (VoD) systems was considered. This was achieved under the propositions of unchanging loading and harmonic network. For the two server chosen tactics (Random and Least Loaded) and two reservation outlines (severe reservation and remaining reservation), different models were suggested. A queuing model for the allocated video on demand (VoD) system was developed. It concentrates on deriving the obstructive likelihood and the bandwidth price (on the completely associated central web) provided by the efficiency of video servers. Other measures of performance, like the continuous facility reply postponement, the number of needed video buffers, and the needed network efficiency were not treated in their research [7]. Different issues about the security aspect of broadband technology were considered in [8], where a comparison between 802.11 (Wi-Fi) and 802.16 (WiMAX) wireless networks was carried out based on frequency, band, coverage, security, radio technology, modulation, data rates, and others. On the aspect of security, it has concerns broadband network, Denial of Service (DoS) attack, Distributed Flooding attack, Rogue and selfish backbone devices attack and Node deprivation attack were all considered.

A comparison regarding bandwidth use, number of concurrent clients, damage percentage, and end-user recognized quality. The findings of the simulation show the QOAS system can provide an outstandingly large number of concurrent customers and also have large bandwidth use for a similar average end-user quality. The average end-user quality is frequently higher for QOAS than for the other resolutions examined for the same number of clients [9]. PQ has four configured queues, such as high, medium, normal, and low priority queues. Each queuing priority has a default packet capacity of 20, 40, 60, and 80. If the incoming packet is a high-priority packet, the PQ method will prioritize the existing resource to send the packets, and the remaining queues will be empty [10]. PQ becomes the basis of the scheduling scheme based on the queue class. The mechanism

of this scheme is that each packet is marked by a priority and then the package is classified by the system and entered into different priority classes. In each priority class, the packets are then scheduled based on priority. The advantage of this mechanism on the internetwork is to safeguard routing update packets by providing higher priority and exclusive queue on the router [11]. The Voice over IP (VoIP) administration requests high needs over different administrations and applications. The presentation of Voice over IP (VoIP) in 802.11 remote organizations explains the assessment of voice parcel start to finish deferral and throughput. Make on OPNET that is reenacted to evaluate the nature of administration (QoS) of VoIP in 802.11g heritage and 802.11e remote organization; shows the upgrade of 802.11, reflects an improvement like the VoIP administration. The recreation results have demonstrated that the nature of VoIP administration is impacted by the nature of the transporter, which is IEEE 802.11 organization. In this way, the voice administration over remote organizations can be improved altogether by fostering the nature of administration strategy that focuses on the parcel transmission in light of the controlled admittance instruments. In the long run, the quantity of VoIP calls could be expanded utilizing the upgraded 802.11e standard instead of 802.11. Tragically, some obliges are related to this ongoing help, for example, postponement and throughput, which should be addressed before conveying to the client.

Therefore, studying the operation of the three organizing mechanisms is essential that are represented by “First-In, First-Out (FIFO), Priority Queuing (PQ), and Weighted Fair Queuing (WFQ)” on multiple traffic classes like video conferencing, Voice over Internet Protocol (VoIP) and File Transfer Protocol (FTP), using Telkom ST3’s Wi-Fi network.

---

## 2. Literature review and problem statement

---

The study [12] discussed the WFQ technique, which is based on a queued packet data stream with two actions simultaneously, namely scheduling over queuing processes and bandwidth allocation. Although WFQ provides fair resource allocation to all network traffic to smoothen “jitter, latency, and packet loss”, the packets have different groups and are placed into a queue and limited to one method. These issues were explored also in [13] and techniques were proposed such as video conferencing and VoIP. The paper [14] considered three services including FTP, video conferencing, and VoIP. FTP is a protocol that serves to transmit and receive files in a network that has support for TCP/IP. Videoconferencing is a multimedia application that allows data communication, voice, and images that are duplex, real-time, and can be applied to networks that have large data transfer rates because of their large bandwidth capacity. Video conferencing can be a key solution for people to communicate remotely by using computers and internet media, while VoIP is a “technology that makes the internet media be able to do voice communication remotely. Analog voice signals are converted into digital data and transmitted over the network in the form of real-time data packets” as discussed in [15]. The portability in IP networks is an interest that works with IP applications and administrations, particularly in remote organizations. However, such a technique is still a complex and time-consuming method. The paper [16] used OPNET

to simulate several realistic application traffic scenarios to facilitate the networking issues by analyzing the QoS parameters including delay, jitter, Mean Opinion Score, and packet loss ratio to improve multimedia applications over 802.11 networks within a metropolitan area networking environment while sharing the network resources with HTTP and video applications.

An early study such as [17], a new plan to ensure QoS for asset serious traffic, for example, a video even with asset shortage in the organization by focusing on certain (yet not all) video parcels and guaranteeing asset distribution to these bundles over others. However, this plan is executed in the connection point between the Logical Link Control (LLC) layer and the Media Access Control (MAC) layer of an 802.11 convention stack. The problem here is that the plan prompts limited improvement in video quality at the beneficiary end. This issue was improved by the study [18], which used the OPNET 14.5 Simulator platform to evaluate the performance of networks with VOIP technology, and the result showed the best VoIP codec. Various VoIP codecs were discussed in [11] by assessing the exhibition of various VoIP codecs over the best exertion WiMAX organization. The execution measurements like jitter, one-way postponement, parcel misfortune, and client discernment metric with Mean Opinion Score have been utilized to assess the presentation of VoIP codecs. Although the reproduction is performed in the QualNet test system with fluctuating up-sides of Packet size, the outcomes demonstrate that the jitter cushion size and packetization time influence the nature of voice over the best exertion organization.

All the above issues reveal the importance of assessing the performance of three commonly used queuing devices, including “First-In-First-Out (FIFO), Priority Queuing (PQ), and Weighted Fair Queuing (WFQ)” to compare and decide the best of the three queuing mechanisms. Moreover, an extension of previous research is required by analyzing three services namely HTTP, FTP, and video. Parameters like throughput and delay are needed to test overall applications as the jitter parameter is only tested in the video application.

### 3. The aim and objectives of the study

The aim of the study is to observe traffic management on the Wi-Fi STT Telematics Telkom network to get accurate results.

To achieve this aim, the following objectives are accomplished:

- to analyze the FIFO parameter to measure the influence of the arrival time for data packets;
- to explore PQ, and WFQ parameters to classify the types of traffic based on service priority. In addition, WFQ assigns fair weight to each service;
- to analyze three services namely HTTP, FTP, and video based on throughput and delay for all the appli-

cations, while the jitter parameter is only tested in the video application.

## 4. Materials and methods

### 4.1. Research object

In this work, we discuss how the three organizational methods function to process packets in the First-in-First-Out (FIFO), Priority Queuing (PQ), and Weighted Fair Queuing (WFQ) networking protocols throughout different scenarios.

Before creating a simulation model, it is required to know the characteristics of the network to be modeled, the campus network ST3 Telkom. Fig. 1 is the Telkom ST3 campus network topology created using OPNET Modeler 14.5 simulator.

The components used in the simulation using this OPNET simulator are:

- 1) Application Configuration one block;
- 2) Profile Configuration one block;
- 3) QoS Configuration one block;
- 4) Ethernet4\_slip8\_gtwy three numbers, configured as routers;
- 5) Ethernet16\_switch eight blocks, configured as switches;
- 6) Ip32\_cloud one block, as IP Cloud;
- 7) XDSL\_Modem one block, configured as a modem;
- 8) WLAN\_ethernet\_router 18 numbers, as access points;
- 9) Ethernet\_wkstnsix numbers, as users with LAN;
- 10) PPP\_server three blocks, as the service server;
- 11) WLAN\_wkstn90 numbers, as users with Wi-Fi;
- 12) 100BaseT links for each local node;
- 13) Link ppp\_ds1 for each server node.

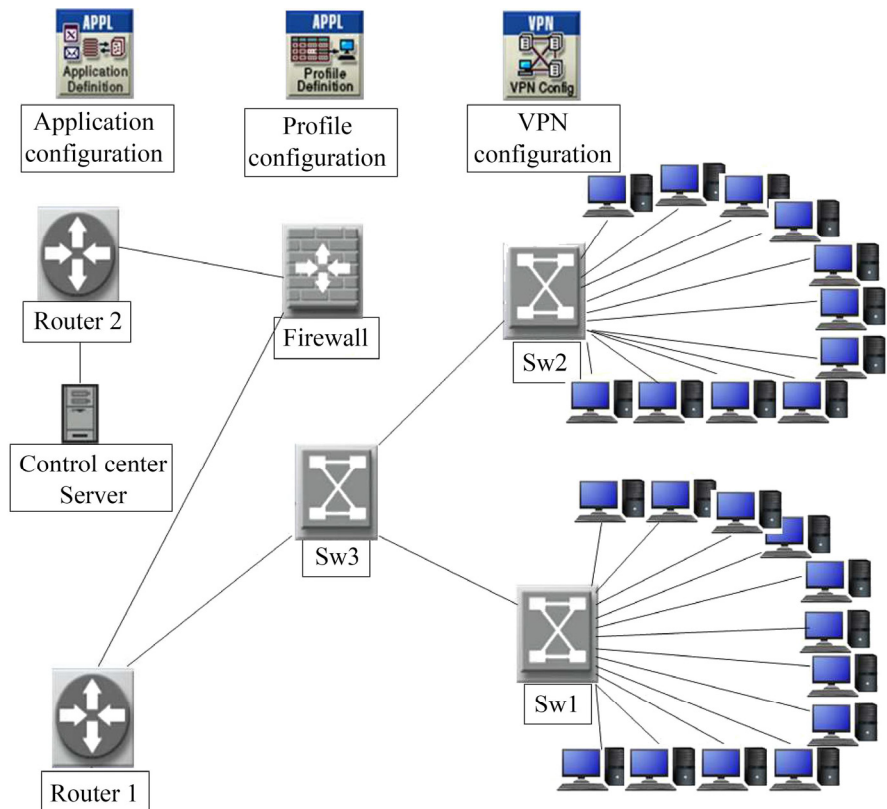

Fig. 1. ST3 campus network topology created using OPNET Modeler 14.5 simulator

In addition, WFQ assigns fair weight to each service on multiple traffic classes like video conferencing, Voice over Internet Protocol (VoIP), and File Transfer Protocol (FTP), using Telkom ST3's Wi-Fi network. In this study, we apply four different scenarios: the first scenario applies the methods without any queuing discipline; the second scenario implements the methods with FIFO; the third scenario carries out the methods with PQ and the last scenario uses the methods with WFQ. Fig. 2 shows three different sorting behaviors: FIFO, PQ, and WFQ.

The analysis and evolution of the above methods are based on continuous packet delay, throughput, data dropped, and packet delay variation. Four different scenarios are considered to evaluate these networking parameters with respect to previous works. Table 1 shows the parameters and scenarios used in the evaluation of this research.

Table 1

Parameters and scenarios used in the evaluation

Scenarios	Queue theory	Service	QoS parameters
Scenario 1	Without Queue	VoIP, Video conference, and FTP	Continuous packet delay, throughput, data dropped, and packet delay variation
Scenario 2	FIFO		
Scenario 3	PQ		
Scenario 4	WFQ		

From Table 1, the first scenario applies all the services without queue then analyzes the delay, throughput, and packet drop. The second scenario applies all the services using FIFO to analyze the delay, throughput, and packet drop. The third scenario applies all the services using PQ to analyze the delay, throughput, and packet drop. The last scenario used Weighted Fair Queuing to analyze the delay, throughput, and packet drop.

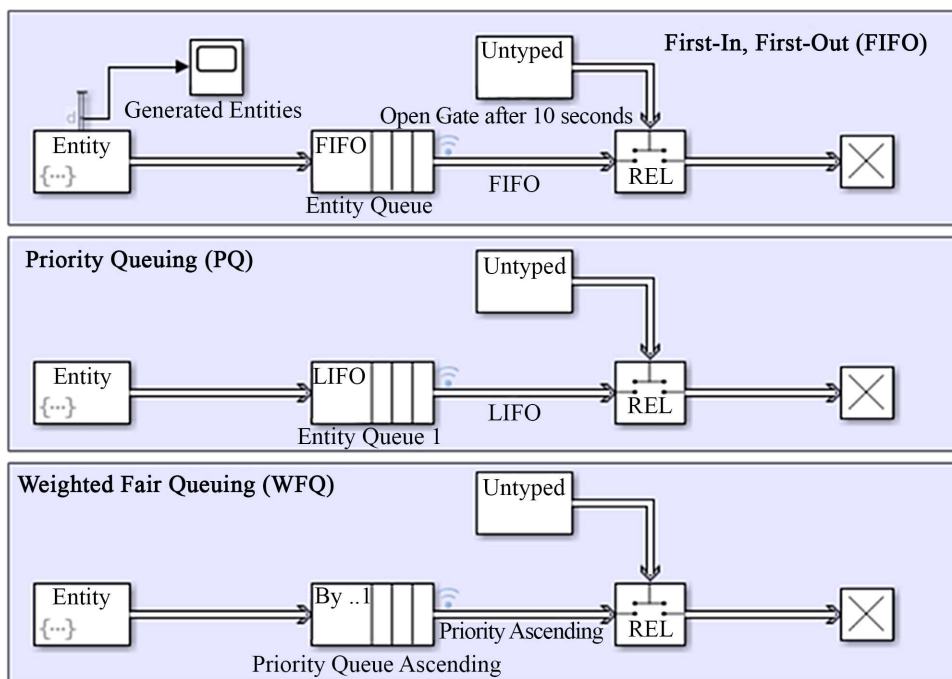

Fig. 2. Three different sorting behaviors: FIFO, PQ, and WFQ

4. 2. VoIP services

The VoIP services G.711 codec is used, which is the international standard for the audio encoding of the phone on a 64 Kbps channel. The standard uses Pulse Code Modulation

(PCM) operating at a sampling rate of 8 kHz, with eight bits per sample. Another important feature is "voice frame per packet". "Voice frame" is composed of 32 sound samples. One sample consists of 8 bits, so the size of each voice frame is 32 octets. Thus, according to the principles used, VoIP packets have a payload of 160 octets, so the value of "voice frame per packet" is set to five frames.

The bandwidth required for voice calls in any route is 50 packets per second or 90.4 Kbps with the packet above. The G.711 codec samples 20 ms of voice per packet. As a result, fifty packets will be transferred in a second, where each packet consists of 160 sound samples in connection to produce 8,000 sound samples in a second sending each packet in an Ethernet frame, with each packet consisting of 160 octets, plus the header of the protocol layer [17, 18]. Table 2 shows the parameters used in VoIP service.

Table 2

VoIP service parameters

Attribute	Value
Silence Length (Sec)	default
Talk Spurt	default
Symbolic Destination Name	Voice Destination
Encoder Scheme	G.711
Voice Frames per Packet	5
Type of Service	EF
RSVP Parameters	None
Traffic Mix (%)	All Discrete

After setting parameters in the application configuration and profile configuration on all services, the time of simulation is adjusted to ten minutes.

4. 3. Video conferencing services

Video conferencing is extensively utilized for medical aims and numerous researches concentrated on the ways that technologies can enhance video conferencing applications. The frame interarrival time represents the number of image frames sent on 10 frames/second, a frame size data of "128x120 pixels". Each frame was equivalent to a constant payload of 17,280 octets. The Type of Service (ToS) value is configured as AF (Assured Forwarding), which denotes the DS code point, indicating that the application service defined by video conferencing has higher priority than VoIP. Table 3 shows the Video Conferencing parameters used in the simulation of this study.

After setting parameters in the application configuration and profile configuration on all services, the time of simulation is adjusted to five minutes.

Table 3

Video Conferencing service parameters

Attribute	Value
Frame Interarrival Time Information	10 frame/Sec
Frame Size Information (bytes)	128*120 pixels
Symbolic Destination Name	Video Destination
Type of Service	AFA3
RSVP Parameters	None
Traffic Mix (%)	All Discrete

4.4. File transfer protocol services

File transfer protocol (FTP) is a term that is defined as a procedure that requires files transfer between devices over a web. The procedure functions when one group permits another to direct or obtain files over the net. It was initially utilized as a means for manipulators to interact and communicate details among two concrete devices. Now it is generally utilized to save archives in the cloud (a safe site that is settled distantly). In this research, the FTP used maximum command is 50 %, where the inter-request time is 3600 seconds with a file size of 1,000 bytes, the kind of facility best effort (0). The FTP services used in this simulation are shown in Table 4.

In file transfer protocol, the inter-request time uses exponential (3,600) in seconds where the file size is 1,000 bytes. In the event of a video conference facility, an analysis is conducted to find out the best queuing mechanism.

Table 4

FTP service parameters

Attribute	Value
Command Mix (Get/Total)	50 %
Inter-Request Time (Sec)	Exponential (3,600)
File Size (bytes)	Constant (1,000)
Symbolic Destination Name	FTP Server
Type of Service	Best Effort(0)
RSVP Parameters	None

The evaluation of performance is according to end-to-end (E2E) delay and latency. In both cases, it is interpreted that the greater the delay the better the quality. FIFO queuing discipline does not have queuing class division mechanisms

so the delay-sensitive VoIP and video conference QoS settings are difficult.

5. Results of analyzing queue theory using OPNET 14.5 modeler

5.1. Video conferences based on Packet E2E and latency for FIFO, PQ, and WFQ

Fig. 3, 4 show a comparison of packet E2E delay and packet delay (latency) for video conferences among FIFO, PQ, and WFQ network techniques.

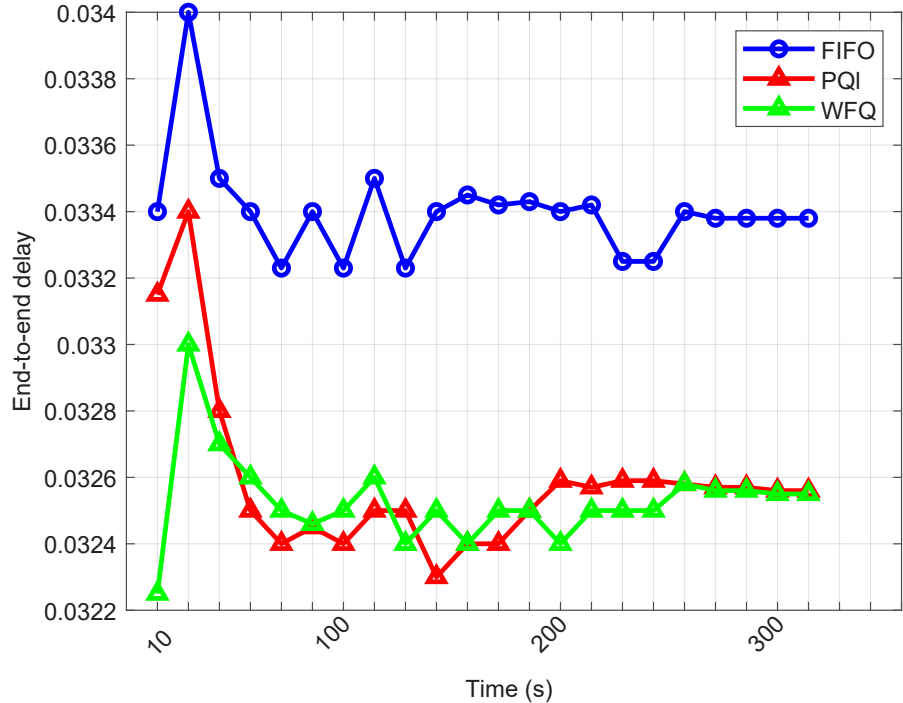

Fig. 3. Packet E2E Delay Video Conference

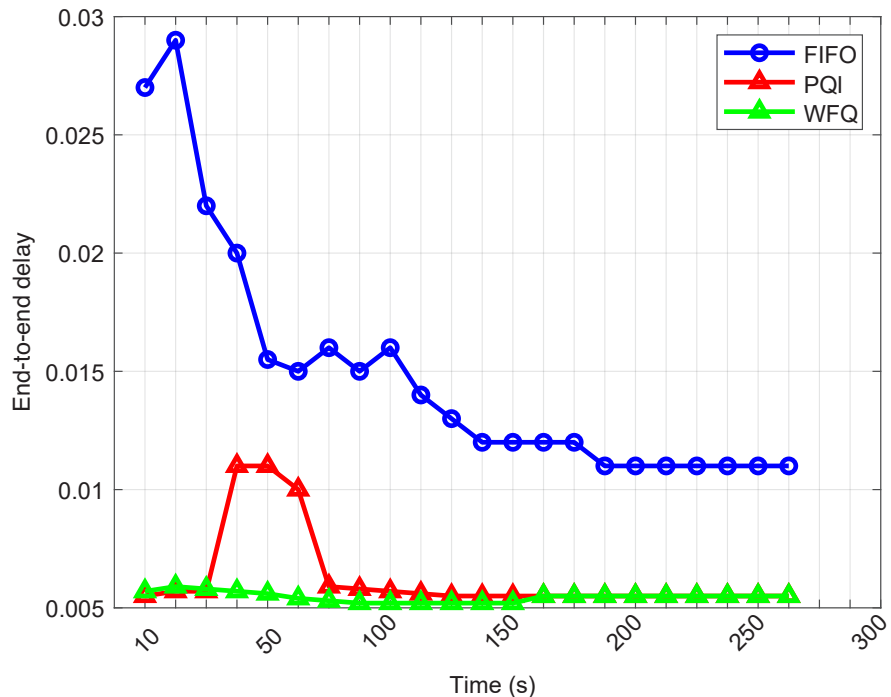

Fig. 4. Packet Delay Video Conference

**5.2. VoIP based Packet E2E and latency for FIFO, PQ, and WFQ**

The same process is carried out for VoIP services. VoIP services also assume two different parameters, including “end-to-end delay and latency” as depicted in Fig. 5, 6 respectively.

**5.3. Data dropped and throughput for FIFO, PQ and WFQ**

All services are tested for dropped data size as one of the parameters to see the amount of data that cannot be transmitted as shown in Fig. 7.

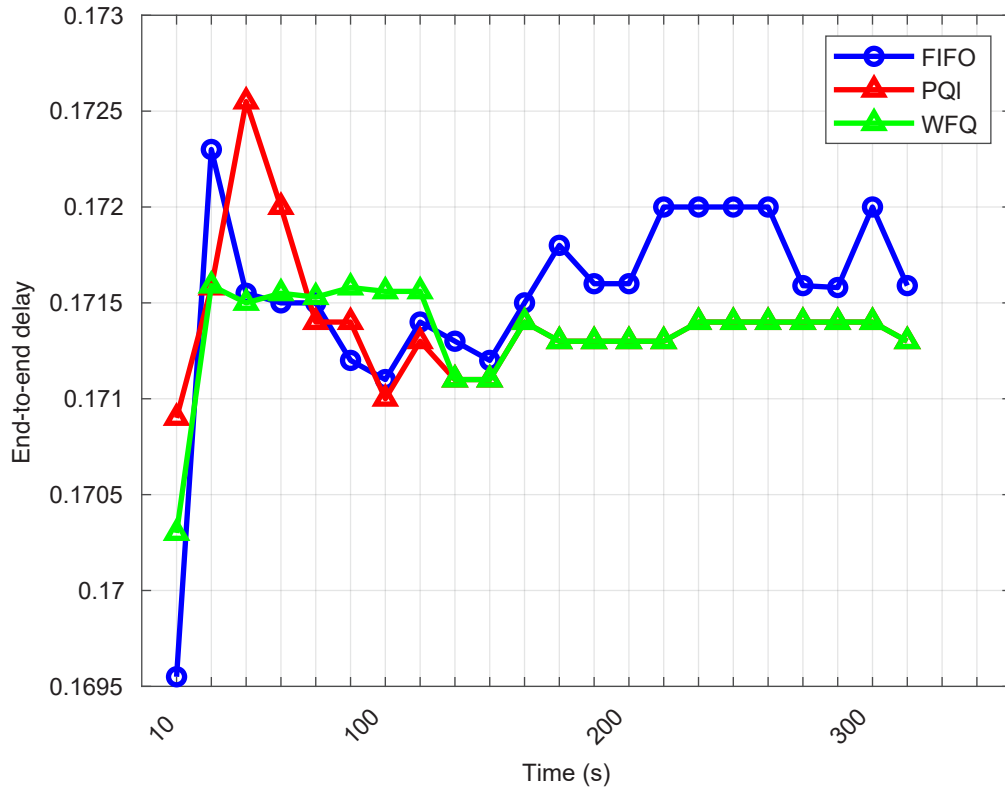

Fig. 5. Packet E2E delay on VoIP

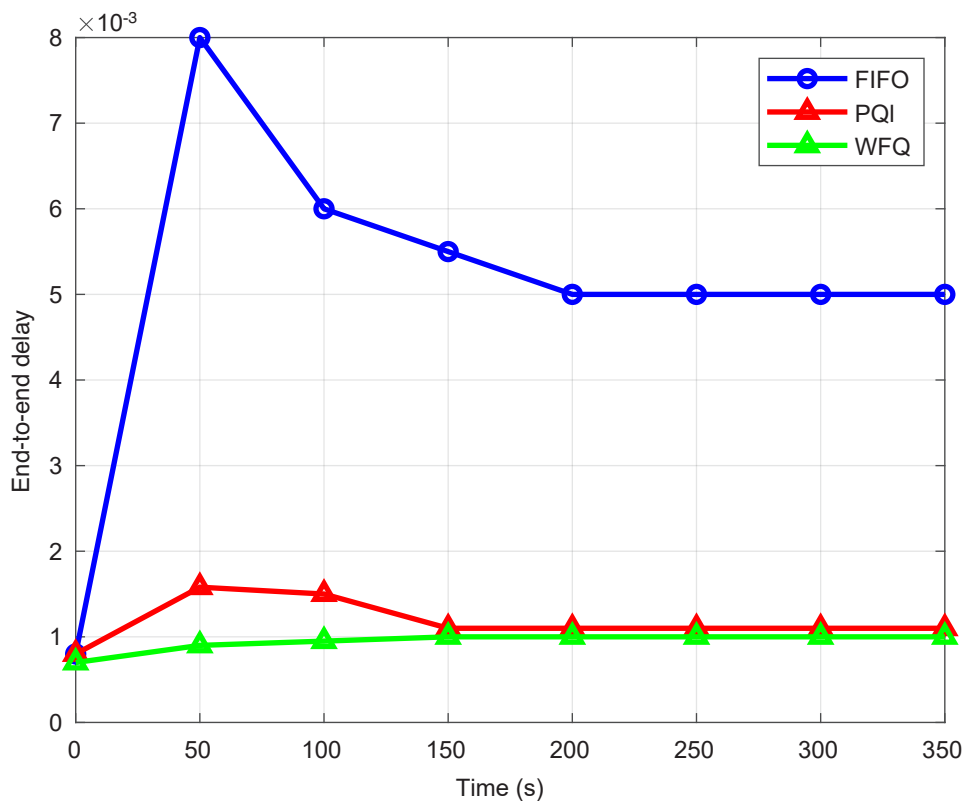

Fig. 6. Packet Delay Variation on VoIP

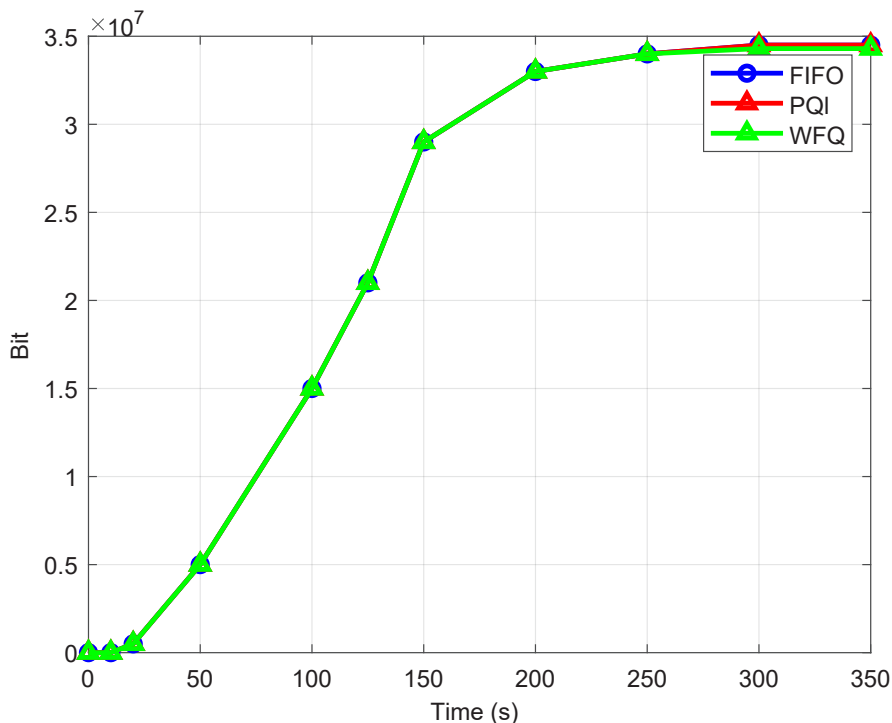

Fig. 7. Data Dropped

Another parameter considered in this study is throughput as depicted in Fig. 8.

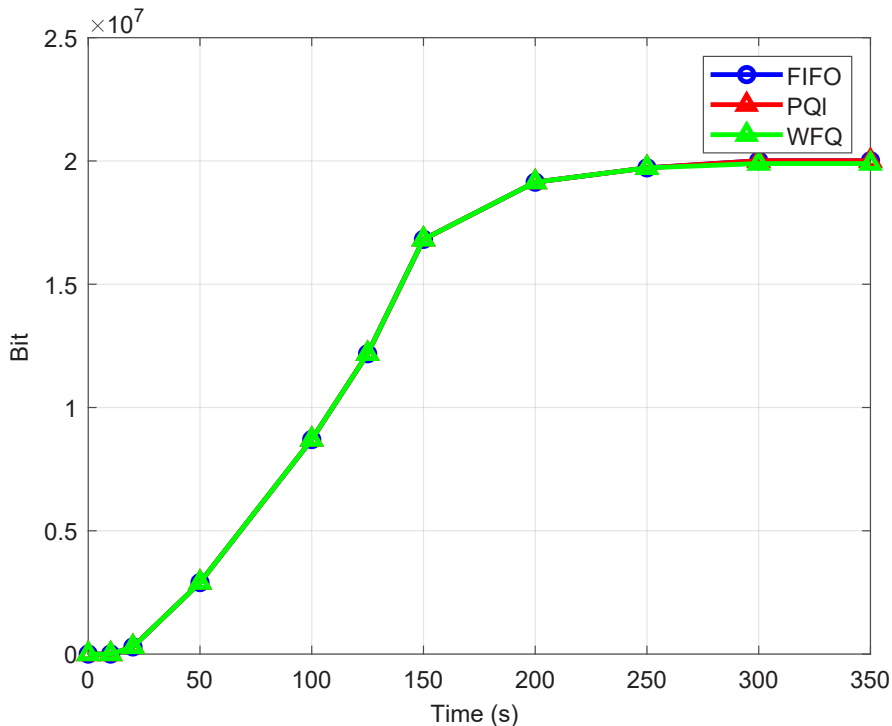

Fig. 8. Throughput

**6. Discussion of the results of traffic management on Wi-Fi**

The results explain traffic management on Wi-Fi STT Telematics Telkom network based on the best queuing mechanism among FIFO, PQ and WFQ, WFQ by analysis of

three services namely HTTP, FTP, and video based on throughput and delay for all the applications, while the jitter parameter is only tested in the video application. FIFO is influenced by the arrival time of data packets, whereas PQ and WFQ classify the types of traffic based on service priority. In addition, WFQ assigns fair weight to each service. The simulated service defines three different DiffServ Code Point (DS code point), namely Best Effort (BE) representing FTP, Assured Forwarding (AF) representing video conferencing, and Expedited Forwarding (EF) representing VoIP. From the above-mentioned queuing mechanisms, several queuing methods can be developed that are more specific in subsequent research.

The comparison curves in Fig. 1, 2 indicated that the queue buffer should be enlarged resulting in greater delay. If the shortest possible delay is necessary, the queue buffer length should be lowered. Furthermore, minimum data drop probability, it creates larger dropped data and vice versa. FIFO has the highest value, followed by PQ and WFQ, respectively.

The simulation results show the performance curves of different scenarios used differentiated with different colors. In addition to performance curves, the typical values were presented in the form of a datasheet, which aims to facilitate the view of the graph in the form of more detailed figures, making it easier to analyze to determine which queuing discipline is the best. Using the datasheet, further analysis was done by using the average value as reference data. The results interpreted from the datasheet were matched against the existing QoS standards of each service used, to check whether the required QoS is guaranteed. Table 6 lists the summary of the results.

From the above table, the WFQ has an E2E delay less than PQ and FIFO methods in all the services that were evaluated while the PQ method shows better results than the FIFO in the evaluated services. The feature of the proposed method can be applied directly to the real

world to produce maximum quality. The results are also compared against the QoS standard to determine the best. According to the comparison with exiting related work, Fig. 4, 5, indicated that FIFO has the highest delay and latency compared to PQ and WFQ, whereas WFQ has the lowest value.

Table 6

Summary of results

Service	Parameter	FIFO	PQ	WFQ
Video	Packet E2E delay	34.4897 ms	33.621 ms	33.5969 ms
		13.2898 ms	8.5316 ms	7.31848 ms
Confer- ence	Packet delay variation	172.89 ms	182.84 ms	18.282 ms
		1.12 ms	1.102 ms	0.988 ms
VoIP		2.101394 ms	2.12823 ms	7.20737ms

In addition to the inference, the comparison can be reviewed from the average conversion value from the datasheet shown in Table 3. The results corresponding to WFQ queue theory on end-to-end delay and latency have a value of 32.4959 ms, with matches with the set defined by ITU-T G.1010 and 7.20737 ms is the packet delay variation.

Thus, the delay and latency in WFQ have better entries compared to other queuing methods. This is because WFQ has a bandwidth allocation tailored to the needs. The bandwidth allocation is tailored to services that are sensitive to delay. Services that are more sensitive to delay is VoIP followed by video conferencing and FTP. The resulting delay is thus smaller, so WFQ is more efficient in Wi-Fi networks. Thus, the data dropped on WFQ is smaller compared to PQ and FIFO. The delay and latency in the case of WFQ have values of 171.71 ms and 0.977 ms, respectively. The value is in accordance with ITU-T G.1010 standard, which is an acceptable one. The system configured with WFQ experiences the highest throughput compared to FIFO and PQ. From Fig. 9 it is inferred that the throughput in the case of PQ falls between WFQ and FIFO. Higher throughputs better the quality. The bandwidth allocation is adjusted for delay-sensitive services, with a high throughput value of 2.017332804 Mbps.

This study did not mention traffic management such as queuing discipline, where different queuing mechanisms are considered to observe traffic management on the Wi-Fi STT Telematics Telkom network. However, this disadvantage can be investigated in future work in terms of performance parameters that remain the same while the jitter parameters

are tested in the video conferencing application. Therefore, in future work, we need to enhance the delay based on increasing the Wi-Fi transmission range by changing the protocol used and enhancing the delay based on increasing the Wi-Fi transmission range that will encounter interference problems.

7. Conclusions

1. Traffic management on the Wi-Fi STT Telematics Telkom network was observed by analyzing the performance of three commonly used queuing devices, including “First-In-First-Out (FIFO), Priority Queuing (PQ), and Weighted Fair Queuing (WFQ)”. FIFO queuing mechanism is influenced by the arrival time of data packets, where the delay, latency, and data dropped on FIFO are greater while the throughput is less than the others.

2. The queuing mechanisms used Priority Queuing (PQ), and Weighted Fair Queuing (WFQ) to classify the types of traffic based on service priority. The results show the delay and latency became small than using FIFO but WFQ has the lowest value. The data dropped on WFQ is smaller compared to PQ. The throughput in the case of PQ falls between WFQ and FIFO. The system configured with WFQ experiences the highest throughput compared to FIFO and PQ.

3. Three services namely HTTP, FTP, and video based on throughput and delay for all the applications were analyzed, while the jitter parameter is only tested in the video application. The results have shown the video conferencing services and VoIP services, WFQ queuing mechanism is the better choice considering packet delay and packet delay variation. In the case of video conferencing service configured with WFQ results in a delay with a value of 32.495 ms and variation in the delay with a value of 7.207 ms, whereas in the case of VoIP service, the packet delay is 171.717 ms and variation in the delay is 0.977 ms. This is because the WFQ has a bandwidth allocation tailored to the needs mentioned earlier.

References

1. Nwabueze, C. A., Akaneme, S. A. (2009). Wireless Fidelity (Wi-Fi) Broadband Network Technology: An Overview with Other Broadband Wireless Networks. *Nigerian Journal of Technology*, 28 (1), 71–78. Available at: <https://www.ajol.info/index.php/njt/article/view/123428>
2. Umoren, I. J., Inyang, S. J. (2021). Methodical Performance Modelling of Mobile Broadband Networks with Soft Computing Model. *International Journal of Computer Applications*, 174 (25), 7–21. doi: <https://doi.org/10.5120/ijca2021921157>
3. Najjari, N. (2017). Performance modeling and analysis of wireless local area networks with bursty traffic. Available at: <https://ore.exeter.ac.uk/repository/handle/10871/27588>
4. Hneiti, W., Ajlouni, N. (2006). Performance Enhancement of Wireless Local Area Networks. 2006 2nd International Conference on Information & Communication Technologies. doi: <https://doi.org/10.1109/ictta.2006.1684782>
5. Wattimena, G. M. (2013). Performance Analysis of Statistical Distributions for VoIP over WiMAX Access Networks. *International Journal of Advanced Research in Computer Science and Electronics Engineering (IJARCSEE)*, 2 (4), 372–376. Available at: [https://www.academia.edu/3422091/Performance\\_Analysis\\_of\\_Statistical\\_Distributions\\_for\\_VoIP\\_over\\_WiMAX\\_Access\\_Networks](https://www.academia.edu/3422091/Performance_Analysis_of_Statistical_Distributions_for_VoIP_over_WiMAX_Access_Networks)
6. Gabriel, B., Onuodu, F. E. (2021). An Improved Model For Wireless Fidelity Using Header Compression Algorithm (HCA). *International Journal of Innovative Information Systems & Technology Research*, 9 (3), 131–141. Available at: <https://seahipaj.org/journals-ci/sept-2021/IJIISTR/full/IJIISTR-S-13-2021.pdf>
7. Wing Ming Wong, E., Chi Hung Chan, S. (2001). Performance modeling of video-on-demand systems in broadband networks. *IEEE Transactions on Circuits and Systems for Video Technology*, 11 (7), 848–859. doi: <https://doi.org/10.1109/76.931111>



8. Singh, G. (2012). Comparative Analysis and Security Issues in Broadband Wireless Networks. *Global Journal of Research In Engineering*, 12 (8-F), 35–39. Available at: <https://engineeringresearch.org/index.php/GJRE/article/view/642/584>
9. Muntean, G.-M., Perry, P., Murphy, L. (2004). Performance Comparison of Local Area Video Streaming Systems. *IEEE Communications Letters*, 8 (5), 326–328. doi: <https://doi.org/10.1109/lcomm.2004.827451>
10. Mondal, D. C., Misra, I. S., Basu, S. (2012). Performance Evaluation of VoIP Codecs over WiMAX/WiFi Integrated Network. *International Journal of Computer Applications*, 0975 (8887), 14–17.
11. Abdelrazig, W. S., El Dawo, H. (2013). Performance Evaluation of VOIP Codecs Over Wi-Fi WIMAX. *International Journal of Science and Research (IJSR)*, 5 (8), 1924–1927. Available at: <https://www.ijsr.net/archive/v5i8/ART20161337.pdf>
12. Singh, J., Kumar, R., Kumar, M. (2012). Performance analysis of WiMAX with different modulation techniques. *International Journal of Engineering Research & Technology (IJERT)*, 1 (4), 1–6.
13. Fong, B., Hong, G. Y. (2010). On Performance of Multicast Delivery with Fixed WiMAX Telemedicine Networks Using Single-Carrier Modulation. *Journal of Advances in Information Technology*, 1 (1). doi: <https://doi.org/10.4304/jait.1.1.59-65>
14. Saeed, A. T., Esmailpour, A., Nasser, N. (2016). Performance analysis for the QoS support in LTE and WiFi. 2016 IEEE Wireless Communications and Networking Conference. doi: <https://doi.org/10.1109/wcnc.2016.7564685>
15. AlAlawi, K., Al-Aqrabi, H. (2015). Quality of service evaluation of VoIP over wireless networks. 2015 IEEE 8th GCC Conference & Exhibition. doi: <https://doi.org/10.1109/ieeegcc.2015.7060070>
16. Alturki, R., Nwizege, K., Mehmood, R., Faisal, M. (2009). End to End Wireless Multimedia Service Modelling over a Metropolitan Area Network. 2009 11th International Conference on Computer Modelling and Simulation. doi: <https://doi.org/10.1109/uksim.2009.90>
17. Sarkar, M., Goel, R. (2008). An Algorithm to Enhance QoS for Streaming Video over WLANs. *Advances in Electrical and Electronics Engineering - IAENG Special Edition of the World Congress on Engineering and Computer Science 2008*. doi: <https://doi.org/10.1109/wcecs.2008.18>
18. Sadiwala, R., Saxena, M. (2015). Performance Evaluation of Next Generation Networks using OPNET Simulator. *Communications on Applied Electronics*, 2 (4), 32–37. doi: <https://doi.org/10.5120/cae2015651737>