

*In this paper, the numerical simulation of the mechanical performance of a composite prosthetic keel structure under static load has been explored, and the findings of this inquiry have been included. The prosthetic keel is constructed from an epoxy and glass fiber composite, 3 percent weight (MWCNTs with SiC), and a carbon nanotube, which are utilized in conjunction with other materials to create the structure. The force that is applied in this example is 1,000 N, and it is applied in accordance with the boundary condition that has been previously established in this case. The ANSYS modeling software package was used to create the prosthetic keel model, which was meshed and created. Because of the total deformation, the fundamental simulation results of the prosthetic keel model have been converged in line with the total deformation, which was used as a reference to determine the total deformation. The major outcome of the current numerical analysis has been successfully validated by considering the findings of the earlier experimental study. The mechanical performance of the composite prosthetic keel structure is determined by four primary criteria, the results of which are based on the findings. Aspects to analyze include equivalent elastic strain, three-axis directed deformation, total deformation, and equivalent stress (von Mises). Although only 0.00058 mm total deformation is created by the imposed static load of 1,000 N (the least attainable value), it represents the largest total deformation. The equivalent stress (von Mises) responded to the load with a response of 0.045 MPa, which is quite small. Furthermore, the equivalent elastic strain has also been undertaken and it resulted in a value of elastic strain of  $3.4 \times 10^{-7}$*

**Keywords:** *von Mises stress, directional deformation, total deformation, equivalent elastic strain, FEM*

UDC 621  
DOI: 10.15587/1729-4061.2022.256943

# INVESTIGATION OF THE MECHANICAL PERFORMANCE OF THE COMPOSITE PROSTHETIC KEEL BASED ON THE STATIC LOAD: A COMPUTATIONAL ANALYSIS

**Kussay Ahmed Subhi**  
Corresponding author  
Senior Lecturer\*

E-mail: kussaysubhi@atu.edu.iq

**Emad Kamil Hussein**  
Assistant Professor\*

**Haider Rahman Dawood Al-Hamadani**  
Senior Lecturer\*

**Hussein Kadhim Sharaf**  
Researcher

Department of Air Conditioning and Refrigerating  
Dijlah University College  
Al-Masafi str., Baghdad, Iraq, 10021

\*Department of Mechanical Equipment Engineering  
Al-Mussaib Technical College TCM  
Al-Furat Al-Awsat Technical University ATU  
Al-Mussaib, Babil, Iraq, P.O. Box 51006

Received date 07.04.2022

Accepted date 07.06.2022

Published date 30.06.2022

**How to Cite:** Subhi, K. A., Hussein, E. K., Al-Hamadani, H. R. D., Sharaf, H. K. (2022). Investigation of the mechanical performance of the composite prosthetic keel based on the static load: a computational analysis. *Eastern-European Journal of Enterprise Technologies*, 3 (7 (117)), 22–30. doi: <https://doi.org/10.15587/1729-4061.2022.256943>

## 1. Introduction

According to recent systematic studies, prosthetic stance-phase mechanical features can have a significant impact on lower-limb amputation rehabilitation results (e.g., walking dynamics and metabolic economy). End-user biomechanical performance can be better understood by measuring the mechanical parameters of a prosthetic device without involving the user. A shoe is almost always worn with a prosthetic foot, although the impact of different shoes on prosthetic foot performance is poorly understood. Shoe choice affects an end-user device that has been therapeutically adjusted based on a patient's mobility and health, but little research has been done on the impact of shoe choice on the functional purpose of prosthetic feet. Patients aren't getting the full advantage of prosthetic components because clinicians don't know if they're getting the

most out of their prosthetics. Classifying prosthetic feet due to their functional qualities has recently been standardized, and these rules have been utilized to aid in the interpretation of results from biomechanical comparison studies. Displacement and energetic return under specified load amplitude and directions are used to classify prosthetic feet according to their mechanical function in the suggested classification scheme (e.g. dynamic and multiaxial). There may be a mismatch between the outcome behavior and the original classification assignments aimed to simplify clinical component recommendations when specific shoes are added to the prosthetic foot.

A complex model in geometry is always necessary for a complex function. Using complicated geometry prosthetics is necessary to mimic the human foot's functionality. As a result, accurate modeling of prosthetics is critical. Before any foot prosthesis modeling can be done, it is imperative

that the typical biomechanics of the foot be understood. A biomechanical behavior includes information on the internal stresses and strains on the foot and ankle. These variables are difficult to measure, but a computer model can provide the necessary information. Prosthetic software on the market, such as Infinity CAD systems AutoScanner & AutoSculpt [1], are commonly used in obtaining data necessary for developing or altering prostheses. There are a variety of 3D scanners, such as Biosculptor's BioScanner, BioShape Software and DSS Digital Socket System [2]. Only the companies who manufacture the CAD/CAM prosthetic software really use it to create new prosthetic components [3]. Many researchers turned to computational tools in their search for additional clinical data in order to extend the results of inadequate experiments [4]. Computer-aided design, such as the finite element method, has proven to be a powerful tool for researchers due to its ability to model structures with irregular geometry [5], properties of materials, and because it can easily represent complex boundary conditions and loads in both static and dynamic analyses [6]. Numerous factors, including load distribution, stress, strain, and absorbed energy, can be predicted using FE methods in foot simulations with various loads and supports [7]. A successful FE analysis began with a geometry model that was appropriate and successful, and that satisfied all of the design specifications [8]. The ankle-foot group moves in a variety of ways and does not always remain in the same position. Extensive motion is possible at both ankle and subtalar joints in both directions.

Calculating the stress-strain behavior of lower limb prosthetic devices was accomplished by [9] with the help of FEM. In addition to that, the FEM has been utilized in the process of forecasting the peak voltage. Motions, both normal and pathological. As well as stress on the AFO With the intention of performing structural analysis. There has been no consideration given to the material's microscopic structure. Carbon fiber, on the other hand, presents an entirely different scenario in the works that were just mentioned. When designing reinforced plastics, it is imperative that macro-scale impacts of microstructure be taken into consideration (CFRPs). There was more than one strategy suggested. Must come up with a way to fix this problem. Methods such as the asymptotic homogenization approach for periodic structures and the FE method are included in this category [10–12]. Included in the highlights are [13, 14]. In order to take into account microstructure, an anisotropic model might be utilized. A model of the material world that is predicated on the concept of structural tensors. The majority of the time in the infinite stresses that such models were established in the finite stresses of the anatomy and physiology of the human body. The prosthetic foot-shoe system features can be significantly influenced by the patient's functional level, so a clinician can choose a suitable prosthetic foot by matching precisely constructed prosthetic foot characteristics with the patient's functional level [15].

Therefore, studies devoted to the development of the nanocarbon tube to be used as an additive fabricated with epoxy and glass fiber for the prosthetic keel structure are of scientific relevance. The prosthetic keel structure will be numerically investigated in terms of mechanical performance.

---

## 2. Literature review and problem statement

---

Previous studies such as [16] have reported that the prosthetic stance-phase mechanical features can have a sig-

nificant impact on lower-limb amputation rehabilitation results (e.g., walking mechanics and metabolic economy), according to recent systematic investigations. Quantifying a prosthetic device's mechanical qualities independent of its wearer, understanding the biomechanical performance of the end-user is critical. A shoe is almost always worn with a prosthetic foot, although the impact of different shoes on prosthetic foot performance is not well studied. For example, a doctor might select a patient's prosthetic foot based on the functional level and then have that patient's choice of shoes drastically affects the prosthetic foot-shoe system's performance. Shoe choice affects end-user devices clinically tailored for patient mobility and health state but has received less attention in the academic literature due to its influence on the mechanical prosthetic foot function according to [17]. The results of [18] show that clinicians do not know if their patients are getting the full advantage of prosthetic devices so that they can maximize their rehabilitation potential. Standard guidelines for the classification of prosthetic feet based on their functional properties have recently been established, and these standards have been utilized to help interpret the results of biomechanics comparative studies. Displacement and energy recovery under specified load order of magnitude and directions are used to classify prosthetic feet according to their mechanical function in the suggested classification scheme (e.g. dynamic and multiaxial) [19]. As a result, the addition of particular shoes may alter the mechanical function of the prosthetic foot in such a dramatic way that it conflicts with the original classification assignments aimed at facilitating clinical component recommendations. However, a 25-year investigation on the mechanical characteristics of prosthetic feet and footwear highlighted the need for bench-top methodologies to quantify the material properties of prosthetic feet and shoes in order to improve our understanding of these combined effects on walking performance. Only sagittal-plane impacts like rollover shape and heel viscoelastic characteristics have been examined in the van Jaarsveld and other studies [20]. Many various activities in [21] can be performed with a single type of prosthetic foot, therefore understanding how the prosthetic foot operates in different shoes is critical to the prescription process. For biomechanical comparisons of prosthetic versus non-prosthetic feet, poorly characterized interactions between footwear or prosthetic foot material properties can have a significant impact on clinical outcomes. Prosthetic feet have previously been shown to be compromised by the addition of footwear, which could lead to equivocal findings in comparison studies if this variable is not controlled. The typical biomechanics of the foot and ankle, including the internal stresses and strains that make up their biomechanical behavior, must be thoroughly understood before any foot prosthesis models can be applied. A computer model is typically employed to get this vital information because it is difficult to measure these factors directly. Many types of prosthetics can be developed or modified using CAD/CAM software, which is widely accessible on the market. Options include Infinity CAD systems. These CAD/CAM prosthetics applications, on the other hand, tend to be used only by the companies who make them to manufacture prosthetic components [22]. Many researchers have shifted to analytical modeling in an effort to obtain more clinical information in the face of insufficient experimental outcomes. In static and dynamic analysis, computational modeling, particularly FEM modeling, has proven extremely useful for many researchers due

its ability to model structures with irregular geometries and complex material properties, as well as its straightforward representation of complex initial conditions and loads have been reported in [23]. A wide range of characteristics can be predicted using FE methods, including load distribution, stress, strain, and the absorbing energy of an ankle-foot structure under varying loads and supports. It all begins with the correct and successful geometric modeling that meets all design standards [24].

Thus, in this study, the mechanical performance of the composite prosthetic keel based on the static load has been investigated numerically.

### 3. The aim and objectives of the study

The aim of the study is to investigate the mechanical performance of the composite prosthetic keel based on the static load using a computational analysis method.

The following objectives have been set to achieve the aim:

- to investigate equivalent elastic strain;
- to calculate directional deformation;
- to calculate the total deformation of the composite prosthetic keel due to static load;
- to investigate the equivalent stress (von Mises) of the composite prosthetic keel due to static load.

### 4. Materials and methods

#### 4.1. Boundary conditions

Beginning with the boundary restrictions as to its only constraints, the composite prosthetic keel experiences no load while being confined by the constraints of its surroundings. The same limitations and boundary conditions that were applied in the first phase are applied in the final step of this FEA. The loading device has a limit of 1,000 N in terms of force as shown in Fig. 1.

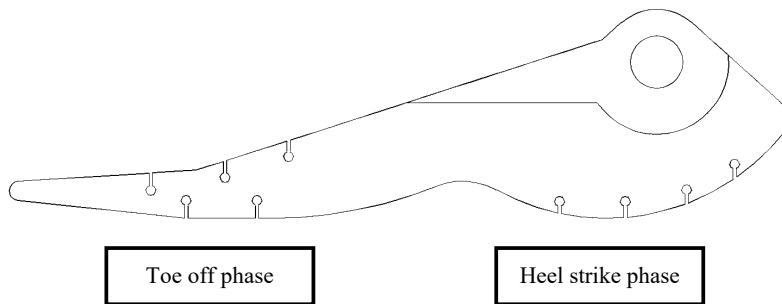

Fig. 1. Boundary conditions

According to the ground reaction forces shown in Fig. 1, at the mid-stance phase of each of the three phases, the amputee's total body weight was roughly 1.2 times the ground response force.

#### 4.2. Mechanical properties of multi-wall carbon nanotubes (MWCNTs)

In this work, a composite prosthetic keel has been previously manufactured experimentally and used in the research. MWCNTs (multi-wall carbon nanotubes) are a type of carbon nanotubes that have been used and defined in the ANSYS software database. The mechanical properties of

composite materials are depicted in Table 1. As a result of the simulation method, the required mechanical properties have been gathered. As is well known, the passion to action ratio in the simulation analysis, the modulus of elasticity and density are key properties to know about.

Table 1

Mechanical properties of the composite structure of the prosthetic keel

Function	Additive weight	Passion ratio	Modulus of elasticity	Density
Units	N/A	Unitless	MPa	g/cm <sup>3</sup>
Materials	3 %	0.3	2.1349	1.615

Glass fiber and epoxy are among the materials that have been used, and nanoparticles have also been included in order to improve the mechanical performance of the prosthetic keel structure. The following is the final composition of the composite structure of the prosthetic keel (epoxy+glass fiber+3 % weight (MWCNTs+SiC)).

#### 4.3. Meshing and geometry

Geometry has been constructed using the AutoCAD software for the purposes of this research. The Ansys software suite was used to create the geometry and render the final product. A tool called Space Claim was used to construct the geometry for this piece of work as shown in Fig. 2.

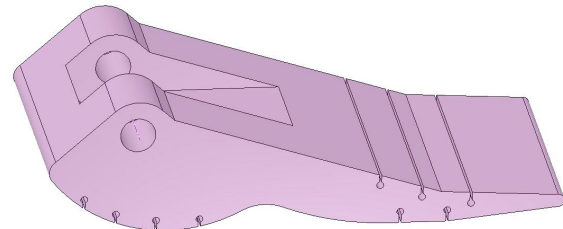

Fig. 2. Model of the composite prosthetic keel structure

Using commercial software, it is possible to do research on computational fluid dynamics (CFD). Informally referred to as Fluent, it is a widely used tool for modeling and simulating fluid flows and heat transfers in order to solve fluid equations and create the necessary answers as seen in Fig. 3. In order to construct and apply the mesh on a geometric representation of the problem in ANSYS, a pre-processor software package is used.

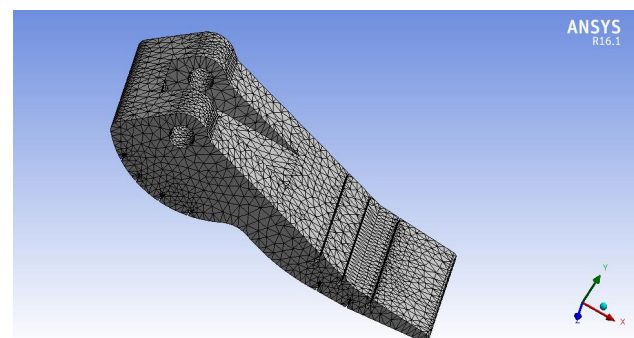

Fig. 3. Meshed model of the composite prosthetic keel structure

Fluent is in control of the process's pre-processing and post-processing phases, which are both under its oversight. It is used in challenging sections of the meshed model to use Pavement components of the Tri-type, but it is utilized in other parts of the model to use the Pavement component of the Quad-type (Fig. 3). In Fluent, it is possible to generate amorphous meshes, and the grid can be polished or roughened based on the flow solution that is being considered. With the help of a macro, it was feasible to import the grid data into Fluent from a spreadsheet.

**4. 4. Convergence study**

Total deformation has been employed as the primary indicator for the convergence test in this study, and the test was initiated using 34,953 elements and 60,899 nodes to begin with. During the first try, there were 54,862 elements and a total of 90,789 nodes. This resulted in a change ratio of 14.99 percent. The change ratios were drastically reduced from 29.6 percent to 4.2 percent in a short period of time. There are 360,337 elements and 530,481 nodes in this study, with a change ratio of 4.26 percent, and it has been converged.

Fig. 4 depicts the change that occurred as a result of the attempted use of the primary indicator (Total deformation). With an increase in the number of elements, the total deformation values were only minimally altered. It was initially set at 0.93 mm and has now been increased to 2.022 mm. With 360,337 elements in total, the overall study has been converged to a maximum change ratio of 4.2 percent.

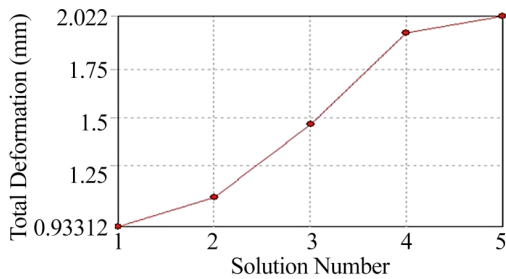

Fig. 4. Convergence analysis due to total deformation

Five solutions have been carried out to reach the optimum convergence level of the mesh. Total deformation has been considered as the main indicator of this process. The model has been converged at a value of 2.022 mm of the total deformation of the composite prosthetic keel.

**4. 5. Validation of the numerical results**

[25] has been used as a reference for the current simulation process of the applied static load on the prosthetic keel in order to verify and validate the results of the current simulation process of the applied static load on the prosthetic keel. Total deformation has been chosen as the primary metric to compare results in this instance. At 1,000 N, the simulation has been validated using the identical boundary condition as in the prior study. With a confidence level of 91 percent, the simulation study demonstrated that the results were reliable. It is practical to accept a percentage of resemblance between numerical and experimental work in order to proceed with the next step in the process.

**5. Results of the mechanical performance of the composite prosthetic keel**

**5. 1. Equivalent elastic strain**

Using the equivalent elastic strain approach, as depicted in Fig. 5, this research investigated the overall mechanical performance of the composite prosthetic keel. A graphical representation of the static structural analysis has been constructed and described with the help of a legend. The maximum electric strain has been calculated by applying the maximum applied loads of 1,000 N to a given voltage and current. It was determined that the maximum electric strain could be achieved by applying the maximum load of 1,000 N. It was determined that the value of elastic strain was inaccurate. A value of  $3.4 \times 10^{-7}$  has been obtained, which is quite high.

The equivalent elastic strain of the composite prosthetic keel has been investigated accordingly in the Ansys software. Graphical illustration has shown all the effects of the load on the entire body of the keel.

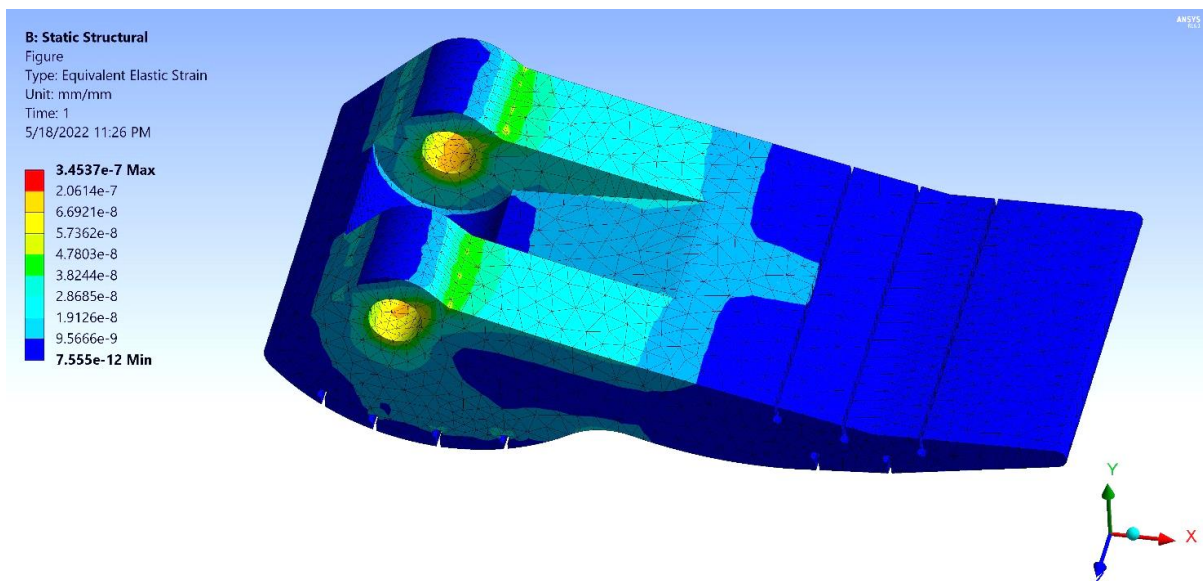

Fig. 5. Equivalent elastic strain of the composite prosthetic keel

**5. 2. Directional deformation**

As illustrated in Fig. 6, the three maximum directional deformations were estimated in the three-axis space. According to the computational results, the greatest amount of deformation occurred along the Z-axis, with a value of 0.00093 mm in the process. When considering vertical deformation, the Y-axis has been viewed as a function of time. Because of the applied static load, the Y-axis experiences a directed distortion of 0.00057 millimeters in the Y-direction. The function of the X-axis has also been used to explore the directed distortion in the vertical direction. Directional deformation is measured at the X-axis and has a maximum value of 0.00011 at this location.

Accordingly, three alternative values of the directional deformation were determined in this manner. The static load applied was 1,000 N. Using the same boundary conditions, they have been compared in the appropriate way.

Fig. 7 showed the graphical illustrations of the maximum directional deformation on the horizontal plane with the X-axis. These results have been computed using a static structure tool in Ansys software. The simulation results have

stated that the maximum value of the deformation on the axis reached 0.00019 mm.

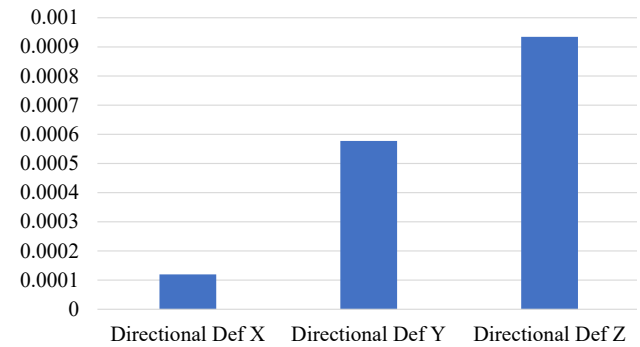

Fig. 6. Directional deformation of the composite prosthetic keel due to static load with respect to three axes

Illustrations of the greatest directional deformation on the vertical plane with the Y-axis are shown in Fig. 8, which is a graphical illustration.

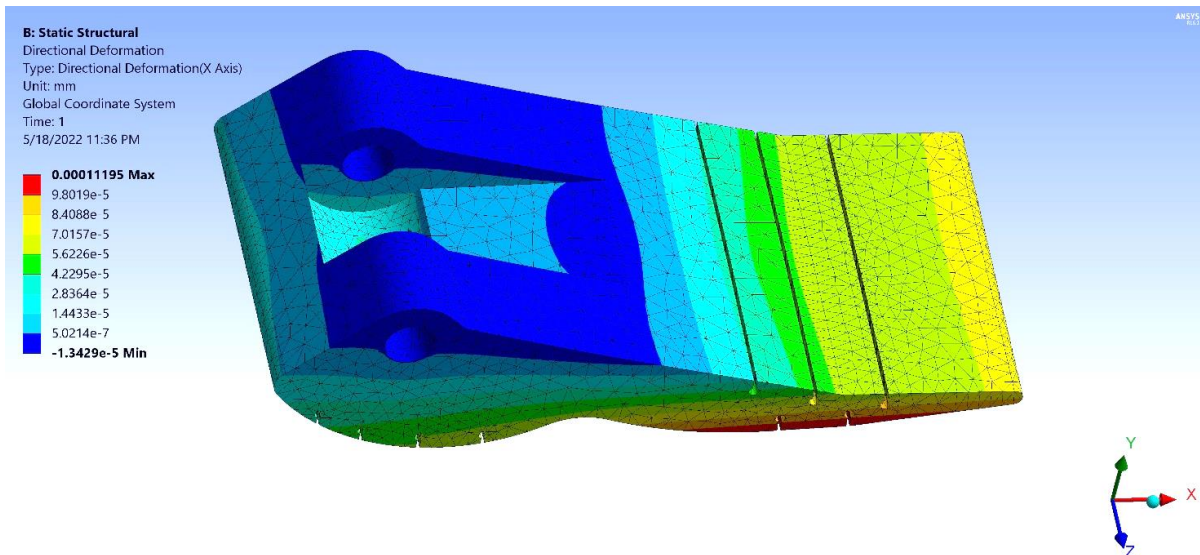

Fig. 7. Graphical illustration of directional deformation on the X-axis

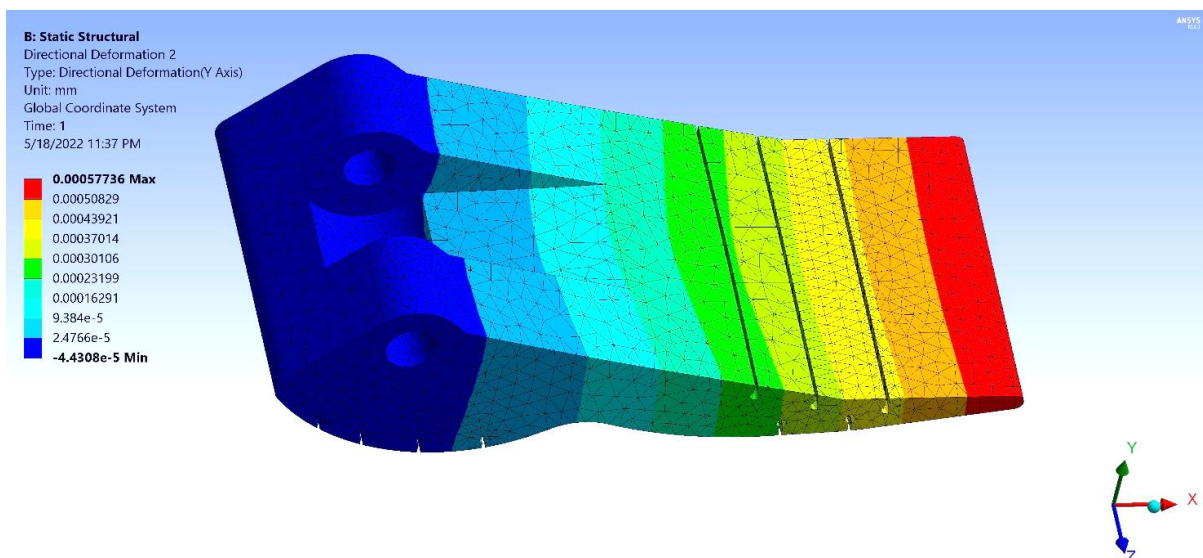

Fig. 8. Graphical illustration of directional deformation on the Y-axis

Using the Ansys program, a static structure tool was used to compute the data presented here. The numerical simulation results showed that the largest possible value of the axis deformation was 0.00057 millimeters.

Illustrations of the greatest directed deformation on a diagonal plane with the Z-axis are shown in Fig. 9, which included graphical representations of the deformation. These results were obtained using a static structure tool in the Ansys software package. It was determined from the simulation results that the highest value of the deformation along the axis was equal to 0.00093 millimeters.

Directional deformations in all directions have been all defined and investigated numerically. This has been carried out using a static structure tool in ANSYS software.

**5. 3. Total deformation**

The total deformation caused by the applied load was determined in this examination in accordance with the findings of this study. At the most extreme point of the model's behavior, the simulation results show that the maximum value of total deformation is 0.00058 mm at the most severe point

of the simulation results. These calculations were carried out with the assistance of a static structure tool using the ANSYS software package. The composite structure of the prosthetic keel is represented in Fig. 10, which illustrates how the composite structure is affected by the applied load.

Modeling and evaluation of the composite prosthetic keel have been carried out using finite element methods in the proper manner. It was decided to conduct this inquiry in accordance with the boundary requirements that had been established by the previous investigations. At this time, a static load of 1,000 N has been applied, with the maximum imposed load being equivalent to the existing state.

**5. 4. Equivalent stress (von Mises)**

Equivalent von Mises stress, as shown in Fig. 11, was employed in this study to evaluate the composite prosthetic keel's overall mechanical performance. Graphic representations of static structural analysis have been demonstrated and described in this part with the help of an illustration. For a particular voltage and current combination, applying the maximum applied loads of 1,000 N results in the most electric strain.

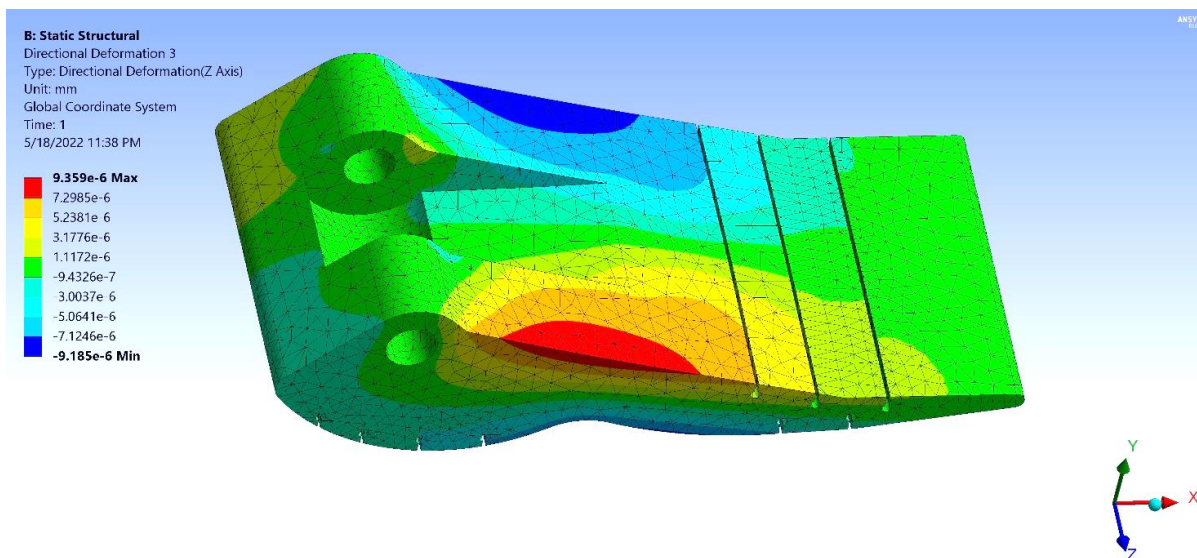

Fig. 9. Graphical illustration of directional deformation on the Z-axis

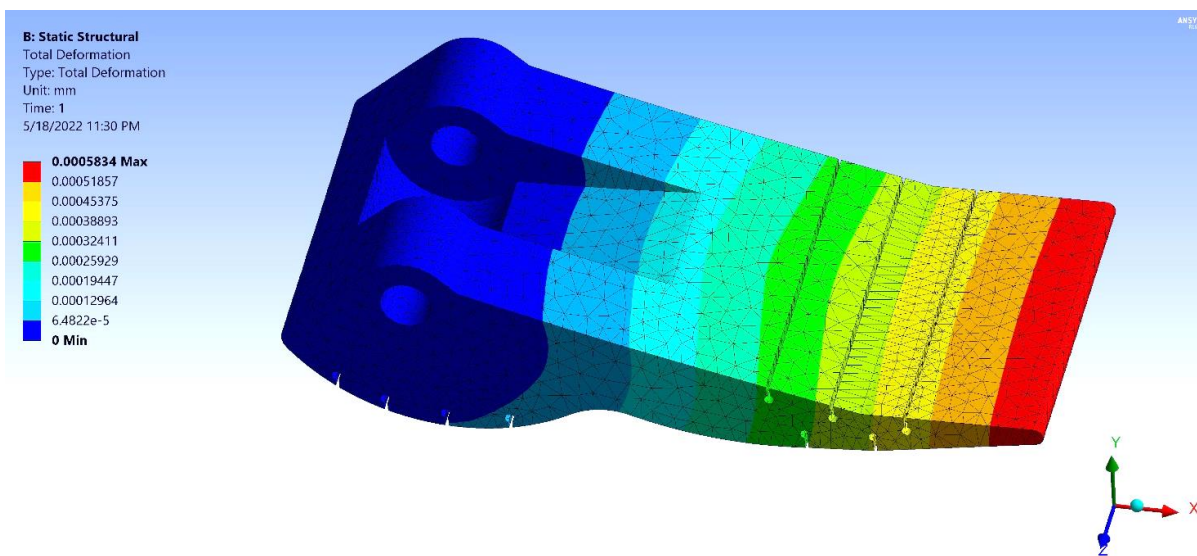

Fig. 10. Total deformation of the composite prosthetic keel due to static load

According to the results of this investigation, the greatest amount of electric strain may be experienced when applying the maximum load of 1,000 N. The computed elastic strain was found to be incorrectly calculated. It has a value of 0.045 MPa in this situation, which is remarkable.

The equivalent von Mises technique, as depicted in Fig. 12, was used in this study to investigate the overall mechanical performance of the composite prosthetic keel. In this section, it has been demonstrated and described with the assistance of an illustration how to produce a graphical representation of the static structural analysis. It has been discovered that applying the maximum applied loads of 1,000 N to a given voltage and current combination will result in the greatest amount of electric strain. According to the findings of this study, applying the maximum load of 1,000 N may result in the greatest amount of electric strain being experienced. It was determined that the value of elastic strain had been calculated improperly. In this case, an exceptionally high value of 0.045 MPa has been obtained.

The accurate modeling and evaluation of the composite prosthetic keel were accomplished using FEM techniques. Following the precedents established by the previous investigations, it was agreed that this investigation would be conducted within those parameters as well. It takes a static force of 1,000 N to maintain the existing state of affairs, which is the maximum force that can be applied.

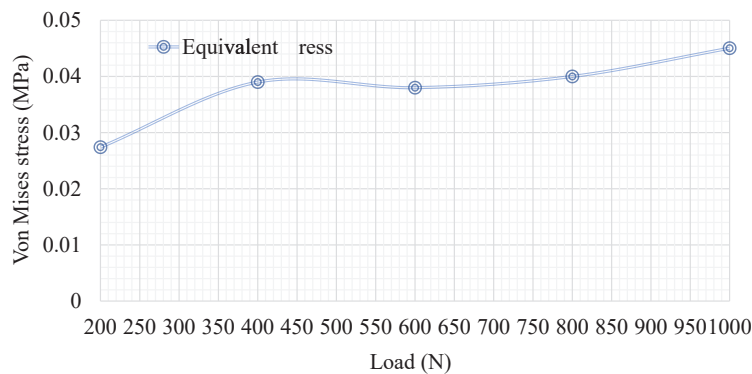

Fig. 11. Equivalent stress (von Mises) of the composite prosthetic keel due to static load

### 6. Discussion of the mechanical performance of the composite prosthetic keel

The current results explained the mechanical performance of the composite prosthetic keel based on the static load using the finite element method. Finite element methods have been established to be investigated using Ansys software to investigate the mechanical performance of the prosthetic keel. The numerical results of this study have been validated with the previous study accordingly.

It has been determined what the equivalent elastic strain is by utilizing a technique with a constant static load. According to the results obtained, the maximum value of the equivalent elastic strain is  $3.4 \cdot 10^{-7}$ , which is deemed to be quite high, as illustrated in Fig. 5. In Fig. 6, directional deformation has been calculated in three axes (X, Y, and Z) to demonstrate how this is done. It was discovered by the numerical results that the greatest amount of deformation occurred along the Z-axis, with a value of approximately 0.00093 mm in Fig. 7–9. As illustrated in Fig. 10, 11, the overall deformation in the Y-axis is 0.00057 mm, and the total deformation in the X-axis is 0.00011 mm. This study calculated the total deformation of the composite prosthetic keel as a result of a static load. The results of the simulation reveal that the maximum total deformation is 0.00058 mm, which is the smallest possible value. The equivalent stress (von Mises) of the composite prosthetic keel as a result of the static load is calculated. Fig. 11 depicts

the results of the investigation into equivalent elastic strain. As shown in Fig. 12, the simulation results suggest that the maximum value of equivalent stress is 0.045 MPa.

As previously stated, the primary problem is that the numerical investigation of the mechanical performance of the composite prosthetic keel based on the static load has not been completed. Aiming to improve mechanical performance, it has been studied in depth. In this case, the output of the numerical results has been given in the appropriate manner.

This system has a significant advantage in that it addresses a real problem in the mechanical performance of a composite prosthetic keel utilizing a modeling technique based on the boundary conditions that have been established.

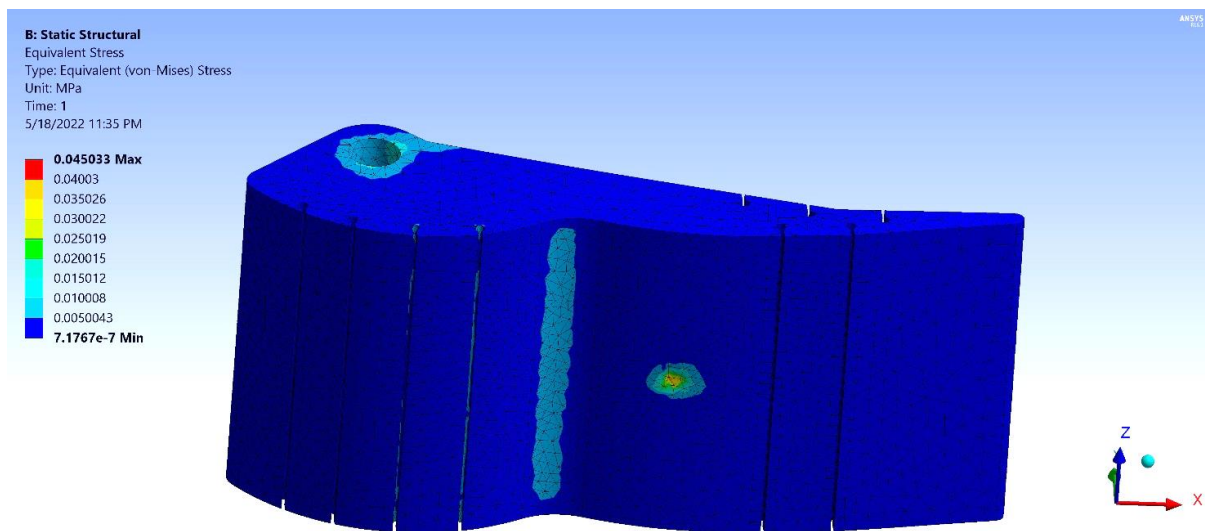

Fig. 12. Graphical illustration of equivalent stress (von Mises)

The scope of this study is limited to a specified range of static load 1,000 N and a specific sort of mesh configuration. MWCNTs (multi-wall carbon nanotubes) are also used in the keel manufacturing process. The output of the numerical analysis that has been taken into consideration is specified.

There are various disadvantages that can be observed, the most notable of which are as follows: the mesh of the engineering model can be improved even further. In addition, the results of this study have been compared to experimental data, and in that case, a percentage of error has been calculated. In this study, the composite prosthetic knee mechanism has been designed and numerically examined to determine its performance. The most challenging problem that has been encountered is how to configure the software such that it can be fitted with realistic boundary conditions. In addition, there are other boundary conditions, such as how to specify new materials in the software's library of materials.

## 7. Conclusions

1. Equivalent elastic strain has been investigated using the approach with a static load. The maximum value of the equivalent elastic strain of  $3.4 \times 10^{-7}$  has been obtained, which is considered quite high.

2. Directional deformation has been calculated in three axes (*X*, *Y* and *Z*). The numerical results revealed that the greatest value of deformation occurred along the *Z*-axis, with a value of 0.00093 mm. The total deformation in the *Y*-axis is 0.00057 mm, as well as 0.00011 in the *X*-axis.

3. Total deformation of the composite prosthetic keel due to static load has been calculated. The simulation results show that the maximum value of overall deformation is 0.00058 mm.

4. The equivalent stress (von Mises) of the composite prosthetic keel due to static load equivalent elastic strain was investigated. The simulation results show that the maximum value of equivalent stress is 0.045 MPa.

## References

- Santana, J. P., Beltran, K., Barocio, E., Lopez-Avina, G. I., Huegel, J. C. (2018). Development of a Low-Cost and Multi-Size Foot Prosthesis for Humanitarian Applications. 2018 IEEE Global Humanitarian Technology Conference (GHTC). doi: <https://doi.org/10.1109/ghtc.2018.8601851>
- Hamzah, M., Gatta, A. (2018). Design of a Novel Carbon-Fiber Ankle-Foot Prosthetic using Finite Element Modeling. IOP Conference Series: Materials Science and Engineering, 433, 012056. doi: <https://doi.org/10.1088/1757-899x/433/1/012056>
- Anane-Fenin, K., Akinlabi, E. T., Perry, N. (2019). Optimization Methods for Minimizing Induced Stress During Tensile Testing of Prosthetic Composite Materials. Advances in Mechatronics and Mechanical Engineering, 180–206. doi: <https://doi.org/10.4018/978-1-5225-8235-9.ch008>
- Hussein, E. K., Subhi, K. A., Gaaz, T. S. (2021). Effect of Stick - Slip Phenomena between Human Skin and UHMW Polyethylene. Pertanika Journal of Science and Technology, 29 (3). doi: <https://doi.org/10.47836/pjst.29.3.06>
- Prost, V., Peterson, H. V., Winter, A. G. (2021). Multi-Keel Passive Prosthetic Foot Design Optimization Using the Lower Leg Trajectory Error Framework. Volume 8A: 45th Mechanisms and Robotics Conference (MR). doi: <https://doi.org/10.1115/detc2021-67673>
- Mohammed, S. karim. (2021). Design and Manufacturing of a New Prosthetic Foot. Journal Port Science Research, 4 (2), 109–115. doi: <https://doi.org/10.36371/port.2020.2.8>
- Subhi, K. A., Hussein, E. K., Al-Jumaili, S. A. K., Abbas, Z. A. (2022). Implementation of the numerical analysis of dynamic loads on the composite structure employing the FE method. Eastern-European Journal of Enterprise Technologies, 1 (7 (115)), 42–47. doi: <https://doi.org/10.15587/1729-4061.2022.253545>
- Lecomte, C., Ármannsdóttir, A. L., Starker, F., Tryggvason, H., Briem, K., Brynjólfsson, S. (2021). Variable stiffness foot design and validation. Journal of Biomechanics, 122, 110440. doi: <https://doi.org/10.1016/j.jbiomech.2021.110440>
- Baharuddin, M. H., Ab Rashid, A. M., Nasution, A. K., Seng, G. H., Ramlee, M. H. (2021). Patient-specific design of passive prosthetic leg for transtibial amputee: Analysis between two different designs. Malaysian Journal of Medicine and Health Sciences, 17 (4), 228–234. Available at: [https://medic.upm.edu.my/upload/dokumen/2021100809555732\\_MJMHS\\_0119.pdf](https://medic.upm.edu.my/upload/dokumen/2021100809555732_MJMHS_0119.pdf)
- Subhi, K. A., Tudor, A., Hussein, E. K., Wahad, H., Chisiu, G. (2018). Ex-Vivo Cow Skin Viscoelastic Effect for Tribological Aspects in Endoprosthesis. IOP Conference Series: Materials Science and Engineering, 295, 012018. doi: <https://doi.org/10.1088/1757-899x/295/1/012018>
- May, C., Egloff, M., Butscher, A., Keel, M. J. B., Aebi, T., Siebenrock, K. A., Bastian, J. D. (2018). Comparison of Fixation Techniques for Acetabular Fractures Involving the Anterior Column with Disruption of the Quadrilateral Plate. Journal of Bone and Joint Surgery, 100 (12), 1047–1054. doi: <https://doi.org/10.2106/jbjs.17.00295>
- Daniele, B. (2020). Evolution of prosthetic feet and design based on gait analysis data. Clinical Engineering Handbook, 458–468. doi: <https://doi.org/10.1016/b978-0-12-813467-2.00070-5>
- Kokz, S. A., Alher, M. A., Ajibori, H. S. S., Muhsin, J. J. (2021). Design and Analysis of a Novel Artificial Ankle-Foot Joint Mechanism. IOP Conference Series: Materials Science and Engineering, 1067 (1), 012140. doi: <https://doi.org/10.1088/1757-899x/1067/1/012140>
- Kaluf, B., Cox, C., Shoemaker, E. (2021). Hydraulic- and Microprocessor-Controlled Ankle-Foot Prostheses for Limited Community Ambulators with Unilateral Transtibial Amputation: Pilot Study. JPO Journal of Prosthetics and Orthotics, 33 (4), 294–303. doi: <https://doi.org/10.1097/jpo.0000000000000369>



15. Khandagale, B. D., Pise, U. V. (2022). Numerical and experimental investigation of hinged Ankle-Foot-Orthoses (AFO) using composite laminate material for Cerebral Palsy patient. *Materials Today: Proceedings*. doi: <https://doi.org/10.1016/j.matpr.2022.02.554>
16. Sharaf, H. K., Ishak, M. R., Sapuan, S. M., Yidris, N., Fattahi, A. (2020). Experimental and numerical investigation of the mechanical behavior of full-scale wooden cross arm in the transmission towers in terms of load-deflection test. *Journal of Materials Research and Technology*, 9 (4), 7937–7946. doi: <https://doi.org/10.1016/j.jmrt.2020.04.069>
17. Salman, S., Sharaf, H. K., Hussein, A. F., Khalaf, N. J., Abbas, M. K., Aned, A. M. et. al. (2022). Optimization of raw material properties of natural starch by food glue based on dry heat method. *Food Science and Technology*, 42. doi: <https://doi.org/10.1590/fst.78121>
18. Raheemah, S. H., Fadheel, K. I., Hassan, Q. H., Aned, A. M., Turki Al-Taie, A. A., Sharaf, H. K. (2021). Numerical Analysis of the Crack Inspections Using Hybrid Approach for the Application the Circular Cantilever Rods. *Pertanika Journal of Science and Technology*, 29 (2). doi: <https://doi.org/10.47836/pjst.29.2.22>
19. Sharaf, H. K., Salman, S., Dindarloo, M. H., Kondrashchenko, V. I., Davidyants, A. A., Kuznetsov, S. V. (2021). The effects of the viscosity and density on the natural frequency of the cylindrical nanoshells conveying viscous fluid. *The European Physical Journal Plus*, 136 (1). doi: <https://doi.org/10.1140/epjp/s13360-020-01026-y>
20. Hussien, H. M., Yasin, S. M., Udzir, N. I., Ninggal, M. I. H., Salman, S. (2021). Blockchain technology in the healthcare industry: Trends and opportunities. *Journal of Industrial Information Integration*, 22, 100217. doi: <https://doi.org/10.1016/j.jii.2021.100217>
21. Abu Talib, A. R., Salman, S. (2022). Heat transfer and fluid flow analysis over the microscale backward-facing step using  $\beta\text{Ga}_2\text{O}_3$  nanoparticles. *Experimental Heat Transfer*, 1–18. doi: <https://doi.org/10.1080/08916152.2022.2039328>
22. Salman, S., Talib, A. R. A., Saadon, S., Sultan, M. T. H. (2020). Hybrid nanofluid flow and heat transfer over backward and forward steps: A review. *Powder Technology*, 363, 448–472. doi: <https://doi.org/10.1016/j.powtec.2019.12.038>
23. Sharaf, H. K., Ishak, M. R., Sapuan, S. M., Yidris, N. (2020). Conceptual design of the cross-arm for the application in the transmission towers by using TRIZ – morphological chart – ANP methods. *Journal of Materials Research and Technology*, 9 (4), 9182–9188. doi: <https://doi.org/10.1016/j.jmrt.2020.05.129>
24. Chauhan, P., Singh, A. K., Raghuvanshi, N. K. (2022). The state of art review on prosthetic feet and its significance to imitate the biomechanics of human ankle-foot. *Materials Today: Proceedings*. doi: <https://doi.org/10.1016/j.matpr.2022.03.379>