

The object of research is preprint processes for the manufacture of books with audio accompanying. The analytical and experimental studies reported here are based on the application of the methodology for devising a simulation model for calculating the complexity of preprint processes in the production of printed books with sound applications. The basic assumption of the study is that the use of simulation will contribute to the improvement of calculations of the complexity of preprint processes for making books with audio accompanying. This cannot be achieved without analyzing the factors influencing the convenience of perception of textual and sound information and establishing the objective function of mutual influence of the text of the publication and audio. A methodology has been proposed for calculating the complexity of the preprint process of making books with audio accompanying based on the developed algorithm of the technological process, mathematical representation of the structural model, as well as its components. It is shown that the process of creating audio accompaniment is affected by the content of printed pages, font design parameters, the selected format of page assembly, and the presence of illustrations. Based on the obtained expert assessments, a hierarchical representation of factors influencing the convenience of information perception is built; the interaction of parameters at different technological stages is described. The dependence of the complexity of the process of making books with audio accompanying on the volume of the book edition in the accounting and publishing sheets, the size and capacity of the font, as well as the speed of sound recording of the printed text, has been established. It is determined that with an increase in font capacity within 200...1000 thousand characters, the calculated labor intensity increases by 5 % to 20 %. The largest limits of changes in the complexity of creating an audio accompaniment are 9 %, at the stage of processing graphic information – 50 %

Keywords: simulation model, complexity of preprint process, audio accompaniment, font capacity, recording speed

UDC 655.3.066.11:004.032.6

DOI: 10.15587/1729-4061.2022.267797

CONSTRUCTION OF A SIMULATION MODEL FOR CALCULATING THE LABOR INTENSITY OF THE PRE-PRINT PROCESS OF MANUFACTURING BOOKS WITH AUDIO ACCOMPANYING

Tetiana Horova

Postgraduate Student

Department of Reprography*

Oleksandr Paliukh

Corresponding author

Doctor of Technical Sciences,

Professor, Head of Department

Department of Reprography*

E-mail: alekspalyuh@gmail.com

Yaroslav Zorenko

PhD, Associate Professor, Deputy Director*

Volodymir Oliinyk

PhD, Associate Professor

Department of Technology of Printing Production*

*Educational and Scientific Publishing

and Printing Institute

National Technical University

of Ukraine «Igor Sikorsky Kyiv Polytechnic Institute»

Peremohy ave., 37, Kyiv, Ukraine, 03056

Received date 26.08.2022

Accepted date 11.11.2022

Published date 30.12.2022

How to Cite: Horova, T., Paliukh, O., Zorenko, Y., Oliinyk, V. (2022). Construction of a simulation model for calculating the labor intensity of the pre-print process of manufacturing books with audio accompanying. *Eastern-European Journal of Enterprise Technologies*, 6 (1 (120)), 70–82. doi: <https://doi.org/10.15587/1729-4061.2022.267797>

1. Introduction

Most innovations introduced in the preparation and production of book publications are focused on the form of presentation of content and media, ensuring its high-quality and easy-to-use reproduction. The audio, video, graphic, and photo components of the integral publishing and printing block include additional tools that expand the functionality in using traditional book products. Interactive elements of augmented reality, developed and introduced into the publishing of books, given their significant impact on various human senses, contribute to the formation of additional benefits in the perception of information.

In addition, the property of a single book to be more attractive to readers compared to other publications that are similar in type and purpose is acquired only through the use of interactive elements of augmented reality. Interactive com-

plementary elements are manifested through tactile means of actuating audio, gif technologies, animation fragments, and video materials of various complexities. Interactive elements involved in individual species, or a structured sample, help expand the imagery close to virtual reality created by the human imagination in the process of reading the text.

Properly selected and actually applied sound design of the book effectively affects the imagination and perception of the reader, expands and enhances the memorization of thematic information, creates an additional sensual emotional background.

An book with audio accompanying makes it possible to divide familiarity with textual information into several components in a stochastic way separated in time. Under favorable conditions and convenient circumstances, familiarity with the text occurs in the usual way by reading the lines, activating sound or video effects that enhance the perception

of events, the description of which unfolds in the text. If it is necessary to interrupt reading when commuting to work, due to business, for sports, cooking, or other important actions that make the reading process situationally impossible, the audio accompaniment function is activated. The process of familiarizing yourself with the events or information provided in the book continues.

At the same time, the innovative embodiment of audio accompaniment into the structure of book publications in various creative manifestations requires additional acquisition of the traditional organizational structure of book publishing houses. First of all, sound designers, sound engineers, programmers with special skills, and software sound applications for creating an audio product. Audio accompaniment will maximally enhance the textual content with realistic surround sound design during the opening of each new page of the publication. In addition, special attention should be paid to the originality of sound effects, their apt use, and synergy with text images. Book publications with audio accompaniment are carriers of various types of content that require the use of new approaches to the technological processes of preprint.

An important criterion for the release of high-quality books with interactive applications is the process of assembling and editing the layout components of books with audio accompanying. The process of layout and editing, in terms of textual information, has certain features caused not only by the artistic selection of typefaces but by the size and scope of their application on each page. This is primarily due to the process of acting reading the text during audio recording. In addition, when changing the technological mode of the recording speed, the overall complexity of the process of creating books with audio accompanying can vary relatively widely.

The main stages of the technological process of manufacturing printed books with audio accompanying are characterized by different time expenditures and require publishers to carefully analyze the complexity of preprint processes. The purpose of this analysis is the systematization and structural combination of text and sound files and the optimization of publishing technologies. However, industry standards for the production of printed book products with interactive applications do not contain indicators of the complexity of preprint processes, with the help of which it is possible to optimize technological costs.

Therefore, it is a relevant task to study the features of editing layouts of publications with audio accompaniment, the main parameters of the technological process, the connections between them, and to devise a simulation model for calculating the complexity of the preprint process of making books with audio accompanying.

2. Literature review and problem statement

To maintain leading positions in technological and economic development, book publishing houses intensively introduce new communication and information technologies into book publications, which remain among the most desirable ways to obtain the necessary knowledge [1]. Therefore, the increase in the pace of innovation influence and the improvement of information resources contributes to the development of not only individual paper or electronic media but stimulates the infrastructural and complementary growth of each direction. First of all, in terms of preprint processes, which concerns the creation of layouts of future book publications with interactive applications.

Thus, in [2], the structural and functional model of information technologies for the formation of the quality of artistic and technical design of the book at the stage of preprint preparation is presented. The proposed technology makes it possible to build relationships between physically separated variables using tools and selected factors in the form of matrices for textual linguistic variables. However, it should be noted that in the cited paper there are no dimensional indicators of interaction factors. Based on the statistical data given in [3], the results of a survey of Danish experts in the publishing industry, a digital model, and a scheme for technological production of a book with audio are described. The dynamics between the economy and aesthetic quality of the process of choosing the saturation of sound are given. However, the benefits of the described digital model have not been confirmed by experimental studies. In the development of the results given in [3], the technology of TTS (Text-to-Speech) – mixing synthetic and recorded signals of natural speech – is investigated in [4]. The above technology contributes to the search and control of a compromise between the overall quality of the book with audio accompanying and the cost of its production. However, the characteristics of the recording quality of mixed signals and settings that affect the quality of the final sound recording are not sufficiently substantiated.

According to the authors of [5], some design elements that facilitate the perception of material in paper editions (for example, wide margins, large images) can complicate the use of interactive elements that complement textual explanations. However, the example of a textbook layout and layout creation does not show that the layout of a publication with text, images, and interactive elements should imply and take into account the added actions. In [6], the main stages of development of methods and tools for creating soundtrack for interactive applications with indicators of frequency sampling at the level of 44.1 kHz are considered. However, the specified value of the main characteristic of the sound is not justified and not comparable to other characteristics in terms of impact on the overall quality of the sound recording. In contrast to [6], the main motivation of work [7] is to implement a content research strategy, identify a possible amount of introduction and use of interactive elements that turn the reader into an active participant in the reading process. The limitations on the process of creating layouts for interactive workbooks are highlighted. However, the sequence of application of preprint tools, depending on the direction of the publication and the influence of the professional level of the programmers involved, is not taken into account.

The research reported in [8] considers technological development and features of distribution of printed, electronic, and audio books. It is noted that the world's leading publishing houses complement or duplicate traditional book publications by means of audio accompaniment. This factor plays an important role in finding complementary options for creating layouts of printed books involving interactive applications. However, there are no factors of mutual influence on the scope of application and layout of the audio accompaniment with the text part of the book.

In [9], a comparison of various technologies for creating books with audio accompanying is carried out, namely, the influence of sound effects and background music on the quality of information perception is determined. But the paper does not focus on the quality of perception of the phonogram when applying different sound recording technologies

for different types of printed books. However, the results of the above studies [9] are consistent with research [10] and significantly complement it. Important principles for designing the structure and book layout have been identified as they help encapsulate and disseminate research results, as well as create a cumulative body of knowledge. They are also of interest to design practitioners as they can provide synergistic recommendations for text, graphics, and sound content. However, there is no description of the recommended regulatory measures combining the volume of the text and sound components of the publication.

Development of recommendations for the use of audio accompaniment for a typical printed book to determine the time of creation of sound content is given in [11]. However, there are no recommendations for the ratio of sound content associated with the lines of text for which they were made. There are also no recommendations on the mechanism for adjusting the sound tempo, depending on the likely changes in the pace of reading the text. Therefore, the final calculation of the complexity of preparing the layout of the book, due to the involvement of a limited number of indicators, affects the importance of the results.

Study [12] shows that individual means of preprint preparation of layouts of books with audio accompanying are considered promising, subject to the technological application of digital printing. Digital printing provides limited lead time and situational change of image used for each individual print. It is shown that the factors of manifestation of the effectiveness of digital printing of book products are the possibility of combining a separate sound model of audio content with various options for thematic design of book layouts. In addition, book layouts can be personalized, for individual readers, through the addition of sound dedications, or other options for custom-made sound iterations. However, the expediency of using the listed technological capabilities is not confirmed by calculations of the complexity of preprint processes, which significantly affect the cost component of the publication with audio accompaniment.

Work [13] provides an analysis of the features of design and layout of interactive publications based on the study of the functional features of programs and content management systems used in publishing practices. It is noted that for publishers, the creation of interactive publications with a fixed layout is almost identical to the preparation of printed publications. In support of the results given in [13], the author of study [14] applied didactic modeling of the creation of book layouts, which takes into account favorable conditions for the use of multimedia applications. A comparative analysis of the capabilities of software applications, step-by-step technology, and design concept for creating layouts of books with interactive applications is carried out. However, as in [12], the rationality of structural proposals for the construction of books is not confirmed by calculations of the complexity of preprint processes.

Promising in terms of technological application are the means of modeling the processes of designing books using text descriptions, which are the interpretation of the elements of audio accompaniment [15]. Determining semantically the most significant factors of the information content of books and identifying an effective way to present these factors within the framework of the design of books shows the information specifics of the corresponding book. This greatly contributes to the accentuated thematic direction of creating audio content for the book. However, no algorithm for modeling the volume and sequence of application of factors of information content of books for audio accompaniment layout is revealed.

Our literary review shows that despite the practical significance of the research, the indicators of the complexity of preprint preparation of layouts of publications with audio accompaniment have not been sufficiently considered, calculated by input parameters and technological modes.

Therefore, there is reason to believe that the lack of appropriate determining ratios of the effectiveness of the technological system of preprint preparation of publications with audio accompaniment, which had been considered in a limited volume, necessitates research into this area.

3. The aim and objectives of the study

The aim of this work is to construct a simulation model for calculating the complexity of the preprint process of making books with audio accompanying. This will make it possible to improve the calculations of the complexity of the preprint process of making books of various formats, volumes, artistic and sound accompaniment.

To accomplish the aim, the following tasks have been set:

- to investigate the factors influencing the convenience of perception of textual and audio information;
- to construct a simulation model for calculating the complexity of the preprint process of creating books with audio accompanying;
- to conduct analytical studies of the complexity of the preprint process of creating books with audio accompanying by input parameters, technological modes, and complexity of production.

4. The study materials and methods

The object of our research is preprint processes for the manufacture of books with audio accompanying. The main hypothesis of the study assumes that the use of simulation will contribute to the improvement of calculations of the complexity of preprint processes when making books with audio accompanying. The conducted analytical and experimental studies are based on the application of the methodology for developing a simulation model for calculating the complexity of preprint processes while making books with audio accompanying. Problems of calculation results probability arise due to the lack of formalized indicators and factors of interaction of input parameters, technological modes, and complexity of production. Features of forecasting and minimization of indicators of production of books with audio accompanying, different in artistic and sound accompaniment, can be investigated and improved by simulation modeling of the calculation of the complexity of preprint processes.

An analytical review of technologies for creating book products with interactive applications and basic requirements for their characteristics was carried out. To carry out a systematic analysis of indicators and factors of interaction of input parameters, technological modes, and complexity of production, the market of book publications in Ukraine was investigated. In addition, the range of book products with audio accompaniment from well-known book publishing houses and Internet resources is analyzed [16–20]. The main characteristics and indicators of book publications with audio accompaniment, which are taken into account in the process of developing an algorithm for the general technological process of making books with audio accompanying, are investigated (Fig. 1).

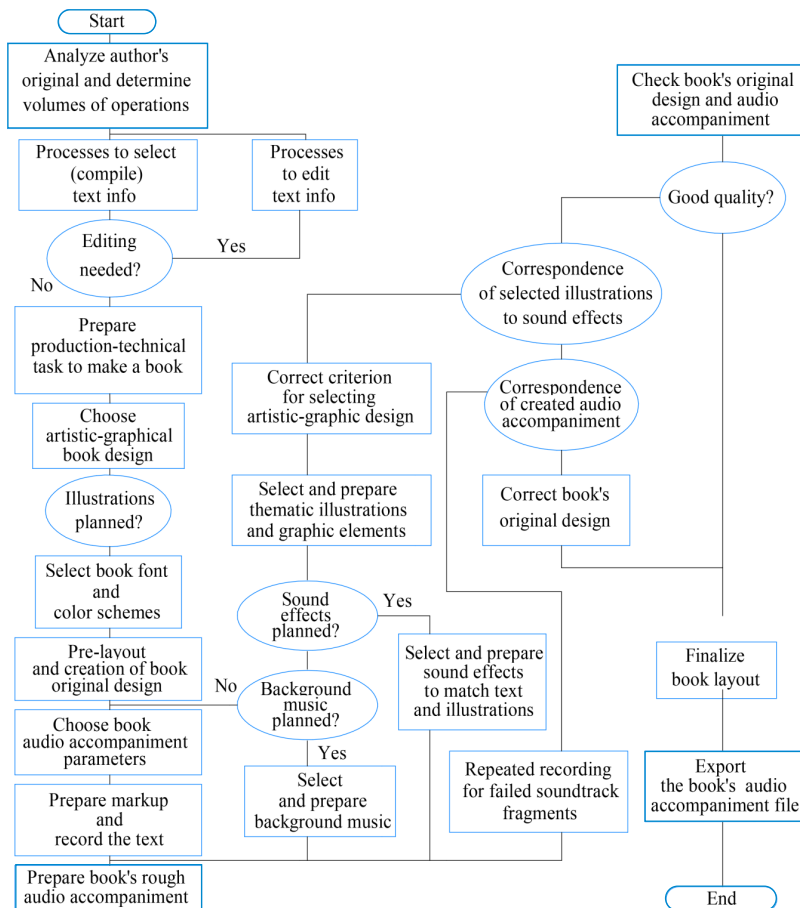

Fig. 1. Algorithm of the technological process of creating books with audio accompanying

nying accompaniment, for the general case, is represented by a mathematical structural model:

$$E = \Phi(y, x, a, \xi), \tag{1}$$

$$y = f(x, a, \xi), \tag{2}$$

where E is the result of the technological process, $x = (x_1, x_2, \dots, x_m)$ – vector of input variables (input information), $y = (y_1, y_2, \dots, y_n)$ – vector of the initial variables (controlled parameter), $a = (a_1, a_2, \dots, a_i)$ – vector of internal parameters of the system (technological modes), $\xi = (\xi_1, \xi_2, \dots, \xi_j)$ – vector of indefinite parameters (random factors).

To construct a simulation model for calculating the complexity of the preprint process, the Simulink module of the MATLAB R2016b software package (USA) was used to describe the interaction of parameters, modes, and factors operating at different technological stages.

The simulation model is based on data of rational time of sequential execution of operations of the technological process (Table 1). The construction of a simulation model involves the analysis and description of the functioning of subsystems of individual technological stages of production, and also determines the nature of the influence of various components on the complexity of the process.

According to the provisions of systems analysis, the technological process of making books with audio accompanying is schematically represented in the form of a system (Fig. 2), to the input of which information signals are given. Optimizing the test input helps find test cases that detect problems in the system. When choosing modes and methods of information processing, within the technological process, the links between its indicators and characteristics as functions of the optimization object are investigated [21].

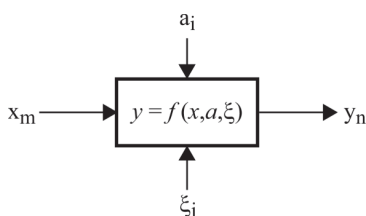

Fig. 2. Diagram of the model of the technological process of creating books with audio accompanying

The technological process of making books with audio accompa-

The list of variables in the technological process of creating books with audio accompanying

Table 1

No.	Variable	Essence of variable	Set of values
1	x_1	number of signs in the edition, signs	90,000–1,000,000
2	x_2	text complexity group	1–4
3	x_3	the number of sections	1–20
4	x_4	sheet format, sq	24–204
5	x_5	font point size, pt	8–14
6	x_6	illustrativeness, %	5–60
7	x_7	illustration complexity group	1–4
8	x_8	layout complexity group	1–4
9	x_9	sound effect difficulty group	1–3
10	x_{10}	the complexity of the audio accompaniment input process	1–2
11	y_1	time for assembly processes, hours	11–115
12	y_2	time for the development of a production and technical task, hours	1–71
13	y_3	graphic information processing time, hours	2–114
14	y_4	sound effects preparation time, hours	1–7
15	y_5	time to create audio accompaniment, hours	42–415
16	y_6	edition layout time, hours	10–252
17	y_7	layout preparation time, hours	1–2
18	y_8	time for quality control, hours	1–4
19	a_1	font capacity (average character width), mm	1.25–2.99
20	a_2	duration of the sound effect, s	5–20
21	a_3	sound recording speed, words/min	85–126
22	a_4	number of audio tracks	1–2
23	a_5	quality of audio information, Kbit/s	192–320
24	a_6	the number of controlled quality indicators	1–4
25	ξ_1	average number of text edits, pages	4–30
26	ξ_2	average number of sound recording takes	1–3
27	ξ_3	average volume of over-recorded audio accompaniment, h	0.2–4
28	ξ_4	the average amount of edition corrections	1–4

On the basis of the proposed algorithm of the technological process of creating books with audio accompanying (Fig. 1) and using a mathematical notation of the structural model (1), (2), the complexity of the individual stages is described:

$$y_i = f_i(x_j, a_k, \xi_m), \tag{3}$$

$$y_1 = x_1 \cdot x_2 \cdot x_3 \cdot \xi_1, \tag{4}$$

$$y_2 = x_1 \cdot x_4 \cdot x_5 \cdot x_6 \cdot a_1 \cdot a_2, \tag{5}$$

$$y_3 = x_4 \cdot x_7, \tag{6}$$

$$y_4 = x_4 \cdot x_8, \tag{7}$$

$$y_5 = a_2 \cdot x_9, \tag{8}$$

$$y_6 = a_3 \cdot a_4 \cdot a_5 \cdot \xi_2 \cdot \xi_3, \tag{9}$$

$$y_7 = x_{10} \cdot a_6, \tag{10}$$

$$y_8 = \xi_4, \tag{11}$$

$$E_{mp.} = \sum_{i=1}^n y_i, \tag{12}$$

where $E_{mp.}$ is the general complexity of the technological process of creating books with audio accompanying, hour; y_i – complexity of the i -th stage (f_i) of the technological process, h; x_j – parameters of input information (Table 1); a_k – technological modes (Table 1); ξ_m – random factors of the technological process (Table 1).

In other words, it is assumed that the complexity and overall complexity E_{mp} of the technological process of creating books with audio accompanying depends on a set of variable parameters, factors, and modes.

5. Results of research into the complexity of the preprint process of making books with audio accompanying

5.1. Studying factors that influence the convenience of perception of textual information

To analyze the most common range of book products with audio accompaniment, the software for recording and editing audio Adobe Audition (USA) was used. Adobe Audition has a comprehensive set of tools that includes support for work in reproducing the shape of the signal and its spectral reflection. The use of this application speeds up the processing of audio accompaniment, ensures constant sound quality in the process of creating, mixing, editing, and restoring audio content.

The parameters of sampling book products with audio were singled out and investigated, in particular, the output data of audio files distributed in MP3 format with a sample rate of 44.1 kHz, a bit rate of 128 kb/sec, or 320 kb/sec, a volume level of 17...19 dB.

In addition, it was established that the recording of audio accompaniment for books is possible in WAV format with

a sample rate of 48 kHz, a bit rate of 1536 kb/sec, a volume level of 21 dB. The speed of reproduction of textual information averages 105 words per minute. The peculiarities of the use of interactive applications for children’s literature, which differ from the use in other publications, fiction, educational, reference, audio accompaniment with a relatively slow mode of text reproduction, have been identified.

A book edition with audio accompaniment consists of a printed book and individual sound files with narration of text, music and background accompaniment. For easy reading and listening to the recorded interactive content, a page-by-page sound breakdown is carried out into separate files that are activated in proportion to the average speed of reading textual information.

Since the audio accompaniment is obtained by the addition of the printed book edition, the planning of its reproduction depends on the volume of the text, layout parameters, and the design of the original layout. That is, the capacity of the pages of the printed edition affects the process of creating audio, its sound saturation and intensity. In addition, the capacity of the printed page is affected by the font design parameters, the selected format of the folding page, the number and location of illustrations.

When creating an audio accompaniment of a book, it is necessary to take into account not only the technical characteristics of the paper book but also the index of perception of textual information. Such an index exists to determine the readability of the text. It can be calculated based on various parameters, for example, the length of words and sentences, the number of words often used, the number of complex words, etc.

To determine the factors influencing the convenient perception of information from the pages of book publications with audio accompaniment that meets the desires and expectations of consumers, a causal diagram of Ishikawa has been constructed (Fig. 3) [22]. Identification and analysis of causal relationships is the result of work within the tolerances established by the objective function of the mutual influence of the text part of the publication on the types and volumes of interactive audio applications.

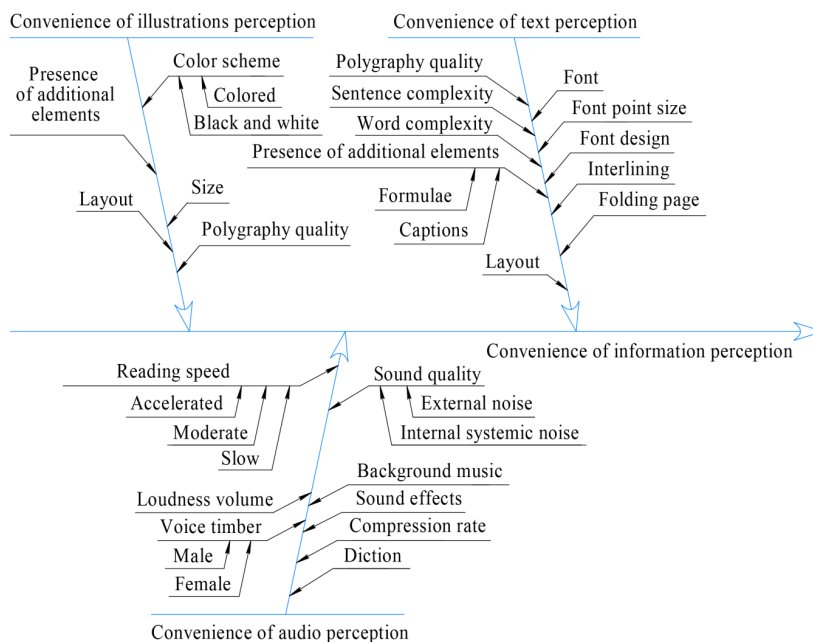

Fig. 3. Causal diagram of factors influencing the convenience of perception of information

To determine the expert assessment of the importance of the isolated elements, the method for paired comparisons was applied [23]. During the construction of matrices of paired comparisons, a scale of relations was used (Table 2) and the importance of criteria was assessed (Table 3).

Table 2

Scale of relations

Estimate	Significance of factors	Definition
1	Equal importance	The same effect
3	Weak (one factor prevails over another)	One factor is more important than the other
5	Substantial significance or strong	One factor has a certain advantage over the other
7	Very strong (obvious) significance	A significant advantage of one factor over another
9	Absolute significance	Absolute advantage
2, 4, 6, 8	Intermediate	Determining Importance Has trade-off value

Table 3

Evaluation of the importance of criteria

Criterion	RT	CR	SR	IP
RT	1	5	5	1/3
CR	1/5	1	3	1/3
SR	1/5	1/3	1	1/3
IP	3	3	3	1

After adding the rows of the matrix, the priority vector of the criteria matrix is obtained (11, 33, 4, 53, 1, 87; 10). After dividing each criterion by the sum of all elements of the vector (27.73), a normalized priority vector (0.40; 0.16; 0.06; 0.36) is obtained. In addition, the actual value of the matrix $\lambda_{max}=4.67$, the consistency index $CI=0.22$, and the consistency ratio $VU=0.25$. Hence, it turns out that the most significant criteria for users are the readability of the text, the integrity of the publication, the clarity of reading, and the speed of reading. After that, expert assessments of the importance of readability of the text were determined. Expert evaluation was carried out by specialists of book production at the State Publishing House «Press of Ukraine» and specialists of the recording department at the National Public Television and Radio Company «Ukraine». Using the method for paired comparisons, the following parameters were evaluated: folding page, font, size, layout, printing quality. During the formation of matrices of paired comparisons, a scale of relations was used (Table 2) and the importance of the criteria was assessed (Table 4).

Table 4

Assessing the importance of criteria

Criterion	FP	FT	CFS	L	PQ
FP	1	1/5	1/5	1/7	1/3
FT	5	1	1/5	3	1/3
CFS	5	5	1	3	3
L	7	1/3	1/3	1	3
PQ	3	3	1/3	1/3	1

After adding the rows of the matrix, the priority vector of the criteria matrix is obtained (1.54; 9.20; 14; 8.67; 6.67). After dividing each criterion by the sum of all elements of the vector (40.08), a normalized priority vector (0.03; 0.22; 0.34; 0.21; 0.16) is obtained. In addition, the actual value of the matrix $\lambda_{max}=6.39$, the consistency index $CI=0.34$, and the consistency ratio $VU=0.31$.

The sequence of the weightiest criteria for users consists of font size, font types, layout, folding pages, and printing. Based on the stated sequence, a hierarchical construction of elements of the influence of weighty criteria is presented (Fig. 4).

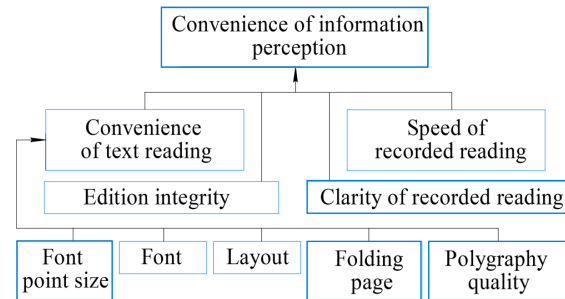

Fig. 4. Hierarchical construction of the presentation of factors influencing the convenience of perception of information

Based on the analysis and evaluation of factors of influence by the method for paired comparisons, a generalized formula has been derived to determine the readability of the text:

$$I_{cir} = 0.35K_{fpz} + 0.22K_{fc} + 0.21K_{cl} + 0.16K_{pa} + 0.36I_{ri} + 0.16K_{cr} + 0.06K_{sr}, \tag{13}$$

where I_{cir} is the complex indicator of readability, K_{fpz} – font point size, K_{fc} – font capacity, K_{cl} – complexity of layout, K_{pa} – printing accuracy of reproduction (delta), I_{ri} – readability index, K_{cr} – clarity of recorded reading, K_{sr} – speed of recorded reading.

The indicator «printing accuracy of reproduction» corresponds to the features of the applied type of printing, reproduction quality, quality, and types of paper. The readability index, in turn, is determined using the Flash formula [24]:

$$I_r = 206,835 - 1.015 \frac{\text{total words}}{\text{total sentences}} - 84.6 \frac{\text{total syllables}}{\text{total words}}. \tag{14}$$

5. 2. Construction of a simulation model for calculating the complexity of the preprint process of making books with audio accompanying

Based on the proposed structural model (1) to (12) and its components (Table 1), as well as the algorithm of the technological process of creating books with audio accompanying, a simulation model was constructed in the MATLAB Simulink software (Fig. 4). The proposed simulation model describes the influence of various factors of the technological process on the complexity of creating books with audio accompanying.

The principle of operation of the constructed simulation model (Fig. 5) is that the technological process of creating books with audio accompanying consists of eight subsystems (4) to (11), which include the main stages: the processes of preparing textual information (f_1), drawing up production

and technical specifications (f_2), processing graphic information (f_3), layout of the original layout of the publication (f_4), preparation of sound effects (f_5), creation of audio accompaniment (f_6), preparation of a book with audio accompaniment (f_7), and verification of the quality of the publication (f_8). Accordingly, the components of the model are fed

to the input of each subsystem (f_i) of the simulation model: input parameters (x_j), internal parameters (a_k), and indefinite parameters (ξ_m). The outputs of subsystems are a certain amount (complexity) of time spent (y_i) to perform each of the stages of the technological process of creating books with audio accompanying.

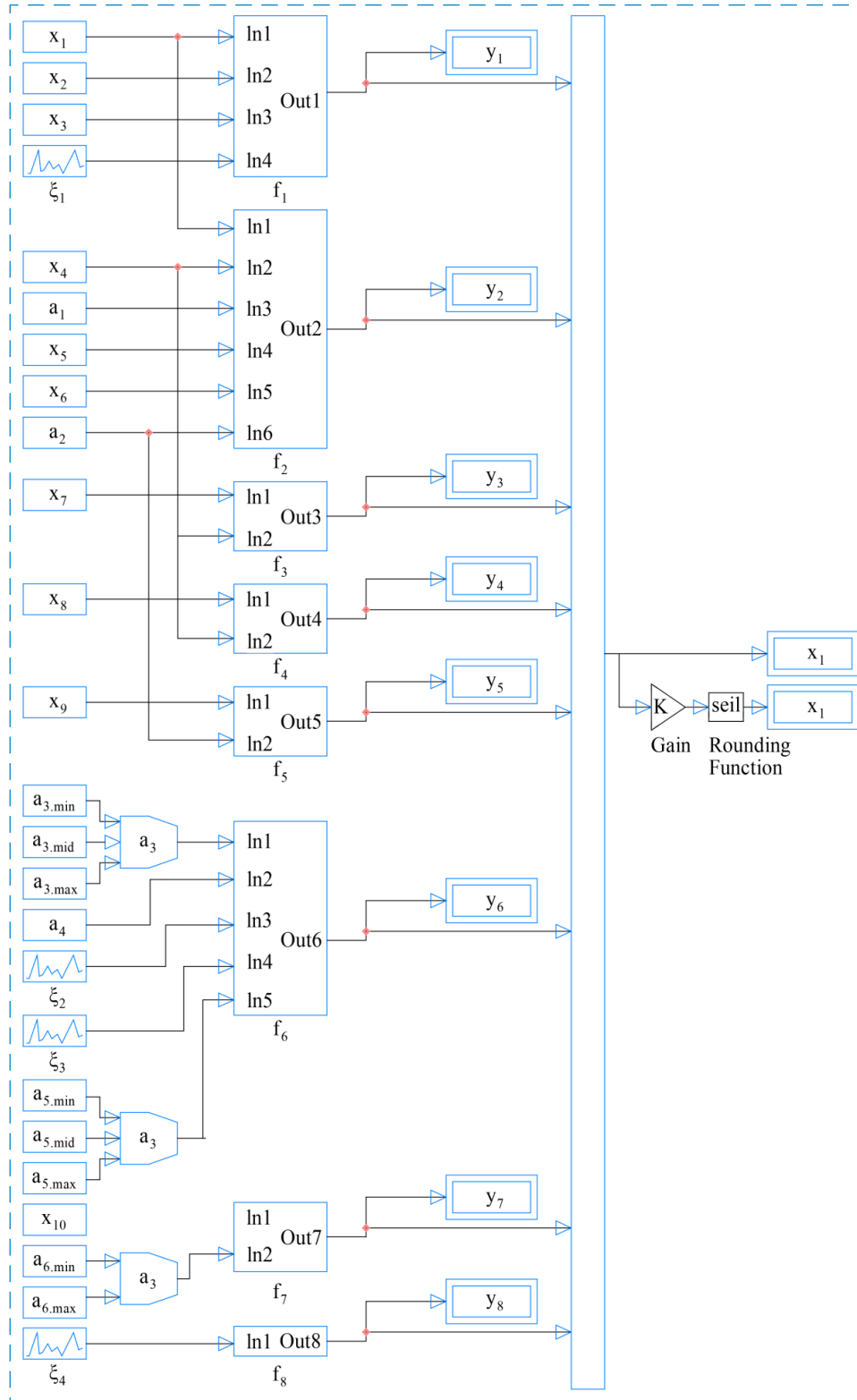

Fig. 5. Scheme of a simulation model for calculating the complexity of the technological process of creating books with audio accompanying

In the MATLAB Simulink software environment, the «Subsystem» blocks are used to mark subsystems (f_i), input (x_j) parameters – «Constant» and «Ramp», internal (a_k) parameters – «Constant» and «Variant Source» to create a simulation model, of undefined parameters (ξ_m) – «Uniform Random Number», initial parameters (y_i), respectively, «Display» blocks, etc. [25, 26].

The simulation model built is variable since it makes it possible to change the input data in a wide range (Table 1). For example, the input speed of sound recording (a_3) can be adjusted in three modes: slow, medium, and accelerated. These modes will ultimately affect the complexity of the technological process of creating a book with audio accompaniment. Therefore, with the help of this simulation model, it is possible to predict the intensity for publications of different characteristics and complexity of the production process.

5. 3. Analysis of the complexity of the preprint process by input parameters, technological modes, and complexity of production

According to the simulation model built, the technological process of making books with audio accompanying with different amounts of textual information $x_1=200...1000$ thousand characters was modeled. Moreover, for all other parameters of the model, standard values were applied: text complexity group $x_2=2$, the number of sections $x_3=10$, folding page format $x_4=6\cdot 10$ sq., font point size $x_5=10$ pts, illustrativeness $x_6=20\%$, complexity group of illustrations $x_7=3$, complexity group of layout $x_8=2$, complexity group of sound effects $x_9=2$, complexity of the audio accompaniment input process $x_{10}=2$, font capacity $a_1=1.76$ mm, duration of sound effect $a_2=20$ s, recording speed $a_3=105$ words/min, number of audio tracks $a_4=2$, and quality of audio information $a_3=256$ Kbit/s. All other parameters accepted random values (Table 1). According to the results of the simulation, a dependence plot was constructed, which determines the nature of change in the indicator of labor intensity. Below are the indicators of changes in the preprint process of making books with audio accompanying (E_h), depending on the volume of the book edition in the accounting and publishing sheets and the duration of audio accompaniment (Fig. 5).

When applied to the constructed simulation model (Fig. 5) of the standard parameters of the preprint process of making books with audio accompanying, there is a predicted linear relationship between the growth of the volume of the book edition and the complexity of its creation (Fig. 6). According to the simulation model, the estimated time for preprint processes is at least 210 hours, subject to the preparation of a book edition of an average volume of 10 accounting and publishing sheets and an audio accompaniment duration of 10 hours. It should be noted that the constructed simulation

model consists of eight consecutive technological operations of the preprint process of making books with audio accompanying. It is proved that the most time-consuming technological operations are the layout of the original layout of the publication (f_4) and the creation of audio accompaniment (f_6). In addition, we calculated labor intensity for a book of 200 thousand characters when changing the font point size (x_5), which is shown in Fig. 7.

According to the dependence plot of the complexity of the preprint process on the font point size (Fig. 6), an increase in the amount of labor intensity is observed with an increase in the font point size. Thus, with the same parameters of the technological process, changing the point size of the font from $x_5=8$ points to $x_5=12$ points leads to an increase in labor intensity by 15%. This is due to the increase in the volume of the book edition in pages since additional time is spent on the layout of additional pages and the creation of audio accompaniment.

Within the variability of the constructed simulation model, the influence of key technological modes on the complexity of the preprint process of creating books with audio accompanying is investigated. In particular, the influence of the selected size of the font capacity (Fig. 8) and the speed of sound recording of narration text (Fig. 9) on the amount of calculated labor intensity was determined.

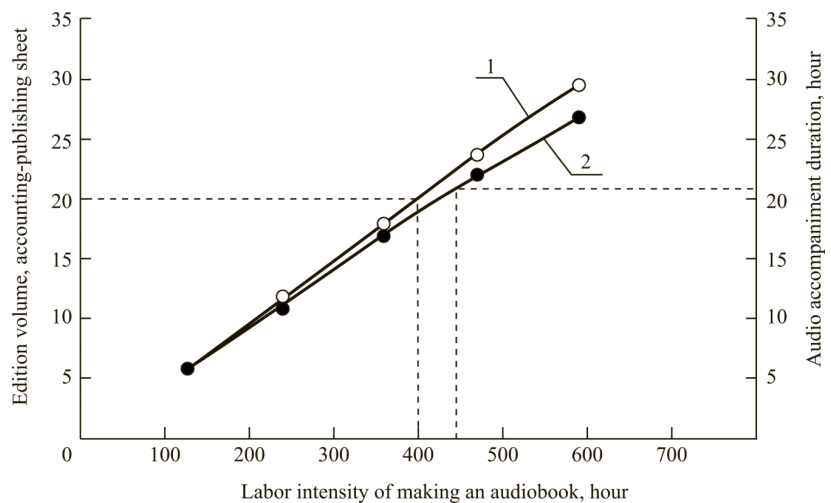

Fig. 6. Plot of the complexity of the process of creating books with audio accompanying (E_h) on the volume of the book edition in accounting-publishing sheets (1) and the duration of audio accompaniment (2)

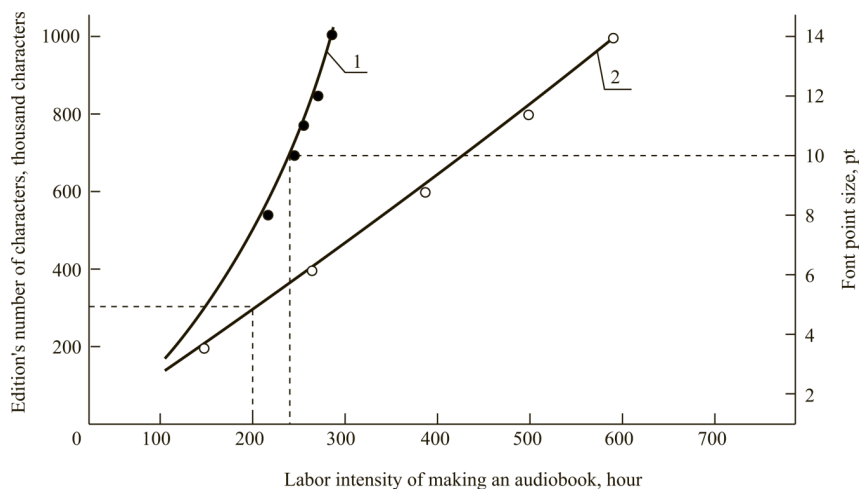

Fig. 7. Plot of the complexity of the process of creating books with audio accompanying (E_h) on font point size (1) and volume (2)

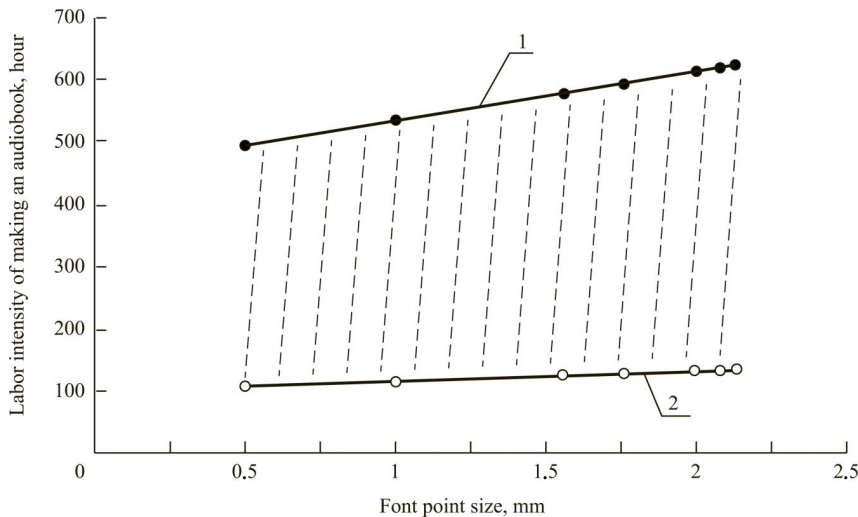

Fig. 8. Dependence plot of the complexity of the process of creating books with audio accompanying (E_h) on font capacity with an increase in the volume of a book edition, 1 – 200 thousand characters, 2 – 1000 thousand characters

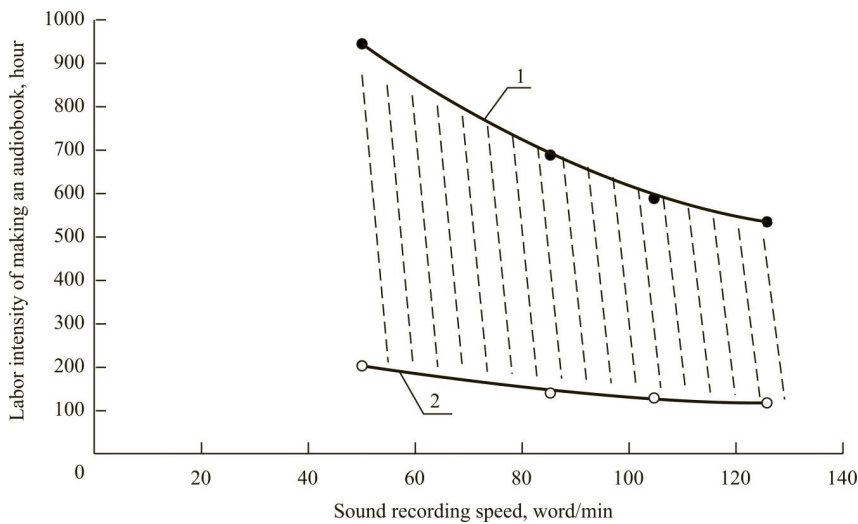

Fig. 9. Dependence plot of the complexity of the process of creating books with audio accompanying (E_h) on the speed of sound recording (a_2) with an increase in the volume of the book edition from 200 thousand characters (1) to 1000 thousand characters (2)

Thus, with an increase in font capacity, due to an increase in the volume of a book publication, from 200 thousand characters (1) up to 1000 thousand characters (2) (Fig. 8), the calculated complexity of the preprint process (E_h) increases. With a publication volume of up to 200 thousand characters, we observe an insignificant increase in labor intensity by 5%. However, with an increase in the volume of publication to 1000 thousand characters, labor intensity increases significantly by 20%. Therefore, there is reason to believe that for book publications with significant amounts of text, it is recommended to choose typefaces of fonts with moderate capacity.

The technological mode of changing the speed of sound recording (a_2) for the process of creating audio accompaniment for books (f_6) significantly affects the change in the total complexity of the preprint process (Fig. 7). Thus, when changing the speed of sound recording (a_2) in the standard range from 85 to 126 words/min, the complexity varies within 20%. At the same time, the change in the calculated amount of labor intensity due to a change in the speed of sound recording directly does not depend on the volume of the book edition in thousand characters. It should be noted that the increase in the recording speed (a_2) to 126 words/min reduces the complexity of the preprint process of creating books with audio accompanying to the specified 20%.

On the basis of the constructed simulation model, the complexity for each individual stage of the preprint process of creating a book with audio accompaniment (Fig. 10) is determined: preparation of textual information (f_1), preparation of production and technical specifications (f_2), processing of graphic information (f_3), layout of the original layout of the publication (f_4), preparation of sound effects (f_5), creation of audio accompaniment (f_6), preparation of a book with audio accompaniment (f_7), and quality control of the publication (f_8). It was established that the most time-consuming stage of preprint preparation is the creation of audio accompaniment (f_6), preparation of textual information (f_1), and layout of the original layout of the publication (f_4).

To determine the influence of the chosen complexity of the preprinting process of creating a book with audio accompaniment by parameters ($x_2, x_7, x_8, x_9, x_{10}$) and modes (a_4, a_5, a_6) to change the complexity we carried out calculation using a simulation model with the minimum and maximum values of the specified parameters $f_{i,min}$ and $f_{i,max}$ (Fig. 11).

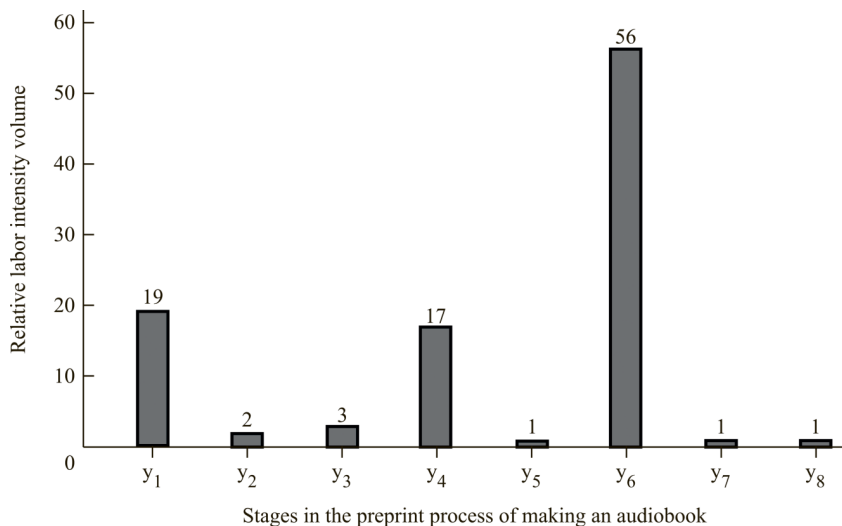

Fig. 10. The labor intensity of a typical preprint process of creating books with audio accompanying (E_h) in separate stages ($f_{i,mid}$)

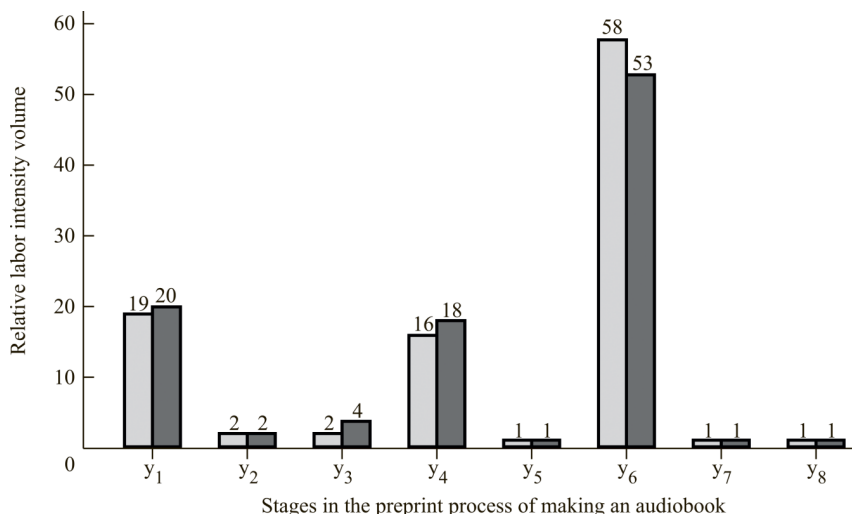

Fig. 11. The labor intensity of the preprint process of creating books with audio accompanying (E_n) in separate stages ($f_{i,\min}$, $f_{i,\max}$)

Changing the complexity of the preprint process leads to significant dimensional changes in the labor intensity of individual stages (Fig. 9). The difference between $f_{i,\min}$ and $f_{i,\max}$ concerns mainly the stage of preparation of textual information (f_1), processing of graphic information (f_3), the processes of layout of the original layout of the publication (f_4), and the creation of audio accompaniment (f_6). The magnifying limits of changes in the labor intensity of the stage of creating an audio accompaniment (f_1) are 9%, and the stage of processing graphic information (f_3) – 50%. The significant influence of the modes of complexity of the preprint process of each of these stages (Table 1) determines the total indicators of labor intensity and the possibility of its regulation and minimization.

6. Discussion of results of the construction of a simulation model for calculating the labor intensity of the preprint process of making books with audio accompanying

The results of our study of preprint processes for making books with audio accompanying have shown that the audio accompaniment is an interactive addition to the publication and depends on the layout and design of the original layout of the printed book. At the same time, the process of creating an audio accompaniment is influenced by the capacity of printed pages, font design parameters, the selected format of folding pages, and the presence of illustrations.

In addition, it was found that most books with audio accompanying are distributed in MP3 format, with a sample rate of 44.1 kHz, a bit rate of 128 kb/s or 320 kb/s, a volume level of $-17...-19$ dB. Accordingly, the optimal recording of audio for printed books is carried out in WAV format, with a sample rate of 48 kHz, a bit rate of 1536 kb/sec, a volume level of -21 dB. The identified dimensional indicators of the quality of sound recording and reproduction for further work with audio accompaniment are consistent with the research of the authors, carried out earlier [6, 7], and significantly complement them.

In addition, during the analysis, it became possible to determine the variable speed of the audio track of the printed book depending on the thematic purpose. For example,

the audio accompaniment of children's literature corresponds to the relatively slow reading of the text during the recording, compared to fiction and educational books. At the same time, for reference book publications and publications on business theory, the text is read at a more accelerated pace.

Based on the analysis of preprint technological processes for preparing layouts of book publications, an algorithm for the general technological process of making books with audio accompanying has been developed (Fig. 1). The purpose of the algorithm is to identify significant factors influencing the holistic perception of textual and audio accompanying information. As a result, a causal diagram of factors affecting the convenience of perception of information has been constructed (Fig. 3).

By indirectly assessing the influence of the factors given in the diagram, the main factors of convenience of perception of information are identified. These include readability of the text (font, point size, folding page); clarity and speed of reading; integrity of the publication (synergy of text, illustrations and audio accompaniment). Expert assessments of the importance of the identified factors by the method for paired comparisons were determined (Tables 2, 3). According to the results of the experiment, the most significant criteria are arranged in the following sequence: ease of reading the text, the integrity of the publication, clarity of reading, and speed of recording the text. According to the same method, expert assessments of the importance of the criterion of readability of the text were determined (Table 4).

It has been established that more weighty criteria for users are font size (point size), font types, layout, printing reproduction, and folding pages. On the basis of certain expert assessments, a hierarchical representation of factors influencing the convenience of perception of information is built (Fig. 4). In addition, a generalized formula for determining the readability of the text (13) was derived for calculating complex readability indicators when designing a publication.

According to the provisions of the systems analysis, the preprint process of creating books with audio accompanying is schematically represented in the form of a system (Fig. 2) to the input of which information signals are given. Signals that comprehensively affect the result of the technological process are conditionally divided in the following sequence:

- vector of input variables (input information – complexity group, number of characters in the publication, etc.);
- vector of output variables (controlled parameter – time, duration of technological operations);
- vector of internal parameters of the system (technological modes – sampling of sound recording quality settings);
- vector of indefinite parameters (random factors).

To construct a simulation model for calculating the labor intensity of the preprint process, the Simulink module of the MATLAB R2016b software package was used to describe the interaction of parameters, modes, and factors operating at different technological stages. The simulation model is based on data of rational time of sequential execution of operations of the technological process (Table 1). The development of a simulation model covers the analysis and

description of the functioning of subsystems of individual technological stages of production, and also determines the nature of the influence of various components on the complexity of the process.

This model is variable because it makes it possible to change the input data widely. For example, the input parameter of the recording speed (a_3) can be adjusted in three modes: slow, medium, accelerated. The variability of modes, as a result, affects the labor intensity of the entire technological process, which is consistent with the comparable results of technologies for creating books with audio accompanying of those given in work [9].

According to the constructed simulation model, we modeled the preprint technological process of creating books with audio accompanying with different amounts of textual information. Moreover, all other parameters of the model adhere to standard values. According to the simulation results, the dependence of the complexity of the process of creating books with audio accompanying was established:

- on the volume of the book edition in the accounting and publishing sheets and the duration of audio accompaniment (Fig. 5);
- on the font point size and its page-by-page arrangement (Fig. 6);
- on the capacity of the font with an increase in the volume of the book edition (Fig. 8);
- on the speed of sound recording of printed text (Fig. 9).

According to the plot of dependence of the labor intensity of the preprint process of creating layouts of books with audio accompanying on the font point size, there is an increase in the amount of labor intensity with an increase in the font point size. Thus, with the same parameters of the technological process, changing the size of the font from $x_5=8$ pt to $x_5=12$ pt leads to an increase in labor intensity by 15 %. This is due to the fact that increasing the font point size increases the volume of the publication and folding pages. In addition, the layout of additional pages of the assembly will require additional time.

It was investigated that with an increase in font capacity, the calculated labor intensity has a slight increase of up to 5 % with a publication volume of up to 200 thousand characters. However, with an increase in the volume of publication to 1000 thousand characters, labor intensity increases significantly by 20 %. Given this, it turns out that when working with large volumes of book publications with audio accompaniment, it is advisable to choose typefaces with moderate capacity.

In our research, the technological mode of changing the speed of sound recording and its influence on changing the overall complexity of the preprint process of creating books with audio accompanying were considered. Thus, when changing the speed of sound recording in the standard range from 85 to 126 words/min, the labor intensity changes within 20 %. Moreover, the change in the calculated value of labor intensity, in this case, does not depend on the volume of thousand characters for the selected book edition. It should be noted that the increase in recording speed to 126 words/min reduces the labor intensity of the preprint process of creating books with audio accompanying to the specified 20 %.

In addition, changes in the complexity of the preprint process lead to a change in the dimensional indicators of the labor intensity of individual stages. The difference between $f_{i,\min}$ and $f_{i,\max}$ concerns mainly the stage of preparation of textual information, processing of graphic information, layout of the original layout of the publication, and creation of audio accompaniment. This does not diverge from the

practical data given in works [13, 14] whose authors note the features of layout of interactive publications. However, unlike the results reported in [13, 14], it was established that at the stage of creating an audio accompaniment, it is possible to increase the dimensional indicators of changes in labor intensity by 9 %. In addition, at the stage of processing graphic information, it is possible to increase the dimensional indicators of changes in labor intensity by 50 %. The given dimensional indicators of changes in labor intensity are due to the significant influence of the complexity modes of these stages of the preprint process.

It should be noted that the use of modeling tools for preprint processes for the manufacture of printed books without sound applications is aimed only at observing the main components of the design of the publication. These components include the construction of the composition of the book edition, the dimensional proportionality of pages, covers, illustrations, as well as the harmony of the choice of font design and its combination with the theme of the book. In turn, the use of the methodology for creating books with audio accompanying as separate interactive objects also implies compliance with only complex indicators of textual sound recording without taking into account the design features of printed books. In our work, the main attention is paid to the construction of a synergistic method for calculating the labor intensity of preprint processes for the manufacture of printed books with audio accompanying. The difference between the developed methodology lies in the unifying systematization of complementary and mutually corrective elements of building layouts of printed books, taking into account the peculiarities of the accompanying sound recording.

Based on our analytical and experimental research, a simulation model for calculating the complexity of preprint processes has been built, which makes it possible to apply a reasonable approach to determining the factors of reproduction of books with audio accompanying. Features of the results obtained, from a practical point of view, are the use of structured parameters for calculating labor intensity. Technological changes in parameters and complementary relationships between them occur in accordance with the volume of the publication, font point size and font capacity, as well as the speed of the accompanying sound recording. This will make it possible to establish rational conditions for planning the labor intensity of preprint processes of various types of books with audio accompanying, based on their purpose.

Applicability of simulation modeling of the technological process of making books with audio accompanying with different amounts of textual information $x_1=200..1000$ thousand characters is limited by the standard values of other indicators. These values of text complexity indicators were $x_2=2$, the number of sections $x_3=10$, the format of the folding page $x_4=6\cdot10$ sq, the font point size $x_5=10$ pt, the illustrativeness $x_6=20$ %, the complexity of illustrations $x_7=3$, the layout $x_8=2$, sound effects $x_9=2$, font capacity $a_1=1.76$ mm, recording speed $a_3=105$ words/min.

The disadvantages of the applied procedure for calculating the labor intensity of the preprint process include the absence of some important criteria for the mutual influence of the dimensional indicators of the printed book and audio accompaniment, namely:

- the influence of sound recording as a result of the creation of an announcer phonogram and the ratio of the pace of narration of the text with the average reading rate of the printed text;
- the duration of the processes of recording and editing the audio accompaniment of printed books based on their purpose;

– dependence of page-by-page sound recording of the text on the complexity of the text and the qualifications of the announcer;

– features of assembly of sound files, fragments of rewriting, the duration of the process of adding accompanying sound effects to the narration and creating the final version of the audio accompaniment.

The main purpose of the simulation model is to improve the calculations of the labor intensity of the preprint process of making books of various formats, volumes, artistic and soundtrack. Therefore, further research will be aimed at identifying the influence of recording components on the overall complexity of the detailed process of preprint preparation of printed books with audio accompanying.

7. Conclusions

1. We have investigated factors influencing the convenience of perception of textual and sound information in the process of using printed books with audio accompanying. A distinctive feature of convenient reading and listening to recorded interactive content is a page-by-page sound breakdown into separate files that are activated in proportion to the average speed of reading textual information. In accordance with this, factors influencing the convenient perception of information as a result of identification and analysis of causal relationships are determined. The objective function of mutual influence of the text part of the publication on the types and volumes of interactive audio applications has been established. In addition, a hierarchical model of factors of influence is presented.

To determine the expert assessment of the importance of factors of influence, the method for paired comparisons was applied, a matrix of paired comparisons was formed, a scale of relations was used, and the importance of the criteria was assessed. After adding the rows of the matrix, the obtained priority vector of the criteria matrix is (11.33; 4.53; 1.87; 10). After dividing each criterion by the sum of all elements of the vector (27.73), a normalized priority vector (0.40; 0.16; 0.06; 0.36) is obtained. In addition, the actual value of the matrix $\lambda=4.67$, the consistency index $CI=0.22$, and the consistency ratio $VU=0.25$ are obtained. Based on our analysis and evaluation of factors of influence by the method for paired comparisons, a generalized formula was derived to determine the readability of the text.

2. A simulation model for calculating the complexity of the preprint process of making books with audio accompanying on the basis of the proposed algorithm of the technological process, the mathematical representation of the structural model and its components has been constructed. A distinctive feature of the model is that the technological process of making books with audio accompanying is divided into eight subsystems of the main stages. The ranking of subsystems was carried out sequentially from the preparation of textual information to the creation of sound effects and the final com-

positional file. Accordingly, the components of the model are fed to the input of each subsystem (f_i) of the simulation model: input parameters (x_j), internal parameters (a_k), and indefinite parameters (ξ_m). In addition, the outputs of subsystems are the outlined amount (labor intensity) of time spent (y_i) to perform each of the stages of the technological process of making books with audio accompanying. The constructed simulation model is variable since it makes it possible to change the input data within wide limits to calculate the labor intensity of preprint processes of publications of different characteristics.

3. Simulation was carried out on the basis of formalization of indicators of the labor intensity of the preprint process of making books with audio accompanying, which vary depending on the volume of text content of the printed book edition. According to the results of the simulation, a plot of changes in the indicators of labor intensity of the preprint process was constructed depending on the volume of the book edition in the accounting and publishing sheets and the duration of audio accompaniment.

The calculation of changes in labor intensity for a book of 200 thousand characters was carried out when changing the font point size. It is calculated that with the same parameters of the technological process, changing the size of the font point size from $x_5=8$ pt to $x_5=12$ pt leads to an increase in labor intensity by 15 %.

The influence of font capacity and speed of recording of narration text on the amount of calculated complexity is determined. With an increase in font capacity, due to an increase in the volume of the book edition from 200 thousand characters up to 1000 thousand characters, the calculated complexity of the preprint process increases by 5 % to 20 %.

Changes in the complexity of the preprint process, leading to a change in the labor intensity of individual stages, were investigated. The magnifying limits of changes in the labor intensity of the stage of creating an audio track (f_6) are 9 %, and the stage of processing graphic information (f_3) – 50 %.

Conflicts of interest

The authors declare that they have no conflicts of interest in relation to the current study, including financial, personal, authorship, or any other, that could affect the study and the results reported in this paper.

Financing

The study was conducted without financial support.

Data availability

The manuscript has no related data.

References

1. Tatarinova, L. (2020). Deiaki tendentsiyi rozvytku knyhodrukuvannia u providnykh krainakh svitu. Knyzhkova palata. Ukrainka asotsiatsiya vydavtsiv ta knyho rozpovsiudzhuvachiv. Available at: <http://www.upba.org.ua/index.php/uk/zakonodavstvo/knyzhkova-palata/item/121-deiaki-tendentsii>
2. Sichevska, O., Senkivskyy, V., Babichev, S., Khamula, O. (2019). Information Technology of Forming the Quality of Art and Technical Design of Books. Proceedings of the 1st International Workshop on Digital Content & Smart Multimedia (DCSMart 2019). Lviv. Available at: <http://ceur-ws.org/Vol-2533/invited5.pdf>

3. Have, I., Pedersen, B. S. (2019). The audiobook circuit in digital publishing: Voicing the silent revolution. *New Media & Society*, 22 (3), 409–428. doi: <https://doi.org/10.1177/1461444819863407>
4. Shamsi, M., Barbot, N., Lolive, D., Chevelu, J. (2020). Mixing Synthetic and Recorded Signals for Audio-Book Generation. *Lecture Notes in Computer Science*, 479–489. doi: https://doi.org/10.1007/978-3-030-60276-5_46
5. Nazarkevych, M. A., Storozh, O. V., Kliuinyk, I. I. (2015). Osoblyvosti rozroblennia interaktyvnykh elektronnykh knykh. *Visnyk Natsionalnoho universytetu «Lvivska politehnika». Seriya: Informatsiyni systemy ta merezhi*, 832, 332–347. Available at: <https://ena.lpnu.ua/items/bd1f653b-3a23-4278-a1d5-b8aee0fd37f0>
6. Zheliezniak, S. (2019). Specificity of audiovisual culture in multimedia space: sound aspect. *Culture and arts in the modern world*, 20, 238–248. doi: <https://doi.org/10.31866/2410-1915.20.2019.172449>
7. Sarasa-Cabezuelo, A. (2020). A Model for Creating Interactive eBooks for eLearning. *Future Internet*, 12 (12), 223. doi: <https://doi.org/10.3390/fi12120223>
8. Paper Books vs eBooks Statistics, Trends and Facts [2022]. Available at: <https://www.tonerbuzz.com/blog/paper-books-vs-ebooks-statistics/>
9. Steinhäusser, S. C., Schaper, P., Lugrin, B. (2021). Comparing a Robotic Storyteller versus Audio Book with Integration of Sound Effects and Background Music. *Companion of the 2021 ACM/IEEE International Conference on Human-Robot Interaction*. doi: <https://doi.org/10.1145/3434074.3447186>
10. Kruse, L. C., Puro, S., Seidel, S. (2022). How Designers Use Design Principles: Design Behaviors and Application Modes. *Journal of the Association for Information Systems*, 23 (5), 1235–1270. doi: <https://doi.org/10.17705/1jais.00759>
11. Morais, B. (2011). Books With Soundtracks: The Future of Reading? *The Atlantic*. Available at: <https://www.theatlantic.com/entertainment/archive/2011/08/books-with-soundtracks-the-future-of-reading/244344/>
12. Sharma, K. (2017). A review on role and benefits of digitalization in printing industry. *International Journal of Information Movement*, 2 (IV), 10–15. Available at: <http://www.ijim.in/wp-content/uploads/2017/08/Vol-2-Issue-IV-10-15-paper-2-Kanchan-Sharma-A-Review-on-Role-and-Benefits-of-Digitalization-in-Printing-Industry.pdf>
13. Zhenchenko, M. (2020). Technologies for the layout of interactive electronic editions. *Obriyi drukarstva*, 1 (8), 42–55. Available at: <https://www.researchgate.net/publication/338719964>
14. Kolesnyk, N. Ye. (2020). Web-dyzain multymedijnoi knyhy: teoriya i praktyka. *Zhytomyr: TOV «505»*, 180. Available at: http://eprints.zu.edu.ua/31340/1/web_2020.pdf
15. Durniak, B. V., Babynets, Ye. D. (2011). Sposoby rozshyrennia modeli vzaiemozviazku mizh parametry knyzhky ta spozhivacha informatsiynomy komponentamy. *Zbirnyk naukovykh prats Instytutu problem modeliuвання v enerhetytsi im. H. Ye. Pukhova NAN Ukrainy*, 59, 29–37. Available at: <http://dspace.nbuv.gov.ua/handle/123456789/28507>
16. Tismagambet, B. (2020). Effects of Audiobooks on EFL Learners' Reading Development: Focus on Fluency and Motivation. *English Teaching*, 75 (2), 41–67. doi: <https://doi.org/10.15858/engtea.75.2.202006.41>
17. Pobidash, I., Rozhanska, V., Figol, N. (2018). Market of online books in Ukraine. *Obriyi drukarstva*, 1 (6), 160–169. Available at: https://ela.kpi.ua/bitstream/123456789/34243/1/OD-2018-6_160-169.pdf
18. Khramova-Baranova, E. L., Sikora, Yu. A. (2017). Design of interactive children's books and its influence on the development of preschool education and culture in Ukraine. *Humanitarnyi visnyk*, 27 (11), 46–54. Available at: <https://er.chdtu.edu.ua/bitstream/ChSTU/1933/1/7.pdf>
19. Yefimova, M. P. (2015). Vydavnytstva dytiachoi knyhy v Ukraini: novitni vydavnychi tekhnolohiyi. *Teoriya ta praktyka dyzainu*, 7, 53–60.
20. Snelling, M. (2021). The Audiobook Market and Its Adaptation to Cultural Changes. *Publishing Research Quarterly*, 37 (4), 642–656. doi: <https://doi.org/10.1007/s12109-021-09838-1>
21. Boström, P., Björkqvist, J. (2012). Optimisation-based black-box testing of assertions in Simulink models. *TUCS Technical Report No 711*. Available at: <https://www.researchgate.net/publication/31595954>
22. Slobodan, S., Imre, K., Damjan, S., Nenad, J. (2014). Analysis of technological process of cutting logs using Ishikawa diagram. *Acta Technica Corviniensis – Bulletin of Engineering; Hunedoara*, 7 (4), 93–98. Available at: <https://www.proquest.com/docview/1618069477>
23. Kulchyt'ska, Kh. B., Predko, L. S. (2018). Zastosuvannia metodu analizu ierarkhiy pry vybori proektu v polihrafiyi. *Polihrafiya i vydavnycha sprava /Printing and publishing*, 1 (75), 51–59. Available at: <http://pvs.uad.lviv.ua/static/media/1-75/7.pdf>
24. Flesch, R. (1948). A new readability yardstick. *Journal of Applied Psychology*, 32 (3), 221–233. doi: <https://doi.org/10.1037/h0057532>
25. Hahn, B. H., Valentine, D. T. (2017). *Essential MATLAB for Engineers and Scientists*. Academic Press. doi: <https://doi.org/10.1016/c2015-0-02182-7>
26. Giannakopoulos, T., Pikrakis, A. (2014). *Introduction to Audio Analysis: A MATLAB® Approach*. Academic Press. doi: <https://doi.org/10.1016/C2012-0-03524-7>