

This paper considers the task to clarify the circumstances of a traffic accident (TA) involving two vehicles as a result of their lateral tangential collision at low angles.

The aim of the study is to construct a mathematical model of a tangential collision of vehicles for the reconstruction of TA circumstances.

Owing to the combination of the law of conservation of momentum and the theory of impact using the coefficient of recovery, it was possible to construct a mathematical model that describes the development of such an accident and makes it possible to determine the main parameters of the movement of vehicles after and before the collision. An answer is given regarding the possibility of losing the directional stability of the vehicle and its movement in the lateral direction because of a collision.

Based on the mathematical model, the basic parameters of vehicles motion after their side collision at angles of 5–15° were analytically determined, when there are no slip marks on the road surface.

A numerical experiment was conducted on the example of a specific accident. The findings make it possible to argue about the possibility of losing the directional stability of vehicles and shifting them to the oncoming lane or curb as a result of collision.

A comparison of the results of the numerical calculation with the results of software modeling of accidents and the circumstances that were established in the process of studying a real accident was carried out. It was concluded that the results obtained are consistent and make it possible to more accurately assess the parameters of the movement of vehicles after their lateral tangential collision. In general, this produces more objective results of the reconstruction of TA mechanism in cases where there are no traces of slipping and braking on the road surface.

The proposed mathematical model could be used in collisions accompanied by minor deformations or damage to vehicles

Keywords: vehicle, side impact, loss of stability, absence of braking, reconstruction of TA circumstances

UDC 656.08

DOI: 10.15587/1729-4061.2022.267800

CONSTRUCTION OF A MATHEMATICAL MODEL OF VEHICLES TANGENT COLLISION DURING RECONSTRUCTION OF THE CIRCUMSTANCES OF A ROAD ACCIDENT

Oleksii Saraiev

Doctor of Technical Sciences, Professor, Dean**

Alexey Voropay

Doctor of Technical Sciences, Professor,
Head of Department*

Oleksandr Koriak

PhD, Associate Professor*

Serhii Povaliaiev

Corresponding author

PhD, Associate Professor*

E-mail: povalyaevsi@ukr.net

Andrey Sharapata

PhD, Associate Professor*

*Department of Machine Components
and Theory of Machines and Mechanisms**

**Kharkiv National Automobile and Highway University
Yaroslava Mudroho str., 25, Kharkiv, Ukraine, 61002

Received date 02.09.2022

Accepted date 10.11.2022

Published date 30.12.2022

How to Cite: Saraiev, O., Voropay, A., Koriak, O., Povaliaiev, S., Sharapata, A. (2022). Construction of a mathematical model of vehicles tangent collision during reconstruction of the circumstances of a road accident. *Eastern-European Journal of Enterprise Technologies*, 6 (3 (120)), 44–50. doi: <https://doi.org/10.15587/1729-4061.2022.267800>

1. Introduction

A significant part of accidents, about 20 %, is associated with violations of the rules of maneuvering. Modern highways, as a rule, have several lanes for traffic in each direction. When driving on a road with several lanes, drivers, as a result of violation of the rules of maneuvering, can face a collision on the tangent, that is, the side surfaces of cars at a slight angle of 5–15°. Such a tangential (lateral) collision for one of the drivers is unexpected and he can apply braking only some time after the collision. As a result, at first glance, a slight side collision of two cars, Moving in adjacent lanes can lead to a loss of directional stability with exit to the oncoming lane. This can cause a secondary but already more dangerous frontal collision. Thus, a slight initial collision of two cars on a tangent can cause an accident with serious consequences.

The complexity of the reconstruction of such accidents determines the relevance of devising a methodology for assessing the parameters of the movement of vehicles after

the loss of their directional stability due to a side collision. Evaluation of motion parameters should include:

- determining vehicle speeds immediately before and after the collision;
- determining the angles of rejection and lateral movements to which the displacement of vehicles occurred after the collision;
- determining the time intervals and distance of vehicles after a collision, etc.

All this makes the methodology for the study of lateral tangential collisions an ambiguous task for experts. It needs to clarify important issues that are associated with the assessment of the parameters of the movement of cars in the absence of traces of braking and sliding on the road.

2. Literature review and problem statement

The task to determine the speed and other parameters of vehicle traffic in the reconstruction of the circumstances

of an accident that occurred as a result of a lateral collision (cross- or oblique impact) is not new and was covered in authoritative studies [1, 2].

Modeling of such accidents, as a rule, is carried out on the basis of the law of conservation of energy if it is possible to calculate the amount of deformation of vehicles due to their collision [3, 4]. However, transport collisions are not always accompanied by plastic deformations that can be measured. The use of elements of the theory of impact together with the law of conservation of energy makes it possible to extend the scope of its use in the study of the circumstances of an accident [5]. The law of conservation of momentum can also be used if it is possible to establish the speed of vehicles immediately before and after the collision [6, 7]. However, the traditional use of the law of conservation of momentum is based on the presence of a braking distance, which for certain reasons may be absent. Pulse models are widely used in software products using the finite-element method [8].

However, especially relevant are the tasks associated with the reconstruction of the circumstances of an accident. The difficulties of mathematical solution to such problems are associated with the need to solve the so-called inverse problems. Mathematical difficulties are usually solved by simplifying mathematical models. Thus, in [9], to simplify the mathematical problem of modeling an accident, a two-dimensional mathematical model was used.

The purpose of solving inverse problems is to determine the so-called initial conditions, and the initial data are various consequences of an accident. For example, in works [10, 11] an algorithm for identifying the initial conditions of impact of vehicles based on the analysis of structural deformations has been developed and implemented. However, the properties of inverse problems include uncertainty and instability of the results obtained, which has not been investigated. This problem is considered in [12, 13]. They pay considerable attention to the analysis of the uncertainty of the results obtained and the reliability of the reconstruction of accidents when identifying the speed of vehicles.

The problem of predicting the possibility of tipping vehicles is considered in papers [14, 15]. A rollover prediction algorithm for use on vehicles with high lateral speed and a high center of gravity is presented. By calculating the ratio of lateral energy reserves in real time and the rollover threshold, the degree of risk of tipping is determined. Study [16] reported and confirmed experimentally the original method of predicting the risk of overturning heavy vehicles. It is based on the calculation of the transmission coefficient load, which depends on the estimated vertical forces.

Significant problems in the reconstruction of the circumstances of an accident arise in the absence of traces of braking on the road surface. Such cases are especially characteristic of accidents involving cars equipped with an anti-lock braking system. Features of the reconstruction of the circumstances of such accidents are considered in [17, 18].

However, the absence of braking marks on the road surface can also be observed in case of cross-collision of vehicles. In a collision of vehicles moving in the same direction, at low angles, the driver's reaction may be too late to brake. A feature of cross-collisions is that after a collision, there may be a loss of stability and slipping of vehicles. Traces of slipping and braking (S_1 , S_2) on the road surface, as well as the final location of the cars, allow the expert to draw up an accident scheme (Fig. 1) [1].

This makes it possible to determine the trajectory, angles of reclining (ϕ_1 , ϕ_2), angles of rotation (ε_1 , ε_2), the distance of movement (S'_1 , S'_2), and the speed of both vehicles after the collision. At the same time, it is assumed that the kinetic energy of gradual and rotational motion (around the center of mass) of vehicles goes into work with tire friction.

However, not always after a cross-collision there are traces of slipping and braking. This is especially true of lateral tangential collisions in passing directions of movement at small angles of 5–12°. After that, the vehicle, as a result of collision and loss of directional stability of movement, can change the trajectory of movement and go into the oncoming lane or curb. The absence of braking before a lateral tangent collision and some time after it makes it impossible to calculate the parameters of vehicle traffic according to well-known expert methods.

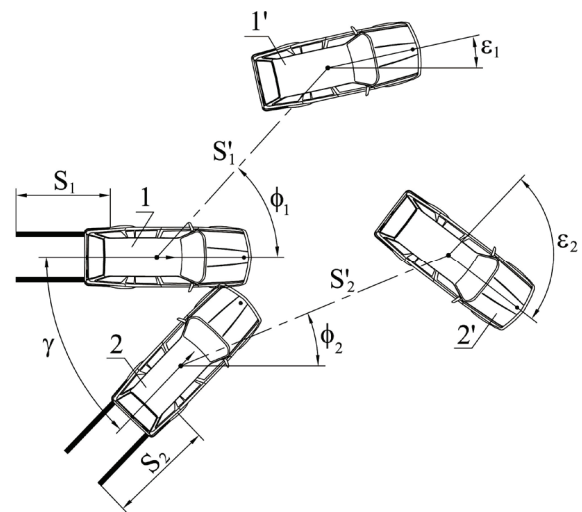

Fig. 1. Vehicle collision pattern

All this suggests that conducting a study on the reconstruction of an accident in a lateral tangential collision of vehicles at low angles is appropriate.

3. The aim and objectives of the study

The aim of this study is to construct a mathematical model of a tangential collision of vehicles to determine the basic parameters of the movement of vehicles after and before a collision, as well as to predict the possibility of loss of stability of vehicles as a result of collision.

To accomplish the aim, the following tasks have been set:

- to build a mathematical model to determine the possibility of losing the directional stability of the vehicle and its movement in the lateral direction;
- to build a mathematical model to determine the basic parameters of vehicle traffic due to a lateral tangent collision at low angles;
- to simulate the mechanism of lateral tangential collision of vehicles at low angles.

4. The study materials and methods

The object of our study is a traffic accident of two vehicles as a result of their lateral tangential collision at slight angles.

When examining such cross-collisions, the law of conservation of momentum is usually used. However, when there are no traces of slipping and braking, its use is complicated.

It is proposed in the study of these types of accidents to supplement the use of the law of conservation of momentum with elements of the theory of impact.

To determine the possibility of loss of directional stability of the vehicle and its movement in the lateral direction, the equilibrium equation is used. The friction force acting in the contact patch of the wheels in the lateral direction is compared with the impact force. To determine the impact force, a mathematical model is proposed based on the application of the law of conservation of momentum and the theory of impact using the restoration coefficient.

To determine the magnitude of the movement of a vehicle in the lateral direction in case of loss of its directional stability and the time during which this movement occurred, the theorem for the conservation of kinetic energy is used.

On the basis of the constructed mathematical model, the main parameters of the movement of vehicles after their lateral tangential collision at angles of 5–15° are analytically determined.

To assess the reliability of the results, a specific accident was modeled in the Cybid V-SIM version 3.0.35 software (Poland). The numerical results of software simulation are compared with the numerical results of mathematical modeling obtained in this study.

5. Results of modeling a tangential collision of vehicles in the reconstruction of the circumstances of a traffic accident

5.1. Construction of a mathematical model for determining the possibility of losing directional stability of a vehicle

The case of a lateral tangential collision of vehicles moving in the opposite direction is considered (Fig. 2). The vehicle at number 1 (V 1) moves directly along the lane. As a result of violation of the rules of maneuvering, the vehicle at number 2 (V 2) makes a side collision with the front of vehicle 1 at a slight angle of contact $\gamma=5-15^\circ$. There are no slip marks on the road surface. The angles of rejection of V 2 and V 1 (angle ψ), as well as the parameters of movement of vehicles after a collision are not possible to determine by expert methods.

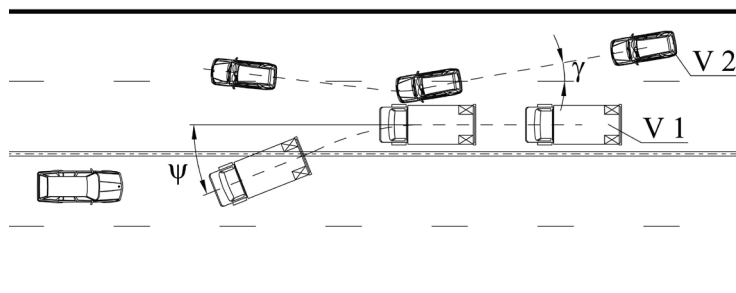

Fig. 2. Scheme of tangential collision with the side surfaces of vehicles with subsequent exit to the oncoming lane

For the loss of directional stability of the movement of V 1 with its displacement in the lateral direction, the condition must be met [1, 6]:

$$F_{\text{imp}} > F_{\text{frict}}, \tag{1}$$

where F_{imp} is the projection of the impact force of V 2 against V 1 on an axis perpendicular to the direction of movement; F_{frict} is a friction force acting in the contact patch of the wheels of V 1 in the lateral direction.

In determining the friction force, some assumptions have been made: since no braking occurred at the time of the collision, the coefficient of friction in the lateral direction is $\phi_Y=\phi$; since there was a collision of the front left part of V 2 with the right front of V 1, the friction force of only the front axle of V 1 is taken into account. Then the friction force is equal to

$$F_{\text{frict}} = m_1 \cdot g \cdot \phi_Y, \tag{2}$$

where m_1 is the mass of the front axle of V 1, $g=9.81 \text{ m/s}^2$.

The projection of the impact force F_{imp} V 2 against V 1 on an axis perpendicular to the direction of movement was found through a shock pulse:

$$F_{\text{imp}} \cdot \Delta t = m_1 \cdot (U_1 - V_1) \Rightarrow F_{\text{imp}} = \frac{m_1 \cdot (U_1 - V_1)}{\Delta t}, \tag{3}$$

where m_1 – mass of V 1; U_1 and V_1 – the speed of V 1 in the lateral direction, respectively, after and before the impact ($V_1=0 \text{ m/s}$); Δt – the duration of impact in a collision of vehicles; it is within 0.07...0.14 s [1, 7].

To determine U_1 , the recovery coefficient after impact was used [1, 7]

$$K_{\text{imp}} = \frac{U_2 - U_1}{V_1 - V_2}, \tag{4}$$

where U_2 and V_2 are the speed of V 2 in the lateral direction, respectively, after and before the impact.

According to the recommendations from [1, 7], at a relative speed of $\Delta V < 8.3 \text{ m/s}$, K_{imp} is 0.7.

$$V_2 = \frac{V_2'}{3.6} \cdot \sin(\gamma), \tag{5}$$

where V_2' is the full speed of V 2; γ – the angle at which the collision occurred, in degrees.

The following is the recorded projection of the law of conservation of pulses on the axis, which is perpendicular to the direction of movement of V 1:

$$m_2 \cdot V_2 = m_1 \cdot U_1 + m_2 \cdot U_2, \tag{6}$$

where m_2 is the mass of V 2.

Based on the expression (4), we obtained

$$m_2 \cdot V_2 = m_1 \cdot U_1 + m_2 \cdot K_{\text{imp}} \cdot (V_1 - V_2) + m_2 \cdot U_1 \Rightarrow U_1 = \frac{m_2 \cdot V_2 \cdot (1 + K_{\text{imp}})}{m_1 + m_2}. \tag{7}$$

In numerical calculations, a case of a specific accident was considered, where V 1 was a Mercedes 814 car, and V 2 was a VAZ-21214 car. V 1 moved in a straight line at a distance of 0.4 meters from road markings No. 1.3. Vehicle 1 speed is $V_1' = 40 \text{ km/h}$. Workload – driver and cargo in a van weighing 300 kg. V 2 moved in a straight line at a distance of 2.1 meters to the right edge of the roadway. Vehicle 2 speed is $V_2' = 60 \text{ km/h}$.

After changing its movement on the left, vehicle 2 went to the left lane of the passing direction of movement where there was a collision of the front left part of V 2 with the right front of V 1. The workload was the driver and three passengers. At the time of the initial contact of V 2 and V 1, their longitudinal axes were at an angle of $\gamma=10\pm5^\circ$ and there was a passing, sliding collision. The road profile is horizontal, the type of road surface is asphalt concrete, the condition of the road surface is wet, clean. The total weight of V 1 is 7375 kg, V 2 – 1510 kg.

The results of calculating the impact force compared to the friction force are shown in Fig. 3.

As can be seen from Fig. 3, only at $\gamma=5^\circ$, provided that the duration of the impact Δt is greater than 0.13 s, the impact force is less than the friction force and the movement of V 1 in the lateral direction does not occur. In all other cases, there is an excess of the impact force over the friction force, which means the loss of directional stability of V 1 and its movement in the lateral direction.

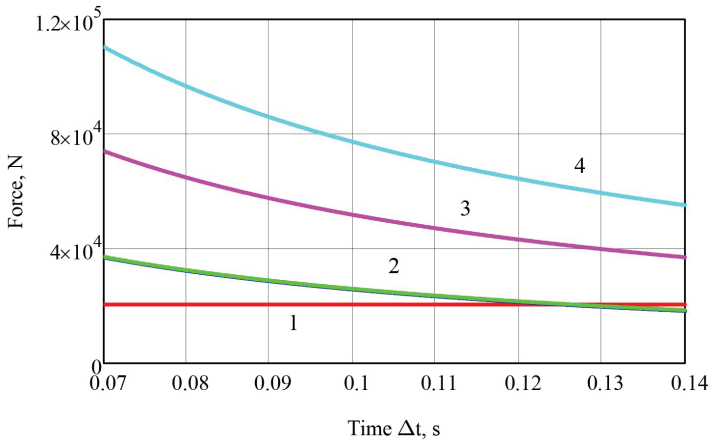

Fig. 3. Impact force compared to friction force in a lateral tangential collision of vehicles: 1 – friction force; 2 – impact force at $\gamma=5^\circ$; 3 – impact force at $\gamma=10^\circ$; 4 – impact force at $\gamma=15^\circ$

5.2. Construction of a mathematical model for determining the parameters of vehicle movement due to a tangential collision

To determine the magnitude of the movement of V 1 in the lateral direction in the case of loss of its exchange rate stability, the theorem for the conservation of kinetic energy is applied [1]

$$\frac{m_1 \cdot U_1^2}{2} - \frac{m_1 \cdot U_{10}^2}{2} = F_{\text{frict}} \cdot S, \quad (8)$$

where $U_{10}=0$ is the final speed of V 1 in the lateral direction; S is the lateral movement of V 1 after impact.

The value of the lateral movement of V 1 after impact in the case of loss of directional stability of movement was obtained

$$S = \frac{m_1 \cdot U_1^2}{2 \cdot F_{\text{frict}}} = \frac{m_1 \cdot U_1^2}{2 \cdot m_1 \cdot g \cdot \phi_Y} = \frac{U_1^2}{2 \cdot g \cdot \phi_Y}. \quad (9)$$

The results of the calculation are shown in Fig. 4.

These calculations show that the value of the lateral movement of V 1 due to the impact and loss of stability ranged from 0.047 m at $\gamma=5^\circ$ to 0.415 m at $\gamma=15^\circ$. That is, V 1 after the collision was within its lane.

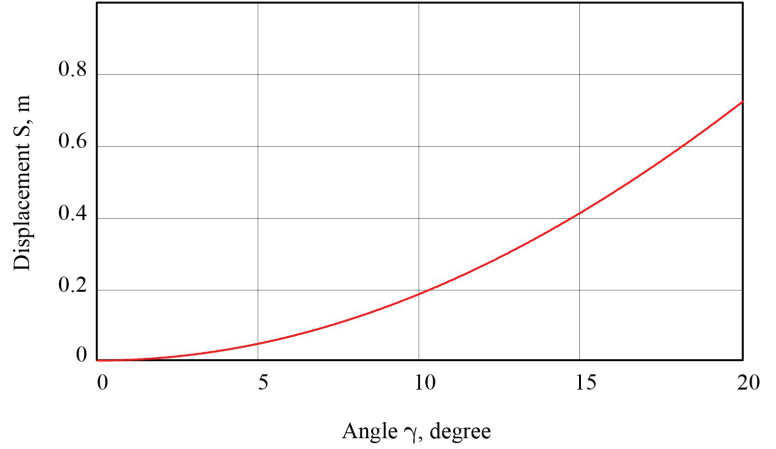

Fig. 4. The value of the lateral movement of V 1 due to impact

The time during which the lateral movement of V 1 occurs after impact and loss of stability of movement

$$t = \sqrt{\frac{2 \cdot S}{a}}, \quad (10)$$

where a is the acceleration of V 1 in the lateral direction resulting from impact,

$$a = (F_{\text{imp}} - F_{\text{frict}}) / m_1. \quad (11)$$

The distance that V 1 traveled during the lateral movement in the direction of its gradual movement, provided that there is no braking

$$S' = V_1' \cdot t. \quad (12)$$

In a lateral collision of vehicles with small angles of contact, it can be assumed that the movement S' occurred along a rectilinear trajectory. Then the angle of rejection of V 1 from the previous direction of movement in degrees can be found as follows

$$\psi = \frac{180}{\pi} \cdot \arcsin\left(\frac{S}{S'}\right). \quad (13)$$

The results of the calculation of the angles of rejection of V 1 after the collision are shown in Fig. 5.

The time of movement of V 1 in the lateral direction to the boundary of the oncoming lane is

$$t = \frac{x}{V_1' \cdot \sin(\psi)}, \quad (14)$$

where x is the distance from V 1 to the boundary of the oncoming lane.

The results of the calculation of the time required for the exit of V 1 after a collision into the oncoming lane are shown in Fig. 6. At the value of the angles of rejection of V 1 close to 7–10°, the time of departure of V 1 into the oncoming lane is 0.65...1 s. This is equal to the reaction time of the driver, so the driver of V 1 could not use braking to prevent entry into the oncoming lane. At the value of the angle of rejection of V 1 close to 4–6°, the time of departure of V 1 into the oncoming lane is 1...1.5 s. This is almost equal to the sum of the driver's reaction time and

the response time of the car's brakes. Therefore, the driver of V 1, in this case as well, could not avoid leaving the lane boundary by applying braking.

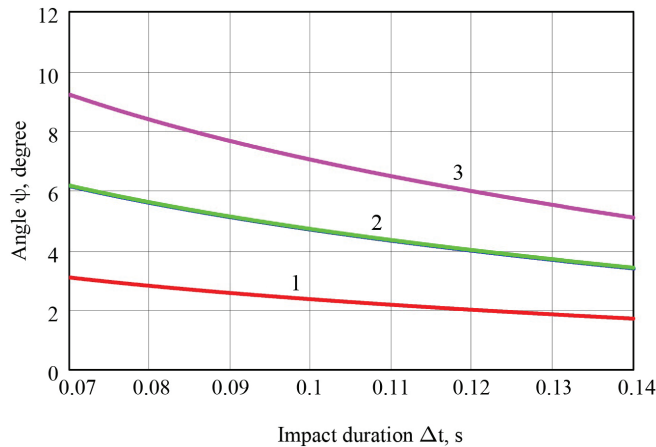

Fig. 5. Vehicle rejection angle 1: 1 – angle of contact $\gamma=5^\circ$, 2 – $\gamma=10^\circ$, 3 – $\gamma=15^\circ$

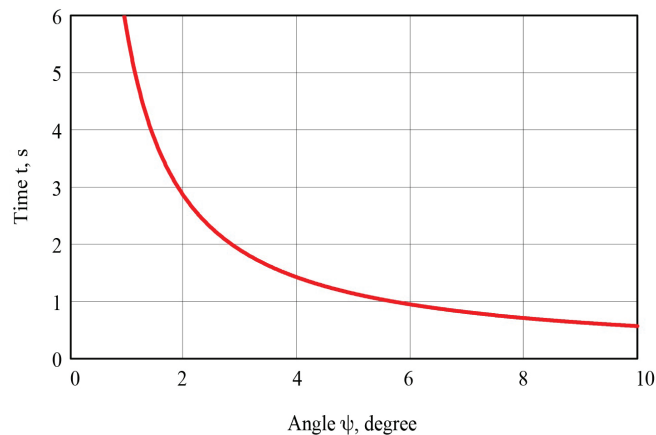

Fig. 6. Vehicle 1 driving time from the moment of collision to the moment of exit to the oncoming lane

In the case when the angle of rejection of V 1 is close to 1–3°, the time of departure of V 1 into the oncoming lane is 2...4.5 s. This time allows the driver of V 1 to apply braking and avoid entering the oncoming lane.

5. 3. Simulation results of the mechanism of tangential collision of vehicles

For additional analysis of the lateral tangential collision of V 1 against V 2, a computer model was built in the Cybid V-SIM software environment. Several variants of modeling the collision process of V 1 against V 2 at small angles of contact $\gamma=5^\circ$, 10° , and 15° were prepared (Fig. 7).

According to the results of computer simulation, the angle of rejection of V 1 due to the impact against V 2 was 0.9° (according to the estimation model, $1.5-3^\circ$), the time of movement of V 1 to the side due to the impact to the boundary of movement of vehicles in the opposite direction, was 6.8 s (according to the estimation model, 2–4.5 s).

According to the simulation results, the angle of deviation of V 1 due to the impact of V 2 was 3.8° (according to the estimation model, $4-6^\circ$), the time of movement of V 1 to the side due to impact to the boundary of the lane of vehicles in the oncoming direction amounted to 1.34 s (according to the estimation model, 1–1.5 s).

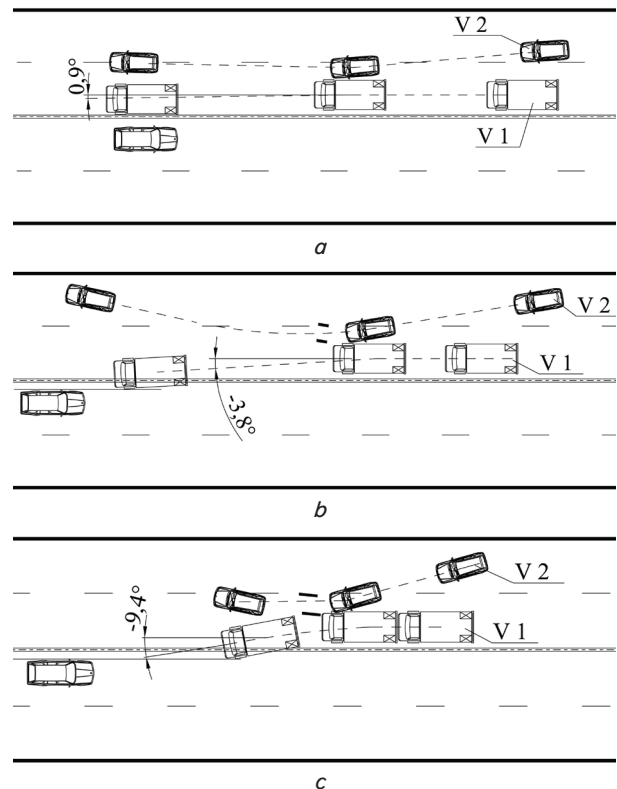

Fig. 7. Results of side-by-side tangential collision simulation in Cybid V-SIM software environment: a – at a collision angle value of $\gamma=5^\circ$; b – at the value of the angle of contact $\gamma=10^\circ$; c – at the value of the angle of contact $\gamma=15^\circ$

According to the results of computer modeling, the angle of rejection of V 1 due to the collision was 9.4° , which closely coincides with the range of the estimation model of $5-9^\circ$. The time of movement of V 1 sideways due to impact to the boundary of the lane of vehicles in the opposite direction was 0.65 s (according to the estimation model, 0.65–1 s).

6. Discussion of results of modeling a tangential collision of vehicles in the reconstruction of a traffic accident

Owing to the combination of the law of conservation of momentum and the theory of impact, it was possible to construct a mathematical model for the study of accidents in a lateral tangential collision of vehicles at low angles. The proposed mathematical model makes it possible to study cross-collisions in cases where there are no traces of sliding and braking. Unlike works [17, 18], where the dynamics of braking of vehicles with anti-lock braking systems is investigated, the proposed mathematical model makes it possible to solve a number of inverse problems in the reconstruction of an accident.

The results of our calculations, computer modeling, and reconstruction of the circumstances of a particular accident make it possible to draw certain quantitative conclusions:

1. Only at $\gamma=5^\circ$ the impact force due to the collision of V 1 against V 2 can be less than the friction force and the movement of V 1 in the lateral direction does not occur, in all other cases (at $\gamma=10^\circ$ and $\gamma=15^\circ$) there is an excess of the impact force over the friction force (Fig. 3), which means the movement of V 1 in the lateral direction with the loss of directional stability of movement.

2. The value of the lateral movement of V 1 as a result of the impact ranged from 0.047 m at $\gamma=5^\circ$ to 0.415 m at $\gamma=15^\circ$ (Fig. 4). That is, V 1 after the collision was within its lane.

3. As a result of the collision of V 1 and V 2, it deviated from the previous direction of movement:

a) with a collision angle value of $\gamma=5^\circ$, the calculated angle of rejection of V 1 was about $\psi=1.5-3^\circ$ (Fig. 5). According to the results of computer modeling, $\psi=0.9^\circ$ (Fig. 7). This range of rejection angles corresponds to the calculated values of the time interval $t=2...4,5$ s (Fig. 6). According to the results of computer modeling, $t=6.8$ s. This allows the driver of V 1 to apply braking and maneuver to avoid leaving the boundaries of his lane;

b) with a collision angle value of $\gamma=15^\circ$, the angle of rejection of V 1 was $\psi=5-9^\circ$ (Fig. 5). According to the results of computer modeling, $\psi=9.4^\circ$ (Fig. 7). This range corresponds to the values of $t=0.65...1$ s (Fig. 6). According to the results of computer modeling, $t=0.65$ s. This is equal to the sum of the driver's reaction time and the response time of the car's brakes, so the driver of V 1 could not avoid entering the oncoming lane;

c) at a collision angle of $\gamma=10^\circ$, the angle of disposition of V 1 was approximately $\psi=4-6^\circ$ (Fig. 5). According to the results of computer modeling, $\psi=3.8^\circ$ (Fig. 7). This range corresponds to the values of $t=1...1,5$ s (Fig. 6). According to the results of computer simulation, $t=1.34$ s. This is almost equal to the sum of the driver's reaction time and the response time of the car's brakes, so the driver of V 1 could not avoid entering the oncoming lane.

The constructed mathematical model is based on the law of conservation of impulses, which leads to certain limitations of its use. The proposed mathematical model can be used in collisions accompanied by minor deformations or damage to vehicles (collisions that are close to elastic).

When using the constructed mathematical model in practice, the following disadvantages should be taken into account. The accuracy of calculations is significantly influenced by such parameters as the duration of the collision of vehicles Δt and the recovery coefficient K_{imp} . Their values are usually inaccurate and are given in a certain range of values [1, 7]. Therefore, in the implementation of practical calculations, one should take into account these factors.

These shortcomings necessitate further research to reduce the impact of inaccurate values of the collision duration of vehicles Δt and the recovery coefficient K_{imp} on the accuracy of our result.

7. Conclusions

1. The problem of determining the possibility of losing directional stability of a vehicle and its movement in the lateral direction due to a cross-collision in the absence of slip

and braking marks on the road surface has been considered. This allows for the reconstruction of the circumstances of an accident in cases where the driver does not have enough time to use the brakes, which often occurs during a tangential collision of vehicles.

The methodology for calculating the impact force, exceeding which over the friction force will lead to the displacement of the vehicle due to a side collision to the oncoming lane or curb and loss of directional stability of movement, is given.

2. The constructed mathematical model of a lateral tangent collision of vehicles at low angles makes it possible, based on the speed of V 1 and V 2, the mass of V 1 and V 2, and the angle at which the collision occurred, to determine:

a) the magnitude of the lateral displacement of vehicles due to a side collision and the magnitude of the angle at which they move to the oncoming or passing lane, or curb;

b) the time of movement of vehicles into the oncoming lane at a distance sufficient for collision with vehicles moving in the oncoming or passing direction. This makes it possible to conclude that drivers have the technical ability to avoid certain consequences of an accident.

3. The results of the numerical calculation of vehicle traffic parameters according to the constructed mathematical model are consistent with the results of modeling the mechanism of lateral associated collision in the Cybid V-SIM software environment. Thus, for example, according to the results of computer simulation, at the value of the angle of contact $\gamma=15^\circ$, the angle of deviation of V 1 as a result of the impact against V 2 was 9.4° (according to the estimation model, $5-9^\circ$), the time of movement of V 1 to the side due to the impact to the boundary of movement of vehicles moving in the opposite direction was 0.65 s (according to the estimation model, 0.65–1 s). Modeling and calculation data are also consistent with the data on a real accident.

Conflict of interest

The authors declare that they have no conflict of interest in relation to this research, whether financial, personal, authorship or otherwise, that could affect the research and its results presented in this paper.

Financing

The study was conducted without financial support.

Data availability

The manuscript has no related data.

References

1. Ilarionov, V. A. (1989). *Ekspertiza dorozhno-transportnykh proisshествiy*. Moscow: Transport, 256.
2. Evtuyukov, S. A., Vasil'ev, Ya. V. (2006). *Ekspertiza dorozhno-transportnykh proisshествiy*. Sankt-Peterburg: Izd-vo DNK, 536.
3. Gidlewski, M., Prochowski, L., Jemioł, L., Zardecki, D. (2018). The process of front-to-side collision of motor vehicles in terms of energy balance. *Nonlinear Dynamics*, 97 (3), 1877–1893. doi: <https://doi.org/10.1007/s11071-018-4688-x>
4. Wei, T., Zhi-qiang, L., Ai-hong, Z., Liang, J. (2018). A simplified model for analysis of Side-impact Velocity Based on Energy Method. *IOP Conference Series: Materials Science and Engineering*, 392, 062126. doi: <https://doi.org/10.1088/1757-899x/392/6/062126>

5. Viba, J., Liberts, G., Gonca, V. (2009). Car Rollover Collision With Pit Corner. *Transport*, 24 (1), 76–82. doi: <https://doi.org/10.3846/1648-4142.2009.24.76-82>
6. Turenko, A. M., Klymenko, V. I., Saraiev, O. V., Danets, S. V. (2013). *Avtotekhnichna ekspertyza. Doslidzhennia obstavyn DTP*. Kharkiv: KhNADU, 320.
7. Rodionov, Yu. V., Novopisniy, E. A. (2015). *Metodiki ekspertnogo issledovaniya stolknoveniy transportnykh sredstv*. Penza: PGUAS, 188.
8. Wach, W. (2020). Spatial Impulse-Momentum Collision Model in Programs for Simulation of Vehicle Accidents. 2020 XII International Science-Technical Conference AUTOMOTIVE SAFETY. doi: <https://doi.org/10.1109/automotivesafety47494.2020.9293494>
9. Vangi, D., Begani, F., Spitzhüttl, F., Gulino, M.-S. (2019). Vehicle accident reconstruction by a reduced order impact model. *Forensic Science International*, 298, 426.e1–426.e11. doi: <https://doi.org/10.1016/j.forsciint.2019.02.042>
10. Chen, Q., Xie, Y., Ao, Y., Li, T., Chen, G., Ren, S. et al. (2021). A deep neural network inverse solution to recover pre-crash impact data of car collisions. *Transportation Research Part C: Emerging Technologies*, 126, 103009. doi: <https://doi.org/10.1016/j.trc.2021.103009>
11. Strother, C. E., Woolley, R. L., James, M. B., Warner, C. Y. (1986). Crush Energy in Accident Reconstruction. SAE Technical Paper Series. doi: <https://doi.org/10.4271/860371>
12. Wach, W., Gidlewski, M., Prochowski, L. (2016). Modelling reliability of vehicle collision reconstruction based on the law of conservation of momentum and Burg equations. Proceedings of 20th International Scientific Conference. *Transport Means 2016*, Part II. Kaunas University of Technology Publisher, Kaunas 2016, 693–698. Available at: https://www.researchgate.net/publication/321071413_Modelling_Reliability_of_Vehicle_Collision_Reconstruction_Based_on_the_Law_of_Conservation_of_Momentum_and_Burg_Equations
13. Dong, H.-C., Nie, Z.-G. (2017). Identification for Speed of Vehicle and Its Uncertainty Analysis of Road Traffic Accident by Momentum Method. *DEStech Transactions on Computer Science and Engineering*. doi: <https://doi.org/10.12783/dtcse/csma2017/17373>
14. Povaliaiev, S., Saraiev, O. (2021). Mathematical model for estimation the stability of the vehicle's motion on overturning. *Vehicle and Electronics. Innovative Technologies*, 19, 47–52. doi: <https://doi.org/10.30977/veit.2021.19.0.47>
15. Li, B., Bei, S. (2019). Research method of vehicle rollover mechanism under critical instability condition. *Advances in Mechanical Engineering*, 11 (1), 168781401882121. doi: <https://doi.org/10.1177/1687814018821218>
16. Imine, H., Benallegue, A., Madani, T., Srairi, S. (2014). Rollover Risk Prediction of Heavy Vehicle Using High-Order Sliding-Mode Observer: Experimental Results. *IEEE Transactions on Vehicular Technology*, 63 (6), 2533–2543. doi: <https://doi.org/10.1109/tvt.2013.2292998>
17. Saraiev, O., Gorb, Y. (2018). A Mathematical Model of the Braking Dynamics of a Car. SAE Technical Paper Series. doi: <https://doi.org/10.4271/2018-01-1893>
18. Danez, S., Saraiev, O. (2018). Mathematical modeling of speed change of vehicles at emergency braking. *Technology Audit and Production Reserves*, 3 (1 (41)), 22–28. doi: <https://doi.org/10.15587/2312-8372.2018.133612>