

IMPROVEMENT OF THE MANUFACTURING METHOD OF MULTI-COMPONENT PASTE-LIKE VEGETABLE SEMI-FINISHED PRODUCTS WITH A HIGH DEGREE OF READINESS

Nina Rudska

Corresponding author

PhD, Senior Lecturer

Department of Botany, Genetics and Plant Protection

Vinnitsia National Agrarian University

Sonyachna str., 3, Vinnitsia, Ukraine, 21008

E-mail: nina_rudska@ukr.net

Oleksander Cherevko

Doctor of Technical Sciences, Professor

Adviser to the Rector**

Andrii Pugach

Doctor of Science in Public Administration, Professor, Dean***

Nataliia Ponomarenko

PhD, Associate Professor

Department of Tractors and Agricultural Machines***

Hennadii Tesliuk

PhD, Associate Professor

Department of Tractors and Agricultural Machinery***

Ruslan Zakharchenko

PhD, Associate Professor

Department of Automation, Electronics and Telecommunications

National University «Yuri Kondratyuk Poltava Polytechnic»

Pershotravnivnyi ave., 24, Poltava, Ukraine, 36011

Alexander Postadzhiev

Postgraduate Student*

Nataliia Tytarenko *

*Department of Equipment and Engineering of Processing and Food Production**

**State Biotechnological University

Alchevskykh str., 44, Kharkiv, Ukraine, 61002

***Dnipro State Agrarian and Economic University

Serhiya Yefremova str., 25, Dnipro, Ukraine, 49600

The object of the study is a multi-component paste-like semi-finished product based on apples, Jerusalem artichokes, cranberries and hawthorn, which are natural nutrients with original properties obtained by cooking at 55–60 °C in an experimental vacuum-evaporator.

The method of production of a multi-component semi-finished product has been improved by keeping hawthorn in a 10...15 % NaCl solution with the addition of 1 % citric acid at 20...25 °C for 30...45 minutes. Blanching with hot steam at a temperature of 105...110 °C is carried out for: apple (2...3 min), Jerusalem artichoke (5...8 min) and hawthorn (4...6 min), and cranberries are blanched with water for 1.5...3 min at temperatures of 80...90 °C. Wiping the components followed by recipe-component blending and boiling at 55...60 °C in an experimental vacuum-evaporator.

According to the organoleptic parameters, the puree blend containing: apple – 35 %, Jerusalem artichoke – 30 %, cranberry – 25 % and hawthorn – 10 % with a yellow-orange color has the advantage. The ultimate shear stress (pureed components, Pa) is: apple – 14, Jerusalem artichoke – 322, cranberry – 75, hawthorn – 445. The boiled paste mixture has an increased viscosity by 3.5 times compared to the control.

The heating of the working chamber and the stirrer of the vacuum-evaporating apparatus is carried out by a film resistive electronic heater of the radiating type, providing stabilization of the temperature effect and a 45 % increase in the boiling efficiency compared to the classic vacuum apparatus. The improved method will expand the range of competitive semi-finished products of a wide range of applications with natural nutrients and regulated rheological and functional properties, which will contribute to the production of food products with an immunomodulating effect

Keywords: blends of purees and pastes, vacuum evaporator, nutrient composition, functional ingredients

Received date 12.12.2023

Accepted date 12.02.2023

Published date 28.02.2023

How to Cite: Rudska, N., Cherevko, O., Pugach, A., Ponomarenko, N., Tesliuk, H., Zakharchenko, R., Postadzhiev, A., Tytarenko, N. (2023).

Improvement of the manufacturing method of multi-component paste-like vegetable semi-finished products with a high degree of readiness.

Eastern-European Journal of Enterprise Technologies, 1 (11 (121)), 41–49. doi: <https://doi.org/10.15587/1729-4061.2023.273673>

1. Introduction

Rational nutrition is an integral part of the life of European countries, taking into account the decrease in physical activity, the influence of various environmental and post-pandemic circumstances, which lead to the rapid development of various diseases. In addition, it is the use of innovative hardware and technological solutions that allow implementing a nutrient-based approach to the formation of a “health” diet [1]. And the use of natural ingredients will allow not only to minimize the seasonality of the use

of natural “health” food, but also to increase the content of functional ingredients, biologically active substances, strengthening the resistance of the consumer’s body to today’s challenges. Natural plant raw materials of various types: vegetables, fruits, berries, spicy-aromatic, etc., will ensure the production of competitive semi-finished products of a high degree of readiness with functional properties, predicted structural-mechanical and organoleptic properties. The production of multi-component semi-finished products of a high degree of readiness from own raw materials under the conditions of optimal equipment and technological solu-

tions will expand the range of both independent products and provide the possibility of their inclusion in the recipes of various food products [2]. Including: dairy, confectionery, meat and others, the recipes of which allow the inclusion of natural semi-finished products of a high degree of readiness in the conditions of replacement of certain recipe components, ensuring an increase in nutritional value. The implementation of innovative resource-efficient solutions for the implementation of methods for the production of “health” semi-finished products of a high degree of readiness will form innovative rational approaches for processing one’s own raw material base with maximum preservation of biologically active substances.

Multi-component vegetable semi-finished products of a high degree of readiness are characterized by the properties of both an independent product ready for use and as components in the recipes of various products, that is, they are products of a wide range of demand. At the same time, consumers prefer modern trends in “healthy” food based on natural plant raw materials with adjustable composition and original organoleptic properties due to the nutrient blending of natural components. This determines the urgency of finding innovative ways to improve the method of production of multi-component plant semi-finished products with a high degree of readiness.

2. Literature review and problem statement

In the review [3] data on the effectiveness of the use of plant raw materials in the form of functional food products for the formation of a rational diet due to the content of various biologically active nutrients for health and medical and preventive purposes are given. It is noted that consumers are aware of the need for rational nutrition, regardless of age, which is due to a decrease in the immune component due to the deterioration of the ecological situation and current pandemic challenges [4]. The production of multifunctional products with a high degree of readiness is possible under the conditions of using modern innovative hardware and technological solutions in a single component and taking into account the available assortment, quality and preferences of consumers. The latter is the “driving” force for the development of the food industry in the production of quality products of a wide range of uses, taking into account resource-efficient technologies. Ensuring the use of rational hardware and technological solutions during production affects the final quality of food products, preservation of functional nutrients and competitiveness [5]. In publications [6, 7], the main shortcomings of traditional technological equipment for the processing of plant raw materials are indicated, namely: significant metal capacity, the presence of intermediate heat carriers, unevenness of the temperature field, etc., which significantly affect the quality of the final products. This emphasizes experimental and practical research aimed at finding resource-efficient hardware and technological solutions for processing the raw material base of plant raw materials into multi-component semi-finished products of a high degree of readiness with an increased and regulated nutrient composition.

The work [8] takes into account the impact of a complex environmental situation, which causes the creation of semi-finished products of plant origin, taking into account the proposed solution aimed at improving the processes of

processing raw materials due to the technical re-equipment of enterprises. The above researches make it possible to improve the technological equipment for the production of fruit powders due to effective thickening in a rotary-film apparatus to a dry matter (DM) content of 30...40 %, as well as further drying in a roller IR dryer to a dry matter content of 85...92 %. The obtained vegetable powder-like semi-finished products are characterized by an increased content of biologically active substances, however, the features of mixing raw materials to obtain the necessary nutrient composition are not fully specified, emphasizing the relevance of research in this direction. In work [9], generalized data on the implementation of innovative hardware and technological solutions for the production of special-purpose food products are given. However, the issues related to the possibility and relevance of using for the production of “health” multifunctional semi-finished products with a high degree of readiness of the country’s own raw material base and a possible corresponding assortment of products remain to be noted. It is the improvement of methods of production of multi-component semi-finished products of a high degree of readiness, including in the conditions of selection of a rational nutrient composition taking into account resource-efficient technologies that will ensure competitive demand for finished products. The paper [10] presents a heat-mass transfer model for the concentration of vegetable raw materials in a film evaporator depending on the technological parameters. However, possible ways to increase resource efficiency, taking into account various methods of heat supply and uniformity of the temperature field, as one of the factors of the quality of heat and mass exchange processing, are still to be considered, emphasizing the need for research in this direction. The paper [11] provides an analysis of heat transfer in a non-Newtonian pseudoplastic fluid during processing in a scraper heat exchanger under the conditions of ensuring increased heat exchange depending on the consumption of electricity. However, the main conclusions emphasize the achievement of technological needs without prior determination and consideration of the heat transfer coefficient as a factor affecting the duration of the process and resource efficiency. This determines the need to determine the rational conditions of heat supply, taking into account the thermophysical and rheological properties of blended raw materials and the method of heat supply to achieve the production of competitive plant products. For example, in work [12] it is noted that most vacuum-evaporating devices for concentration need to solve the problem of stabilizing the heat supply. This is due to the presence of the use of intermediate heat carriers, in most cases vaporous, characterized by complex stabilization of the temperature effect and the absence in most cases of an increased heat exchange surface due to additional heating of the stirrer. One of the ways to eliminate these shortcomings is the use of a modern film resistive electric heater of the radiating type (FREHTP) [13], which is characterized by the absence of a metal-intensive component, and therefore low inertia, ease of operation and uniformity of the temperature field.

In the literary source [14], attention is focused on the well-founded search for a natural raw material base with a high content of functional ingredients and original organoleptic properties for the formation of a health and preventive diet. The difficulty of obtaining original vegetable multicomponents of a high degree of readiness is due to the natural properties and peculiarities of blending to provide

the predicted rheological structure. So, for example, for the production of dried semi-finished products of vegetable origin, there is a single-drum cylindrical IR dryer for drying pre-concentrated pastes [15]. The peculiarity of using the device is the direct supply of raw materials to the working surface and drying in the IR field from the FREHTP, which is installed on the inner surfaces of the corrugated drum and the cylindrical casing. It is noted that the average drying time of blended paste with a dry matter content of 45 % at a temperature of 65 °C and different thicknesses of its application on the work surface (8, 6, and 4 mm) should be 75, 60, and 56 minutes, respectively. The indicated indicators of color changes of the samples confirm the possibility of using the dryer to obtain high-quality plant semi-finished products of the dried fraction.

Multi-component semi-finished products of various consistencies with a high degree of readiness are used in the processing, food and pharmaceutical industries, since the introduction of synthetic components into recipes minimizes the natural nutrient composition and provides original organoleptic properties. Existing confectionery technologies use expensive raw materials, which increase the cost and reduce the health properties of synthetic substances, confirming the need to find ways to produce semi-finished products with a high degree of readiness from one's own natural raw materials [16].

Researchers [17] consider the effectiveness of improving marshmallow technology by adding mixed fruit and vegetable paste to its recipe. A method of producing a fruit and vegetable past-like semi-finished product based on apple, pumpkin and beet is proposed under the conditions of concentration at a temperature of 50...55 °C in a rotary-film apparatus to a content of 45 % DM within 1.25...2.0 min. The expediency of using fruit and vegetable paste in the recipe of marshmallows in the amount of 75 % as a substitute for applesauce is confirmed. The resulting marshmallow products are characterized by an increased natural nutrient composition and original organoleptic properties. In the scientific decision [18], the effect of adding grape skin to the jelly-like candies recipe is determined. It has been established that the extracts reduce the duration of processing and increase the content of natural nutrients, giving the product original organoleptic properties. However, the influence of the admixture on the shelf life and indication of the regime parameters of the extracts remains to be noted, not allowing a full assessment of the change in biologically active substances at the production stages, predisposing research in this direction. The study [19] indicates the effectiveness of the use of blended paste in the formulation of lozenges, which ensures an increase in the natural nutrient composition, confirming the need for research aimed at the rational production of multi-component semi-finished products of a high degree of readiness. It should be noted that during the production of confectionery products based on semi-finished products of a high degree of readiness, it is necessary to ensure a uniform consistency, which is implemented in various mixers, tempering machines, etc. [20].

Plant semi-finished products allow to use them as components and fillers in various branches of food production, confectionery, dairy, meat, etc. The well-founded composition of plant raw materials makes it possible to obtain a universal semi-finished product with predetermined properties for its purposeful use in pastille and marmalade [17, 19], culinary meat [21], bakery products [22], processed cheeses [23], etc.

Such solutions will make it possible to obtain products with original organoleptic properties with increased nutritional value. The key to preserving the initial properties of plant raw materials is the use of gentle temperature regimes and appropriate hardware solutions. Researchers in work [24] note that the implementation of the hardware and technological component affects the competitive performance of products, in particular meat delicacies with original organoleptic properties, confirming the wide range of use of natural semi-finished products with a high degree of readiness. Therefore, one of the priority tasks of the modern processing and food industry is the implementation of innovative hardware and technological solutions for the production of "healthy" food products of a high degree of readiness, based on its own raw materials of natural origin.

Plant raw materials are a natural source of useful substances, therefore, when creating paste-like blended semi-finished products, it is necessary to take into account the chemical composition and organoleptic indicators of the selected raw materials. The selection of raw materials must first of all take into account the content of pectin, vitamin C, taste, color and consistency, which will lead to obtaining a high-quality functional semi-finished product with a wide range of uses when blended. For further research, it is proposed to use own plant raw materials (apple, Jerusalem artichoke, cranberry, and hawthorn) with a high content of useful substances, including pectin, vitamin C, and other functional ingredients [25–27]. It should be noted that the production of multi-component semi-finished products of a high degree of readiness also requires consideration of the issue of packaging, taking into account the rheological properties of the product and consumer interest in packaging in the context of the European rate of waste reduction. The work [28] describes the development of the design and form of packaging of food products taking into account the level of packaging waste. The relationship between the consumption of food products and the features of packaging while minimizing the level of waste is also investigated, taking into account automated technologies for obtaining light-proof packaging [29], including from pressed paper, fast-degrading film, etc. The effectiveness of packaging, taking into account the characteristics of food products and products, the level of processing speed of packaging for European countries, plays a significant role in the conditions of environmental protection.

The use of multi-component semi-finished products with a high degree of readiness, both independent products and prescription supplements or substitutes for synthetic ingredients, ensures an increase in the content of functional ingredients and provides original organoleptic properties to competitive "health" products. Therefore, the improvement of the method of production of multi-component plant semi-finished products of a high degree of readiness is a well-founded direction of scientific, practical and experimental research.

3. The aim and objectives of research

The aim of research is to improve the method of production of a multi-component past-like vegetable semi-finished product with a high degree of readiness. This will make it possible to expand the natural nutrient assortment of multi-component semi-finished products of a high degree

of readiness as independent products and supplements to the recipes of various food products to enrich the nutrient composition.

To achieve the aim, the following objectives are set:

- to justify the recipe composition and method of production of a paste-like vegetable semi-finished product with determination of its organoleptic and rheological properties;
- to investigate the process of cooking a multi-component paste-like semi-finished product on an experimental model of a vacuum evaporation apparatus.

4. Materials and methods of research

Research center were implemented in the “New biotechnologies and equipment for the production of food products with high health-improving properties” of the State Biotechnology University (Kharkiv, Ukraine).

The object of the study is a multi-component vegetable paste-like semi-finished product with a high degree of readiness based on: apples (Antonivka variety), Jerusalem artichoke (White variety), cranberries (Pilgrim variety) and blood-red hawthorn, which are sources of natural functional ingredients. The chemical composition is presented in the Table 1 [25–27]. Kharkiv region’s own raw material base was used to form a multi-component vegetable semi-finished product with a high degree of readiness.

Table 1

Chemical composition of components for further production of multi-component vegetable paste-like semi-finished products with a high degree of readiness [25–27]

Physiologically functional ingredients	Raw material (100 g)			
	Apple	Artichoke	Cranberry	Hawthorn
vitamin A, µg	5.0	2.0	3.0	4.0
vitamin C, mg	10.0	6.0	13.3	31.5
vitamin PP, mg	0.3	1.3	0.2	42.0
Phosphorus, mg	11.0	83.0	13.0	–
Calcium, mg	16.0	18.0	8.0	30.0
Potassium, mg	27.8	44.0	85.0	13.1
Dietary fibers, gr	1.8	4.5	3.3	2.0
Organic acids, gr	0.8	0.1	3.1	0.3
Calorie content, kcal	44.0	75.0	28.0	62.0

At the same time, multicomponentity was achieved by experimental blending of components in the composition taking into account the rheological properties (limiting shear stress and effective viscosity) determined on the rotary viscometer “Rheotest-2” (Germany) and organoleptic properties evaluated by an expert commission of 5 people. The main research hypothesis is the possibility of improving the method of production of a multi-component plant semi-finished product of a high degree of readiness in the conditions of resource-efficient processing. Thus, it is possible to ensure the expansion of the assortment of “health” independent and prescriptive supplements to the prescriptive composition of various food products.

The production of multi-component plant semi-finished products of a high degree of readiness was carried out in accordance with the recipe ratio (Table 2) and the principle scheme (Fig. 1) under the conditions of implementa-

tion of equipment and technological recommendations. For high-quality control of the cooking process in the model design of the vacuum evaporation apparatus, an automated microcontroller from the company “Aries” (Kharkiv, Ukraine) was used to measure and regulate temperature changes, the frequency of rotation of the stirrer, and the consumption of the mass of the cooked paste. All studies had a five-fold repeatability and were characterized by a relative error of no more than 3 percent using the traditional method of processing experimental and practical data.

5. Research results on improving the method of production of multi-component paste-like vegetable semi-finished products with a high degree of readiness

5.1. Determination of the recipe ratio of plant raw materials and changes in rheological properties during blending

Blending of a multi-component vegetable paste-like semi-finished product with a high degree of readiness was carried out in accordance with the proposed recipe ratio of components (Table 2), taking into account the rheological, nutritional and organoleptic properties of each blended component and the proposed method (Fig. 1).

Table 2

Recipe-component composition of a multi-component vegetable paste-like semi-finished product with a high degree of readiness

Recipe-component composition, %	Blend		
	A	B	C
Apple	25	35	45
Jerusalem artichoke	25	30	35
Cranberry	35	25	15
Hawthorn	15	10	5
Control	100	100	100

The improved method of production of a multi-component vegetable paste-like semi-finished product with a high degree of readiness was implemented as follows: ripe raw materials are sent for washing, further inspection and cutting for further blanching. Hawthorn is kept in a 10...15 % NaCl solution with the addition of 1 % citric acid at a temperature of 20...25 °C for 30...45 minutes to stabilize polyphenols. Raw materials are also blanched with hot steam at a temperature of 105...110 °C: apples (2...3 min), Jerusalem artichoke (5...8 min) and hawthorn (4...6 min), and cranberries are blanched with water for 1.5...3 min at a temperature of 80...90 °C.

In the future, the process of grinding all components to a particle size of 0.3...0.5 10^{-3} m and further recipe-component blending is implemented according to the Table 2. A homogeneous, multi-component puree-like mass is submitted for further cooking at a temperature of 55...60 °C to a dry matter content of 30...32 % in an experimental installation of a vacuum evaporation apparatus. After that, it is packed in a light-proof hermetic container with simultaneous heat treatment and sent for further sale.

The waste during wiping is sent to the auxiliary technological operation of drying the pomace in an IR field at a temperature of 50 °C to a final moisture content of 6...10 % of dry matter. Dried squeezes are sent for packaging and fur-

ther sale in accordance with the technological needs of the processing, food and pharmaceutical industries.

For further investigation of the process of cooking a multicomponent vegetable semi-finished product, the organoleptic properties of multicomponent purees were determined on an experimental model of a vacuum evaporation apparatus (Table 3).

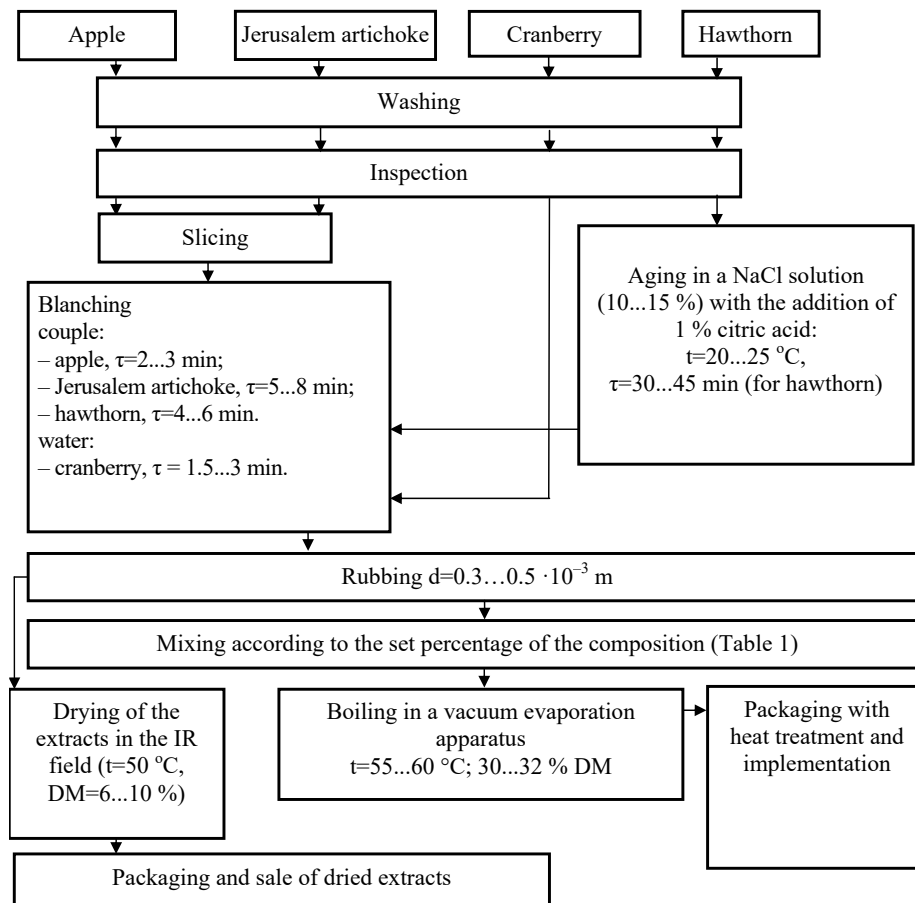

Fig. 1. Schematic diagram of the production of a multi-component vegetable paste-like semi-finished product with a high degree of readiness based on apple, Jerusalem artichoke, cranberry and hawthorn

Analyzing the organoleptic properties of multicomponent purees confirms that the test samples have a structured, homogeneous consistency. In terms of color and taste-aromatic indicators, blend B with the following content: apple – 35 %, Jerusalem artichoke – 30 %, cranberry – 25 % and hawthorn – 10 % is preferred. Changes in the recipe ratio in blends A and B lead to organoleptic properties, in particular color and taste.

For high-quality cooking (30...32 % DM) and implementation of heat-mass exchange processing of the proposed multi-component fruit and vegetable semi-finished product with a high degree of readiness based on blended components, the rheological behavior of the puree of each component was determined. In Fig. 2, the results of the characteristics of the ultimate shear stress and their comparison with the control – applesauce for determining the ultimate shear stress (Θ , Pa) are given.

The ultimate shear stress of the puree of the selected fruit and vegetable raw materials included in the proposed recipe was determined: apple – 14 Pa, Jerusalem artichoke – 322 Pa, cranberry – 75 Pa, hawthorn – 445 Pa, which by nature of dependence have properties, because the samples have a yield point, their structure is destroyed not immediately after application of shear forces, but gradually as the velocity gradient increases.

Fig. 3 shows the dependence of the dynamic viscosity on the shear rate of the experimental samples (mash and paste), which has the best organoleptic indicators (recipe blend B). Apple puree and paste were selected as controls.

Table 3
Comparative properties of organoleptic evaluation of multicomponent purees obtained according to the component-recipe ratio (Table 2)

Evaluation index	Blend		
	A	B	C
Appearance	homogeneous puree-like mass		
Taste and smell	harmonious taste of Jerusalem artichoke and apple, audible taste of hawthorn and cranberry	Pleasant harmonious taste of Jerusalem artichoke with light notes of apple and cranberry	Pronounced Jerusalem artichoke smell and taste
Color	pronounced yellow-orange	Pleasant yellow-orange	Light shade of yellow-orange
Consistence	Homogeneous viscous mass with a structured structure that does not spread		

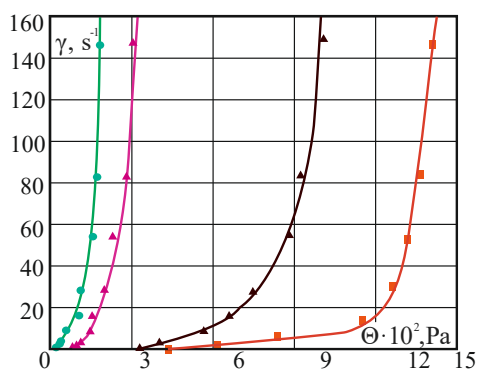

Fig. 2. Characteristics of the ultimate shear stress of puree components of raw materials of the proposed multi-component vegetable semi-finished product at room temperature ($t=22\text{ }^{\circ}\text{C}$): ● – apple; ▲ – Jerusalem artichoke; ▲ – ranberry; ■ – hawthorn

Measurements were carried out after mixing the recipe components of the puree and after boiling the already obtained paste with a dry matter content of 30 % in comparison with the control of puree and apple paste, respectively.

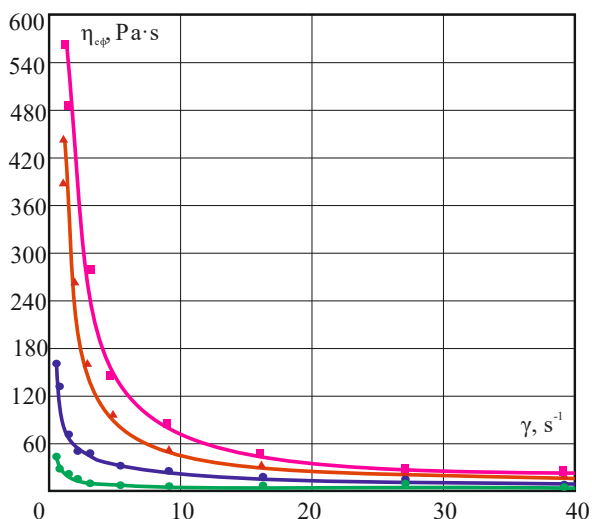

Fig. 3. Complete rheological curves of vegetable semi-finished products, $t=22\text{ }^{\circ}\text{C}$: ● – control (apple puree 9 % of dry substances); ● – control (apple paste 30 % of dry substances); blend B: ▲ – 18 % of dry substances; ■ – 30 % of dry substances

The obtained structural and mechanical indicators of the experimental sample of cooked pasta (blend B) show an increase in effective viscosity by 27 % compared to the original blend of puree of selected fruit and vegetable raw materials.

The selected experimental composition of puree after blending has a stronger structure (447 Pa·s) compared to the control (apple puree – 43 Pa·s). After boiling to a dry matter content of 30 %, the obtained blend also shows a significant 3.5-fold increase in structural strength (568 Pa·s) compared to the control (apple paste 30 % DM – 165 Pa·s). In general, the level of the indicator of the intact structure of the effective viscosity indicates the structure-forming abilities of the proposed blend of paste, which will contribute to their further recommendation as an additive and filler in various confectionery products. The obtained structural and mechanical indicators are necessary for further calculation and design of evaporation equipment for a more efficient cooking process of the developed semi-finished product.

5. 2. Aprobation of the process of boiling a multi-component vegetable semi-finished product in a vacuum evaporation apparatus

To test the process of cooking a multi-component vegetable semi-finished product, it is proposed to determine the efficiency of using the model design of the vacuum evaporation apparatus presented in Fig. 4. The heating of the working chamber of the vacuum-evaporator 2 and the stirrer 3 is provided by a film resistive electric heater of the radiating type (FREHTP). Loading of multicomponent vegetable puree is carried out by loading hopper 1. The rotation of the stirrer is ensured by an electric motor 9 with a frequency meter 10, the values of the rotation frequency are displayed and adjusted using the measuring unit 8. Using the unit 8, heat treatment during cooking is controlled by thermocouples 4. In the lower part of the

vacuum-evaporator device for measuring boiled multi-component vegetable past-like semi-finished product of a high degree of readiness 5 is mounted on the evaporator, which is connected to the storage tank 6.

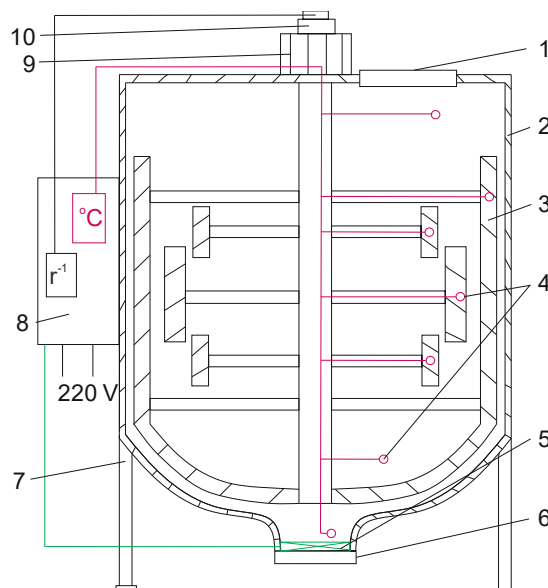

Fig. 4. Scheme of the model design of the vacuum evaporation apparatus: 1 – loading hopper; 2 – body of the apparatus, which is heated by the FREHTP; 3 – stirrer, which is heated by FREHTP; 4 – thermocouples; 5 – device for measuring boiled pasta; 6 – storage capacity; 7 – stable; 8 – measuring unit (temperature, stirrer rotation frequency, consumption of raw materials and vacuum); 9 – electric motor; 10 – frequency sensor

The comparative characteristics of the kinetics of heating to the stationary boiling temperature in the experimental design of the vacuum evaporator and the traditional evaporator MZS-320 are shown in Fig. 4.

The presented dependencies testify to more effective management of the heating process in the proposed device with an improved housing heating scheme and a stirring device with FREHTP heating. Shown in Fig. 4 indicators indicate a reduction in the time of heating the initial puree to the boiling temperature under vacuum (55 °C) in the experimental equipment by 45 % compared to the traditional design. The resulting decrease in the duration of heating is explained by a larger heat transfer surface due to the heating of the stirrer and a lower metal capacity due to the absence of a steam-water shell of the experimental apparatus.

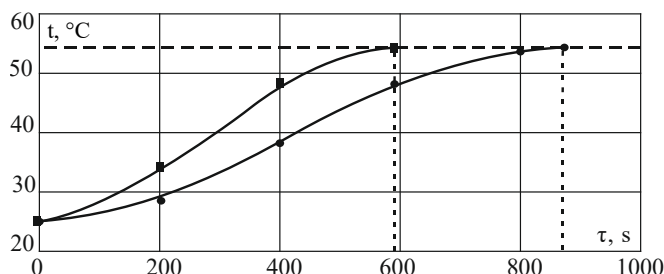

Fig. 5. Comparative characteristics of the heating kinetics of fruit and vegetable puree blend: ■ – experimental vacuum-evaporation apparatus; ● – prototype MZS-320

6. Discussion of the results of the improvement of the method of production of multi-component vegetable paste-like semi-finished products with a high degree of readiness

The obtained results are explained by the formation of a rational recipe composition in the production of a natural blend from its own raw material base under the conditions of using approbation solutions when comparing 3 blends (Table 2). It was established that the optimal blend in terms of organoleptic properties is: 35 % apple, 30 % Jerusalem artichoke, 25 % cranberry and 10 % hawthorn (Table 3). The preliminary determination of the ultimate stress of recipe blends (Fig. 2) allows to predict the nature of the complete rheological curves of vegetable blended semi-finished products (Fig. 3), with confirmation that the proposed blend has the maximum effective viscosity compared to the control. A feature of the method is keeping hawthorn in a 10...15 % NaCl solution with the addition of 1 % citric acid at a temperature of 20...25 °C for 30...45 minutes to stabilize polyphenols. Blanching raw materials with hot steam at a temperature of 105...110 °C: apples (2...3 min), Jerusalem artichoke (5...8 min) and hawthorn (4...6 min), and cranberries are blanched with water for 1.5...3 min per temperatures of 80...90 °C (Fig. 1). With further boiling of the multi-component pureed mass at a temperature of 55...60 °C in an experimental installation of a vacuum evaporation apparatus (Fig. 4) to 30...32 % of dry matter. At the same time, the wiping waste is dried in an IR field at a temperature of 50 °C to a final moisture content of 6...10 % dry matter. To determine and confirm the efficiency of boiling in the proposed model of a vacuum-evaporating apparatus based on FREHTP, the kinetics of heating to a stationary boiling temperature of 55 °C were obtained in comparison with the traditional vacuum-evaporating apparatus MZS-320 (Fig. 4). The obtained data confirm the reduction of the temperature effect by 45 %, and therefore the "harmful" temperature effect on the nutrient composition of natural raw materials, increasing the quality of the obtained products.

The production of competitive semi-finished products with a high degree of readiness depends on the use of rational hardware and technological solutions, which in most cases are characterized by high hardware energy and metal consumption [5, 7]. In particular, the use of a model design of a vacuum-evaporator based on FREHTP and an additional increase in the heat exchange surface due to the heating of the stirrer will ensure an increase in the resource efficiency of the process under the conditions of elimination of intermediate coolants at a uniform temperature field. In contrast to the well-known method of boiling in a traditional vacuum-evaporator [30] using simulation modeling, in practice, unfortunately, it is impossible to predict the obtained quality. Since computer modeling and practical testing has its own peculiarities of the implementation of the cooking process, the paper presents the comparative characteristics of the kinetics of heating the fruit and vegetable puree blend in the proposed apparatus with the traditional MZS-200. It confirms the effectiveness of the proposed constructive solutions, in particular the use of FREHTP. Regarding the technological component, the wide range of use of high-quality natural semi-finished products in various technologies of food products [31, 32] still requires a reasonable approach, especially in the selection of raw materials when using blends. Blending according to the previously developed

recipe and provision of equipment and technological components will allow to obtain a high-quality semi-finished product for health purposes, which corresponds to the sequence of scientific and practical research.

The obtained solutions are related to the use of an improved method of production of multi-component plant semi-finished products of a high degree of readiness, which will allow the use of the countries' own raw material base. This will allow to expand the range of products of natural origin of our own production, minimize synthetic impurities in the recipes of food products and form a functional diet to strengthen the immune component in the face of today's environmental challenges. The rational blending of our own raw material base of natural raw materials will allow to create functional and therapeutic-prophylactic products with original organoleptic properties in various areas of nutrition. In addition, the use of resource-efficient hardware and technological solutions, in particular under the conditions of low-temperature processing, increasing the area of interaction with the heating medium (mixer heating) and the use of modern raw material packaging technologies will ensure its competitiveness. The limitations of the study for the production of competitive products with a high degree of readiness in practice are the consideration of the functional properties of natural raw materials and the nutrient composition during rational blending in compliance with daily consumption norms. The need to predict rheological properties, organoleptic indicators and the method of packaging of semi-finished products with a high degree of readiness complicates a rational approach when mixing multicomponent blends of natural origin. Failure to comply with the recommended production methods and recipe ratios will inevitably lead to a decrease in the competitive properties of any products using the resulting semi-finished product.

One of the shortcomings of experimental and practical research is the lack of formed generalized features of the implementation of cooking, in particular, when using other regime parameters and equipment complexes, when producing high-quality semi-finished products of a high degree of readiness.

The further development of the research will consist in the rationalization of the mode parameters of blended purees during cooking, taking into account the natural properties, duration and storage conditions, taking into account modern packaging technologies.

7. Conclusions

1. The recipe composition and method of production of a vegetable multi-component semi-finished product with a high degree of readiness, which includes in its composition: apple – 35 %, Jerusalem artichoke – 30 %, cranberry – 25 % and hawthorn – 10 %, are substantiated. The method is distinguished by operations of preliminary heat treatment of raw materials and the use of a resource-efficient model of a vacuum-evaporating device for cooking at temperatures of 55...60 °C. The paste concentrated on the experimental setup has a viscosity index of the unbroken structure – 568 Pa·s, which is almost 3.5 times more than the control apple paste – 165 Pa·s.

2. By studying the cooking process of a multi-component past-like semi-finished product on an experimental model of

a vacuum evaporation apparatus, the characteristics of the kinetics of heating to a stationary boiling temperature of 55 °C were obtained in comparison with the traditional vacuum evaporation apparatus MZS-320. The determined results indicate a decrease in the duration of heating to the boiling temperature under vacuum (55 °C) in the proposed model of the apparatus by 45 % compared to the traditional one.

Conflict of interest

The authors declare that there is no conflict of interest regarding this research, including financial, personal, authorship, or any other nature that could link the research and its results presented in this article.

Financing

The study was conducted without financial support.

Availability of data

The manuscript has no associated data.

Acknowledgments

The work was carried out within the framework of the state budget topic No. 4-22-23 BO “Innovative technologies of preservation and processing of plant raw materials into safe special purpose products”.

References

- Galanakis, C. M., Rizou, M., Aldawoud, T. M. S., Ucak, I., Rowan, N. J. (2021). Innovations and technology disruptions in the food sector within the COVID-19 pandemic and post-lockdown era. *Trends in Food Science & Technology*, 110, 193–200. doi: <https://doi.org/10.1016/j.tifs.2021.02.002>
- Munekata, P. E. S., Pérez-Álvarez, J. Á., Pateiro, M., Viuda-Matos, M., Fernández-López, J., Lorenzo, J. M. (2021). Satiety from healthier and functional foods. *Trends in Food Science & Technology*, 113, 397–410. doi: <https://doi.org/10.1016/j.tifs.2021.05.025>
- Pap, N., Fidelis, M., Azevedo, L., do Carmo, M. A. V., Wang, D., Mocan, A. et al. (2021). Berry polyphenols and human health: evidence of antioxidant, anti-inflammatory, microbiota modulation, and cell-protecting effects. *Current Opinion in Food Science*, 42, 167–186. doi: <https://doi.org/10.1016/j.cofs.2021.06.003>
- Marcus, J. B. (2013). Life Cycle Nutrition: Healthful Eating Throughout the Ages. *Culinary Nutrition*, 475–543. doi: <https://doi.org/10.1016/b978-0-12-391882-6.00011-x>
- Misra, N. N., Koubaa, M., Roohinejad, S., Juliano, P., Alpas, H., In cio, R. S. et al. (2017). Landmarks in the historical development of twenty first century food processing technologies. *Food Research International*, 97, 318–339. doi: <https://doi.org/10.1016/j.foodres.2017.05.001>
- Cherevko, A., Kiptelaya, L., Mikhaylov, V., Zagorulko, A., Zagorulko, A. (2015). Development of energy-efficient ir dryer for plant raw materials. *Eastern-European Journal of Enterprise Technologies*, 4 (8 (76)), 36–41. doi: <https://doi.org/10.15587/1729-4061.2015.47777>
- Pashniuk, L. O. (2012). Food industry of Ukraine: state, tendencies and perspectives of development. *Ekonomichnyi Chasopych - XXI*, 9-10, 60–63. Available at: <http://dspace.nbuv.gov.ua/bitstream/handle/123456789/48329/18-Pashniuk.pdf?sequence=1>
- Kiptelaya, L., Zagorulko, A., Zagorulko, A. (2015). Improvement of equipment for manufacture of vegetable convenience foods. *Eastern-European Journal of Enterprise Technologies*, 2 (10 (74)), 4–8. doi: <https://doi.org/10.15587/1729-4061.2015.39455>
- De Laurentiis, V., Corrado, S., Sala, S. (2018). Quantifying household waste of fresh fruit and vegetables in the EU. *Waste Management*, 77, 238–251. doi: <https://doi.org/10.1016/j.wasman.2018.04.001>
- Silveira, A. C. P. (2015). Thermodynamic and hydrodynamic characterization of the vacuum evaporation process during concentration of dairy products in a falling film evaporator. *Food and Nutrition. Agrocampus Ouest*. Available at: <https://theses.hal.science/tel-01342521>
- Crespí-Llorens, D., Vicente, P., Viedma, A. (2018). Experimental study of heat transfer to non-Newtonian fluids inside a scraped surface heat exchanger using a generalization method. *International Journal of Heat and Mass Transfer*, 118, 75–87. doi: <https://doi.org/10.1016/j.ijheatmasstransfer.2017.10.115>
- Zahorulko, A., Zagorulko, A., Fedak, N., Sabadash, S., Kazakov, D., Kolodnenko, V. (2019). Improving a vacuum-evaporator with enlarged heat exchange surface for making fruit and vegetable semi-finished products. *Eastern-European Journal of Enterprise Technologies*, 6 (11 (102)), 6–13. doi: <https://doi.org/10.15587/1729-4061.2019.178764>
- Zahorulko, A. M., Zahorulko, O. Ye. (2021). Pat. No. 149981 UA. Plivkopodibnyi rezystyvnyi elektronahrivach vpyrominiuvalnoho typu. No. u202102839; declared: 28.05.2021; published: 23.12.2021. Available at: <https://base.uipv.org/searchINV/search.php?action=viewdetails&IdClaim=279804>
- Chernenkova, A., Leonova, S., Nikiforova, T., Zagranichnaya, A., Chernenkov, E., Kalugina, O. et al. (2019). The Usage of Biologically Active Raw Materials in Confectionery Products Technology. *OnLine Journal of Biological Sciences*, 19 (1), 77–91. doi: <https://doi.org/10.3844/ojbsci.2019.77.91>
- Cherevko, O., Mikhaylov, V., Zahorulko, A., Zagorulko, A., Gordienko, I. (2021). Development of a thermal-radiation single-drum roll dryer for concentrated food stuff. *Eastern-European Journal of Enterprise Technologies*, 1 (11 (109)), 25–32. doi: <https://doi.org/10.15587/1729-4061.2021.224990>

16. Kulichenko, A. I., Mamchenko, T. V., Zhukova, S. A. (2014). Sovremennye tekhnologii proizvodstva konditerskikh izdeliy s primeneniem pischevykh volokon. *Molodoy ucheniy*, 4, 203–206.
17. Zahorulko, A., Zagorulko, A., Kasabova, K., Shmatchenko, N. (2020). Improvement of zefir production by addition of the developed blended fruit and vegetable paste into its recipe. *Eastern-European Journal of Enterprise Technologies*, 2 (11 (104)), 39–45. doi: <https://doi.org/10.15587/1729-4061.2020.185684>
18. Cappa, C., Lavelli, V., Mariotti, M. (2015). Fruit candies enriched with grape skin powders: physicochemical properties. *LWT - Food Science and Technology*, 62 (1), 569–575. doi: <https://doi.org/10.1016/j.lwt.2014.07.039>
19. Kasabova, K., Zagorulko, A., Zahorulko, A., Shmatchenko, N., Simakova, O., Goriainova, I. et al. (2021). Improving pastille manufacturing technology using the developed multicomponent fruit and berry paste. *Eastern-European Journal of Enterprise Technologies*, 3 (11 (111)), 49–56. doi: <https://doi.org/10.15587/1729-4061.2021.231730>
20. Zahorulko, A., Zagorulko, A., Kasabova, K., Liashenko, B., Postadzhiev, A., Sashnova, M. (2022). Improving a tempering machine for confectionery masses. *Eastern-European Journal of Enterprise Technologies*, 2 (11 (116)), 6–11. doi: <https://doi.org/10.15587/1729-4061.2022.254873>
21. Zahorulko, A., Zagorulko, A., Yancheva, M., Serik, M., Sabadash, S., Savchenko-Pererva, M. (2019). Development of the plant for low-temperature treatment of meat products using ir-radiation. *Eastern-European Journal of Enterprise Technologies*, 1 (11 (97)), 17–22. doi: <https://doi.org/10.15587/1729-4061.2019.154950>
22. Kozhevnikova, V. O. (2016). *Udoskonalennia tekhnolohiyi khlilibulochnykh vyrobiv z vykorystanniam likarskoi ta priano-aromatychnoi syrovyny*. Odessa: ONAKhT, 23.
23. Sorokina, S. V., Borzylko, M. V., Miachykov, O. V. (2009). Zbahachennia plavlenykh syriv roslynnymy komponentamy. *Vestnik Nats. tekhn. un-ta "KhPI": Khimiya, khimicheskaya tekhnologiya i ekologiya*, 22, 127–131. Available at: http://repository.kpi.kharkov.ua/bitstream/KhPI-Press/30716/1/vestnik_KhPI_2009_22_Sorokina_Zbahachennya.pdf
24. Zahorulko, A., Cherevko, O., Zagorulko, A., Yancheva, M., Budnyk, N., Nakonechna, Y. et al. (2021). Design of an apparatus for low-temperature processing of meat delicacies. *Eastern-European Journal of Enterprise Technologies*, 5 (11 (113)), 6–12. doi: <https://doi.org/10.15587/1729-4061.2021.240675>
25. Kasiyanchuk, V. D. (2013). Sukhyi produkt topinambura - efektyvnyi napivfabrykat dlia vyrobnytstva produktsiyi likuvalno-profilaktychnoho pryznachennia. *Halytskyi likarskyi visnyk*, 3, 103–104. Available at: http://nbuv.gov.ua/UJRN/glv_2014_21_3_41
26. Kostenko, E., Milyukin, M., Butenko, E., Rubaha, N. (2019). Studying of the properties of cranberry. *Scientific Works of National University of Food Technologies*, 25 (4), 174–187. doi: <https://doi.org/10.24263/2225-2924-2019-25-4-20>
27. Hrodzynskiy, A. M. (Ed.) (1992). *Likarski roslyny: Entsyklopedychnyi dovidnyk*. Kyiv: Vydavnytstvo «Ukrainska Entsyklopediya» im. M. P. Bazhana, *Ukrainskyi vyrobnycho-komertsiynnyi tsentr «Olimp»*, 544. Available at: <https://archive.org/details/grodzinsky1>
28. Williams, H., Lindstr m, A., Trischler, J., Wikstr m, F., Rowe, Z. (2020). Avoiding food becoming waste in households – The role of packaging in consumers' practices across different food categories. *Journal of Cleaner Production*, 265, 121775. doi: <https://doi.org/10.1016/j.jclepro.2020.121775>
29. Sashnova, M., Zahorulko, A., Savchenko, T., Gakhovich, S., Parkhomenko, I., Pankov, D. (2020). Improving the quality of the technological process of packaging shape formation based on the information structure of an automated system. *Eastern-European Journal of Enterprise Technologies*, 3 (2 (105)), 28–36. doi: <https://doi.org/10.15587/1729-4061.2020.205226>
30. Cherevko, A., Mayak, O., Kostenko, S., Sardarov, A. (2019). Experimental and simulation modeling of the heat exchanche process while boiling vegetable juice. *Prohresyvni tekhnika ta tekhnolohiyi kharchovykh vyrobnytstv restorannoho hospodarstva i torhivli*, 1 (29), 75–85. Available at: <https://repo.btu.kharkov.ua/handle/123456789/298>
31. Burkhatovna, A. A., Abelbaevich, B. T., Kulkeldieva, A. G., Rakhmedovna, Ch. E. (2015). *Primenenie innovatsionnykh tekhnologii v proizvodstve muchnykh konditerskikh izdeliy*. *Evraziyskiy Soyuz Uchenykh*, 11 (20). Available at: <https://cyberleninka.ru/article/n/primenenie-innovatsionnyh-tehnologii-v-proizvodstve-muchnykh-konditerskih-izdeliy>
32. Samokhvalova, O., Kasabova, K., Oliinyk, S. (2014). The influence of the enriching additives on the dough structure formation and baked muffins. *Eastern-European Journal of Enterprise Technologies*, 1 (10 (67)), 32–36. doi: <https://doi.org/10.15587/1729-4061.2014.20024>