

This paper reports a study into the holding capacity of tubular belt with partitions of a mixture of concrete and the effect of the technique of loading the tubular belt on increasing the pressure of the material on the partition. The task solved was the establishment of regularities in the process of transporting concrete with coarse aggregate and, on their basis, the determination of the structural and technological solution.

The studies have shown that the use of transverse partitions significantly increases the holding capacity of the load by a tubular belt and makes it possible to transport concrete with coarse filler.

It has been experimentally proved that when using the belt with transverse grooves Reef-1, the force of cargo on the partition is several times less than when using a smooth belt. The force of the load on the partition can be reduced if loading takes place on a horizontal or slightly inclined surface of the belt.

The properties of the load and the height of the layer of material loaded into the tubular belt significantly affect the force arising on the partition. With the height of the layer of material to be loaded, the force increases to a certain limit, which depends on the initial resistance to the shift of the material, after which it remains constant. Based on the results, plots of the dependence of the force on the partition on the angle of inclination of the belt and the weight of the material were constructed.

The operability based on specific initial (numerical) data of the derived theoretical dependences describing the efforts of the above-placed layers of material on the partition located in the tubular belt has been experimentally confirmed. The methodology of research and design of experimental benches for measuring the load on the partition of tubular belt conveyors was refined.

The results make it possible to consider the construction of a crane – a concrete dispenser equipped with a tubular belt conveyor with partitions for the construction of high-rise structures

Keywords: *tubular belt with partitions, holding capacity, concrete with coarse filler, force on the partition, technique of loading concrete on the conveyor*

UDC 621.807.212.7

DOI: 10.15587/1729-4061.2023.277758

ESTABLISHING REGULARITIES IN THE TRANSPORTATION OF CONCRETE WITH COARSE FILLER BY A TUBULAR BELT WITH PARTITIONS

Alexandr Gavryukov

Corresponding author

Doctor of Technical Sciences, Associate Professor*

E-mail: gavryukov@ukr.net

Andrii Tretiak

PhD, Associate Professor

Department of Automation,

Electronics and Telecommunications

National University

«Yuri Kondratyuk Poltava Polytechnic»

Pershotravnevyi ave., 24, Poltava, Ukraine, 36011

Andriy Zaprivoda

PhD, Head of Department*

Sergiy Inosov

PhD, Associate Professor*

*Department of Automation of

Technological Processes

Kyiv National University of

Construction and Architecture

Povitroflotskyi ave., 31, Kyiv, Ukraine, 03037

Received date 13.02.2023

Accepted date 17.04.2023

Published date 28.04.2023

How to Cite: Gavryukov, A., Tretiak, A., Zaprivoda, A., Inosov, S. (2023). Establishing regularities in the transportation of concrete with coarse filler by a tubular belt with partitions. *Eastern-European Journal of Enterprise Technologies*, 2 (1 (122)), 82–91. doi: <https://doi.org/10.15587/1729-4061.2023.277758>

1. Introduction

Belt conveyors are widely used in various industries to move various materials horizontally or at a slight angle. This is due to the simplicity of the design and high efficiency of the processes of moving materials to the required place. There are a large number of cases of moving various materials at significant angles to the horizon. It is impossible for conventional belt conveyors to move materials at angles when the lifting component exceeds the friction forces holding on the belt. In place of conventional belt conveyors, belt tubular conveyors are proposed [1–5]. Such conveyors can move materials not only at high angles but also be used for the spatial configuration of the track with bends in the horizontal and vertical planes at the same time. They can also be used to transport various materials in a mountain landscape, as well as with natural and artificial obstacles along the highway.

The peculiarity of the structure of these conveyors opens up the possibility of transporting cargo simultaneously on the upper (cargo) and lower branches of the conveyor. However, the effective improvement of methods for calculating tubular conveyors is constrained by the need for additional experimental studies into the holding capacity of the material with tubular belt with partitions and techniques for loading cargo during vertical transportation.

A possible application of a tubular conveyor with pneumatic partitions for vertical transportation of concrete with coarse filler is an urgent task in the construction of high-rise structures.

2. Literature review and problem statement

The use of tubular belt conveyors for transportation of man-made goods is considered in works [1, 2]. In particular,

paper [1] investigates steeply inclined tubular belt conveyors with incomplete filling of the belt with cargo.

In [3], a report of suppliers of tubular belt systems in the United States by German manufacturers ContiTech Conveyor Belt Group, Siemens AG Process Industries and Drives Division, and ThyssenKrupp Industrial Solutions is given. They have low-elongated, high-strength frames, and are claimed to provide efficient transportation of ore and overburdens along the slopes of the mine with inclination angles of 30–50°. Transportation of solid material in the range of 50–90° can be implemented using a skip conveyor but vertical transportation by tubular belt is out of the question. The companies explain that belts made of smooth pipes allow transporting bulk materials with inclination angles of up to 30°.

Work [4] reports research and development in the field of closed belt conveyors. The data relate to the transition section on the loading device from the unfolded belt to the tubular, the size of the overlapping zone of the sides of the belt. The cited paper is quite valuable but there are no studies concerning the vertical transportation of cargo by tubular belt with pneumatic partitions.

In work [5], it is indicated that the limiting angle of inclination of the belt conveyor with a tubular depends on the angle of internal friction of the transported cargo, which makes vertical transportation of concrete impossible.

In [6], a mathematical model is presented, which determines the contact forces arising in the tubular conveyor belt, thereby determining the required belt stiffness. The results of theoretical studies are consistent with experimental data obtained using a six-point stiffness device. The studies are performed for a steeply inclined conveyor with a not fully loaded belt. Vertical transportation is not considered.

Work [7] reports a study of loads on the rollers of the six-roller support of a tubular belt conveyor that cannot transport cargo vertically, especially concrete mix.

Transportation tubular belt conveyors are considered in [8, 9]. The papers consider the possibility of transporting cargo in two directions, by the upper and lower branches of the conveyor. The relevance of using tubular belt conveyors is emphasized. Steeply inclined transportation of cargo with a not fully loaded belt is considered, but it is not indicated how to transport the material vertically.

Work [10] reports an analysis of the development of tubular belt conveyors. The paper cites the scope of application of these conveyors. Nobody is talking about vertical transportation at all.

The retention of cargo in the pipe can be observed in the outlets of bunkers, the so-called arching [11].

In work [11], it is noted that there are two types of arching. The first type is the formation of arches of coarsely lumpy cargo when a random combination of large pieces of material in the process of outflow forms a stable arch above the hole. The second type is the formation of arches of finely fractional cargoes (granular and smaller), particles having connectivity.

The formation of vaults of finely fractional cargoes, particles having connectivity, most fully corresponds to the physical process of holding the cargo with a tubular belt.

In work [11], it is indicated that a stress state is created near the outlet, characterized by a stress oval.

If the vertical tangential force acting around the perimeter of the outlet is sufficient to perceive the mass of the load lying above the hole, then an arch is formed above the latter, the contours of which will coincide with the trajectories of the greatest main stress.

The condition of the equilibrium state of the load in the outlet of the hopper with a round hole depends on the diameter of the hole, the initial shear resistance, the volumetric weight, and the angle of internal friction of the bulk material. Analysis of theoretical dependences given in [11] provides an understanding of the holding capacity of the material by a tubular surface but does not solve the problem of possible transportation of cargo by a tubular belt.

In [12], on the basis of studies reported in [11], dependences were obtained to determine the equilibrium state of cargo in a tubular belt with its constant stay on a steeply inclined conveyor.

It is established that an increase in the friction forces of bulk cargo on the conveyor belt causes a decrease in the pressure of bulk cargo along the axis of the vertical conveyor, that is, there is some retaining section that ensures the equilibrium state of the load in the tubular belt. To determine the vertical pressure of bulk cargo on the layers lying below, the load and taking into account friction, on the conveyor belt, the authors obtained a differential equation of forces acting on the elementary volume of cargo [12]. The equation includes the pressure force of the above-placed layers of material on the elementary volume of bulk material, the pressure force of the weight of the elementary volume of bulk material on the lower layers of the material. Also included were the pressure force on the elementary volume of the material from below, the friction force of the elementary volume of bulk material on the inner surface of the belt, and the internal adhesion force in the elementary volume of bulk material. In [12], the possibility of transporting cargo by a tubular belt is considered but there is no evidence of the adequacy of theoretical dependences by experimental studies, there are no studies related to the use of corrugated belt and partitions.

In [13], the retention of cargo in a tubular belt by crimping the belt is considered.

The crimping force created by the roller supports and which does not depend on the length of the conveyor is indicated. The amount of crimping force ensures the retention of the load by the belt and depends on the material of the transported cargo, the diameter of the belt pipe, the installation angle, and the starting parameters of the conveyor [13]. Criticisms regarding work [12] can also be attributed to paper [13].

In work [14], the holding capacity of cargo by a tubular belt during vertical transportation is considered but the problem of how to transport concrete mix with coarse filler is not solved.

In [15], the possibility of transporting cargo with coarse filler is indicated, however, the problem is not solved about the pressure that the partition would perceive from the material.

Currently, the idea of using partitions interconnected by a rope to transport materials in a tube is used around the world [16]. However, in these conveyors the tubular part is stationary, and the material that is transported has certain limitations. If we add that there are significant friction forces of the material along the tubular part of the conveyor [16], then the transportation of cargo in a tubular belt with partitions [17] deserves more attention.

The main conclusions of work [18] indicate that the holding capacity of the tubular belt is limited by the diameter of the pipe, the characteristics of the transported material, the installation angle of the conveyor, and the mode of movement of the belt. In [18], the dependence on determining the specific pressure along the conveyor axis on the action of higher placed layers of material during start-up or changing the length of

transportation is given. For a vertical tubular conveyor, the specific pressure along the conveyor axis depends on the parameters of the opening (cross-section) of the belt pipe, the parameters of the transported material, the starting parameters, the height of the loaded material in the tubular belt.

The use of transverse pneumatic partitions significantly increases the holding capacity of the tubular conveyor belt [18]. The cited paper shows the dependence of the average force of the above-placed layers of material on the partition when starting or changing the length of transportation P_{part} of conveyor. The average force depends on the specific pressure along the conveyor axis and the opening (cross-section) area of the belt pipe.

In work [18], a structural diagram of a conveyor-crane is also given, in which the transported material is loaded directly into the lower vertical part of the tubular conveyor, which is mounted on the crane tower. Study [18] is closest to solving the tasks but there is no experimental confirmation of the results obtained theoretically.

The patent for utility model No. 1145580 «Crane – concrete dispenser» [17] shows a estimation scheme in which the material is loaded on the horizontal part of the conveyor, which then passes into a curvilinear-inclined and then into a vertical one. Analyzing the structural schemes given in [17, 18], it was found that without performing experimental studies it is impossible to say how to load material on the conveyor, namely on the horizontal, or in the lower vertical part of a tubular conveyor with partitions.

In [19], the calculation of parameters in the design of structures of a tubular belt conveyor is given, however, this applies only to a belt with a not fully load on its cross section.

In [20], the use of cargo transportation by a belt conveyor with partitions is considered but this applies only to inclined conveyors.

Works [21–23] consider modeling the interaction of a tubular conveyor belt with roller supports. It is investigated how roller supports affect the holding capacity of the material by the belt. The authors do not solve the problem associated with the vertical transportation of material with coarse filler.

The design of vertical conveyor systems with tubular belt is considered in work [24], however, as in [14], the task of how to transport concrete mix with coarse filler is not solved.

Our review of the literature [1–24] showed that to solve the problem of vertical transportation of concrete mix with coarse filler, it is necessary to conduct experimental studies in this area.

3. The aim and objectives of the study

The purpose of this work is to establish patterns in the process of transporting concrete with coarse filler. This will make it possible to determine the structural and technological solution for transporting concrete with coarse filler, for example, a crane-concrete dispenser.

To accomplish the aim, the following tasks have been set:

- to establish the influence of physical and mechanical properties of the concrete mix and the angle of inclination of the tubular belt on the amount of forces on the partition of the tubular belt with a corrugated and smooth surface when loading with a turn;
- to establish the nature of the force change on the transverse partition of the tubular belt with a corrugated and

smooth surface depending on the height of the column and the physicomaterial properties of the concrete mix during layer-by-layer loading;

- to check the efficiency with specific initial (numerical) data of the derived theoretical dependences to determine the pressure on the partition in a tubular belt with a corrugated and smooth surface experimentally.

4. The study materials and methods

The object of our study is the working process of holding a mixture of concrete by a tubular belt with partitions.

The main hypothesis of the study assumes that the construction of a vertical belt conveyor with partitions, which can transport concrete with coarse filler, is based on the use of corrugated belt and a horizontal or slightly inclined loading device.

Assumptions made in the study are the absence of starting parameters of the tubular belt conveyor.

The main parameters that must be considered during the experiment include:

- inner diameter of tubular belt;
- height or weight of the material above the partition;
- physical and mechanical characteristics of the loaded material;
- condition of the belt surface (smooth or grooved);
- angle of inclination of the belt;
- download technique.

The studies were conducted using the conveyor belt Reef-1, manufactured by the Lisichansk plant of rubber-technical articles (Ukraine); the technical characteristics are given in Table 1.

Table 1
Technical characteristics of the belt Reef-1

Parameter	Quantity
Width, mm	900
Polyamide fabric type	TK-400 GOST 18215-72
Strength limit of one belt laying, N/cm	at least 4000
Number of spacers, pcs	4
Calculated tensile strength of the belt, N	125568
Durability class of rubber covers	C
Thickness of the upper (working) lining, mm	8
Thickness of the lower (non-working) gasket, mm	2
The shape of the grooves	transverse grooves
Type of supporting fabric	Reef-1
Grooving depth, mm	6
Rounding radius of the bottom of the grooves, mm	6
Pitch of grooves, mm	15
The width of the comb above the grooves, mm	3
Total thickness, mm	20.5
Mass of 1 m ² , kg	24.8

As a research material, a concrete mixture with different cone subsidence was used. The choice of research material is dictated by the possibility of applying the results in practice.

To perform experimental studies, benches were designed and manufactured, with the help of which it is possible to solve

the tasks. Experimental and theoretical research methods were adopted taking into account those processes that can occur in a tubular conveyor with partitions.

Fig. 1 shows a bench for establishing the forces perceived by the partition of a vertical tubular belt during layer-by-layer loading.

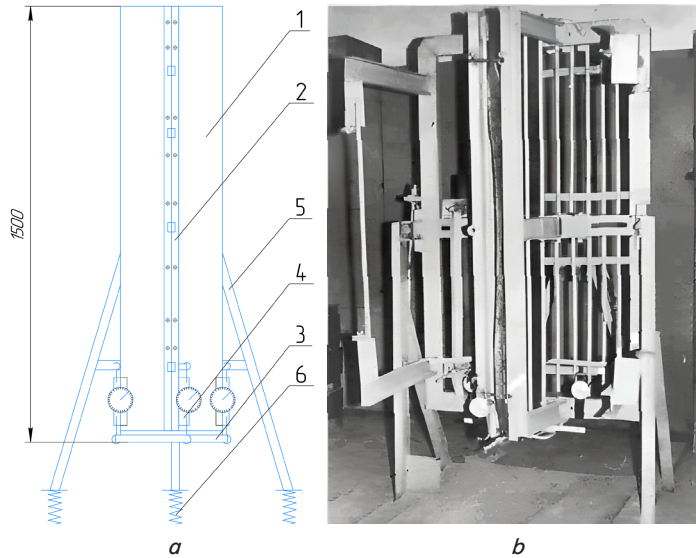

Fig. 1. Bench for establishing the forces perceived by the partition of a vertical tubular belt during layer-by-layer loading: *a* – structural diagram; *b* – general view

The bench for establishing the forces perceived by the partition of a vertical tubular belt during layer-by-layer loading (Fig. 1) consists of a transverse rolled belt (Reef-1) 1 with stiffeners 2. The bottom hole of the rolled belt is blocked by bottom 3. The bottom is suspended on dynamometers 4. The belt is mounted vertically on racks 5 with springs 6.

The design of the bench allows folding the belt with grooves inward or outward. In the first case, the corrugated surface of the belt is the working one, in the second – smooth.

By changing the width of the belt, you can get different pipe diameters.

Fig. 2 shows a bench for determining the forces perceived by the tubular belt partition when loading material on a horizontal or inclined section.

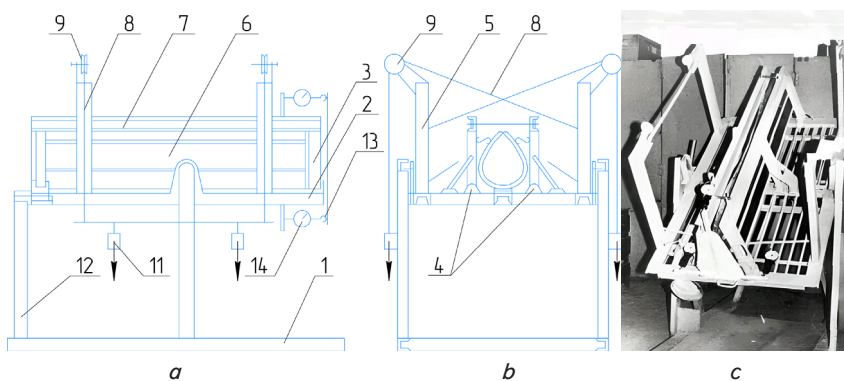

Fig. 2. Bench for determining the forces perceived by the tubular belt partition when loading material on a horizontal or inclined section: *a* – structural diagram (side view); *b* – structural diagram (front view); *c* – general view

The bench for determining the forces perceived by the tubular belt partition when loading material on a horizontal or inclined section (Fig. 2) consists of a fixed frame 1 on which a rotary frame 2 is installed. Swivel posts 3 with sliding hinged supports 4 are hinged on the swivel frame.

Longitudinal guides 5 are fixed on the swivel posts, on which belt 6 is located. The upper ends of the swivel posts are interconnected by bars 7, to which ropes 8 are fixed, passing through blocks 9. Rods 10 with balancing weights 11 are attached to the ends of the ropes.

The rotary frame is fixed in the horizontal plane with bracket 12. The end side of the belt is overlapped by bottom 13 suspended on dynamometers 14.

Raising and lowering swivel racks with guides is carried out by balancing loads.

When lifting the racks, the belt folds; when lowering, it straightens.

The belt is tilted by turning the frame.

Devices and equipment for operation:

- a standard cone for determining the mobility of a wet plastic mixture;
- a measuring capacity. Volume, 0.016 m³;
- a ruler. Length, 1000 mm; division unit, 1 mm;
- a cord. Length, 1000 mm;
- a false bottom;
- a dynamometer, pcs. – 3;
- dynamometer load, N: maximum – 250; minimum – 1.0; one division unit of the dynamometer, N – 0.2; the limit value of the scale – 250; slope error, % – 2;
- scales: weight of weighed cargo, kg; minimum, 0.25; maximum, 50; one division unit, 0.25; the limit value of the scale, 50; error of response, %, ±3;
- material to be weighed: crushed stone, sand, cement, concrete mix.

A procedure for carrying out work when determining loads perceived by the tubular belt partition:

1. A bench is installed on the test site.
2. The reduced diameter of the tubular belt is determined.
3. The volume of the mixture for the loading height of the tubular belt is determined.
4. The volume of the measuring capacity is determined.
5. A false bottom is installed and a partition is suspended on dynamometers. The false bottom is installed so that it tightly covers the bottom hole of the tubular belt and does not touch the partition.

6. The height of the layer loaded into the tubular belt of the material is calculated when loading it into the measuring capacity.

7. Preparation of a concrete mixture of the predefined mobility.

8. The mobility of the prepared mixture is determined by the results of three measurements.

9. The weight of the mixture placed in the measuring capacity is determined (the weight of the mixture is determined by the results of three weighings).

10. The bulk weight of the mixture is calculated.

11. The first portion of material is poured into the tubular belt with a measuring capacity.

12. The false bottom is removed and dynamometer readings are recorded.

13. The measuring capacity is used to perform a layer-by-layer loading of material in subsequent portions.

14. After loading each portion, dynamometer readings are recorded.

15. After the experiment, the settling of a standard cone of concrete mix used as a material of high humidity is re-determined.

16. Experiments on the determination of forces on the partition of a tubular belt with the predefined mobility of the mixture are carried out at least three times.

17. The arithmetic mean value of the force on the partition is determined.

18. The standard deviation of the parameter is determined.

19. The coefficient of variance is determined.

20. The probability of obtaining results according to the predefined probability is set.

21. The maximum acting force on the partition is determined under different loading techniques. With a layered technique (Fig. 1), the tubular belt is installed vertically. With a turn (Fig. 2), the tubular belt is installed obliquely. When determining the maximum acting force on the partition, the belt is loaded in a horizontal position, and the forces on the partition are recorded at different angles of inclination of the tubular belt.

22. According to the results of experiments, we plot the change of forces on the partition depending on the weight of the material being filled up and the angle of inclination of the belt.

5. The results of investigating the change in the force of concrete on the partition located in the tubular belt

5.1. The influence of the properties of concrete and the height of the column of material acting on the partition when loading with a turn

As a result of experimental studies, plots of force change, on the partition of smooth and corrugated tubular belt, depending on the angle of inclination of the pipe at different weights and humidity of the concrete mix when loading with a turn were constructed (Fig. 3, 4).

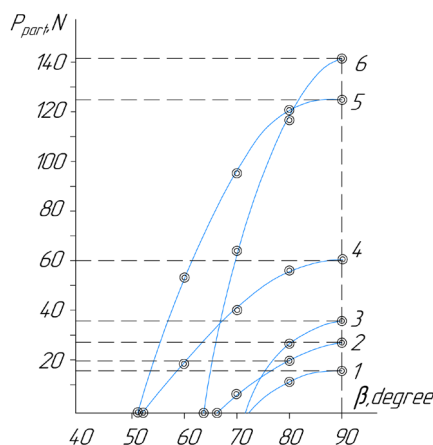

Fig. 3. Dependence of the force on the partition P_{part} depending on the angle of inclination of the belt when loading with a turn, concrete β with a cone settling of 1 cm for different loads and belt: 1 – 500 N, Reef-1; 2 – 800 N, Reef-1; 3 – 1200 N, Reef-1; 4 – 500 N, smooth; 5 – 800 N, smooth; 6 – 1200 N, smooth. The plot shows points obtained experimentally

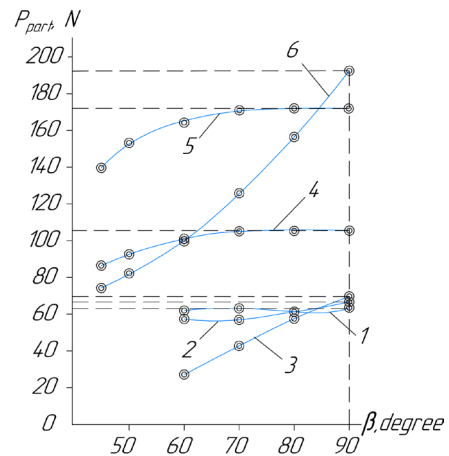

Fig. 4. Dependence of the force on the partition P_{part} depending on the angle of inclination of the belt when loading with a turn with concrete β with a cone settling of 10 cm for different loads and belt: 1 – 500 N, Reef-1; 2 – 800 N, Reef-1; 3 – 1200 N, Reef-1; 4 – 500 N, smooth; 5 – 800 N, smooth; 6 – 1200 N, smooth. The plot shows points obtained experimentally

As follows from Fig. 3, 4, the maximum force on a partition with a smooth belt is greater than on a partition with a corrugated belt. The force arising on the partition is much greater for a concrete mix having a higher humidity. The smaller the angle of inclination of the tubular belt, the less force on the partition.

5.2. Changes in the forces on the partition depending on the height of the column and the properties of concrete during layer-by-layer loading

As a result of our experimental studies, plots of the change of force on the partition of a smooth and corrugated tubular belt depending on the weight (height of the column) and physico-mechanical properties of the concrete mix during layer-by-layer loading were built (Fig. 5).

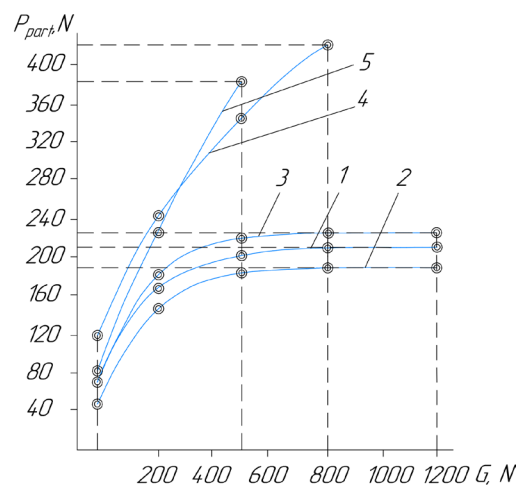

Fig. 5. Dependence of the force on the partition P_{part} depending on the weight of the concrete mix G (layer-by-layer loading) for different settlements of the cone and belt: 1 – 10 cm, Reef-1; 2 – 1 cm, Reef-1; 3 – 13 cm, Reef-1; 4 – 10 cm, smooth; 5 – 1 cm, smooth; 6 – 13 cm, smooth. The plot shows points obtained experimentally

As follows from Fig. 5, the force on the partition depending on the load in the tubular belt increases with increasing weight (layer height) to a certain limit, after which it remains constant.

Table 2 gives comparative data from experimental studies to determine the maximum forces on the partition of tubular belts under different loading techniques.

Table 2
The maximum force acting on the partition of a tubular belt with a diameter of 260 mm

Material	Weight of loaded material, N						Note
	500		800		1200		
	Belt surface						
	corrugated	smooth	corrugated	smooth	corrugated	smooth	
Concrete with cone settling of 1 cm	16	60	28	125	37	143	Loading by turning
	184	330	190	420	190	–	Layered loading
Concrete with cone settling of 10 cm	64	106	67	173	70	193	Loading by turning
	200	382	209	–	210	–	Layered loading

As follows from Table 2, the loading technique greatly affects the force transmitted to the partition.

Preferred loading is by turning. In this case, the force is transmitted to the partition 3–5 times less than with layer-by-layer loading.

5.3. Checking the operability of the derived theoretical dependences with specific initial (numerical) data to determine the pressure on the partition experimentally

Work [12] gives the dependence of the average force of the above-placed layers of material on the partition when starting or changing the length of transportation P_{part} of conveyor:

$$P_{part} = \omega \cdot \sigma = \frac{\omega(\gamma \cdot \omega \cdot (\sin \beta \pm j/g) - z \cdot \tau_0)}{k_b \cdot f \cdot z} \left(1 - e^{-\frac{hk_b \cdot f \cdot z}{\omega}} \right), \quad (1)$$

where ω is the opening area (cross sections) of the belt pipe, m^2 ; z – perimeter of the opening (cross sections) of the belt pipe, m ; j – belt acceleration during start-up or change of conveyor transportation length, m/s^2 ; g – gravitational acceleration, m/s^2 ; k_b – lateral pressure coefficient; σ – specific pressure along the conveyor axis from the action of higher placed layers of material, N/m^2 ; f – coefficient of internal friction of the material; γ – volumetric weight of bulk material, N/m^3 ; τ_0 – initial resistance to material shift, N/m^2 .

To verify the adequacy of the theoretical dependence obtained (1), we determine its components that occur during the experiment.

In the limiting case, when the coefficient of internal friction is equal to the coefficient of friction of the load against the belt, the lateral pressure coefficient acquires the value:

$$k_b = \frac{1}{1+2f^2}.$$

The initial resistance to shifting of bodies with high humidity is determined by the dependence to determine the maximum angle of slope of the material in the stack:

$$\beta_s = \frac{H_\Delta \cdot \gamma \cdot \sin \varphi_{fr}}{H_\Delta \cdot \gamma \cdot \cos \varphi_{fr} - 2 \cdot \tau_0 (1 + \sin \varphi_{fr})}, \quad (2)$$

where β_s is the limiting angle of slope (deg); γ – volumetric weight of material N/m^3 ; H_Δ – stack height, m ; φ_{fr} – angle of internal friction. Fig. 6 shows the settling scheme of a wet mixture for a standard cone.

In the above example, for the initial position $r_K=5$ cm; $R_K=10$ cm; $H_K=30$ cm; and $V_c=5500$ cm^3 .

When settling, the upper radius $A'C'$ decreases and changes along the curve $A'A''B$. Approximating this curve by the line $A'AB$, we get:

$$r'_K = \left(1 - \frac{\Delta h}{\Delta h_{M.O.}} \right) \cdot r_K, \quad (3)$$

where Δh is the settling of a standard cone; $\Delta h_{M.O.}$ – the minimum amount of settling at which the settled mixture acquires a conical shape.

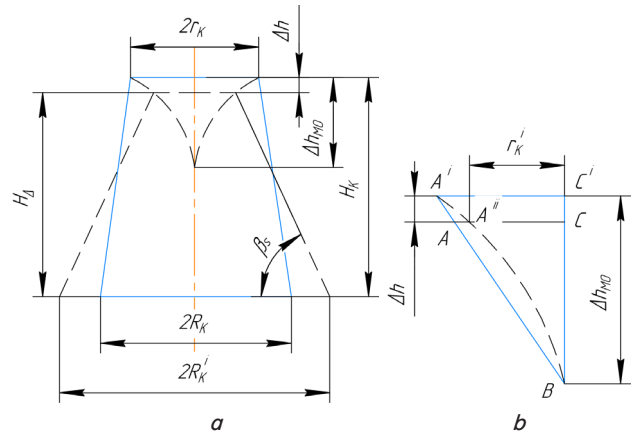

Fig. 6. The estimation scheme of changing the geometric parameters of the stack of concrete mix during settling: *a* – the maximum angle of the natural slope of a standard cone; *b* – upper radius of a standard cone

Radius of the lower base after settling:

$$R'_K = \left[\frac{3}{4\pi H_\Delta} (4V_A - \pi r_K^2 H_\Delta) \right]^{\frac{1}{2}} - \frac{r'_K}{2}, \quad (4)$$

where $H_\Delta = H_K - \Delta h$ is the height (stack) of the cone of concrete mix after settling, cm .

Substituting the values r'_K and H_Δ in the formula for determining R'_K , we get:

$$R'_K = \left\{ 3 \left[\frac{V_A}{\pi(H_K - \Delta h)} - \frac{r_K^2}{4} \left(1 - \frac{\Delta h}{h_{M.O.}} \right)^2 \right] \right\}^{\frac{1}{2}} - \frac{r_K}{2} \left(1 - \frac{\Delta h}{h_{M.O.}} \right), \quad (5)$$

or

$$R'_K = \left[\frac{5,252}{30 - \Delta h} - 18.75 \left(1 - \frac{\Delta h}{h_{M.O.}} \right)^2 \right]^{\frac{1}{2}} - 2.5 \left(1 - \frac{\Delta h}{h_{M.O.}} \right). \quad (6)$$

From Fig. 5, it follows that:

$$\beta_c = \frac{H_K - \Delta h}{R'_K - r'_K}. \tag{7}$$

Taking this into account and noticing that $\text{tg}\varphi_{fr} = f$, we get:

$$\tau_0 = \gamma \frac{(H_K - \Delta h) - f(R'_K - r'_K)}{2(f + \sqrt{1 + f^2})}, \tag{8}$$

or

$$\tau_0 = \gamma \cdot \frac{(H_K - \Delta h) - f \cdot \left[R'_K - \left(1 - \frac{\Delta h}{\Delta h_{M.O.}} \right) \cdot r_K \right]}{2 \cdot (f + \sqrt{1 + f^2})}. \tag{9}$$

Substituting instead of H_K and r_K their values, we find:

$$\tau_0 = \gamma \cdot \frac{(30 - \Delta h) - f \cdot \left[R'_K - \left(1 - \frac{\Delta h}{\Delta h_{M.O.}} \right) \cdot 5 \right]}{2 \cdot (f + \sqrt{1 + f^2})}. \tag{10}$$

If expressed in N/m^3 , then dependence (10) will take the form:

$$\tau_0 = \gamma \cdot \frac{(30 - \Delta h) - f \cdot \left[R'_K - \left(1 - \frac{\Delta h}{\Delta h_{M.O.}} \right) \cdot 5 \right]}{200 \cdot (f + \sqrt{1 + f^2})}. \tag{11}$$

Fig. 7 shows the plots of dependence $R'_K = f(\Delta h)$ at $h_{M.O.}$, varying from 10 to 30 cm.

According to dependence (8), at $\gamma = 22000 \text{ N/m}^3$; $f = 0,8$; $\Delta h_{M.O.} = 25 \text{ cm}$, $\Delta h = 5 \text{ cm}$, $R'_K = 12,5 \text{ cm}$, the initial resistance to displacement of the mixture is 980 N/m^2 .

Table 3 gives values of τ_0 for wet mixtures $\gamma = 22000 \text{ N/m}^3$ at $f = 0,8$ calculated at $\Delta h_{M.O.} = 25 \text{ cm}$ at different values of Δh .

The value of τ_0 and the internal coefficient of friction f at a known maximum force on the partition are determined on the basis of the results of experimental studies given in Table 2, with layer-by-layer loading and corrugated belt.

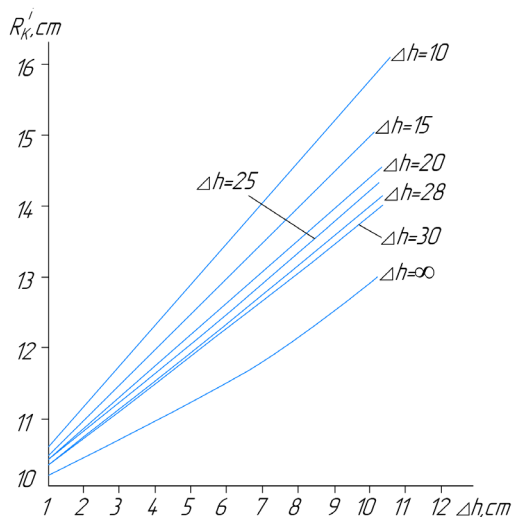

Fig. 7. Dependence of the radius of the lower base of a standard cone after settling R'_K on plasticity Δh

Table 3

Calculated values of the initial resistance of a wet mixture of different plasticity

$\Delta h, \text{ cm}$	1	4	5	6	7	8	9	10
$\tau_0, \text{ N/m}^2$	1,300	1,050	980	900	810	730	650	570

With a relatively large overlying layer of material on the partition, the component $\exp(-h \cdot k_b \cdot f \cdot z / \omega)$ can be neglected and equation (1) will take the form:

$$P_{part.max} = \frac{\omega [\gamma \cdot \omega (\sin \beta + j/g) - z \cdot \tau_0]}{k_b \cdot f \cdot z}. \tag{12}$$

If the coefficient of friction of the material against the walls is equal to the coefficient of internal friction of the transported material, then:

$$k_b = \frac{1}{1 + 2f^2}, \tag{13}$$

For a tubular belt:

$$P_{part.max} = \frac{\pi R_{fr}^2 (1 + 2f^2) [\gamma \cdot R_{fr} (\sin \beta + j/g) - 2 \cdot \tau_0]}{2f}. \tag{14}$$

After transforming dependence (14), we get:

$$\tau_0 = \frac{\gamma \cdot D_{fr} (\sin \beta + j/g)}{4} - \frac{4 \cdot P_{part.max} \cdot f}{\pi \cdot D_{fr}^2 \cdot (1 + 2f^2)}. \tag{15}$$

Since the cargo is transported vertically:

$$\tau_0 = \frac{\gamma \cdot D_{fr}}{4} - \frac{4 \cdot P_{part.max} \cdot f}{\pi \cdot D_{fr}^2 \cdot (1 + 2f^2)}. \tag{16}$$

Multiplying the right- and left-hand parts of equation (13) by f results in the following equation:

$$\Psi = k_b f = \frac{f}{1 + 2f^2}.$$

When $f = 0,7 \div 1,5$, the value of Ψ can be represented by a linear function:

$$\Psi = 0,425 - 0,101f, \tag{17}$$

then substituting equation (17) into equation (16) at $k_b = 0,4$ we obtain:

$$\tau_0 = 0,25\gamma D_{fr} - \frac{0,541 P_{part.max} (1 - 0,238f)}{D_{fr}^2},$$

or

$$\tau_0 = 0,25\gamma D_{fr} - \frac{0,13 P_{part.max} (4,21 - f)}{D_{fr}^2}. \tag{18}$$

When $f = 0,7 \div 1,5$, the $f + (1 + f^2)^{1/2} = \Psi'$ value can be determined from the following dependence:

$$\Psi' = 0,71 + 1,72f. \tag{19}$$

Substituting (19) in (11), we get:

$$\tau_0 = \frac{A - Bf}{0.71 + 1.72f}, \quad (20)$$

where

$$A = \frac{\gamma(30 - \Delta h)}{2 \cdot 10^2}, \quad (21)$$

$$B = \gamma \frac{10 + \Delta h \cdot R'_K - 5(1 - \Delta h / h_{M.O.})}{2 \cdot 10^2}. \quad (22)$$

Value of R'_K at $\Delta h_{M.O.} = 10 \div 30$ cm can be represented by dependence:

$$R'_K = 10 + \Delta h(1.703 - 0.0103h_{M.O.}). \quad (23)$$

Substituting (23) in (22), we have:

$$B = \gamma \frac{10 + \Delta h(1.703 - 0.0103h_{M.O.}) - 5(1 - \Delta h / h_{M.O.})}{2 \cdot 10^2}. \quad (24)$$

Solving equations (20) and (18) together, we get:

$$f^2 + f \left(4.46 \frac{Bd^2}{P_{part,max}} + 1.92 \frac{\gamma d^3}{P_{part,max}} - 3.67 \right) + \left(0.795 \frac{\gamma d^3}{P_{part,max}} - 4.46 \frac{Ad^2}{P_{part,max}} - 1.734 \right) = 0. \quad (25)$$

Denote:

$$a = 4.46 \frac{Bd^2}{P_{part,max}} + \frac{1.92\gamma D_{fr}^3}{P_{part,max}} - 3.67, \quad (26)$$

$$b = 0.795 \frac{\gamma D_{fr}^3}{P_{part,max}} - 4.46 \frac{AD_{fr}^2}{P_{part,max}} - 1.734. \quad (27)$$

Having solved equation (25) and performed the transformation, we have:

$$f = -\frac{a}{2} + \sqrt{\frac{a^2}{4} - b}. \quad (28)$$

For our experimental data (Table 2), the results of calculations are summarized in Table 4. The Table 4 shows the values for $D_{fr} = 0.26$ m; $\Delta h_{M.O.} = 25$ cm; $\gamma = 22600$ N/m³.

Converting the experimental value of the force parameter on partition P_{part} (Fig. 7) through the parameter of the height of the mixture h and putting the calculated experimental values of the initial shear resistance τ_0 and the coefficient of internal friction f to dependence(1), we compared the theoretical and experimental plots of changes in material pressure on the partition in a tubular belt (Fig. 8).

Calculated values of the initial shear resistance and internal coefficient of friction of the concrete mix

$P_{part,max}$, N	Δh , cm	A , N/m ²	B , N/m ²	a	b	f	τ_0 , N/m ²
210	10	2,260	2,425	5.203	-3.475	0.599	10.832
190	1	3,277	751	5.072	-5.272	0.885	254.258

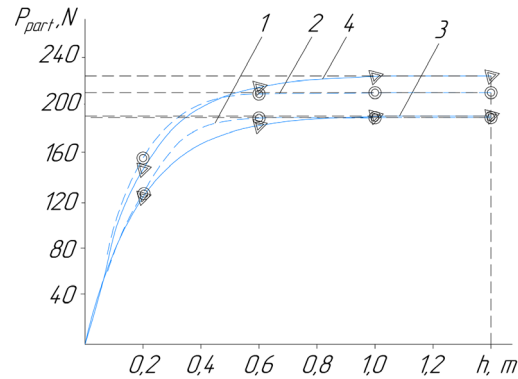

Fig. 8. Convergence plots of experimental and theoretical studies of the force on the partition P_{part} depending on the height of the concrete mixture h , loaded in a tubular corrugated belt with layer-by-layer loading:

- 1 – experimental (concrete with a cone settling of 1 cm);
- 2 – experimental (concrete with a cone settling of 10 cm);
- 3 – theoretical (concrete with a cone settling of 1 cm);
- 4 – theoretical (concrete with a cone settling of 10 cm).

A triangle is a point obtained theoretically, a circle is a point obtained experimentally

The discrepancy between theoretical and experimental results does not exceed 10 %, which is quite acceptable.

6. Discussion of results of the experimental study into the holding capacity of cargo by tubular belt partitions

A possible use of the crane-concrete dispenser makes it possible to obtain a continuous-action installation that transports concrete with coarse filler. During construction, the processes of shrinkage and creep of the mixture are minimized when pouring concrete with coarse filler.

Our studies are a continuation of previously performed theoretical research into the cargo holding capacity of a tubular belt with pneumatic partitions [18].

The design and application of fundamentally new benches (Fig. 1, 2) to determine the forces acting on the partition of a tubular belt when loading material have allowed us to perform experimental studies.

The changes in the maximum forces on the partition in a smooth and corrugated tubular belt depending on the mass (filling height of the pipe), the physical and mechanical properties of the material, the technique of filling the pipe were experimentally investigated. The initial resistance to shearing of the material, the coefficient of friction of the material against the belt, and the coefficient of internal friction of the material (concrete mix) essentially affect the amount of force arising on the partition (dependence (1), (Fig. 3–5)).

The maximum force on a partition with a smooth belt is greater than on a partition with corrugated belt. The force arising on the partition will be much greater when loading a concrete mix having a higher humidity (Table 2).

Table 4

The possibility of reducing the force on the partition when using a belt with a corrugated surface and a loading technique in which the material on the belt enters a horizontal or slightly inclined surface of the belt has been experimentally shown (Fig. 3, 4), (Table 2). The force on

the partition increases with decreasing of the following parameters: the initial resistance to material shift, the coefficient of material friction against the belt, and the coefficient of internal friction of the material. The force on the partition decreases with increasing the above parameters of the material.

The adequacy of the obtained theoretical dependences given in [18] is experimentally confirmed. The results related to the determination of the arising forces on the partition of a tubular belt can be used to design a tubular conveyor with partitions transporting concrete mix with coarse filler.

The proposed tubular conveyor with partitions is a continuous transport machine that makes it possible to increase the productivity of transporting concrete during the construction of high-rise structures due to the absence of unproductive technological operations, for example, as in a tower crane, lowering an empty bucket after unloading concrete at the destination. This is especially true in the construction of nuclear power plants where concrete mix with coarse filler is needed. Concrete pumps, which are also continuous transport machines, are not able to do this.

The productivity and height of transportation of a tubular conveyor with partitions is limited only by the strength of the belt and the rope on which the pneumatic partitions are mounted [17].

The energy intensity of transportation by the conveyor is associated with insignificant friction forces in the mechanisms of the conveyor, and the cargo branch of the conveyor balances the empty branch. Thus, energy costs are involved only in lifting the load.

The next stage of research may be the development and research of the mechanism for connecting and sealing the sides of the belt and pneumatic partitions.

Part of the research related to the use of corrugated belt can be used in the design of tubular conveyors without partitions.

Studies concerning the technique of loading tubular conveyors with partitions cannot be fully applied to tubular conveyors without partitions. To ensure the equilibrium state of the cargo in a tubular belt without partitions, some retaining section is needed. In other words, the material must be fed continuously on the belt. For a tubular conveyor with partitions, there are no such restrictions.

The performance limitation for a tubular conveyor with partitions may be the maximum sealing capacity of the mechanism for connecting the sides of the belt, which requires additional research.

7. Conclusions

1. The force on the partition from the load in the tubular smooth belt is greater than from the load in the tubular cor-

rugated belt. When using the belt with transverse grooves Reef-1, the force is several times less than when using a smooth belt. The amount of force from the load is essentially influenced by the physical and mechanical properties of the concrete mix, namely the initial resistance to material shifting, the coefficient of friction of the material against the belt, the coefficient of internal friction of the material (concrete mix), and the angle of inclination of the tubular belt. With a decrease in the angle of inclination of the tubular belt, the force transmitted by the load to the partition decreases from several times to tens of times, depending on the angle of rotation and humidity of the mixture.

2. The force on the partition of the load located in the tubular belt increases with increasing weight (layer height) of the material loaded to a certain limit, which depends on the initial resistance to the shift of the material, after which it remains constant. The force on the partition depends on the properties of the load in the tubular belt. With an increase in the settling of the concrete cone, the force on the partition increases. With layer-by-layer loading, an increase in the settling of the cone from 1 cm to 10 cm increases the force on the partition by 1.1 times. When loading with a turn, increasing the settling of the cone from 1 cm to 10 cm increases the force on the partition by 4–1.8 times for the corrugated belt and by 1.7–1.3 times for the smooth belt, depending on the weight of the load on the partition.

3. We have experimentally confirmed the operability, with specific initial (numerical) data, of the obtained theoretical dependences describing the arising forces on partitions located in a tubular belt. The discrepancy between theoretical and experimental results does not exceed 10%. The results could be used to design a tubular conveyor with partitions transporting concrete mix with coarse filler.

Conflicts of interest

The authors declare that they have no conflicts of interest in relation to the current study, including financial, personal, authorship, or any other, that could affect the study and the results reported in this paper.

Funding

The study was conducted without financial support.

Data availability

All data are available in the main text of the manuscript.

References

1. Loeffler, F. J. Pipe / Tube Conveyors – A Modern Method of Bulk Materials Transport. Available at: <http://ckit.co.za/secure/tech-focus/loeffler/loeffler.htm>
2. Davydov, S. Ya., Valiev, N. G., Filatov, M. S., Polezhaev, N. I., Kozhushko, G. G. (2017). The use of tubular belt conveyors for the industrial waste of enterprises. *News of the Ural State Mining University*, 4 (48), 72–76. doi: <https://doi.org/10.21440/2307-2091-2017-4-72-76>
3. German Industrial Groups Join to Develop Tubular Belt Conveyors (2015). *Engineering & Mining Journal*. Available at: <https://www.e-mj.com/departments/suppliers-report/german-industrial-groups-join-to-develop-tubular-belt-conveyors/>
4. Lodewijks, G. (2000). Research and Development in Closed Belt Conveyor Systems. *Bulk Solids Handling*, 20, 465–470.

5. Kiriia, R., Smirnov, A., Zhyhula, T., Zhelyazov, T. (2020). Determination of the limiting angle of inclination of tubular belt conveyor. *E3S Web of Conferences*, 168, 00047. doi: <https://doi.org/10.1051/e3sconf/202016800047>
6. Zamiralova, M. E., Lodewijks, G. (2016). Shape Stability of Pipe Belt Conveyors: From Throughability to Pipe-Ability. *FME Transactions*, 44, 263–271. Available at: https://www.mas.bg.ac.rs/_media/istrazivanje/fme/vol44/3/6_mzamiralova_et_al.pdf
7. Smirnov, A., Mishchenko, T. (2019). Determination of the loads on the rollers of the tubular belt conveyor. *E3S Web of Conferences*, 109, 00096. doi: <https://doi.org/10.1051/e3sconf/201910900096>
8. Davydov, S. Ya., Kashcheev, I. D., Sychev, S. N., Lyaptsev, S. A. (2010). Tubular belt conveyer with turnover of the return run of the belt. *Refractories and Industrial Ceramics*, 51 (4), 250–255. doi: <https://doi.org/10.1007/s11148-010-9299-0>
9. Funke, H., Hartmann, K., Lauhoff, H. (2000). Design and Operating Performance of a Long-Distance Belt Conveyor System with Horizontal Curves and Simultaneous Material Transport in the Upper and Lower Strands. *ZKG INTERNATIONAL*, 20 (1).
10. Jiotode, A. S., Raut, A. A. (2017). Advancement in Conveyor System: Pipe Conveyor. *IJSRD - International Journal for Scientific Research & Development*, 5 (09). Available at: https://www.academia.edu/35618118/Advancement_in_Conveyor_System_Pipe_Conveyor
11. Zenkov, R. L., Grinevich, G. P., Isaev, V. S. (1977). *Bunkernye ustroystva*. Moscow: Mashinostroenie, 223.
12. Perten, Yu. A. (1977). *Krutonaklonnye konveyery*. Leningrad: «Mashinostroenie», 216.
13. Chernenko, V. D. (1985). *Teoriya i raschet krutonaklonnykh konveyerov*. Leningrad: Izd-vo Leningr. un-ta, 292.
14. Gavryukov, A. V., Penchuk, V. A., Korol'kov, B. A., Gololobov, B. D. (2004). Uderzhivayuschaya sposobnost' trubchatoy lenty pri vertikal'nom transportirovanii nasypnykh gruzov. *Visnyk Donbaskoi derzhavnoi akademii budivnytstva i arkhitektury*, 5 (47), 71–77.
15. Gavryukov, A. V., Penchuk, V. A., Korol'kov, B. A., Lutsko, T. V. (2007). Opredelenie parametrov pereborok trubchatogo konveyera pri transportirovanii gruzov. *Stroitel'stvo, materialoveden'e, mashinostroenie*, 39, 61–65.
16. Cable, Disc & Tube Conveyor Uses. Available at: <https://cablevey.com/tube-conveyor-uses/>
17. Havriukov, O. V., Klon, A. M., Tretiak, A. V., Kuznetsov, M. M., Morisenkov, Yu. P., Hololobov, B. D. (2016). Pat. No. 114580 UA. Kran – betonorozdavach. No. u201609957; declared: 29.09.2016; published: 10.03.2017, Bul. No. 5. Available at: <https://base.uipv.org/searchINV/search.php?action=viewdetails&IdClaim=233265>
18. Gavryukov, A., Shabaev, O. (2011). Retention of goods by tubular tape of conveyor operating with varying length. *Vseukrainskyi nauko-tekhnichniy zhurnal hirnychoho profilu*, 2 (30), 192–207. Available at: http://ea.donntu.edu.ua:8080/jspui/bitstream/123456789/22356/1/%d0%a8%d0%b0%d0%b1%d0%b0%d0%b5%d0%b2_%20%d0%93%d0%b0%d0%b2%d1%80%d1%8e%d0%ba%d0%be%d0%b2.pdf
19. Zhang, Z., Zhou, F., Ji, J. (2008). Parameters Calculation and Structure Design of Pipe Belt Conveyor. 2008 9th International Conference on Computer-Aided Industrial Design and Conceptual Design. doi: <https://doi.org/10.1109/caiced.2008.4730642>
20. Sheshko, E., Kutenkov, A. (2001). Substantiation of parameters high angle conveyor with boards and partitions at large productivity in open cast mines. 3rd International Symposium «MINING AND ENVIRONMENTAL PROTECTION». Beograd.
21. Fedorko, G., Ivanjov, V., Molnára, V. et al. (2012). Simulation of interaction of a pipe conveyor belt with moulding rolls. *Procedia Engineering*, 48, 129–134. doi: <https://doi.org/10.1016/j.proeng.2012.09.495>
22. Hötte, S., Overmeyer, L., Wennekamp, T. (2011). Form force behaviour of pipe conveyors in different curve radii. *Bulk Solids Handling*, 31 (3), 164–169.
23. Kiriia, R., Mishchenko, T. (2019). Determination of the maximum allowable distance between the roller conveyors of a tubular belt conveyor. *E3S Web of Conferences*, 109, 00035. doi: <https://doi.org/10.1051/e3sconf/201910900035>
24. Wesemeier, M. (1999). Projektierung von Schlauchgurt Senkrecht förderanlagen. In: *Fachtagung Schüttgutförderertechnik 99*.