

The 5G communication system requires an antenna as a receiving device that has high performance including wide bandwidth and high gain. Microstrip antennas have advantages such as low cost, suitable for high frequencies and easy to integrate with other devices. One of the disadvantages of microstrip antennas is their narrow bandwidth and low gain. Therefore, microstrip antennas with wide bandwidth and high gain are especially needed to support 5G communication systems. This paper provides a solution by proposed a wide bandwidth and high gain microstrip antenna operating at a resonant frequency of 3.5 GHz for a 5G communication system. The proposed antenna was developed in four stages starting from a single element, a two-element series array, a 4-element series array and a 4×2-element planar series array. A series planar array technique is proposed to increase the gain and bandwidth of the microstrip antenna simultaneously. In this paper, simulations and measurements from the proposed antenna are displayed and compared comprehensively to show the performance improvement from each stage of the development of the proposed model. Based on the measurement results, the designed antenna has an impedance bandwidth (IBW) of 0.6 GHz and fractional bandwidth (FBW) of 17.14 % with a frequency range of 3.11–3.71 GHz and maximum gain of 12.2 dB at a resonant frequency of 3.5 GHz. The bandwidth and gain of the antennas increased by 205 % and 99.03 % compared to single element antennas, respectively. Therefore, the proposed antenna can be recommended to be used as a receiving antenna for 5G communication systems

Keywords: antenna, microstrip, planar, series, array, bandwidth, gain, 5G, communication system, high frequencies

UDC 629

DOI: 10.15587/1729-4061.2023.285395

WIDE BAND AND HIGH GAIN MICROSTRIP ANTENNA USING PLANAR SERIES ARRAY 4×2 ELEMENT FOR 5G COMMUNICATION SYSTEM

Syah Alam

Corresponding Author

Master of Electrical Engineering, Associate Professor, Lecture*

*Department of Electrical Engineering

Universitas Trisakti

Kyai Tapa str., 1, DKI Jakarta, Indonesia, 11440

E-mail: syah.alam@trisakti.ac.id

Indra Surjati

Doctor of Electrical Engineering, Professor, Lecture*

Lydia Sari

Doctor of Electrical Engineering, Associate Professor, Lecture*

Yuli Kurnia Ningsih

Doctor of Electrical Engineering, Associate Professor, Lecture*

Suryadi

Bachelor of Electrical Engineering, Associate Professor, Lecture*

Galang Trihantoro

Bachelor of Electrical Engineering, Associate Professor, Lecture*

Teguh Firmansyah

Doctor of Electrical Engineering, Lecturer

Department of Electrical Engineering

Universitas Sultan Ageng Tirtayasa

Raya Palka str., Banten, Indonesia, 42117

Zahriladha Zakaria

Doctor of Electrical Engineering, Professor

Faculty of Electronic Engineering and Computer Engineering (FKEKK)

Universiti Teknikal Malaysia Melaka

Hang Tuah Jaya, Durian Tunggal, Melaka, Malaysia, 76100

Received date 09.06.2023

Accepted date 18.08.2023

Published date 30.08.2023

How to Cite: Alam, S., Surjati, I., Sari, L., Ningsih, Y. K., Suryadi, Trihantoro, G., Firmansyah, T., Zakaria, Z. (2023). Wide band and high gain microstrip antenna using planar series array 4×2 element for 5G communication system. *Eastern-European Journal of Enterprise Technologies*, 4 (5 (124)), 16–24. doi: <https://doi.org/10.15587/1729-4061.2023.285395>

1. Introduction

The 5G communication system offers high data rates and low latency, so it requires wide bandwidth [1]. Based on [2], the resonant frequency of the 5G communication system is divided into three classifications: high band, middle band and low band. One of the recommended frequencies for 5G communication systems is 3.5 GHz which is included in the middle band category [3]. Furthermore, to support the communication system between transmitter and receiver, antennas with high performance are needed. The key parameters to show the performance of the antenna are reflec-

tion coefficient, bandwidth, gain and radiation pattern [4]. One of the antennas that has been developed for wireless communication systems is the microstrip antenna because it has the advantages of compact dimensions, low cost and has the ability to operate at high frequencies [5, 6]. However, microstrip antennas have limitations including narrow bandwidth, low gain, and low directivity [7]. Furthermore, to support the communication system between transmitter and receiver, antennas with high performance are needed. The key parameters to show the performance of the antenna are reflection coefficient, bandwidth, gain and radiation pattern [8]. Therefore, antennas with wide bandwidth and high

gain are needed to support wireless communication systems such as Wi-Fi, 4G and 5G.

2. Literature review and problem statement

One of the antennas that has been developed for wireless communication systems is the microstrip antenna because it has the advantages of compact dimensions, low cost and has the ability to operate at high frequencies [9, 10]. However, microstrip antennas have limitations including narrow bandwidth, low gain and directivity [11]. Several previous studies have described and proposed microstrip antennas for 5G communication systems using several techniques including fractal, array and parasitic [12–14]. Previous studies presented by [15] have described microstrip antennas with wide bandwidth by adding parasitic elements that are placed above to the radiating elements. However, the gain of the antenna is still low, so it needs to be increased. Another study by [16] proposed a microstrip antenna configured in an array with four elements operating at a resonant frequency of 3.5 GHz with a bandwidth of 0.7 GHz and a gain of 9.24 dB. However, the increase in bandwidth is not in line with the gain so that when the bandwidth increases, the gain will decrease.

Therefore, a method and stages of development are needed to produce an antenna that has wide bandwidth and high gain simultaneously. Therefore, new methods and model development are needed to produce antennas that have wide bandwidth and high gain simultaneously. Generally, the addition of elements from antennas with a parallel configuration will increase the gain, but on the other hand the bandwidth becomes narrower. This is due to the mutual inductance between the elements of the antenna. For this reason, series arrays can be used as a solution to reduce mutual inductance between elements so that the gain and bandwidth can increase simultaneously.

3. The aim and objectives of the study

The aim of the study is to produce a compact microstrip antenna for 5G communication system.

To achieve this aim, the following objectives are accomplished:

- to simulation of characteristics of the antenna;
- to enhance bandwidth of microstrip antenna ≥ 200 MHz;
- to enhance gain of microstrip antenna ≥ 10 dB.

4. Materials and methods

4.1. Development model of proposed antenna

In this paper, the proposed antenna is developed based on four stages starting from a single element, a series array with 2 elements, a series array with 4 elements and the final stage is a series planar array with 4×2 elements. The model and development stages of the proposed antenna are shown in Fig. 1.

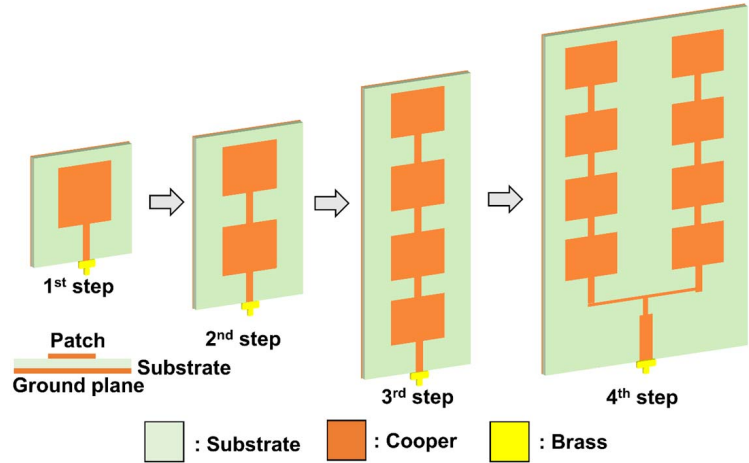

Fig. 1. Development model of proposed antenna

Fig. 1 shows a single element microstrip antenna with a rectangular shape where the patch antenna is on the top layer of the substrate which functions as a radiating element while the bottom layer functions as a ground plane as 1st step. The substrate used was FR-4 with a dielectric constant of 4.3, a loss tan of 0.0265 and a thickness of 1.6 mm. The proposed antenna is connected directly with the RP-SMA connector with an impedance of 50 Ω. In the 2nd and 3rd step, single element antennas are configured in series arrays with two and four elements. It should be noted, the dimensions of the patch antennas are identical whereas the microstrip lines are used to control the impedance and reflection coefficient of the proposed antenna. Furthermore, the 4th step model shows that the antenna is developed with a series planar array with 4×2 elements. It should be noted, the distance between radiating elements in a series planar array structure will greatly affect the bandwidth and gain of the antenna.

4.2. Design of single element microstrip antenna

Basically, the dimensions of a microstrip antenna are greatly influenced by the type of substrate and the resonant frequency used. In this paper, microstrip antennas are developed based on a rectangular shape where the length of the patch is represented as L while the width is represented as W . Furthermore, the dimensions of W and L can be determined based on following equation as follows:

$$W = \frac{c}{2f_o \sqrt{\frac{\epsilon_r}{2}}}, \quad (1)$$

$$L = L_{eff} - \Delta_L, \quad (2)$$

$$L_{eff} = \frac{c}{2f_o \sqrt{\epsilon_{eff}}}, \quad (3)$$

$$\epsilon_{eff} = \frac{\epsilon_r + 1}{2} + \frac{\epsilon_r - 1}{2} \left[1 + 12 \frac{h}{W} \right]^{-1}, \quad (4)$$

$$\Delta_L = 0.412 \frac{(\epsilon_{reff} + 0.3) \left(\frac{W}{h} + 0.264 \right)}{(\epsilon_{reff} - 0.258) \left(\frac{W}{h} + 0.8 \right)}, \quad (5)$$

where W and L represent the length and width of the patch, f_0 represents the resonance frequency, ϵ_r represents the permittivity of the substrate, ϵ_{eff} represents the effective permittivity of the substrate at a certain resonance frequency, h represents the thickness of the substrate while Δ_L represents the edge effect of the fringing field of the patch.

Furthermore, microstrip lines are proposed to control the impedance and reflection coefficient of the antenna. The dimensions of the microstrip line are greatly influenced by the input impedance and the resonant frequency used. In this paper, the input impedance used is 50 ohms. The dimensions of the microstrip line can be determined using the following equation:

$$W_z = \frac{2h}{\pi} \left\{ B - 1 - \ln(2B - 1) + \frac{\epsilon_r - 1}{2\epsilon_r} \left[\ln(B - 1) + 0.39 - \frac{0.61}{\epsilon_r} \right] \right\}, \quad (6)$$

$$B = \frac{60\pi^2}{Z_0 \sqrt{\epsilon_{eff}}}, \quad (7)$$

where W_z is the width of the microstrip line, Z_0 is the impedance of the antenna and B is the impedance constant. The impedance of the antenna is 50 Ω in line with the impedance of the connector used. Furthermore, the length of the microstrip line (L_z) is $\frac{1}{4}$ lambda (λ_g) which is determined by the following equation:

$$L_z = \frac{1}{4} \lambda_g, \quad (8)$$

$$\lambda_g = \frac{\lambda}{\epsilon_{eff}}. \quad (9)$$

The structure and design of the single element microstrip antenna with a rectangular shape is shown in Fig. 2.

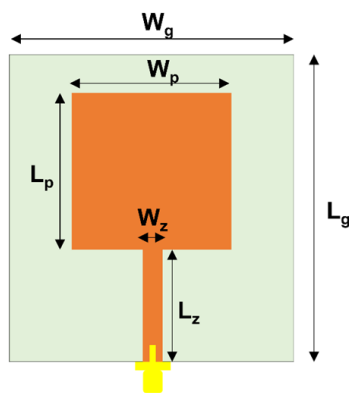

Fig. 2. Design of single element microstrip antenna

Fig. 2 describes the structure of a single element microstrip antenna where the antenna is connected to the connector using a transmission line with an impedance of 50 Ohms. The dimensions of the antenna are obtained using equations (1) to equations (5) while the dimensions of the transmission line are obtained using equations (6) and equations (7). Moreover, the overall dimensions of the single element microstrip antenna are shown in Table 1.

Table 1

Dimension of single element microstrip antenna

Parameter	Dimension (mm)
W_g	40
L_g	40
W_z	3
L_z	12.7
W_p	25
L_p	20

The antenna is designed and simulated using electromagnetic (EM) simulation with the Finite element method (FEM) based on HFSS 15.0. Parameters observed were reflection coefficient, VSWR and gain of the designed antenna. The simulation results of a single element microstrip antenna are shown in Fig. 3.

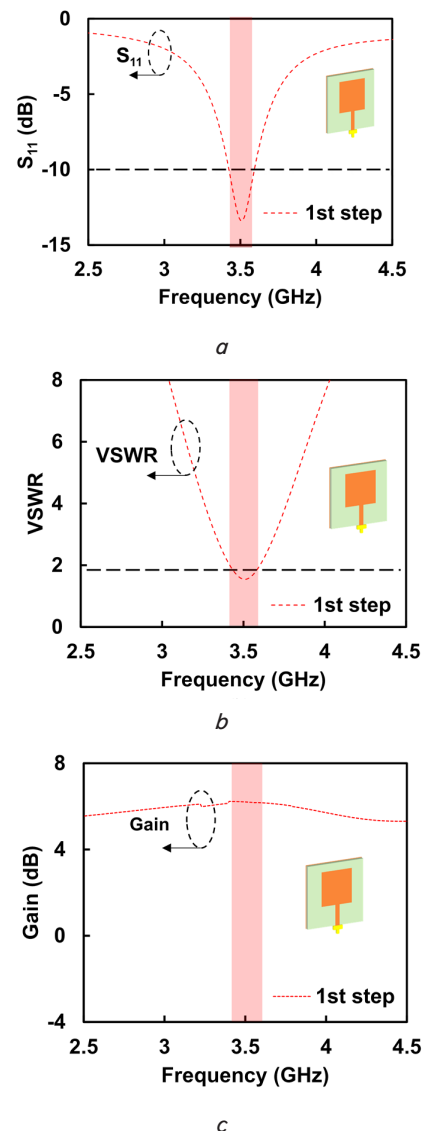

Fig. 3. Simulation result of single element microstrip antenna: a – S_{11} ; b – VSWR; c – Gain

Fig. 3, a shows that the single element microstrip antenna has been operating at a resonant frequency of 3.5 GHz

with a reflection coefficient (S_{11}) -13.39 dB. Moreover, the proposed antenna has VSWR of 1.54 and a gain of 6.2 dB as shown in Fig. 3, *b, c*. Furthermore, the impedance bandwidth (IBW) of the single element microstrip antenna is 0.2 GHz with a frequency range of 3.42–3.62 GHz. These findings indicate that the bandwidth obtained is narrow, so it needs further optimization.

4.3. Design of series array microstrip antenna with two and four elements

At this stage, the antenna is developed using a series array configuration with two elements. The dimensions of the patch and transmission line antennas are identical for a single element. The target of adding a patch in a series array configuration is to increase the gain of the antenna. Fig. 4 shows the design of a microstrip antenna with a series array configuration with two elements.

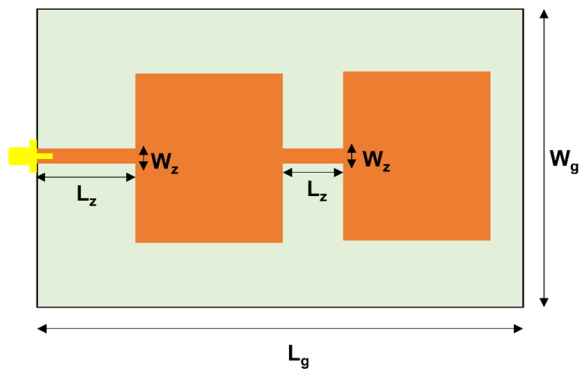

Fig. 4. Design of series array microstrip antenna with two elements

Fig. 4 shows that the two patch antennas are connected using a transmission line with $L_z=12.7$ mm in series and arranged in a vertical configuration. The dimensions of W_g and L_g are 40 mm and 75 mm, respectively. Furthermore, the simulation results of a microstrip antenna configured in series array with two elements are shown in Fig. 5.

Fig. 5, *c* shows that the implementation of a series array with two elements produces a high gain antenna characteristic with a gain of 8.37 dB at a resonant frequency of 3.5 GHz. However, the impedance bandwidth of the antenna is still narrow where the antenna operates at two different resonance frequencies of 3.15 GHz and 3.61 GHz with $S_{11} \leq -10$ dB and $VSWR \leq 2$ as shown in Fig. 5, *a, b*. Therefore, it is necessary to do further optimization so that the bandwidth of the antenna increases. It should be noted, the impedance bandwidth is observed from $S_{11} \leq -10$ dB and $VSWR \leq 2$. Furthermore, the proposed antenna is optimized using a series array with four elements as shown in Fig. 6 with W_g of 42 mm and L_g of 142 mm, while the simulation results are shown in Fig. 7.

Fig. 7, *a, b* shows that the impedance bandwidth of the antenna increases after being configured using a series array with 4 elements. The proposed antenna has an impedance bandwidth of 0.44 GHz with a frequency range of 3.11–3.55 GHz. In addition, the gain of the antenna also increases to 9.09 dB at a resonant

frequency of 3.5 GHz as shown in Fig. 7, *c*. These findings indicate that the addition of the number of elements greatly affects the bandwidth and gain of the antenna. Furthermore, the bandwidth and gain of the antenna will be optimized using a series planar array configuration with 4x2 elements.

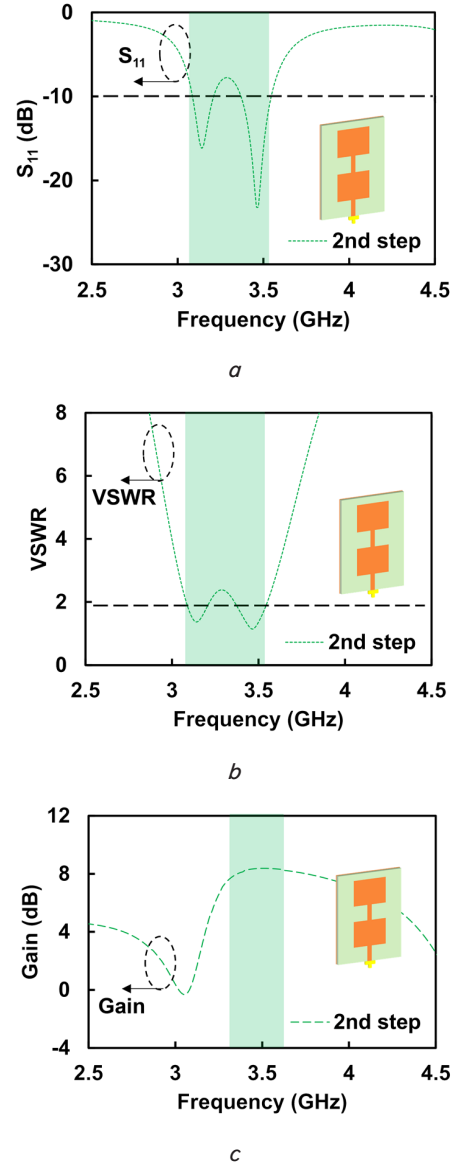

Fig. 5. Simulation result series array microstrip antenna with two elements: *a* – S_{11} ; *b* – VSWR; *c* – Gain

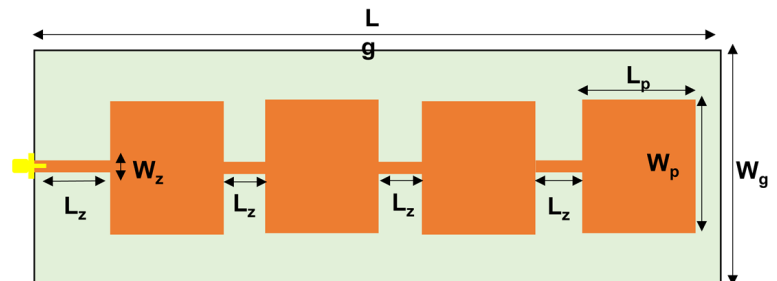

Fig. 6. Design of series array microstrip antenna with four elements

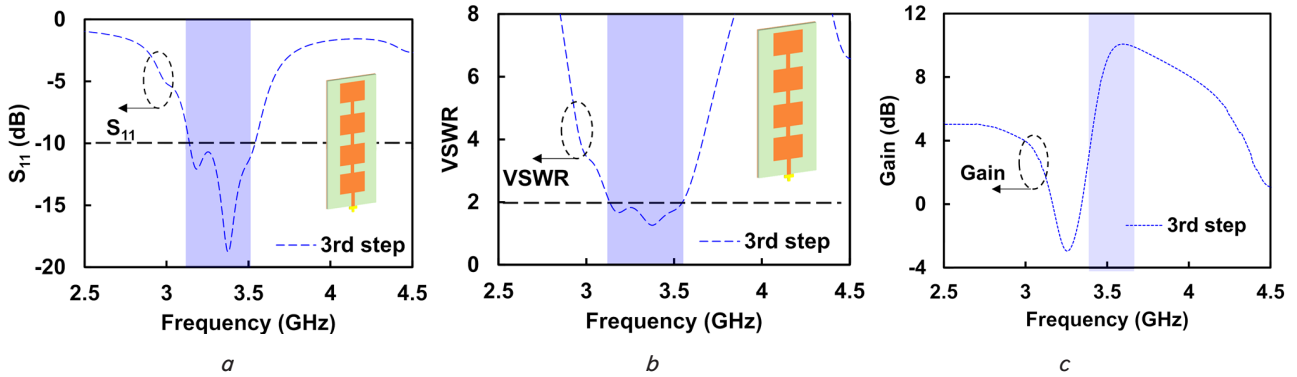

Fig. 7. Simulation result series array microstrip antenna with four elements: *a* – S_{11} ; *b* – VSWR; *c* – Gain

4. 4. Design of planar series array microstrip antenna with 4x2 elements

At this stage, the antenna with the series array is configured as a vertical planar separated by a distance represented by d_a . The distance between elements (d_a) is determined by the following equation:

$$d_a = \frac{1}{4}\lambda, \tag{9}$$

$$\lambda = \frac{c}{f}, \tag{10}$$

where d_a represents the gap between the elements of the array, λ represents the electrical length of the antenna and c is the speed of light (3×10^8 m/s). The design and model of the series planar array antenna with 4x2 elements is shown in Fig. 8.

Fig. 8 shows that the series array configuration antenna with four elements each connected planar using a transmission line with a step impedance of 50 Ohm (Z_0), 70.7 Ohm (Z_s) and 100 ohm (Z_L) which functions as impedance matching to control the reflection coefficient and VSWR of antenna. The width of the transmission line determines its impedance while the impedance of the transmission line can be determined based on the following equation:

$$Z_s = \sqrt{Z_0 \cdot Z_L}. \tag{11}$$

Furthermore, the overall dimensions of the series planar array antenna with 4x2 elements are shown in Table 2.

The overall simulation results of a series planar array antenna with 4x2 elements are shown in Fig. 9.

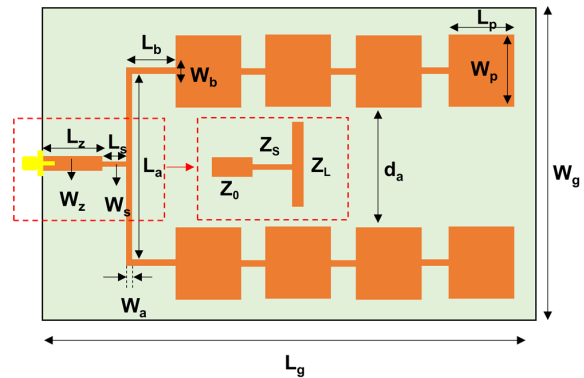

Fig. 8. Design of series planar array microstrip antenna with 4x2 element

Table 2

Dimension of series planar array antenna with 4x2 elements

Parameter	Dimension (mm)
W_g	130
L_g	187
W_z	3
L_z	40
W_p	25
L_p	20
W_s	1
L_s	3
W_a	2
L_a	94
W_b	3
L_b	12.7

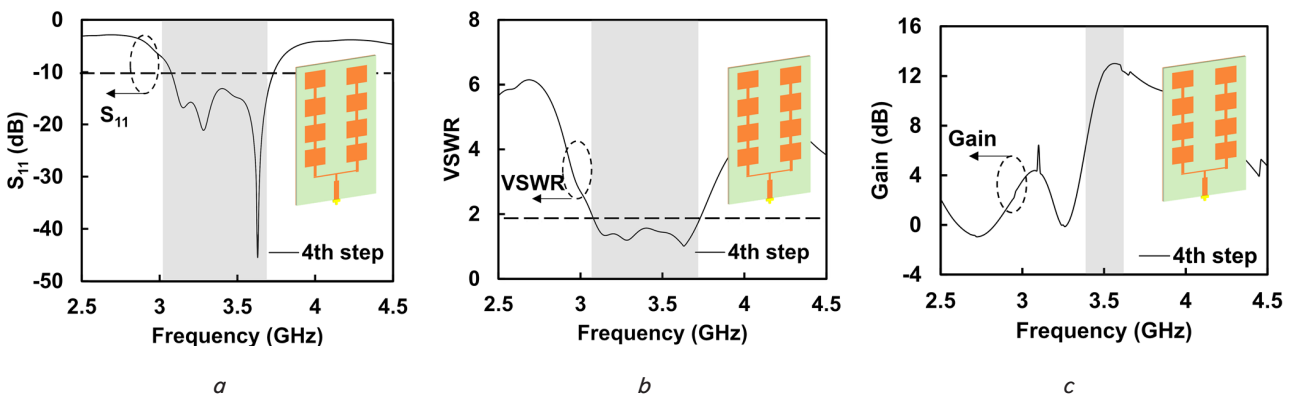

Fig. 9. Simulation result of series planar array microstrip antenna with 4x2 elements: *a* – S_{11} ; *b* – VSWR; *c* – Gain

Fig. 9 shows the bandwidth and gain of the antenna significantly increased after being configured with a series planar array with 4×2 elements. The impedance bandwidth of the antenna is 0.61 GHz with a frequency range of 3.1–3.71 GHz as shown in Fig. 9, *a, b* while the gain increases to 12.34 dB at a resonant frequency of 3.5 GHz as shown in Fig. 9, *c*. These findings indicate that the performance of the antenna increases significantly after being developed with a series planar array configuration with 4×2 elements.

5. Results of development compact microstrip antenna for 5G communication system

5.1. Simulation of characteristics of the antenna

The model development of the proposed antenna has been described and simulated in the previous section. Furthermore, the performance of the antenna development is observed by comparing the impedance bandwidth and gain. A comparison of the simulation results for each stage is shown in Fig. 10.

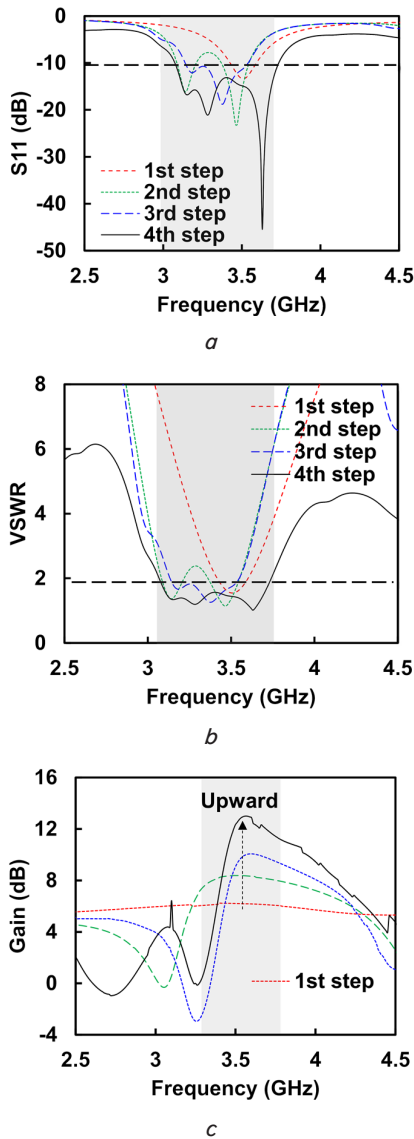

Fig. 10. Comparison of simulation result from development model of proposed microstrip antenna: *a* – S_{11} ; *b* – VSWR; *c* – Gain

Fig. 10, *a, b* show that the bandwidth impedance of the antenna increases significantly after being configured with a series planar array. At the 1st step, the bandwidth of the antenna is 0.2 GHz which increases to 0.44 GHz and 0.62 GHz at the 3rd and 4th steps, respectively. Furthermore, the gain of the antenna at the resonant frequency of 3.5 GHz also increases gradually where the 1st step gain is 6.2 dB, the 2nd step is 8.37 dB while the 3rd step and 4th step are 9.09 dB and 12.34 dB, respectively. In other words, the bandwidth and gain of the proposed antenna increase by 205 % and 99.03 % compared to the single-element microstrip antenna. These findings indicate that the gain and bandwidth of the proposed antenna increase simultaneously.

Based on Fig. 10, *a, b*, the bandwidth performance of the antenna at the 1st step, 2nd step, 3rd step and 4th step are shown in Table 3.

Table 3

Bandwidth of proposed antenna based on development model

Step	Range of frequency (GHz)	Bandwidth (GHz)
1 st step	3.42–3.62	0.20
2 nd step	3.38–3.54	0.16
3 rd step	3.11–3.55	0.44
4 th step	3.10–3.70	0.60

Based on Table 3, the bandwidth of the antenna increases at the 3rd and 4th step. However, at the 2nd step, the bandwidth of the antenna is narrower and has dual band characteristics as shown in Fig. 5, *a, b*. Furthermore, the performance comparison of the proposed antenna is determined based on the following equation:

$$BW = \frac{(Optimized\ BW - Initial\ BW)}{Initial\ BW} \times 100\ \% . \quad (12)$$

5.2. Bandwidth performance of proposed antenna

Furthermore, the antenna was fabricated using FR-4 substrate with a dielectric constant (ϵ_r) of 4.3, a loss tan ($\tan \delta$) of 0.0265 and a thickness (*h*) of 1.6 mm. The proposed antenna is connected to the RP-SMA connector with an impedance of 50 Ω as shown in Fig. 11, *b*. The measurement setup of the antenna is shown in Fig. 11, *a* where the proposed antenna is connected to port 1 of the Vector Network Analyzer (VNA). The frequency range used in the measurement process is 2.5–4.5 GHz with a sweep frequency of 0.01 GHz and an ambient temperature of 25 °C. Moreover, the simulation and measurement results are comprehensively compared to observe the performance of the fabricated antenna. Comparison results of the simulation and measurement processes of the proposed antenna are shown in Fig. 12.

Fig. 12 shows that the fabricated antenna has performance and characteristics that are in line with the simulation process. The impedance bandwidth (IBW) of the antenna with $S_{11} \leq -10$ dB and $VSWR \leq 2$ from the measurement process is 0.6 GHz with a frequency range of 3.11–3.71 GHz. The proposed antenna has wide bandwidth characteristics and meets the criteria and specifications for a 5G communication system where the required bandwidth is 200 MHz.

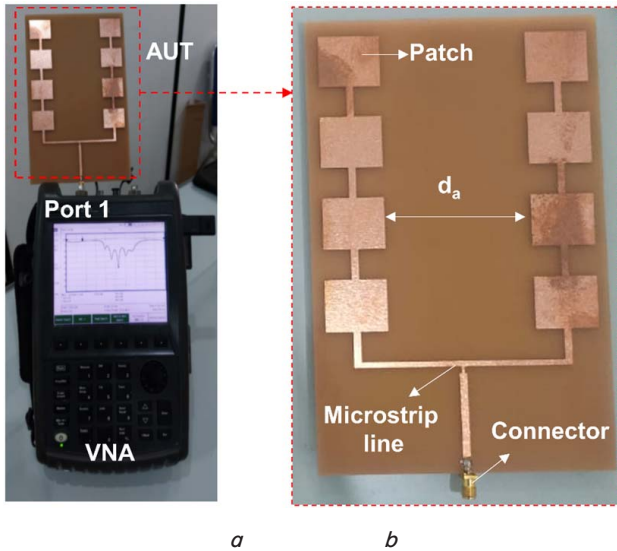

Fig. 11. Measurement process of proposed antenna: a – measurement setup for near-field parameter; b – fabrication of proposed antenna

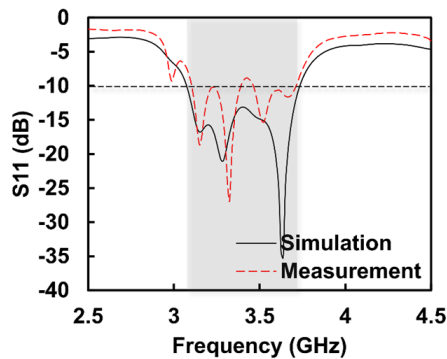

Fig. 12. Comparison between simulation and measurement of reflection coefficient of proposed antenna

The bandwidth of the single element antenna represents the initial bandwidth while the optimization bandwidth is obtained from the 2nd, 3rd and 4th steps. Based on equation (12), the bandwidth of the single element antenna increases 102 % and 205 % at the 3rd and 4th steps respectively. Furthermore, the performance is also observed in terms of increasing the gain of the antenna. Based on Fig. 10, c, the gain performance of the antenna at the 1st step, 2nd step, 3rd step and 4th step is shown in Table 3.

Table 4

Gain of proposed antenna based on development model

Step	Resonant frequency (GHz)	Gain (dB)
1 st step	3.5	6.20
2 nd step	3.5	8.20
3 rd step	3.5	9.09
4 th step	3.5	12.34

Based on Table 4, the gain of the proposed antenna increases gradually from the 1st, 2nd, 3rd and 4th steps in line with the increase in the number of elements of the antenna. Furthermore, the performance comparison of the proposed antenna is determined based on the following equation:

$$BW = \frac{(Optimized\ Gain - Initial\ Gain)}{Initial\ BW} \times 100\ \% . \quad (13)$$

5. 3. The gain of microstrip antenna

Furthermore, the gain and radiation pattern of the proposed antenna are observed by measuring in the anechoic chamber as shown in Fig. 13 where the designed antenna is positioned as a receiver (Rx) and a comparison antenna is used as a transmitter (Tx) separated by a distance $d=60$ cm and connected to port 1 and port 2 of the VNA using a coaxial cable.

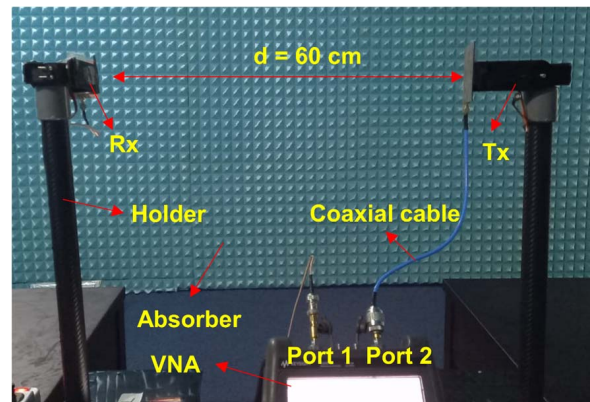

Fig. 13. Measurement setup for far-field parameter in anechoic chamber

Fig. 14, a, b shows the radiation pattern from the measurement results in line with the simulation results with a resonant frequency of 3.5 GHz with gain of 12.5 dB. These findings confirm that the proposed antenna has a high gain ≥ 10 dB with a directional radiation pattern at a resonant frequency of 3.5 GHz.

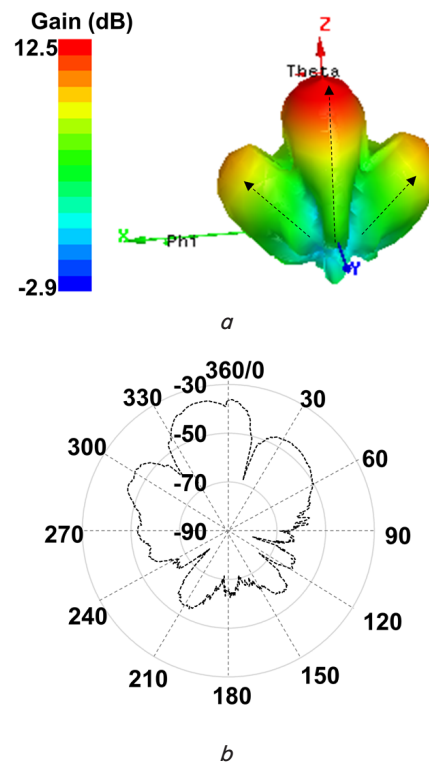

Fig. 14. Far field of proposed antenna: a – simulation result; b – measurement result

6. Discussion of experimental result of proposed antenna

The gain of the single element antenna represents the initial gain while the optimization gain is obtained from the 2nd, 3rd and 4th steps. Based on equation (13), the bandwidth of the single element antenna increases 32.25 %, 45.48 % and 99.03 % at the 2nd, 3rd and 4th steps respectively. In addition, the results presented in Fig. 12, 13 show that the antenna has a bandwidth and gain performance that is in line between the simulation and measurement. This indicates that the antenna has met a predetermined target.

Overall, this paper has comprehensively described and investigated the development of microstrip antennas with wide bandwidth and high gain. The antenna was developed in four steps including single element antenna, series array with two elements, series array with four elements and planar series array with 4x2 elements. The bandwidth and gain of the antenna were successfully increased based on the proposed steps. From the measurement results, the series planar array antenna with 4x2 elements has succeeded in increasing the performance in terms of bandwidth and gain up to 205 % and 99.03 % compared to single element antennas. Moreover, the proposed antenna has a wide bandwidth of 0.6 GHz and a directional radiation pattern with a high gain of 12.34 dB at a resonant frequency of 3.5 GHz. Furthermore, the planar series array method succeeded in increasing the gain and bandwidth simultaneously. The bandwidth of the antenna has met the target ≥ 200 MHz with a gain ≥ 10 dB.

However, there are several limitations, including the dimensions of the antenna which are still quite large and only operate at one resonant frequency. Therefore, the future work of this research is to reduce the dimensions of the antenna and optimize the antenna to work at several resonant frequencies so that it can be used for other communication systems such as 4G, Zigbee and Wi-Fi.

7. Conclusions

1. The bandwidth and gain of the proposed antenna is improved simultaneously through four stages including single elements, series arrays with 2x1 elements, series arrays with 4x1 elements and the final stage uses planar series arrays with 4x2 elements.

2. Bandwidth impedance of the proposed antenna is 0.6 GHz and successfully increased up to 205 % compared to single element antenna.

3. Gain of the proposed antenna is 12.5 dB and successfully increased up to 99.03 % compared to single element antenna.

Conflict of Interest

The authors declare that they have no conflict of interest in relation to this research, whether financial, personal, authorship or otherwise, that could affect the research and its results presented in this paper.

Financing

This work is supported by Research Institute of Universitas Trisakti and Indonesian Ministry of Research, Technology and Higher Education 2023 through a competitive research grant under the Fundamental Research Scheme, contract number 1440/LL3/AL.04/2023 and 708/A/LPPM/USAKTI/VII/2023.

Data availability

Manuscript has no associated data.

References

- Hobbs, S. (2018). Valuing 5G Spectrum: Valuing the 3.5 GHz and C-Band Frequency Range. Coleago Consulting.
- Hikmaturokhman, A., Ramli, K., Suryanegara, M. (2018). Spectrum Considerations for 5G in Indonesia. 2018 International Conference on ICT for Rural Development (IC-ICTRuDev). doi: <https://doi.org/10.1109/icitr.2018.8706874>
- Höyhtyä, M., Apilo, O., Lasanen, M. (2018). Review of Latest Advances in 3GPP Standardization: D2D Communication in 5G Systems and Its Energy Consumption Models. *Future Internet*, 10 (1), 3. doi: <https://doi.org/10.3390/fi10010003>
- Zhang, G., Basit, A., Khan, M. I., Daraz, A., Saqib, N., Zubir, F. (2023). Multi Frequency Controllable In-BandSuppressions in a Broad Bandwidth Microstrip Filter Design for 5G Wi-Fi and Satellite Communication Systems Utilizing a Quad-Mode Stub-Loaded Resonator. *Micromachines*, 14 (4), 866. doi: <https://doi.org/10.3390/mi14040866>
- Tawfeeq, N. N. (2017). Size Reduction and Gain Enhancement of a Microstrip Antenna using Partially Defected Ground Structure and Circular/Cross Slots. *International Journal of Electrical and Computer Engineering (IJECE)*, 7 (2), 894. doi: <https://doi.org/10.11591/ijece.v7i2.pp894-898>
- Surjati, I., Alam, S., Karnadi, J. (2019). Design of spiral labyrinth microstrip antenna for DVB-T application. *TELKOMNIKA (Telecommunication Computing Electronics and Control)*, 17 (1), 76. doi: <https://doi.org/10.12928/telkomnika.v17i1.11628>
- Sandi, E., Rusmono, R., Diamah, A., Vinda, K. (2020). Ultra-wideband Microstrip Array Antenna for 5G Millimeter-wave Applications. *Journal of Communications*, 15 (2), 198–204. doi: <https://doi.org/10.12720/jcm.15.2.198-204>
- Liu, J., Liu, H., Dou, X., Tang, Y., Zhang, C., Wang, L. et al. (2021). A Low Profile, Dual-Band, Dual-Polarized Patch Antenna With Antenna-Filter Functions and Its Application in MIMO Systems. *IEEE Access*, 9, 101164–101171. doi: <https://doi.org/10.1109/access.2021.3096969>
- Ullah, S., Yeo, W.-H., Kim, H., Yoo, H. (2020). Development of 60-GHz millimeter wave, electromagnetic bandgap ground planes for multiple-input multiple-output antenna applications. *Scientific Reports*, 10 (1). doi: <https://doi.org/10.1038/s41598-020-65622-9>
- Naga Jyothi Sree, G., Nelaturi, S. (2021). Design and experimental verification of fractal based MIMO antenna for lower sub 6-GHz 5G applications. *AEU - International Journal of Electronics and Communications*, 137, 153797. doi: <https://doi.org/10.1016/j.aeue.2021.153797>

References

1. Hobbs, S. (2018). Valuing 5G Spectrum: Valuing the 3.5 GHz and C-Band Frequency Range. Coleago Consulting.
2. Hikmaturokhman, A., Ramli, K., Suryanegara, M. (2018). Spectrum Considerations for 5G in Indonesia. 2018 International Conference on ICT for Rural Development (IC-ICTRuDev). doi: <https://doi.org/10.1109/icitr.2018.8706874>
3. Höyhtyä, M., Apilo, O., Lasanen, M. (2018). Review of Latest Advances in 3GPP Standardization: D2D Communication in 5G Systems and Its Energy Consumption Models. *Future Internet*, 10 (1), 3. doi: <https://doi.org/10.3390/fi10010003>
4. Zhang, G., Basit, A., Khan, M. I., Daraz, A., Saqib, N., Zubir, F. (2023). Multi Frequency Controllable In-Band Suppressions in a Broad Bandwidth Microstrip Filter Design for 5G Wi-Fi and Satellite Communication Systems Utilizing a Quad-Mode Stub-Loaded Resonator. *Micromachines*, 14 (4), 866. doi: <https://doi.org/10.3390/mi14040866>
5. Tawfeeq, N. N. (2017). Size Reduction and Gain Enhancement of a Microstrip Antenna using Partially Defected Ground Structure and Circular/Cross Slots. *International Journal of Electrical and Computer Engineering (IJECE)*, 7 (2), 894. doi: <https://doi.org/10.11591/ijece.v7i2.pp894-898>
6. Surjati, I., Alam, S., Karnadi, J. (2019). Design of spiral labyrinth microstrip antenna for DVB-T application. *TELKOMNIKA (Telecommunication Computing Electronics and Control)*, 17 (1), 76. doi: <https://doi.org/10.12928/telkomnika.v17i1.11628>
7. Sandi, E., Rusmono, R., Diamah, A., Vinda, K. (2020). Ultra-wideband Microstrip Array Antenna for 5G Millimeter-wave Applications. *Journal of Communications*, 15 (2), 198–204. doi: <https://doi.org/10.12720/jcm.15.2.198-204>
8. Liu, J., Liu, H., Dou, X., Tang, Y., Zhang, C., Wang, L. et al. (2021). A Low Profile, Dual-Band, Dual-Polarized Patch Antenna With Antenna-Filter Functions and Its Application in MIMO Systems. *IEEE Access*, 9, 101164–101171. doi: <https://doi.org/10.1109/access.2021.3096969>
9. Ullah, S., Yeo, W.-H., Kim, H., Yoo, H. (2020). Development of 60-GHz millimeter wave, electromagnetic bandgap ground planes for multiple-input multiple-output antenna applications. *Scientific Reports*, 10 (1). doi: <https://doi.org/10.1038/s41598-020-65622-9>
10. Naga Jyothi Sree, G., Nelaturi, S. (2021). Design and experimental verification of fractal based MIMO antenna for lower sub 6-GHz 5G applications. *AEU - International Journal of Electronics and Communications*, 137, 153797. doi: <https://doi.org/10.1016/j.aeue.2021.153797>
11. Tarpara, N. M., Rathwa, R. R., Kotak, N. A. (2018). Design of Slotted Microstrip patch Antenna for 5G Application. *International Research Journal of Engineering and Technology (IRJET)*, 05 (04). URL: https://www.academia.edu/37016852/Design_of_Slotted_Microstrip_patch_Antenna_for_5G_Application
12. Ali, H., Singh, P., Kumar, S., Goel, T. (2017). A Minkowski fractal ultrawide band antenna for 5G applications. 2017 IEEE International Conference on Antenna Innovations & Modern Technologies for Ground, Aircraft and Satellite Applications (IAIM). doi: <https://doi.org/10.1109/iaim.2017.8402541>
13. Hu, W., Liu, X., Gao, S., Wen, L.-H., Qian, L., Feng, T. et al. (2019). Dual-Band Ten-Element MIMO Array Based on Dual-Mode IFAs for 5G Terminal Applications. *IEEE Access*, 7, 178476–178485. doi: <https://doi.org/10.1109/access.2019.2958745>
14. An, W., Li, Y., Fu, H., Ma, J., Chen, W., Feng, B. (2018). Low-Profile and Wideband Microstrip Antenna With Stable Gain for 5G Wireless Applications. *IEEE Antennas and Wireless Propagation Letters*, 17 (4), 621–624. doi: <https://doi.org/10.1109/lawp.2018.2806369>
15. Cai, Q., Li, Y., Zhang, X., Shen, W. (2019). Wideband MIMO Antenna Array Covering 3.3–7.1 GHz for 5G Metal-Rimmed Smartphone Applications. *IEEE Access*, 7, 142070–142084. doi: <https://doi.org/10.1109/access.2019.2944681>
16. Alam, S., Surjati, I., Sari, L., Hilyawan, M. R., Zakaria, Z., Shairi, N. A. et al. (2022). Triple Band Notched Microstrip Antenna Using Planar Series 2x2 Element Arrayfor 5G Communication System. *Journal of Nano- and Electronic Physics*, 14 (1), 01019-1-01019–5. doi: [https://doi.org/10.21272/jnep.14\(1\).01019](https://doi.org/10.21272/jnep.14(1).01019)