

The object of this study is the process of thickening organic polycomponent compositions based on Jerusalem artichoke, apples, pumpkin, cranberry, and dogwood to produce high-level semi-finished products employing the proposed equipment and technological solutions implemented in a unified reactor. Conventional thickening devices have a steam heat supply system, which leads to overheating of certain layers of raw materials and prevents the mobile properties of the apparatus under the conditions of significant execution of organic properties of raw materials. The introduction of apratur-technological solutions could provide the competitive advantage of the reactors by heating the film-like emitting electric heater using a mixing device with a heating surface. Increasing the total area of heat exchange to 1.24 m² (prototype – 0.98 m²). There is a decrease in specific heat consumption by 20 %, specific metal capacity by 47 %, and the duration of the process by 30 %. We have determined rheological properties in the thickening of the organic polycomponent composition of the paste at a temperature of 55 °C and a shift rate within 3.0...4.5 s⁻¹, effective viscosity is in the range of 22...3.5 Pa·s. In this case, the kinetics of boiling in an improved reactor are by 27 % smaller than that in the basic structure R-P-150 m. According to organoleptic indicators, the composition "B" has a pleasant harmonious taste of all components. The results of the studies are relevant for practical implementation in the temperature range from 35 °C to 55 °C. The hardware and technological solutions form the competitiveness of mobile reactors for the thickening of plant semi-finished products under conditions of elimination of the steam component and an increase in the surface of the heat exchange of the mixing device. Providing preference in operating duration with the simultaneous use of Peltier elements to convert secondary heat to the autonomous work of exhaust fans in the motor compartment

Keywords: thickening reactor, mixing mechanism, increase in heat exchange surface, polycomponent nature

IMPROVING THE REACTOR FOR THICKENING ORGANIC PLANT-BASED POLYCOMPONENT SEMI-FINISHED PRODUCTS WITH HIGH DEGREE OF READINESS

Andrii Zahorulko

Corresponding author

PhD, Associate Professor*

E-mail: zagorulko.andrey.nikolaevich@gmail.com

Aleksey Zagorulko

PhD, Associate Professor*

Lyudmila Chuiko

PhD, Head of Research Department

Research Department**

Alla Solomon

PhD, Associate Professor

Department of Food Technologies and Microbiology

Vinnitsia National Agrarian University

Soniachna str., 3, Vinnitsa, Ukraine, 21008

Larysa Sushko

Senior Lecturer

Department of Higher Mathematics, Physics and General Engineering Disciplines***

Yuliia Tesliuk

PhD, Senior Lecturer

Department of Economics***

Lesia Kriuchko

PhD, Associate Professor

Department of Marketing***

Anastasiia Dunaienko

Department of Tractors and Agricultural Machines***

Serhii Andrukh

PhD, Senior Lecturer

Department of Architecture and Engineering Surveying

Sumy National Agrarian University

Herasyma Kondratieva str., 160, Sumy, Ukraine, 40021

Nataliia Tytarenko*

*Department of Equipment and Engineering of Processing and Food Industries**

**State Biotechnological University

Alchevskykh str., 44, Kharkiv, Ukraine, 61002

***Dnipro State Agrarian and Economic University

Serhiya Yefremova str., 25, Dnipro, Ukraine, 49600

Received date 09.10.2023

How to Cite: Zahorulko, A., Zagorulko, A., Chuiko, L., Solomon, A., Sushko, L., Tesliuk, Y., Kriuchko, L., Dunaienko, A., Andrukh, S.,

Accepted date 12.12.2023

Tytarenko, N. (2023). Improving the reactor for thickening organic plant-based polycomponent semi-finished products with high degree of readi-

Published date 28.12.2023

ness. *Eastern-European Journal of Enterprise Technologies*, 6 (11 (126)), 103–111. doi: <https://doi.org/10.15587/1729-4061.2023.294119>

1. Introduction

Consumer cooperations in many countries of the world are daily under changing living conditions (environmental and economic factors, hostilities, extreme situations, etc.), increasing the demand for quality organic polycomponent condensed ready-made semi-finished products. Organic

products minimize the synthetic component of the existing range of food products with simultaneous saturation with physiologically functional ingredients (PFI) and providing original rheological and organoleptic properties, increasing the competitiveness of the resulting products [1]. Daily consumption of organic vegetable raw materials (berries, fruits, vegetables, etc.) physically does not make it possible

to form a daily diet since it is characterized by seasonality and complex conditions of transportation, storage, consumer demand, etc. Thus, production complexes need to implement the search for innovative equipment and technological solutions aimed at intensification of resource-efficient processing of organic raw materials into polycomponent ready-made semi-finished products (pastes, powders, etc.), ensuring the competitiveness of production [2]. The feasibility of production of organic polycomponent semi-finished products is the possibility of use as independent products. Also, use in the form of natural ingredients with original rheological and organoleptic properties in various food recipes, minimizing the content of synthetic ingredients, as they have no benefit for rational and preventive nutrition [3]. The quality of the heat-mass-exchange processing of organic plant raw materials is influenced by the degree of resource efficiency of the production cycle, in particular the equipment and technological performance [4]. It is the equipment and technological component responsible for preserving the initial properties of organic raw materials, the duration of heat treatment, the possibility of rational blending, etc., and is the key to the competitiveness of the enterprise. Confirming the relevance of experimental and practical studies aimed at finding and implementing innovative equipment and technological solutions aimed at intensifying the process of thickening of organic polycomponent semi-finished products of high degree of readiness by improving the structures of conventional vacuum reactors. This could lead to the formation of competitive advantages of the production complex with the expansion of the range of high-quality organic polycomponent semi-finished products of high degree of readiness of high degree of readiness for people in European countries.

2. Literature review and problem statement

The modern production of competitive assortments of organic polycomponent semi-finished products of high degree of readiness must meet international standards and have reasonable value, providing confidence from consumers [5]. Semi-finished products of high degree of readiness are characterized by the possibility of self-use and as natural recipe ingredients to maintain daily norm in preventive nutrition. Study [6] reports the results of studies on establishing the level of berry consumption as one of the factors for improving human health, namely help in protecting against a number of diseases, especially cardiovascular. But there are unresolved issues related to the determination of rational volumes of consumption of vegetable raw materials and their consistency. The reason for this may be objective difficulties associated with the need for complex studies, which are complicated by the presence of full material and technical base, complicating research in this area. The option to overcome appropriate difficulties may be to partly resolve them in interconnected research with the possibility of forming a generalized model, which will give a scientific and practical idea for the introduction of innovative equipment and technological solutions. In particular, it is established that consumption of berries/apple juice for a human lipid profile to healthy volunteers (36 women and 14 men) with a recommendation to consume 300 ml of juice a day for 21 days. Regular consumption of berries/apple juice can be an important strategy for reducing the risk of cardiovascular disease due to positive lipid profile modulation and other adult health in-

dicators, confirming the relevance of plant raw material processing. Daily use of polycomponent semi-finished products will make it possible to form a resistance to the impact of the ecological environment, including when people are under extreme conditions (doctors, servicemen, internal interrupted persons, volunteers). The ultimate quality of organic polycomponent semi-finished products is the main component of the competitiveness of the resulting range, necessitating the equipment and technological improvement of the production component, taking into account the mobility of use, ease of use, including secondary energy. This approach is used in [7] regarding studies to determine the feasibility of efficient processing of organic vegetable raw materials, taking into account the level of conservation of PFI, resource efficiency of the equipment and technological component and obtaining original rheological-organoleptic properties. However, the needs of consumer cooperatives should also be taken into account. All this suggests that it is advisable to conduct a study on the efficiency of use of innovative equipment and technological solutions to obtain competitive products.

Most technological operations for the processing of vegetable raw materials are implemented on conventional heat-mass-exchange equipment, which is energy and metal-intensive; the reason is the use of intermediate heat carriers [8]. Complicating performance, in particular, it does not allow the technical mobility of the production complex to be realized at the expense of large volumes of working chambers, in particular in vacuum evaporation apparatus, as well as overheating of certain layers during heat treatment. Thus, providing significant losses of beneficial PFI and organoleptic properties, and therefore the decrease in the purchasing capacity of the obtained range of products and the competitiveness of the production complex as a whole. The option of overcoming appropriate difficulties can be to find innovative engineering solutions to minimize the metal component of the equipment. However, this requires a series of hardware and technological design experiments. All this gives reason to argue that it is advisable to conduct a study on the search for innovative solutions to increase the technical and economic indicators of production [9]. One of the popular innovative ways of intensification of the thickening process (boiling/concentration) is the replacement of intermediate heat carriers in a uniform way of heat supply due to flexible film electric heaters. Thus, by reducing the energy and metal consumption of conventional vacuum equipment under vacuum with the simultaneous ability to give it unified properties (mobility). Thus, [10] shows the peculiarities of concentration of plant raw materials in the conventional evaporation apparatus in the temperature range from 15 °C to 35 °C and the replacement of the steam method of heat supply by electromagnetic waves. However, it is difficult to form an appropriate frequency of electromagnetic waves, and therefore the need to use value electromagnetic generators with certain structural features that complicate the mobility of evaporators. It should be noted that modern production trends, in particular farm companies, require the use of unified mobile equipment with the possibility of direct use at variable production facilities, confirming the relevance of research in this direction. Also, the authors of the work do not emphasize the effects of changes in rheological properties under the conditions of low-temperature concentration and do not consider the possibility of the effect of geometry of the design of the mixer on the intensification of the boiling process, in particular due to the heating of the surface. These

actions are relevant because they can artificially increase the usable surface of heat exchange and design a rational stirrer to ensure intensive mixing of organic raw materials during thickening, confirming the relevance of research in this direction.

In addition to conventional reactors (vacuum evaporators), film evaporators, characterized by the speed of the heat exchange process, are also widely used to boil natural raw materials. But the issues of efficiency of implementation of equipment and technological solutions are unresolved to minimize the impact of intermediate heat carriers not energy and metal consumption as a whole. The reason for this may be objective difficulties related to the use of conventional equipment, and the implementation of actions aimed at increasing resource efficiency are quite costly. The option to overcome appropriate difficulties may be to improve the existing thermal equipment under the conditions of elimination of intermediates, reducing metal capacity and implementation of the possibility of using secondary thermal energy for technical needs. This approach is used in work [11], which provides the calculation of the film evaporator compared to the conventional evaporation apparatus with the installation of the duration of concentration – 200 s, and in the evaporation apparatus – 3600 s. The difference between comparable apparatus is the geometric design of the mixer (blades), but the conditions of its technical use (film current or volumetric raw materials) should be taken into account. All this gives confirms the feasibility of conducting research on the proposal of innovative equipment and technological solutions when improving the reactors. For example, [12] implemented boiled fruit and vegetable puree in a temperature range from 5 °C to 65 °C and, accordingly, a blade rotation frequency (5...200 s⁻¹). This does not mean a preliminary determination of the impact on the rheological properties of the heat transfer coefficient, which does not provide the complete picture of the implementation of the concentration process. Most scientific and practical research is aimed at determining individual equipment and technological indicators for thickening vegetable raw materials. In particular, the effect of the acidity of the natural plant polycomponent blend (peach, papaya, and mango), depending on the thickening temperature and determining the structural and mechanical properties of the resulting semi-finished product, is determined in [13]. But when implementing the process, the authors do not cover the technique of heat supply, so it is difficult whether it is possible to give mobility to the proposed evaporator structure. Work [14] shows a technique of low-temperature boiling of apple juice under the conditions of formation of uniform heat supply in order to preserve the initial properties of PFI. Confirming the relevance of complex studies in the hardware and technological direction for the search for innovative solutions aimed at forming unified (mobile) properties. Work [15] presents a comparison of the processes of concentration of barberry juice in a closed cycle with a conventional thickening in the evaporation apparatus under the conditions of use of intermediate heat carrier. In the course of research, a decrease in the implementation of the process of heat-mass-exchange boiling from 460 min to 350 min at the same rate of raw material flow (0.014 kg/s) was confirmed in the case of thickening of up to 35 % of dry matter (DM). However, considering the need for production complexes in the mobile properties of equipment, the full cycle of boiling cannot correspond to the features of the process implementation, and therefore further apar-

taur-technological studies should be carried out. The obtained condensed semi-finished products of high degree of readiness can be used in the recipes of various foods, for example in the technology of dessert dairy products with fruit and berry dressing. The resulting clots of the product have a dense, uniform consistency and a pure pleasant taste with an attractive color and aroma of fruit and berry filler [16]. Confirming the wide range of use of condensed organic semi-finished products of high degree of readiness.

Taking into account the analysis of literary research in the direction of innovative equipment and technological solutions, there is a need for further experimental and practical studies aimed at:

- determination of ways of formation of unified properties of reactors for thickening under conditions of replacement of an intermediate steam component with a uniform heat supply on an electrical basis;
- taking into account the possibility of artificial increase in the usable surface of heat exchange, which is relevant especially under conditions of low-temperature treatment, which is required during resource-efficient processing of organic raw materials;
- providing conditions for the use of secondary thermal energy for technological needs, including the autonomy of structural elements of advanced reactors.

This is only possible in the implementation of complex studies aimed at determining polycomponent properties, features of change in the structural and mechanical properties, the resulting kinetic of thickening under conditions of comparison with the technical properties of conventional equipment. This approach to intensify the process of thickening of organic polycomponent semi-finished products of high degree of readiness with the possibility of using in a full diet.

3. The aim and objectives of the study

The purpose of this study is to improve the reactor for the thickening of organic plant polycomponent semi-finished products of high degree of readiness. By intensifying the process of thickening of organic polycomponent semi-finished products of high degree of readiness with the possibility of use as independent products and various recipes of food. The obtained improved thickening apparatus will be characterized by mobility for farm production and hotel and restaurant complexes; lack of intermediate heat carriers; ease of use when receiving competitive products directly at the place of use.

This will make it possible to process an organic polycomponent composition on the ground under the conditions of rational heat-mass-change conditions of thickening for the preservation of PFI, reducing transport costs, including storage with the simultaneous elimination of seasonality of consumption.

The following tasks were set to achieve the goal:

- to design innovative equipment and technological solutions aimed at intensifying the process of thickening of organic polycomponent compositions at the places of harvesting and processing under conditions of rational heat-mass-exchange conditions for the preservation of PFI, reducing transport costs, including storage with the simultaneous elimination of seasonality of consumption;
- to confirm under the conditions of experimental and practical testing of the effectiveness of the proposed equip-

ment and technological solutions of an improved design of a unified reactor for the thickening of organic polycomponent compositions into semi-finished products of high degree of readiness.

4. The study materials and methods

The object of our study is the process of thickening of organic polycomponent compositions based on Jerusalem artichoke, apples, pumpkin, cranberry, and dogwood to produce high-level semi-finished products of high degree of readiness using the proposed equipment and technological solutions implemented in a unified reactor. The introduction of the proposed decisions will allow for competitive advantages under the conditions of direct use at production complexes, minimizing raw materials and PFI losses, elimination of a steam component, ensuring the simplification of the use under rational conditions of processing of organic raw materials.

Design of innovative and equipment technological solutions to improve the vacuum reactor for thickening under the conditions of additional heating of the surface of the mixing device, thereby creating competitive advantages of the device. This will reduce the temperature effect on the initial properties of vegetable raw materials.

Laboratory-practical testing studies of proposed equipment and technological solutions aimed at intensification of thickening of organic polycomponent semi-finished products of high degree of readiness on the basis of a unified apparatus for thickening were implemented at laboratory and production complexes of the State Biotechnological University (DBTU). Our research will make it possible under real conditions to determine the practical competitive advantages of the proposed solutions for the production of condensed organic polycomponent semi-finished products of high degree of readiness with original rheological and organoleptic properties. The improved design of a unified reactor is characterized by automatic control of rational boiling modes on the basis of Oven automation tools (Kharkiv, Ukraine) and unified properties, in particular mobility. The description of the improved design of a unified reactor for thickening has a specified principle of operation of the experimental and practical model and the process of experimental and practical testing, which were implemented in accordance with standard procedures in order to maximize the preservation of the initial properties of organic raw materials. Experimental data on the kinetics of heating of organic polycomponent paste-like semi-finished product of high degree of readiness were obtained by measuring the duration of the process by the placed thermocouples in the working chambers of an improved reactor and the basic structure R-P-150m (MZ-2S-316).

The determination of the rheological properties of organic polycomponent compositions under the conditions of boiling in a unified reactor was carried out at the laboratory rotary viscosimeter "Reotest-2" (Germany) in the cylindrical measuring device by Cuét. Determination of the obtained properties of condensed polycomponent semi-finished products of high degree of readiness based on Jerusalem artichoke, apples, pumpkin, cranberry, and dogwood with a variable ratio of components was carried out by the expert board at DBTU on a 5-point scale.

5. Investigation of competitive efficiency of the proposed equipment and technological solutions to implement the process of thickening of organic polycomponent semi-finished products

5.1. Development of innovative equipment and technological solutions for the intensification of the process of thickening of organic polycomponent compositions

Analysis of the equipment and technological component of conventional vacuum-evaporated apparatus allowed us to identify the main directions of improvement based on the introduction of innovative solutions aimed at:

1) the need to replace the heat supply technique, which in most cases is realized by the use of a steam component, which is characterized by uneven heat supply, and therefore the probability of overheating of certain layers of raw materials;

2) formation of unified properties of reactors for the thickening of organic polycomponent semi-finished products in places of technological purpose (farmlands, technological production and hotel-restaurant complexes);

3) the intensification of the process of heat-mass exchange by improving the design of the mixing device, the outer surface of which is additionally heated, as well as ensuring the structural feature of the reactor for the use of secondary energy.

Under laboratory-practical conditions, a model structure of a unified reactor (Fig. 1) with the possibility of direct use in variable technological capacities for the thickening of organic polycomponent compositions to produce semi-finished products of high degree of readiness was designed. Heating the working surface of the apparatus (2) and the mixing device (3) is realized by the film-like resistive electric heater of radiation type (1) (FIREhRT [17]). Additional heating of the outer surface of the moving device provides an artificial increase in the surface of the usable heat exchange of the device by 0.26 m². At the bottom, the model structure of the reactor has an automatic locking pipe to discharge a condensed semi-finished product (4), and the working chamber itself (2) is mounted on locking racks (5), connected to a mobile platform (6). Mounting the reactor working chamber on the mobile platform (6) makes it possible to ensure the mobility of the structure for use directly under the conditions of production capacity (at the places of harvesting of organic raw materials, production shops, hotel and restaurant complexes, etc.).

The mobile platform (6) makes it possible in the technical zone to smear the motor compartment (7) with a drive shaft with coupling connectors (8) to transmit rotational motion to a mixing device (3). Reducing the weight of the lid (17) under the possible upper location of the engine. There is also a compartment with a vacuum pump and a gearbox of a lifting rod (9). It should be noted that low-temperature autonomous fans that work from Peltier elements (16) are mounted in the structure of the mobile platform (6) to prevent the overheating of motor compartments. These elements are mounted in the high-temperature area of the reactor cover and under the conditions of transformation of secondary heat into low-voltage energy for the operation of exhaust fans. In addition, for the safety of the use of an advanced reactor, the moving platform (6) has a hand stopper (brake, 10).

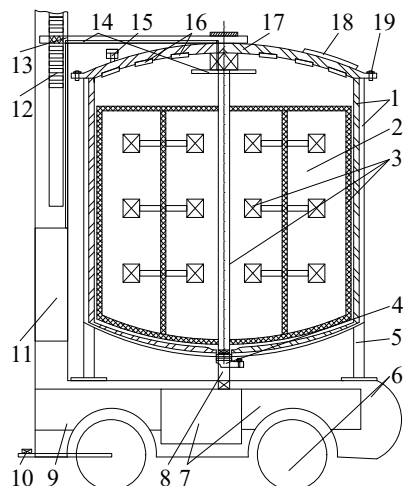

Fig. 1. Scheme of an advanced model structure of a unified reactor for the thickening of organic raw materials: 1 – film-shaped resistive electric heater of radiation type (FIREhRT) with a heat insulating surface; 2 – working chamber; 3 – mixing device whose surface is heated; 4 – a pipe for removal of condensed semi-finished products; 5 – racks; 6 – mobile site; 7 – motor department; 8 – drive shaft with coupling connectors; 9 – gearbox; 10 – hand stopper; 11 – block of control of the technological process of thickening; 12 – guide lifting rod; 13 – connecting bar to lift the lid; 14 – spray with a technical pipeline; 15 – shut-off valves; 16 – Peltier elements; 17 – lid; 18 – loading hopper; 19 – mountable retainers

The qualitative implementation of the heat-mass-exchange treatment of the organic polycomponent mixture into semi-finished products of high degree of readiness is realized by the automatic control unit (11), which makes it possible to control the thickening temperature, the speed of rotation of the mixing device (3).

The lifting of the reactor cover (17) is realized by the interaction of the guide lifting rod (12) and the connecting rod (13) intended for lifting the lid. To ensure the sanitary treatment of the work surfaces, the improved design has a built-in spray with a technical pipeline (14), which is connected to the water supply equipment in the production cycle. The proposed design has a standard shut-off equipment for vacuum evaporators (15), and on the lid (17) there is a loading hopper (18) for the introduction into the semi-finished product of the recipe possible ingredients, depending on the conditions of use. The lid (17), in turn, has a rubber seal to prevent depressurization during vacuum pump operation and is fixed by means of cap locks (19).

The process of thickening of organic polycomponent compositions in the advanced model structure of a unified reactor is characterized by a conventional technological process (for example, with the basic structure R-P-150m (MZ-2S-316) under the conditions of consideration of thermophysical features of raw materials. Moreover, the unified properties of the improved reactor allow it to be used directly in the technological cycle without being tied to stationary places, intermediate heat carriers, and technical highways, unlike traditional designs;

4) to confirm under the conditions of experimental and practical testing the effectiveness of the proposed equipment and technological solutions of an improved design of a unified reactor for the thickening of organic polycomponent

compositions into semi-finished products of high degree of readiness.

5. 2. Experimental and practical testing of hardware and technological solutions in the improved design of the unified reactor

The basic features of the implementation of the heat-mass-exchange process of thickening of organic raw materials are minimization of the duration of the technological cycle under conditions of uniform heat supply and artificial increase in the surface of heat exchange, which is implemented in the improved reactor structure. In particular, during the thickening process, it is necessary to preliminary determine the rheological properties of raw materials, especially when it comes to polycomponent compositions with the subsequent determination of the resulting organoleptic properties of semi-finished products of high degree of readiness.

The experimental verification of the improved structure of a unified reactor with a mixing device, the outer surface of which was additionally heated by FIREhRT (Fig. 1, pos. 1, 3) was carried out under the conditions of condensation of the polycomponent composition. The base consisted of organic raw materials: Jerusalem artichoke, apples, pumpkin, cranberry, and dogwood in the ratio (30:25:20:15:10 – composition “B”). As a result of the studies, the dynamic characteristics of the viscous properties of the polycomponent paste under the conditions of variable shear rate within the temperature range from 30 °C to 60 °C (Fig. 2) were obtained.

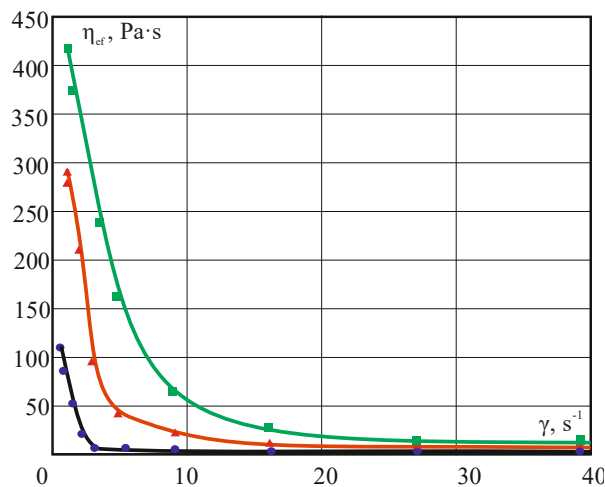

Fig. 2. Change in the dynamic viscosity of organic polycomponent paste-like composition in a temperature range from 35 °C to 55 °C (solids content – 30 %): ■ – 35 °C; ▲ – 45 °C; ● – 55 °C

An analysis of the characteristics of changes in the dynamic viscosity of the organic polycomponent paste-like composition confirms preliminary prognosis for decreased viscosity with increasing temperature, but the temperature itself is a major factor in maintaining the initial content of PFI. The initial viscosity value is 440 Pa·s at 35 °C, 292 Pa·s at 45 °C and, respectively, 118 Pa·s at 55 °C. The nature of polycomponent pastes corresponds to the non-Newtonian liquids and after exceeding the shear effort (20 s⁻¹), they begin to behave in the same rheological properties. For example, when concentrating an organic polycomponent composition of the paste at a temperature of 55 °C and a

shear speed within 3.0...4.5 s⁻¹, the effective viscosity is in the range of 22...3.5 Pa·s.

To determine consumer interest in the obtained organic polycomponent semi-finished product of high degree of readiness from Jerusalem artichoke, apples, pumpkin, cranberry, and dogwood, additional organoleptic evaluation was performed (Table 1).

Table 1

Data of organoleptic evaluation of an organic multicomponent paste-like semi-finished product of a high degree of readiness

Paste indicator	Characteristic		
	Composition «A» (25:25:25:15:10)	Composition «B» (30:25:20:15:10)	Composition «C» (20:25:15:20:20)
Appearance	Homogeneous multicomponent paste-like mass		
Taste and smell	Monochromatic pronounced Jerusalem artichoke, apples. With a slight tang of cranberry and dogwood. Pumpkin is almost not felt	Pleasant harmonious taste of all components without an obvious taste of pumpkin	A pronounced taste and smell of cranberries and dogwoods with a simultaneous pleasant taste of other components
Color	Light yellow	Light red with a certain shade of yellow	Light red
Consistency	Homogeneous viscous and smearing organic matter		

According to organoleptic indicators, all the proposed compositions of organic polycomponent paste-like semi-finished products of high degree of readiness have original features and are interesting for consumers. However, the composition “A” has a monochrome taste and smell of Jerusalem artichoke and apples with a slight taste of cranberry and dogwood, and the pumpkin is almost not felt. “B” is a pleasant harmonious taste of all components without the clear taste of pumpkin, and the composition “B” is characterized by a pronounced taste and smell of cranberries and dogwood with a simultaneous pleasant taste of other components.

Practical testing of the improved structure of a unified reactor with a mixing device is implemented under the conditions of experimental and practical determination of kinetics in heating the organic polycomponent paste-like semi-finished product of high degree of readiness. In particular, on the example of the composition “B” under the conditions of comparing the results with the base design R-P-150m (MZ-2S-316) (Fig. 3).

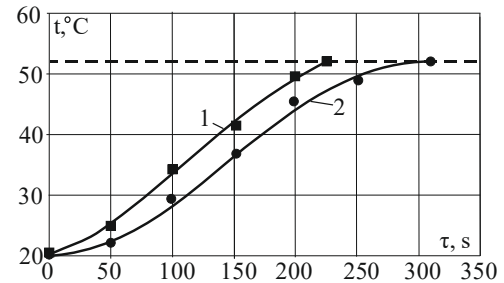

Fig. 3. Experimental data on the kinetics of heating an organic polycomponent paste-like semi-finished product of high degree of readiness: 1 – improved design of a unified reactor with a mixing device; 2 – basic structure R-P-150m (MZ-2S-316)

It is determined that the duration of reaching the stationary boiling point of the organic polycomponent composition when condensed in the improved design of a unified reactor with the mixing device is 225 s. And in the base structure – 310 s, respectively. According to the comparative equipment and technological parameters of the aforementioned devices (Table 2, in the calculations we neglected the losses of heat to the environment), this is due to the general decrease in metal consumption due to the electrical heating of working surfaces by 33 %.

In addition, the technological duration of the thickening process is reduced by 30 %.

Our data in Table 2 indicate an increase in the efficiency of the improved vacuum reactor for the thickening of organic raw materials compared to the basic structure. The specific heat consumption of the improved construction of the vacuum reactor was found, which is reduced by 20 %. This result is achieved by increasing the heating area of the apparatus by using the heating of the mixing device. The specific metal consumption of the structure is also significantly reduced by 47 %. The additional heating of the outer surface of the mixing device makes it possible to increase the surface of heat exchange by 26 %, with the duration of the thickening process decreasing by 30 %. As a result of the studies, the technical indicators of the improved vacuum reactor for the thickening of organic raw materials were identified (Table 3).

Table 2

Comparison of the equipment and technological parameters of the improved unified reactor with a mixing device with the base structure R-P-150m (MZ-2S-316)

Indicator	R-P-150m (MZ-2S-316)	Organic raw material thickening reactor
Heating surface	$F^*=0.98 \text{ m}^2$	$F=F^*+F_{\text{stirrers}}=0.98+0.26=1.24 \text{ m}^2$
Mass	$m^*=380 \text{ kg}$	$m=m^*-m_{\text{shirts}}+m_{\text{ppREnVT}}=380-138+10=252 \text{ kg}$
The heat of heating the device	$Q_{\text{ap}}=m_1 \cdot c_c(t_2-t_1)+m_2 \cdot c_c(t_3-t_1)=-200 \cdot 0.48(52-20)+138 \cdot 0.48(143-20)=11219.52 \text{ kJ}$	$Q_{\text{ap}}=m_1 \cdot c_c(t_2-t_1)=-210 \cdot 0.48(52-20)=3225.6 \text{ kJ}$
The heat of heating the product	$Q_{\text{pr}}=m \cdot c \cdot (t_k-t_n)=240 \cdot 3.7 \cdot (52-20)=28416 \text{ kJ}$	$Q_{\text{pr}}=m \cdot c \cdot (t_k-t_n)=240 \cdot 3.7 \cdot (52-20)=28416 \text{ kJ}$
Total heat consumption	$Q_{\text{zag}}=325655.52 \text{ kJ}$	$Q_{\text{zag}}=317661.6 \text{ kJ}$
Heat treatment time	$\tau=Q/Fk\Delta t=325655.52/0.98 \cdot 1454 \cdot 91=2511 \text{ s}$	$\tau=Q/Fk\Delta t=317661.6/1.24 \cdot 1620 \cdot 91=1737 \text{ s}$
Specific metal capacity	$m=M/F=380/0.98=387 \text{ kg/m}^2$	$m=M/F=252/1.24=203 \text{ kg/m}^2$
Specific heat consumption during heating	$q_p=Q/m=39635.52/240=165.1 \text{ kJ/kg}$	$q_p=Q/m=31641.6/240=131.8 \text{ kJ/kg}$
Product heating time (from experimental data, Fig. 3)	$\tau=310 \text{ s}$	$\tau=225$

Note: * – information on the basic structure R-P-150m (MZ-2S-316) was taken from paper [18]

Table 3
Specifications of the advanced model of vacuum evaporator with a unified mixer

Characteristic	Indicator
Geometric capacity, m ³	0.325
Working capacity, m ³	0.15
Heating surface, m ²	1.24
Drive power, kW	0.55
Surface temperature, °C	to 140
Agitator speed, min ⁻¹	18
Weight, kg	252

Experimental and practical testing studies of the improved design of the unified reactor confirm the effectiveness of the proposed equipment and technological solutions for the qualitative implementation of the process of thickening of organic polycomponent compositions into semi-finished products of high degree of readiness.

6. Discussion of the efficiency of introducing equipment and technological solutions based on the improved design of a unified reactor

The proposed equipment and technological solutions are the key to the formation of competitive properties of mobile reactors for the thickening of plant polycomponent semi-finished products of high degree of readiness under conditions of elimination of a steam component, an increase in the surface of the heat exchange of the mixing device. Thus, providing a significant advantage in operating duration, in addition, the use of Peltier elements made it possible to use secondary heat on the autonomy of exhaust fans in the motor compartments of the mobile platform. Such actions in general will make it possible to place advanced reactors directly at processing complexes (farmlands), processing/production and hotel-restaurant complexes forming the processing of natural raw materials according to consumers. The complexity of using conventional reactors for condensing [18] is associated with the presence of a steam component, which greatly increases the energy and metal consumption of existing non-mobile equipment. Including increasing the cost of transportation/storage and processing of organic raw materials, leading to losses of valuable PFI. For example, experimental and practical studies of boiling natural puree in a conventional vacuum-evaporated apparatus with an improved mixer, whose heating of the inner space was also implemented at the expense of the steam has been implemented in [19]. However, such design solutions, in addition to the artificial complication of the operational use of vacuum evaporators, can lead to hydraulic shocks due to a significant difference in concentration and vapor temperature. Therefore, the rejection of intermediate media not only increases the performance of the devices for thickening but also makes it possible to reduce metal intensity, to ensure uniform heat supply and mobility of the structure. For example, in [20], one of the practical solutions of the vacuum evaporation on the basis of the electrical method of heat supply and, according to comparative equipment and technological data, the improved apparatus has significant competitive advantages. Unlike [10] where the concentration of plant raw materials is realized in the conventional evaporation apparatus in the

temperature range from 15 °C to 35 °C under conditions of replacement of the steam technique of heat supply to electromagnetic waves. Thus, reducing the metal consumption of the structure of the evaporator, and the introduction of the electrical technique of heat supply will make it possible to form a clear stabilization of the temperature range and the mobility of the improved reactor.

In the course of the introduction of the proposed equipment and technological solutions, an advanced model structure was designed of the reactor for the thickening of organic raw materials, which has an increased surface of heat exchange due to the heating of the mixing device (0.26 m², Fig. 1, Table 1). The improved reactor is characterized by a lower duration of entering the stationary regime (225 s, Fig. 3), unlike the conventional reactor with steam heating – 310 s, respectively. Thus, to a large extent reducing the operating duration of thickening as a whole, which will preserve valuable PFI and organoleptic properties.

The experimental and practical testing of the improved reactor structure for the thickening of organic raw materials was implemented on the polycomponent condensed composition “B” (Table 1) on the basis of Jerusalem artichoke, apples, pumpkin, cranberry, and dogwood. In the course of research, the change in the structural and mechanical properties of organic pastes in a variable temperature range was determined, from 35 °C to 55 °C (above, the thickening temperature was not raised for maximum preservation of PFI. It was established that when the organic multicomponent composition of the paste is thickened at a temperature of 55 °C and a shear rate in the range of 3.0...4.5 s⁻¹, the effective viscosity is in the range of 22...3.5 Pa·s (Fig. 2). After thickening, the semi-finished products were evaluated for their organoleptic properties (Table 1). Composition “A” had a single-toned pronounced taste and smell of Jerusalem artichoke and apple with a slight aftertaste of cranberry and dogwood, and pumpkin is almost not noticeable. Composition “B” had a pleasant harmonious taste of all components without a clear taste of pumpkin, and composition “C” was characterized by a pronounced taste and smell of cranberry and dogwood with a simultaneous pleasant taste of other components. Confirming all three options of polycomponent semi-finished products for further sale to consumers, as products of a high degree of readiness with original organoleptic and rheological properties.

The obtained equipment and technological and operational properties of the improved reactor structure (Fig. 1) have the advantages presented in the reduction of the specific heat consumption of the improved structure by 20 % by increasing the area of heating of the device by 26 %. The specific metal consumption of the structure is reduced by 47 % (Tables 2, 3). Confirming the efficiency of the proposed engineering and technological solutions under the conditions of use of an improved structure in the working temperature range of thickening within 35...55 °C for resource-efficient processing of organic raw materials and conservation of PFI. One of the restrictions in the study of thickening modes of organic polycomponent compositions is the clear stabilization of the temperature of the heating surface, which in this case is minimized by the use of the mixing device with the heating surface (Fig. 1, pos. 3). The disadvantage is the difficulty of using mobile vacuum reactors by large processing enterprises, but the work is focused precisely to ensure mobility of equipment. At the same time,

we note that neglect of the above recommendations will reduce the competitive properties of the use of an advanced reactor structure for the thickening of organic raw materials. The practical introduction of the improved design of a unified reactor will make it possible to form competitive advantages, first of all, by direct use in technological needs in places of collection of organic raw materials, production complexes, etc. The rejection of the steam component also effectively influenced the general technical and operational and technological properties, providing an increase in the range of organic paste-like semi-finished products of high degree of readiness at affordable cost.

Further studies of the thickening of organic polycomponent semi-finished products in the improved reactor structure will be aimed at increasing the efficiency of the use of Peltier elements for the technological needs of the mobile apparatus.

7. Conclusions

1. The introduction of heating of the working chamber of the reactor with a film-like resistive electric heater of radiation type allowed us to eliminate the component of intermediate heat carriers with a decrease in the total metal consumption of the apparatus. Additional heating of the stirring device with the aforementioned electric heater increased the total heat exchange area to 1.24 m² (prototype – 0.98 m²). This also led to a decrease in specific heat consumption by 20 %, specific metal capacity by 47 %, and process duration by 30 %.

2. Experimental and practical testing of the improved reactor for the thickening of organic raw materials allowed us to determine the nature of changes: rheological and organoleptic properties, kinematic features of heating of a paste-like semi-finished product and hardware-technological and technical parameters of the reactor under conditions of comparison with the basic structure. In particular, when the organic polycomponent composition is thickened at 55 °C and a shift speed within 3.0...4.5 s⁻¹, the effective viscosity is in the range of 22...3.5 Pa·s. According to the results of organoleptic evaluation, the composition “B” has a pleasant

harmonious taste of all components without the clear taste of pumpkin (all other compositions are also for practical implementation to consumers). In addition, a reduction in the specific heat consumption of the improved structure is achieved, by 20 %, by increasing the heating area by 26 %. Reduction of the specific metal consumption of the structure by 47 % and reduction of the technological duration of the thickening process by 30 %.

Conflicts of interest

The authors declare that they have no conflicts of interest in relation to the current study, including financial, personal, authorship, or any other, that could affect the study and the results reported in this paper.

Funding

The study was conducted without financial support.

Data availability

All data are available in the main text of the manuscript.

Use of artificial intelligence

The authors used artificial intelligence technologies within the permissible framework to provide their own proven data, which is described in the section with the research methodology.

Acknowledgments

The work was performed within the State Budget Topic No. 4-22-23 BO “Innovative technologies for the conservation and processing of plant raw materials into safe special purpose products”.

References

- Misra, N. N., Koubaa, M., Roohinejad, S., Juliano, P., Alpas, H., Inácio, R. S. et al. (2017). Landmarks in the historical development of twenty first century food processing technologies. *Food Research International*, 97, 318–339. doi: <https://doi.org/10.1016/j.foodres.2017.05.001>
- Chen, X., Gao, Z., McFadden, B. R. (2020). Reveal Preference Reversal in Consumer Preference for Sustainable Food Products. *Food Quality and Preference*, 79, 103754. doi: <https://doi.org/10.1016/j.foodqual.2019.103754>
- Cherevko, O., Mykhaylov, V., Zagorulko, A., Zahorulko, A. (2018). Improvement of a rotor film device for the production of high-quality multicomponent natural pastes. *Eastern-European Journal of Enterprise Technologies*, 2 (11 (92)), 11–17. doi: <https://doi.org/10.15587/1729-4061.2018.126400>
- Boesveldt, S., Bobowski, N., McCrickerd, K., Maître, I., Sulmont-Rossé, C., Forde, C. G. (2018). The changing role of the senses in food choice and food intake across the lifespan. *Food Quality and Preference*, 68, 80–89. doi: <https://doi.org/10.1016/j.foodqual.2018.02.004>
- O’Shea, N., Ktenioudaki, A., Smyth, T. P., McLoughlin, P., Doran, L., Auty, M. A. E. et al. (2015). Physicochemical assessment of two fruit by-products as functional ingredients: Apple and orange pomace. *Journal of Food Engineering*, 153, 89–95. doi: <https://doi.org/10.1016/j.jfoodeng.2014.12.014>
- Habanova, M., Saraiva, J. A., Holovicova, M., Moreira, S. A., Fidalgo, L. G., Haban, M. et al. (2019). Effect of berries/apple mixed juice consumption on the positive modulation of human lipid profile. *Journal of Functional Foods*, 60, 103417. doi: <https://doi.org/10.1016/j.jff.2019.103417>

7. Pylypenko, O. (2017). Development of Ukrainian food industry. *Scientific Works of NUFT*, 23 (3), 15–25. Available at: http://nbuv.gov.ua/UJRN/Npnukht_2017_23_3_4
8. Marco, S.-C., Adrien, S., Isabelle, M., Manuel, V.-O., Dominique, P. (2019). Flash Vacuum-Expansion Process: Effect on the Sensory, Color and Texture Attributes of Avocado (*Persea americana*) Puree. *Plant Foods for Human Nutrition*, 74 (3), 370–375. doi: <https://doi.org/10.1007/s11130-019-00749-3>
9. Zahorulko, A., Zagorulko, A., Yancheva, M., Dromenko, O., Sashnova, M., Petrova, K. et al. (2020). Improvement of the continuous "pipe in pipe" pasteurization unit. *Eastern-European Journal of Enterprise Technologies*, 4 (11 (106)), 70–75. doi: <https://doi.org/10.15587/1729-4061.2020.208990>
10. Borchani, M., Masmoudi, M., Ben Amira, A., Abbès, F., Yaich, H., Besbes, S. et al. (2019). Effect of enzymatic treatment and concentration method on chemical, rheological, microstructure and thermal properties of prickly pear syrup. *LWT*, 113, 108314. doi: <https://doi.org/10.1016/j.lwt.2019.108314>
11. Zahorulko, A., Zagorulko, A., Cherevko, O., Dromenko, O., Solomon, A., Yakobchuk, R. et al. (2021). Determination of the heat transfer coefficient of a rotary film evaporator with a heating film-forming element. *Eastern-European Journal of Enterprise Technologies*, 6 (8 (114)), 41–47. doi: <https://doi.org/10.15587/1729-4061.2021.247283>
12. Dolores Alvarez, M., Canet, W. (2013). Time-independent and time-dependent rheological characterization of vegetable-based infant purees. *Journal of Food Engineering*, 114 (4), 449–464. doi: <https://doi.org/10.1016/j.jfoodeng.2012.08.034>
13. Vicente, A. R., Manganaris, G. A., Darre, M., Ortiz, C. M., Sozzi, G. O., Crisosto, C. H. (2022). Compositional determinants of fruit and vegetable quality and nutritional value. *Postharvest Handling*, 565–619. doi: <https://doi.org/10.1016/b978-0-12-822845-6.00019-1>
14. Ding, Z., Qin, F. G. F., Yuan, J., Huang, S., Jiang, R., Shao, Y. (2019). Concentration of apple juice with an intelligent freeze concentrator. *Journal of Food Engineering*, 256, 61–72. doi: <https://doi.org/10.1016/j.jfoodeng.2019.03.018>
15. Hobold, G. M., da Silva, A. K. (2019). Visualization-based nucleate boiling heat flux quantification using machine learning. *International Journal of Heat and Mass Transfer*, 134, 511–520. doi: <https://doi.org/10.1016/j.ijheatmasstransfer.2018.12.170>
16. Solomon, A., Bondar, M., Dyakonova, A. (2019). Substantiation of the technology for fermented sour-milk desserts with bifidogenic properties. *Eastern-European Journal of Enterprise Technologies*, 1 (11 (97)), 6–16. doi: <https://doi.org/10.15587/1729-4061.2019.155278>
17. Zahorulko, A. M., Zahorulko, O. Ye. (2016). Pat. No. 108041 UA. Hnuchkyi plivkovyi rezystyvnyi elektronahrivach vprominiuichoho typu. No. u201600827; declared: 02.02.2016; published: 24.06.2016, Bul. No. 12. Available at: <https://repo.btu.kharkov.ua/handle/123456789/15246>
18. R-P-150m (MZ-2S-316) - Reaktor vakuum vyparnoy. Available at: <https://www.oborud.info/product/jump.php?6109&c=619>
19. Cherevko, A., Mayak, O., Kostenko, S., Sardarov, A. (2019). Experimental and simulation modeling of the heat exchange process while boiling vegetable juice. *Progressive technique and technologies of food production enterprises, catering business and trade*, 1 (29), 75–85. doi: <https://doi.org/10.5281/zenodo.3263532>
20. Zahorulko, A., Zagorulko, A., Fedak, N., Sabadash, S., Kazakov, D., Kolodnenko, V. (2019). Improving a vacuum-evaporator with enlarged heat exchange surface for making fruit and vegetable semi-finished products. *Eastern-European Journal of Enterprise Technologies*, 6 (11 (102)), 6–13. doi: <https://doi.org/10.15587/1729-4061.2019.178764>