

*The object of research is the processes of occurrence, perception, and redistribution of loads in the structure of a removable module for the situational adaptation of the flat car, model 13-7024, to the transportation of strategic cargoes.*

*In order to transport strategic cargoes, including military equipment, agricultural machines, etc., the use of a removable module is proposed on the flat car. Appropriate calculations were performed to determine parameters for the structural components of the removable module. At the same time, the profile of the frame was determined by the value of the maximum bending moment acting in its cross-section. The thickness of the sheet, which forms a horizontal plane for placing the load, was calculated according to the Bubnov-Galyorkin method. To substantiate the determined parameters of the structural components of the removable module, its strength was calculated. The calculation results showed that the strength of the removable module under the considered operating load schemes is ensured.*

*A feature of the research results is that the use of the proposed structure of the removable module makes it possible to expand the range of goods transported by flat cars without improving them.*

*The field of practical use of the results is the engineering industry, in particular, railroad transport. The conditions for the practical application of the research results are the use of variable height fittings in the removable module.*

*Our studies will contribute to devising the recommendations for increasing the efficiency of the operation of flat cars through their situational adaptation to the transportation of strategic cargoes. In add, the results could prove useful for the construction of modern structures of modular vehicles*

*Keywords: railroad transport, flat car, situational adaptation of the car, removable module, loading capacity of the removable module*

UDC 629.45  
DOI: 10.15587/1729-4061.2024.299537

# SITUATIONAL ADAPTATION OF THE MODEL 13-7024 FLAT CAR FOR TRANSPORTING STRATEGIC CARGO

**Alyona Lovska**

*Corresponding author*

Doctor of Technical Sciences, Professor  
Department of Wagon Engineering  
and Product Quality\*\*

E-mail: alyonaLovskaya.vagons@gmail.com

**Volodymyr Nerubatskyi**

PhD, Associate Professor\*

**Oleksandr Plakhtii**

PhD, Associate Professor\*

**Sergiy Myamlin**

PhD, Researcher\*

\*Department of Electrical Energetics, Electrical  
Engineering and Electromechanics\*\*

\*\*Ukrainian State University of Railway Transport  
Feuerbakh sq., 7, Kharkiv, Ukraine, 61050

Received date 15.01.2024

Accepted date 26.03.2024

Published date 30.04.2024

**How to Cite:** Lovska, A., Nerubatskyi, V., Plakhtii, O., Myamlin, S. (2024). Situational adaptation of the model 13-7024 flat car for transporting strategic cargo. *Eastern-European Journal of Enterprise Technologies*, 2 (7 (128)), 38–46. doi: <https://doi.org/10.15587/1729-4061.2024.299537>

## 1. Introduction

Railroad transport has long been a leading component of the transportation industry, which provides for the development of economies in many European countries [1, 2]. In order to maintain the branch of primacy, as well as to meet the needs of the economy, it is important to put into operation modern designs of freight cars with improved technical and operational indicators [3–5].

One of the most common types of cars used in international traffic is flat cars [6, 7]. At the same time, the use of these cars in international traffic is limited by their design features. Specifically, by the fact that a significant part of the fleet of these cars is made up of specialized structures that are adapted to the transportation of a specific range of goods.

A possible solution to the problem of a shortage of cars is replenishment of the car fleet, but this requires significant capital investments. A more rational solution is the situational adaptation of the existing fleet of cars to the transportation of specific types of cargo, including strategic ones (military equipment, agricultural machines, etc.). This will not only increase the efficiency of the transportation process

but also help save capital costs for the purchase of new cars. In this regard, the issue of situational adaptation of the existing fleet of flat cars for the transportation of strategic cargo is a rather urgent issue.

## 2. Literature review and problem statement

In paper [8], an analysis of the design of a long-based flat car was carried out. Features of calculating the strength of its supporting structure under operating loads were highlighted. The results of the strength calculation fully justify the structural solutions adopted during the design of the supporting structure of the flat car. At the same time, the design of this flat car is narrowly oriented and does not allow for the transportation of a wide range of goods.

In work [9], dynamic and strength characteristics of a long-based flat car for intermodal transportation are studied. The determination of the studied indicators was carried out by computer simulations using modern software tools. The calculation results confirmed the expediency of the structural solutions made during the design of the flat car.

However, this structure of the flat car is specialized and intended for the transportation of containers, which limits its demand in operation.

In work [10], the strength of a long-based flat car for container transportation is calculated. To this end, the authors used classical methods of resistance of materials to determine the bending moments that occur in the sections of the supporting structure of the flat car. At the next stage, the strength of the supporting structure of the flat car was determined using the finite element method. The work provides an analysis of the results and prospects for the further advancement of this research. It is important to say that the design of this type of car is oriented towards the transportation of a specific type of cargo. This limits its demand in operation.

The study of the strength of the load-bearing structure of the flat car depending on the magnitude of its deformations is carried out in paper [11]. It is important to emphasize that the studies were carried out using experimental methods, in particular, electrical strain gauges. The results of these studies made it possible to determine the most loaded structural components of the flat car. However, the authors did not offer solutions to improve the strength of the supporting structure of the flat car by improving it.

For the situational adaptation of the flat car to the transportation of long cargo, work [12] proposed the use of a special removable module. Fastening of the module on the flat car is provided with the use of fitting stops. The corresponding scientific justification of the construction of the detachable module is given. But this design of the removable module involves the use of elastic-friction connections in the frame. Such a solution complicates the process of its maintenance and repair.

A similar solution was proposed in [13]. To that end, for the situational adaptation of the flat car to the transportation of various types of cargo, it is suggested to use a removable module of the FLAT RACK type. A feature of the module is the presence of elastic-viscous connections in the fittings, which contributes to the reduction of longitudinal loads acting on it during operation. The authors provide the relevant theoretical justification of the proposed design of the removable module. However, long-base constructions of flat cars with special superstructures for placing fitting stops are currently in use. These superstructures are used due to the fact that the frame of the flat car has the shape of a beam with equal bending resistance. In this regard, the frame has a variable height of the profiles of its execution along the length. And, accordingly, the use of such a removable module on similar flat cars requires appropriate scientific justification.

Features of calculating the strength of the improved frame of the flat car are highlighted in work [14]. To this end, the finite element method was applied. The authors determined the distribution fields of the maximum equivalent stresses in the supporting structure of the flat car. The obtained stresses are within the limits of permissible values, which confirmed the feasibility of the design solutions regarding its implementation. However, the authors did not propose measures for the situational adaptation of this car to the transportation of various types of cargo, which would increase the efficiency of its operation.

The study of the strength of the load-bearing structure of a long-based flat car is reported in [15]. The peculiarity of this design of the flat car is the absence of a girder beam

along the length of the frame. To justify such a solution, the authors conducted not only theoretical studies of its load but also experimental ones. The results indicate the possibility of operating such a car on main lines. However, this design of the flat car does not provide the possibility of its application to the transportation of a wide range of goods, which narrows the range of its use.

Our review of the literature [8–15] reveals that the issues of improving the load-bearing structures of flat cars are quite relevant. However, to improve the effectiveness of their use for strategic purposes, the issue of situational adaptation to such transportation needs to be resolved.

---

### 3. The aim and objectives of the study

---

The purpose of our study is the scientific substantiation of the situational adaptation of the flat car, model 13-7024, to the transportation of strategic cargo by using a removable module. This will contribute to increasing the efficiency of the operation of flat cars and the profitability of railroad transportation.

To achieve this goal, the following tasks are defined:

- to determine parameters for the structural components of a removable module for the situational adaptation of the flat car to the transportation of strategic cargo;
- to investigate the dynamic loading and strength of the removable module when it perceives vertical loads;
- to investigate the dynamic loading and strength of the removable module when it receives longitudinal loads.

---

### 4. The study materials and methods

---

The object of research is the processes of occurrence, perception, and redistribution of loads in the design of a removable module for the situational adaptation of the flat car to the transportation of strategic cargoes.

The main hypothesis of the study assumes that for the possibility of transportation of strategic cargoes on the flat car, model 13-7024, it is possible to use a special design of the removable module.

The supporting structure of the model 13-7024 flat car, which is one of the most promising on the 1520 mm track, contains a frame consisting of two subframes placed in cantilever parts (Fig. 1). In addition, the frame design includes two sidewalls of a welded construction of a T-shaped cross-section of variable stiffness. These sidewalls consist of bottom and top sheets, 22 mm thick, and vertical sheets, 8 mm thick. The frame of the flat car includes two end beams, six intermediate beams, two additional intermediate beams. In order to be able to transfer longitudinal loads from the girder beams of the subframes to the sidewalls, four diagonal braces of the T-shaped section are provided. These braces transfer longitudinal loads from the girder beams of the subframes to sidewalls (TU U 35.2-05763814-062:2005).

For the possibility of transportation of strategic cargoes, including military equipment, agricultural machines, etc., the use of a removable module on the flat car is proposed (Fig. 2).

The peculiarity of such a removable module is that it is a frame structure (Fig. 3), covered on top with a metal sheet. Fitting stops are installed in the corner parts of the removable module. In this case, the height of the stops on

the side of the console part of the flat car is higher than on the opposite side of the module. This solution makes it possible to create a straight horizontal plane for placing the transported cargo.

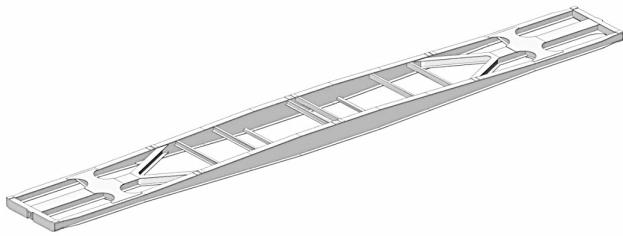

Fig. 1. Supporting structure of the flat car, model 13-7024

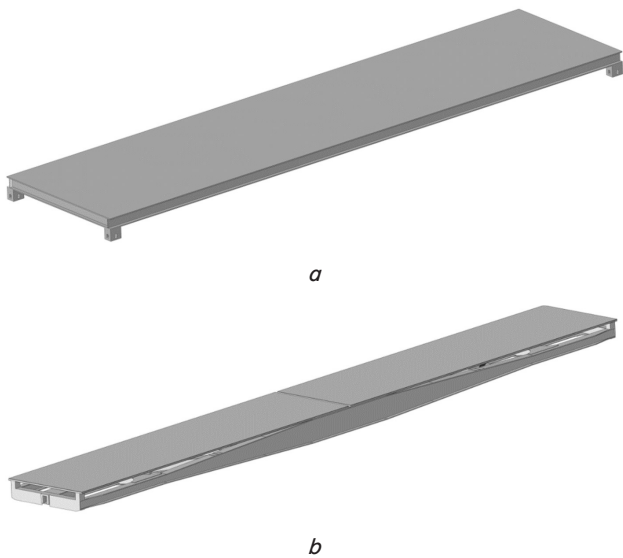

Fig. 2. Removable module: *a* – general view; *b* – placement on a flat car

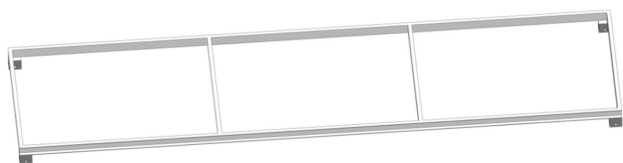

Fig. 3. Removable module frame

In order to determine the execution profiles of the frame, diagrams of the internal forces that arise in the module when it is loaded are constructed. In this case, the module is considered as a rod system on four supports (Fig. 4).

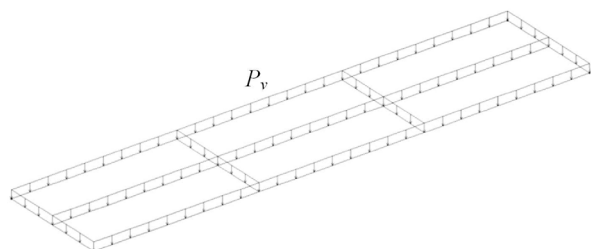

Fig. 4. Design diagram of the removable module

The calculation was carried out using the PC “Lira - CAD” (Ukraine) [16] with the help of built-in options.

To substantiate the result, a calculation was performed on the strength of the removable module when it receives a vertical load. Graphic works on its construction were carried out using SolidWorks (France) [17, 18]. The finite element method was applied as the calculation method. It was implemented using SolidWorks Simulation (France). The calculation scheme of the module is shown in Fig. 5.

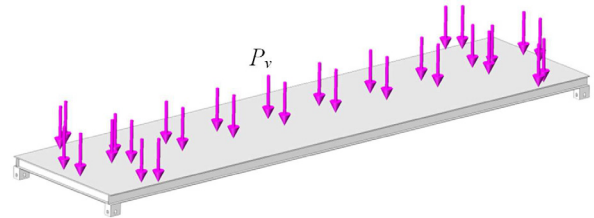

Fig. 5. Design diagram of the removable module

It is taken into account that the module tests the vertical load  $P_v$  using its full carrying capacity. The module was fastened using fittings.

The finite-element model of the module is formed by isoparametric tetrahedra [19–21]. To determine their optimal value, the graphic-analytical method is used. Taking this into account, the finite element model has 38,893 elements and 12,561 nodes. The maximum size of the element was 120 mm, and the minimum – 24 mm.

Appropriate calculations were performed to determine the dynamic load of the removable module. In this case, two load schemes of the removable module are taken into account:

- reception of vertical loads by the lifting module;
- reception of longitudinal loads by the removable module.

In this case, the calculation of the removable module when it perceives vertical loads is carried out in accordance with the scheme shown in Fig. 5.

When studying the longitudinal load of the removable module, it is taken into account that it is subjected to a vertical load  $P_v$  from the transported cargo, as well as a longitudinal load  $P_l$  (Fig. 6).

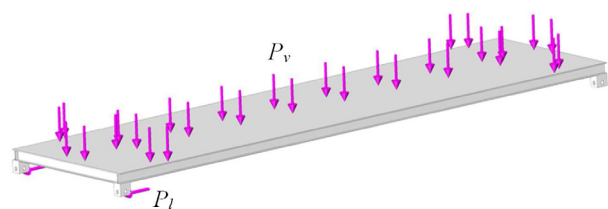

Fig. 6. Design diagram of the removable module

In this case, the longitudinal load  $P_l$  was applied to the fitting stops leading in the direction of movement.

## 5. Results of the scientific substantiation of the situational adaptation of the flat car, model 13-7024, to the transportation of strategic cargo

### 5.1. Determining parameters for the structural components of a removable module

According to the calculation scheme shown in Fig. 4, the value of the bending moments that occur in the cross section of the removable module was obtained (Fig. 7). In this case, “stretching” is shown in orange, and “compression” is shown in blue.

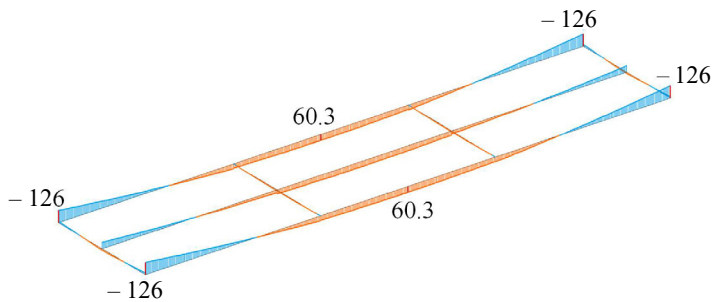

Fig. 7. Diagram of bending moments acting in the cross-section of a removable module (kN·m)

The maximum value of the bending moment occurs in the corner parts of the removable module and is 126 kN·m. In the rods of the middle span of the removable module, the bending moment is equal to 60.3 kN·m.

The execution profile of the removable module is determined by the maximum value of the bending moment. The calculation was performed according to the dependence from [22, 23]:

$$W = \frac{M}{[\sigma]}, \tag{1}$$

where  $M$  is the value of the bending moment acting in the cross-section of the removable module;  $[\sigma]$  is the allowable stresses of the material of the detachable module.

On the basis of our calculations, provided that the removable module is made of 09G2S steel, the value of  $W \approx 400 \text{ cm}^3$  was obtained. According to the obtained value of the moment of resistance, channel No. 30 was chosen as the profile of the frame.

To determine the thickness of the sheets that make up the module, the classical dependence of the Bubnov-Galyorkin method was used. In accordance with it, under the condition of the action of a uniformly distributed load  $P$  on the sheet and the known material of execution, its thickness is determined as:

$$\delta = \sqrt{\frac{D \cdot (b^2 + \mu \cdot a^2) \cdot a^2 \cdot b^2}{\sigma \cdot (a^2 + b^2)^2}}, \tag{2}$$

where  $a, b$  are, respectively, the width and height of the sheet;  $\mu$  is Poisson's ratio;  $\sigma$  is the permissible stresses of the material of the sheet.

With:

$$D = P \cdot \frac{96}{\pi^4}. \tag{3}$$

With the value of  $a=2.7 \text{ m}$  and  $b=12.228 \text{ m}$ , as well as the physical and mechanical properties of low-alloy steel of the 09G2S brand, the value of  $\delta=5.25 \text{ mm}$  was obtained. When calculating, the maximum possible loading of the removable module is taken into account. That is, if two modules are placed on the flat car, then the load on one will be equal to half of the carrying capacity of the flat car.

Taking into account the obtained parameters of the structural components of the removable module, its strength under static load was calculated.

The calculation results are shown in Fig. 8–10. It was established that the maximum stresses occur in the corner parts of the removable module and amount to 165.8 MPa (Fig. 8). These stress values are 21 % lower than the allowable ones. A stress of 210 MPa was accepted as permissible in accordance with DSTU 7598:2014. Freight cars. General requirements for calculations and design of new and modernized cars of 1520 mm gauge (non-self-propelled). This document has an international analog: "EN 12663-2. Railroad applications – structural requirements of railroad vehicle bodies – Part 2: Freight cars. B., 2010. 54 p."

The most loaded zones of the removable module are its corner part and the middle zones of the longitudinal beams of the frame (Fig. 9). The maximum movements occur in the middle part of the removable module and are equal to 8.66 mm (Fig. 10).

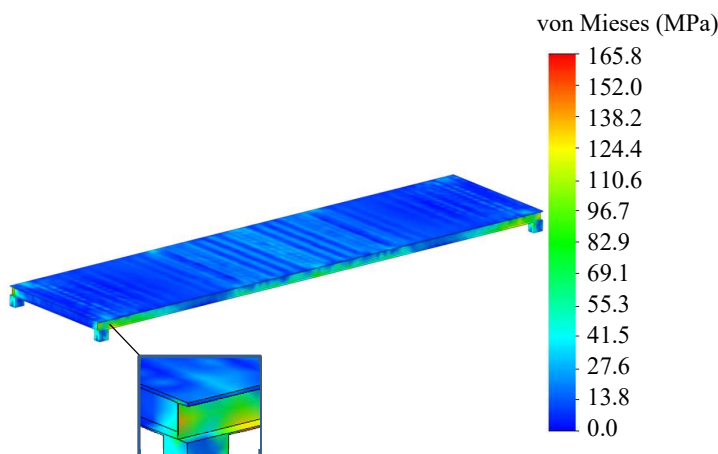

Fig. 8. The stressed state of the removable module

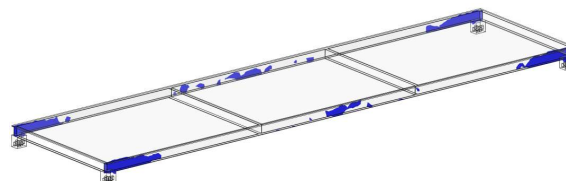

Fig. 9. The most loaded areas of the removable module

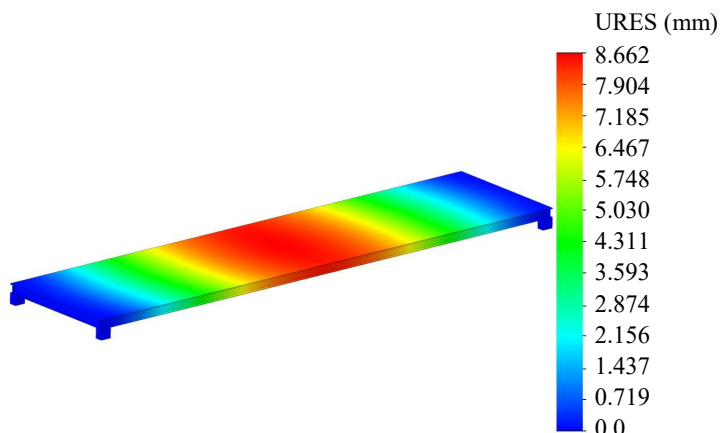

Fig. 10. Movement in nodes of the removable module

Since the attachment of the removable module takes place by the fittings, and the load is applied on the horizontal



surface, then there is exactly such a distribution of the movement fields relative to its structure.

**5.2. Studying the dynamic load and strength of the removable module when it receives vertical loads**

Mathematical modeling was carried out to study the vertical load of the removable module in the vertical plane. It is taken into account that two removable modules are placed on a flat car that moves along the joint unevenness. In this case, the removable modules are loaded with a conditional load using their full load capacity. It is taken into account that the dynamic system is formed by three bodies: the supporting structure of the flat car on which two removable modules with cargo are placed, as well as two bogies. The calculation scheme is shown in Fig. 11.

It is assumed that the flat car moves over the joint unevenness of the track, which has elastic-dissipative properties. Track reactions are proportional to both its deformations and the speed of these deformations. When carrying out calculations, it is taken into account that the supporting structure of the flat car rests on model 18-100 bogies.

Taking this into account, the system of differential equations of motion of the flat car takes the form [12]:

$$\begin{cases} M_1 \cdot \ddot{q}_1 + C_{1,1} \cdot \dot{q}_1 + C_{1,2} \cdot \dot{q}_2 + C_{1,3} \cdot \dot{q}_3 = \\ = -F_{fr} \cdot (\text{sign}(\delta_1) + \text{sign}(\delta_2)), \\ M_2 \cdot \ddot{q}_2 + C_{2,1} \cdot \dot{q}_1 + C_{2,2} \cdot \dot{q}_2 + B_{2,2} \cdot \dot{q}_2 = \\ = F_{fr} \cdot \text{sign}(\delta_1) + k(\eta_1 + \eta_2) + \beta(\dot{\eta}_1 + \dot{\eta}_2), \\ M_3 \cdot \ddot{q}_3 + C_{3,1} \cdot \dot{q}_1 + C_{3,3} \cdot \dot{q}_3 + B_{3,3} \cdot \dot{q}_3 = \\ = F_{fr} \cdot \text{sign}(\delta_2) + k(\eta_3 + \eta_4) + \beta(\dot{\eta}_3 + \dot{\eta}_4), \end{cases} \quad (4)$$

where  $M_1$  – mass of the load-bearing structure of the flat car with cargo;  $M_2, M_3$  – mass, respectively, of the first and second bogie;  $C_{ij}$  – characteristics of the elasticity of the elements of the oscillating system, which are determined by the values of the stiffness coefficients of the springs  $k_B$ ;  $B_{ij}$  – scattering function;  $k$  – track stiffness;  $\beta$  – damping coefficient;  $F_{fr}$  – force of friction in the spring set of the bogie;  $\delta_i$  – deformations of elastic elements of spring suspension;  $\eta_i(t)$  – unevenness of the track.

In system (4), the coordinate  $q_1$  characterizes the vertical movement of the supporting structure of the flat car with cargo;  $q_2, q_3$  – moving bogies.

The solution of the system of differential equations of motion (4) was carried out using the Mathcad software package (USA) [24, 25]. The vector of initial conditions has the following form: the initial movement of the supporting structure with the load is 0.004 m, the speed is 0; for bogies, respectively, 0.003 m and 0 [26]. The calculation results are shown in Fig. 12.

Analyzing Fig. 12, it can be concluded that the maximum acceleration acting on the supporting structure of the flat car with cargo is 1.46 m/s<sup>2</sup> (0.1 g). This acceleration value corresponds to the excellent movement of the flat car.

The obtained acceleration value is taken into account when calculating the strength of the removable module. The calculation results are shown in Fig. 13, 14. The maximum stresses occur in the corner parts of the removable module and amount to 179.3 MPa (Fig. 13), which is 14.6 % lower than permissible.

The maximum displacements are recorded in the middle part of the removable module and amount to 8.9 mm (Fig. 14).

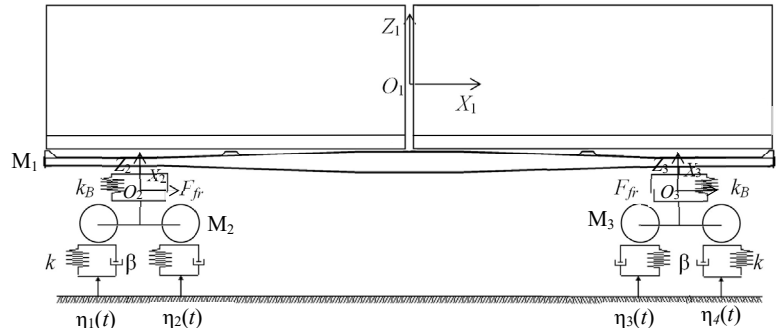

Fig. 11. Calculation diagram of a flat car with removable modules

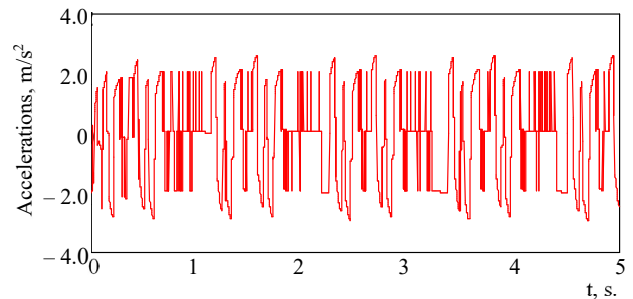

Fig. 12. Accelerations acting on the load-bearing structure of the flat car with cargo

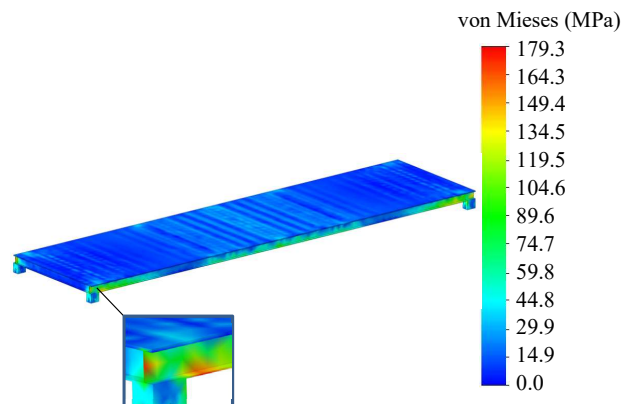

Fig. 13. Stressed state of the removable module under its vertical load

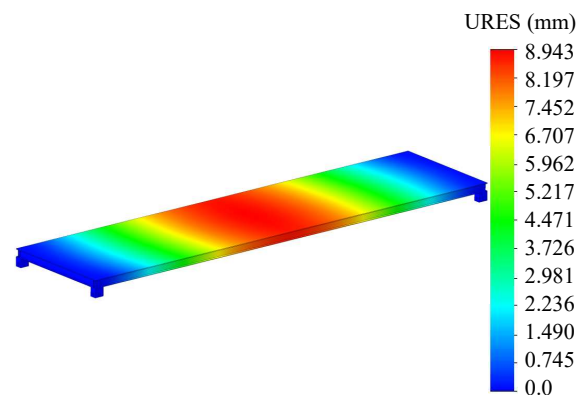

Fig. 14. Movement in the nodes of the removable module when it is vertically loaded

The distribution of displacement fields relative to the structure of the removable module has the same explanation as for the case of its static loading.

### 5.3. Studying the dynamic load and strength of the removable module when it receives longitudinal loads

To study the longitudinal loading of the removable module, mathematical modeling was carried out under the conditions of the movement mode of the flat car in the train – “jerk” (calculation mode III). The calculation scheme of the flat car is shown in Fig. 15.

The system of differential equations of motion of a flat car takes the form [18]

$$\begin{cases} \left( M_{FC} + 2m_B + \frac{n \cdot I_W}{r^2} \right) \cdot \ddot{x} + (M_{FC} \cdot h) \cdot \ddot{\varphi} = P, \\ I_{FC} \cdot \ddot{\varphi} + (M_{FC} \cdot h) \cdot \ddot{x} - g \cdot \varphi \cdot (M_{FC} \cdot h) = \\ = l \cdot F_{fr} (\text{sign} \dot{\Delta}_1 - \text{sign} \dot{\Delta}_2) + l (k_B \cdot \Delta_1 - k_B \cdot \Delta_2), \\ M_{FC} \cdot \ddot{z} = k_B \cdot \Delta_1 + k_B \cdot \Delta_2 - F_{fr} (\text{sign} \dot{\Delta}_1 + \text{sign} \dot{\Delta}_2), \end{cases} \quad (5)$$

$$\Delta_1 = z - l \cdot \varphi; \Delta_2 = z + l \cdot \varphi, \quad (6)$$

where  $M_{FC}$  is the mass of the supporting structure of the flat car with cargo;  $I_{FC}$  is the moment of inertia of the flat car with the load relative to the longitudinal axis;  $P$  is the magnitude of the longitudinal force acting on the car coupling of the flat car;  $m_B$  is the bogie mass;  $I_W$  is the moment of inertia of the wheelset;  $r$  is the radius of the average worn wheel;  $n$  is the number of bogie axles;  $l$  is the half of the base of the flat car;  $F_{fr}$  is the absolute value of the dry friction force in the spring set;  $k_B$  is the stiffness of the springs of the spring suspension of bogies;  $x, \varphi, z$  – coordinates corresponding to the longitudinal, angular relative to the transverse axis and vertical movement of the flat car, respectively.

Based on our calculations, with initial conditions close to zero, the maximum accelerations acting on the supporting structure of the flat car amounted to about  $24 \text{ m/s}^2$  (0.24 g). These accelerations were taken into account when determining the strength of the removable module under the condition of its longitudinal load.

The calculation results showed that the maximum stresses occur in the corner parts of the removable module from the side of the longitudinal load and amount to 184.6 MPa (Fig. 16). The resulting stresses are 12 % lower than permissible.

The maximum displacements take place in the middle part of the module and are equal to 9.1 mm (Fig. 17).

This distribution of displacement fields can be explained again by the fact that the middle part of the removable mod-

ule experiences vertical loading, and its fastening is done by fittings. Therefore, the middle part of the module has the maximum flexibility, and accordingly, the largest displacements occur here.

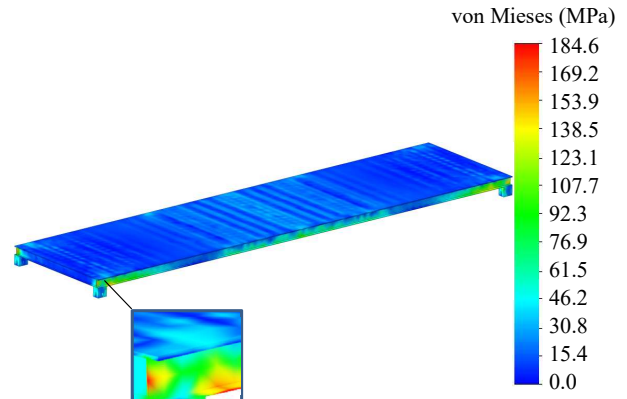

Fig. 16. Stressed state of the removable module under its longitudinal load

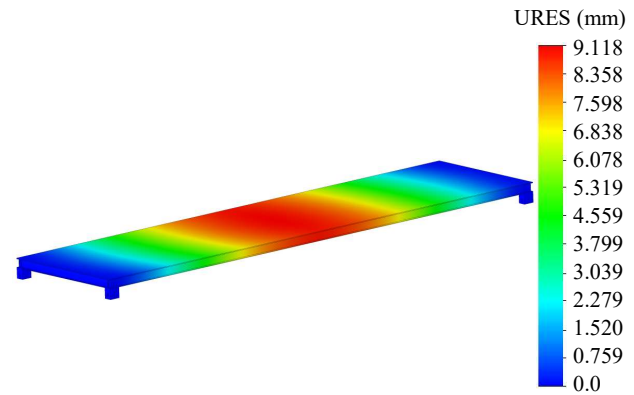

Fig. 17. Movement in the nodes of the removable module under its longitudinal load

## 6. Discussion of results of the scientific substantiation of the situational adaptation of the flat car, model 13-7024, to the transportation of strategic cargo

For the possibility of transportation of strategic cargoes, including military equipment, agricultural machines, etc., the use of a removable module is proposed on the flat car of model 13-7024 (Fig. 2, 3).

In order to determine the parameters of the structural components of the removable module, appropriate calculations were carried out. The results of these calculations made it possible to determine the profile of the frame of the removable module – channel No. 30, as well as the thickness of the sheet that forms the plane for placing the load – 5.25 mm.

To justify the results, calculation was performed on the strength of the removable module under the action of a static load. It was established that the maximum stresses occur in the corner parts of the removable module, but they are 21 % lower than the permissible ones (Fig. 8).

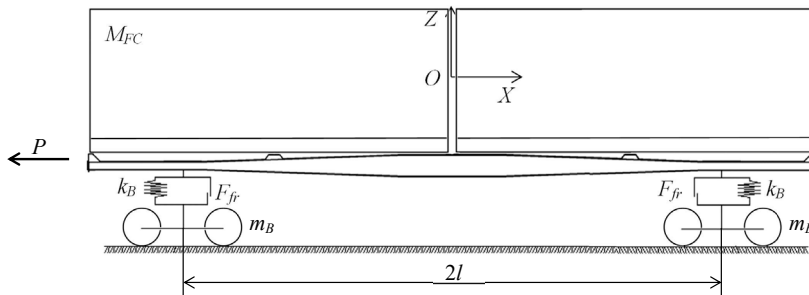

Fig. 15. Design diagram of a flat car with cargo

In addition, as part of the study, the strength of the removable module was determined when it absorbed dynamic loads – vertical and longitudinal. To determine the vertical loads acting on the removable module, modeling of its vertical dynamics was carried out. It was established that the maximum acceleration acting on the supporting structure of the flat car with removable modules is  $1.46 \text{ m/s}^2$  (Fig. 12). This amount of acceleration corresponds to the “excellent” movement of the flat car. The obtained acceleration value is taken into account when calculating the strength of the removable module. The calculation results showed that the maximum stresses occur in the corner parts of the removable module (Fig. 13) and are 14.6 % lower than the allowable ones.

In order to determine the longitudinal accelerations acting on the removable module, simulation of its load was also carried out. In this case, the maximum accelerations acting on the supporting structure of the flat car with removable modules amounted to about  $24 \text{ m/s}^2$ . Taking into account these accelerations in the calculations for the strength of the removable module, it was established that the stresses in its design are 12 % lower than permissible (Fig. 16).

It should be noted that the limitation of this study is that in dynamic calculations the lifting module is considered as an attached mass that completely repeats the trajectory of the flat car movement.

The disadvantage of this research is that when determining the dynamic loads acting on the lifting module, it is taken into account that the supporting structure of the flat car rests on model 18-100 bogies. In further research in this area, a more modern bogie model should be taken into account. However, given that this bogie is the most common in operation, at this stage it is considered as a basic one.

The advantage of this study in comparison with works [8–11] is that we proposed solutions that would contribute to increasing the demand for specialized flat cars in operation. Unlike the designs of removable modules, highlighted in [12, 13], the proposed module is easier to maintain and repair because it does not contain flexible connections. The solutions proposed in the framework of this study will contribute to the possibility of expanding the range of transported goods on specialized designs of flat cars. This will make it possible to improve the efficiency of their operation, in contrast to those structures considered in works [14, 15].

As a further development of this research, it is possible to note the need to determine the loading of the removable module under over-normalized operating modes. Such regimes include the presence of the removable module's own degree of freedom when transported by flat cars, the load when moving as part of combined trains on railroad ferries, etc. It is also advisable to consider the possibility of introducing energy-absorbing components into the design of the removable module [27, 28]. This would contribute to reducing its dynamic load during operational modes and improving durability.

The results of our research will contribute to devising the recommendations for improving the efficiency of flat cars operation through their situational adaptation to the transportation of strategic cargoes. In addition, the results could prove useful for designing modern structures of modular vehicles.

---

## 7. Conclusions

---

1. Parameters for the structural components of a removable module for the situational adaptation of the flat car to the transportation of strategic cargoes have been determined. Channel No. 30 was chosen as the profile of the frame of the removable module. The thickness of the sheet that forms the plane for placing the load was 5.25 mm. Calculation of the strength of the removable module under static load showed that the maximum stresses occur in its corner parts and amount to 165.8 MPa, but they are 21 % lower than permissible. The maximum movements occur in the middle part of the removable module and are equal to 8.66 mm.

2. The dynamic loading and strength of the removable module when it receives vertical loads were studied. It was established that the maximum acceleration that acts on the removable module placed on the flat car during its movement along a contact bump is  $1.46 \text{ m/s}^2$  (0.1g). This amount of acceleration corresponds to the “excellent” movement of the flat car. Calculation of the strength of the removable module showed that the maximum stresses occur in its corner parts and amount to 179.3 MPa. The resulting stresses are 14.6 % lower than permissible. The maximum movements recorded in the middle part of the removable module are 8.9 mm.

3. The dynamic loading and strength of the removable module when it receives longitudinal loads were studied. The maximum longitudinal accelerations acting on the supporting structure of the removable module placed on the flat car were about  $24 \text{ m/s}^2$  (0.24g). The results of calculation of the strength of the removable module showed that the maximum stresses occur in the corner parts of the removable module from the side of the longitudinal load and amount to 184.6 MPa. It should be noted that the obtained stresses are 12 % lower than permissible. The maximum movements take place in the middle part of the module and are equal to 9.1 mm.

---

## Conflicts of interest

---

The authors declare that they have no conflicts of interest in relation to the current study, including financial, personal, authorship, or any other, that could affect the study and the results reported in this paper.

---

## Funding

---

The study was conducted without financial support.

---

## Data availability

---

All data are available in the main text of the manuscript.

---

## Use of artificial intelligence

---

The authors confirm that they did not use artificial intelligence technologies when creating the current work.

## References

1. Rybicka, I., Caban, J., Vrabel, J., Sarkan, B., Stopka, O., Miształ, W. (2018). Analysis of the safety systems damage on the example of a suburban transport enterprise. 2018 XI International Science-Technical Conference Automotive Safety. <https://doi.org/10.1109/autosafe.2018.8373323>
2. Dižo, J. (2016). Analysis of a Goods Wagon Running on a Railway Test Track. *Manufacturing Technology*, 16 (4), 667–672. <https://doi.org/10.21062/ujep/x.2016/a/1213-2489/mt/16/4/667>
3. Dižo, J., Blatnický, M., Steišūnas, S., Skočilasová, B. (2018). Assessment of a rail vehicle running with the damaged wheel on a ride comfort for passengers. *MATEC Web of Conferences*, 157, 03004. <https://doi.org/10.1051/mateconf/201815703004>
4. Dizo, J., Blatnický, M., Harusinec, J., Falendysh, A. (2018). Modification and analyses of structural properties of a goods wagon bogie frame. *Diagnostyka*, 20 (1), 41–48. <https://doi.org/10.29354/diag/99853>
5. Caban, J., Nieoczym, A., Gardyński, L. (2021). Strength analysis of a container semi-truck frame. *Engineering Failure Analysis*, 127, 105487. <https://doi.org/10.1016/j.engfailanal.2021.105487>
6. Suprianto, T., Syaifudin, A., Pamungkas, L. W., Ariatedja, J. B., Farid, A. R. (2023). Effect of Fluctuating Load on Fatigue of PPCW Flat Wagon. *The International Journal of Mechanical Engineering and Sciences*, 7 (1), 26. <https://doi.org/10.12962/j25807471.v7i1.14354>
7. Krason, W., Niezgodna, T. (2014). FE numerical tests of railway wagon for intermodal transport according to PN-EU standards. *Bulletin of the Polish Academy of Sciences Technical Sciences*, 62 (4), 843–851. <https://doi.org/10.2478/bpasts-2014-0093>
8. Fabian, P., Gerlici, J., Masek, J., Marton, P. (2013). Versatile, Efficient and Long Wagon for Intermodal Transport in Europe. *Communications - Scientific Letters of the University of Zilina*, 15 (2), 118–123. <https://doi.org/10.26552/com.c.2013.2.118-123>
9. Šťastniak, P., Kurčík, P., Pavlík, A. (2018). Design of a new railway wagon for intermodal transport with the adaptable loading platform. *MATEC Web of Conferences*, 235, 00030. <https://doi.org/10.1051/mateconf/201823500030>
10. Kel'rich, M., Fedosov-Nikonov, D. (2016). The strength research of the long-wheelbase flatcar construction. *Visnyk Skhidnoukrainskoho Natsionalnoho universytetu imeni Volodymyra Dalia*, 1 (225), 90–94. Available at: [http://nbuv.gov.ua/UJRN/VISUNU\\_2016\\_1\\_19](http://nbuv.gov.ua/UJRN/VISUNU_2016_1_19)
11. Das, A., Agarwal, G. (2020). Investigation of Torsional Stability and Camber Test on a Meter Gauge Flat Wagon. *Advances in Fluid Mechanics and Solid Mechanics*, 271–280. [https://doi.org/10.1007/978-981-15-0772-4\\_24](https://doi.org/10.1007/978-981-15-0772-4_24)
12. Vatulia, G., Lovska, A., Pavliuchenkov, M., Nerubatskyi, V., Okorokov, A., Hordiienko, D. et al. (2022). Determining patterns of vertical load on the prototype of a removable module for long-size cargoes. *Eastern-European Journal of Enterprise Technologies*, 6 (7 (120)), 21–29. <https://doi.org/10.15587/1729-4061.2022.266855>
13. Panchenko, S., Gerlici, J., Vatulia, G., Lovska, A., Pavliuchenkov, M., Kravchenko, K. (2022). The Analysis of the Loading and the Strength of the FLAT RACK Removable Module with Viscoelastic Bonds in the Fittings. *Applied Sciences*, 13 (1), 79. <https://doi.org/10.3390/app13010079>
14. Nandan, S., Trivedi, R., Kant, S., Ahmad, J., Maniraj, M. (2020). Design, analysis and prototype development of railway wagons on different loading conditions. *International Journal of Engineering Applied Sciences and Technology*, 04 (10), 122–129. <https://doi.org/10.33564/ijeast.2020.v04i10.023>
15. Stoilov, V., Simić, G., Purgić, S., Milković, D., Slavchev, S., Radulovi, S., Maznichki, V. (2019). Comparative analysis of the results of theoretical and experimental studies of freight wagon Sdggmrss-twin. *IOP Conference Series: Materials Science and Engineering*, 664 (1), 012026. <https://doi.org/10.1088/1757-899x/664/1/012026>
16. Barabash, M. S., Soroka, M. M., Surianinov, M. H. (2018). *Nelineйна budivselna mekhanika z PK Lira – SAPR*. Odesa: Ekolohiia, 248.
17. Koziar, M. M., Feshchuk, Yu. V., Parfeniuk, O. V. (2018). *Kompiuterna hrafika: SolidWorks*. Kherson: Oldi-plius, 252. Available at: <https://ep3.nuwm.edu.ua/22175/1/Комп%27ютерна%20графіка.pdf>
18. Pustiulha, S. I., Samostian, V. R., Klak, Yu. V. (2018). *Inzhenerna hrafika v SolidWorks*. Lutsk: Vezha, 172. Available at: <https://lib.lntu.edu.ua/sites/default/files/2021-02/Інженерна%20графіка%20в%20SolidWorks.pdf>
19. Nerubatskyi, V. P., Plakhtii, O. A., Hordiienko, D. A., Khoruzhevskiy, H. A. (2023). Study of the energy parameters of the system “solar panels – solar inverter – electric network.” *IOP Conference Series: Earth and Environmental Science*, 1254 (1), 012092. <https://doi.org/10.1088/1755-1315/1254/1/012092>
20. Nerubatskyi, V., Hordiienko, D. (2023). Study of the Influence of Sliding Mode Regulator on Spectrum Higher Harmonics of the SEPIC Converter. 2023 IEEE 5th International Conference on Modern Electrical and Energy System (MEES). <https://doi.org/10.1109/mees61502.2023.10402454>
21. Vatulia, G., Lovska, A., Myamlin, S., Rybin, A., Nerubatskyi, V., Hordiienko, D. (2023). Determining patterns in loading the body of a gondola with side wall cladding made from corrugated sheets under operating modes. *Eastern-European Journal of Enterprise Technologies*, 2 (7 (122)), 6–14. <https://doi.org/10.15587/1729-4061.2023.275547>



22. Shvabiuk, V. I. (2016). *Opir materialiv*. Kyiv: Znannia, 400.
23. Kutsenko, A., Bondar, M., Chausov, M. (2019). *Prykladna mekhanika (opir materialiv)*. Kyiv: Tsentr navchalnoi literatury, 736.
24. Siasiev, A. V. (2007). *Dyferentsialni rivniannia*. Dnipropetrovsk: Vyd-vo DNU, 356.
25. Panchenko, S., Gerlici, J., Vatulia, G., Lovska, A., Rybin, A., Kravchenko, O. (2023). Strength Assessment of an Improved Design of a Tank Container under Operating Conditions. *Communications - Scientific Letters of the University of Zilina*, 25 (3), B186–B193. <https://doi.org/10.26552/com.c.2023.047>
26. Domin, Yu. V., Cherniak, H. Yu. (2003). *Osnovy dynamiky vahoniv*. Kyiv: KUETT, 269.
27. Vatulia, G., Lovska, A., Myamlin, S., Stanovska, I., Holofieieva, M., Horobets, V. et al. (2023). Revealing the effect of structural components made of sandwich panels on loading the container transported by railroad. *Eastern-European Journal of Enterprise Technologies*, 1 (7 (121)), 48–56. <https://doi.org/10.15587/1729-4061.2023.272316>
28. Lovska, A., Stanovska, I., Nerubatskyi, V., Hordiienko, D., Zinchenko, O., Karpenko, N., Semenenko, Y. (2022). Determining features of the stressed state of a passenger car frame with an energy-absorbing material in the girder beam. *Eastern-European Journal of Enterprise Technologies*, 5 (7 (119)), 44–53. <https://doi.org/10.15587/1729-4061.2022.265043>