

S. OSADCHY, N. DEMSKA, YU. OLEKSANDROV, V. NEVLIUDOVA

## RESEARCH OF DIKW AND 5C ARCHITECTURAL MODELS FOR CREATION OF CYBER-PHYSICAL PRODUCTION SYSTEMS WITHIN THE CONCEPT OF INDUSTRY 4.0

The development of cyber-physical production systems is a complex scientific and technical task, therefore the developer needs to determine the requirements, tasks for the system being developed and choose an architectural model for its implementation. In turn, the choice of an architectural model assumes a balance for the set of requirements of persons interested in its development. In a typical case, the development of a specific cyber-physical industrial systems needs to be adapted to the means of implementation, to the realities of its future use, maintenance and evolution. **Subject matter** of this study are architectural models for building complex cyber-physical production systems. **Goal** of this article is a study of architectural models DIKW and 5C, according to the results of the decomposition of which, in the future, it will be possible to carry out a mathematical description of elementary problems of each level and their physical or simulation modeling. To achieve this goal, it is necessary to solve the following **tasks**: analyze the DIKW model; analyze the architectural model 5C; compare the DIKW model and the 5C architectural model, using its structural decomposition into levels, information and command channels with feedback within each structure. The research carried out is based on the methods of decomposition and formalized representation of systems. **Conclusions**: Based on the results of the decomposition at each structural level of the DIKW and 5C models, a decomposition structure was developed, which shows the main differences and general similarities of the models. It was revealed that the 5C model, as a common software shell that combines integrated sensors and actuators, is more suitable for solving problems of developing a cyber-physical production system, and the DIKW interpretation model is more suitable for solving problems of modifying existing systems at enterprises, and the choice of the model itself the development of a cyber-physical production system depends on the requirements of the customer, existing equipment, the level of its automation and the level of project financing.

**Keywords:** Industry 4.0; Smart Manufacturing; Digital Twins; cyber-physical industrial systems; DIKW model; 5C architecture.

### Introduction

With the emergence of new requirements for the production of high-tech products, in the widespread use of digital, network and intelligent technologies, the constant development of integrated production innovations, a necessary condition became the introduction of information technology, which is the main engine for a new industrial revolution.

In particular, the new generation of uninhabited, intelligent production, includes major and profound changes in the philosophy of modern industry, based on the concept of Industry 4.0, proposed by Germany [1-2]. In turn, the United States launched the Advanced Manufacturing Partnership project [3], the United Kingdom put forward the UK Industry 2050 strategy [4]. In addition, France introduced the New Industrial France program [5], Japan proposed the Society 5.0 program [6], and Korea began production under the Innovation 3.0 program [7].

Basically, in these projects, the development of intellectual production is seen as a key tool for creating competitive means of industrial development of large countries around the world. The "Made in China 2025" plan, formerly known as "China Manufacturing 2025" [8], specifically emphasizes the intellectualization of production, based on the in-depth integration of next-generation information technology into industry.

Based on these requirements, within the concept of Industry 4.0, the technology of creation of digital twins (Digital Twins) of technological processes, within the limits of Smart Manufacturing is offered. As a result of the collaboration of theoretical research, a new approach to the realization of production was created, as a synthesis

of cybernetic and physical components - "Cyber-physical production systems" (SPPS).

The growing complexity of production systems requires appropriate management architectures that provide flexible adaptation during their operation.

According to the analysis of problems in the development of complex SPPS [9-12] it is determined that their creation depends primarily on their architectural model, type and type of equipment, parameters of production processes at all stages of the life cycle, which directly affect the structure of information flows, their visualization in the cybernetic component and the implementation of feedback. In essence, the new term, SPPS is an architectural paradigm in which comprehensive sounding technology is a fundamental part [13].

### Problem statement and research purpose

Modern production (enterprise) is a technological system consisting of interconnected horizontally and vertically subsystems. The basis of each complex technological system (TS), in our case, the company, are the production processes that are performed in the relevant departments. The TS of the production unit consists of a set of typical main and auxiliary technological processes and devices controlled by automated control systems (ACS), which include systems designed to control continuous production, automated production lines, complex lines of units and machines, machines with numerical program management [13].

The amount of information that must be received and promptly processed to form effective management influences in modern management systems has grown so

much that it far exceeds the capabilities of one person. Therefore, the management of complex objects is entrusted to a team of people, the quantitative growth of which still does not provide the required quality of object management. There is a critical point when intensive coordination of information within the management system itself is required to coordinate and coordinate individual management influences, to inform some people about the decisions made by other people. Therefore, the main tool for solving modern problems of management of material objects is ACS, in which the main role and creativity of man are combined with the widespread use of modern mathematical methods and automation tools [13].

Currently, a clearly defined 5-layer automation architecture has been formed (fig. 1). Over the past three decades, the evolution of information technology has transformed the world we live in, generating new business models and influencing the industry in such a way that global consumers change their way of consuming [14]. According to observations, companies that do not invest in efficiency, in fact, pose a threat to their survival. Without

efficiency, the company cannot guarantee the level of quality, accuracy and demand required for the current market. In this regard, the structure of Industry 4.0 dictates new directions for creating efficient and smart production [14].

Due to the development of network technologies, 5 layers may not be needed in the future. These technologies allow to connect into a single corporate network numerous and remote computer, which are used to control and analyze material, energy and financial flows in the production of products, as well as TP management, which facilitated the transition to SPPS. In these systems with the help of very complex software the whole complex of tasks on management of activity of the enterprise, including tasks of the account, planning, management of TP, etc. is jointly solved.

Thus, the main action of SPPS, in contrast to the classic ACS representation, is that the sensors transmit data directly to the cloud. Services (such as production planning) automatically subscribe to the necessary data in real time - a vision of cyber physical systems (fig. 2).

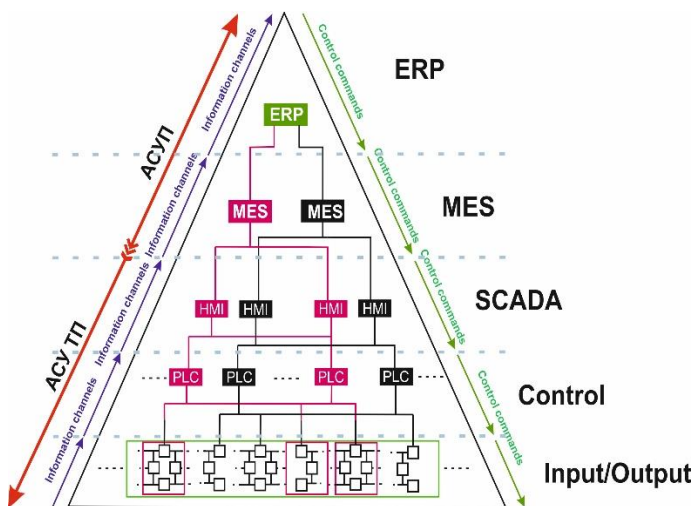

**Fig. 1.** Classical construction of production process control (DIKW model)

At present, there is no single approach to the development of SPPS and for each company it is an individual task. Considering the existing modern approaches to the production of electronic devices, we can see that they are mainly streaming, flexible and discrete. This is due to the fact that most global brands do not have their own production of components, and order their production in contract electronics companies (Jable, etc.) as a result of which production lines have a short life cycle, and readjustment and reprogramming of each unit takes a lot a lot of time, compared to the lifetime of this line [15].

One of the pioneers in this field is Festo, which offers new approaches to automation of control processes based on the use of SPPS and IoT technologies. This approach is based on the concept of a single cloud structure "Festo Cloud", to which, using an industrial gateway IoT, connect mechatronic devices, which for the implementation of the process control process can be

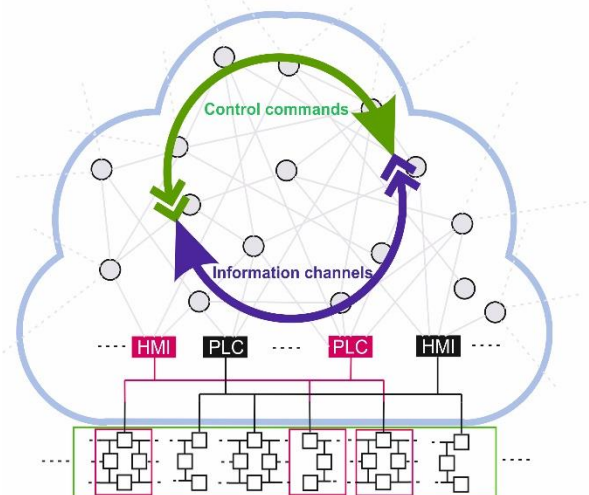

**Fig. 2.** SPPS-based process control

combined into "Automation Platforms", with a single information support.

When complicating or simplifying the technological process of manufacturing products in the production line are added to the actuator and mechatronic module, which controls it, and is an integral part of the overall "Automation Platform". This solution allows to reduce the time of reconfiguration of the production line for the production of new products, as well as to implement the connection of individual equipment or shops without interfering with the control system of the machine [15]. SPPS provides tools to overcome complexity and flexibility, but integrating component data with existing management systems remains a challenge.

The disadvantages of the classical construction of the process of production process management (model DIKW) and the main advantages of the implementation of cyber-physical systems are given in table 1.

**Table 1.** Comparative analysis of the construction production processes control

Disadvantages of DIKW	Advantages of SPPS	Explanation
lack of adaptability	advanced information functions at the level of ACS TP	ability to adapt to changes in the external environment
weak dynamism, flexibility	high survivability and reliability of the system in case of failure of its individual elements	ability to respond sensitively to changes in demand, technology, etc.
weak adequacy	adequate diagnostics of technological equipment and tools at the level of ACS TP	constant compliance of the organizational structure with the parameters of the managed system
specialization	timely submission to operational personnel of reliable information on the course of the technological process, the state of equipment and technological controls	restriction and specification of the scope of activities of each management unit
rigid optimality	implementation of particularly complex control and regulation algorithms	establishing rational links between levels and levels of government
poor efficiency	ensuring effective automated control of technological processes in normal, transient and pre-emergency modes of operation, production of products of a given quality and quantity	prevention of irreversible changes in the managed system during decision-making
weak reliability	providing staff with retrospective information in full for analysis, optimization and planning of equipment operation, as well as its repair in real time	guarantee of reliability of information transfer
low efficiency	simplification of technological equipment management by reducing the number of equipment at the level of ACSTP	compliance of maintenance costs with the organization's capabilities
lack of simplicity	optimal communication (interface) "man-machine"	ease for staff to adapt to this form of management

According to the results of the analysis, it can be determined that the advantages of SPPS are the implementation of an automated cycle of creating a new product from pre-design research to production of a serial sample, while providing work at all stages - from research to production - based on without material transfer of information between the components of the systems of this cycle using local area networks.

Thus, to create a system that works with knowledge and is able to some extent replace the expert or help him in decision-making in production management, it is necessary to seek to lay in the architecture of the system the ability to implement these functions.

The development of architectural models should also use the accumulated experience of successful developments, especially experience embedded in architectural styles, each of which is a sample of common standard solutions, and integrates significant solutions based on the principles of rationality. Significant decisions and forms of their integration must be rationally presented and justified and not only declared, but also have a justification "Why they were preferred among the alternatives" [16].

The development of SPPS is a complex scientific and technical task, so the developer needs to determine the requirements, tasks for the developed system and choose the architectural model of its implementation. In turn, the choice of architectural model involves maintaining a balance for the set of requirements of persons interested in its development. Typically, the development of a particular SPPS requires adaptation to the realities of the funds and funds allocated for development, and to the realities of its future use, taking into account its maintenance and evolution [16].

#### Presentation of the main research material.

The main decisions on the above requirements and adaptation, which includes the construction of a balanced set of requirements, are made when building the SPPS architecture. There is architecture in different volumes: software, hardware, information support; organizational support, enterprises. Thus, the following is an overview of the architectural representations of SPPS, taking into account its representation in the context of "enterprise".

Analyzing publications: [14, 17], which consider ANSI ISA 95, 5C and 8C models; [18], where the model 8C is proposed on the basis of the model 5C and [19], which is dedicated to the development of the integration model CPPS-IoE-5C - it can be seen that they are descriptive, which does not allow to compare a model when choosing an architecture for developed by SPPS.

Therefore, in the framework of this study, a comparative analysis of the DIKW model with the architectural model 5C will be conducted, based on the results of their decomposition at each structural level.

The DIKW model (also known as the DIKW pyramid, the DIKW hierarchy, the data pyramid, the knowledge hierarchy) is a hierarchical model for representing the flow of data through information, knowledge, and wisdom. The name of the DIKW model is an abbreviation of the first letters "Data, Information, Knowledge, Wisdom" which description is given in fig. 3.

Data is a set of discrete facts about events obtained as input from processes. The data mainly consists of symbols or signs representing stimuli or signals that are not useful for processing;

Information is processed data. This is due to the provision of context by the data or through data questions. This usually requires the collection of various data sources and the provision of some value or correspondence to a set

of facts. The information tries to answer the question "Who? Which? When? Where?";

Knowledge is a more derived form of data. It consists of concepts, experiences, ideas, values and judgments of people with a clear reference to information. This usually requires information analysis and assists in decision making. Knowledge tries to answer the question "How?";

Wisdom - gives a final understanding of the data. It describes the application of knowledge and provides contextual awareness to form a strong sound judgment. Using wisdom allows an organization to manage its strategy and growth in a competitive marketplace. Wisdom tries to answer the question "Why?".

With the advent of Industry 4.0 concepts and the

concept of Smart Manufacturing, the DIKW model received the following iteration of hierarchical levels, which is presented in fig. 4 and is formed on the principle of "bottom to top".

At the first field level is the interaction with the production process using sensors and actuators; at the control level is the regulation and control of actuators using programmable logic controllers (PLC); the level of the technological line (production level) (actually the level of the production process) performs the function of control and monitoring of the technological process of production; operations level is designed for production planning, quality management, etc. ; enterprise level planning provides order management, processing, general production planning, etc.

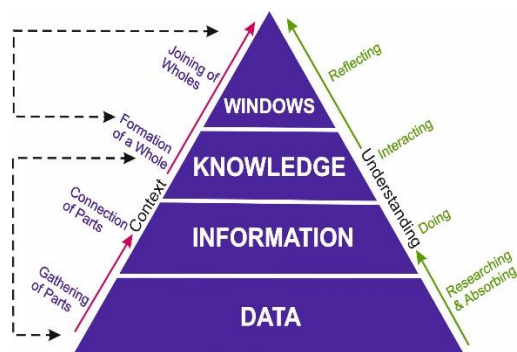

Fig. 3. Classic representation of the DIKW model

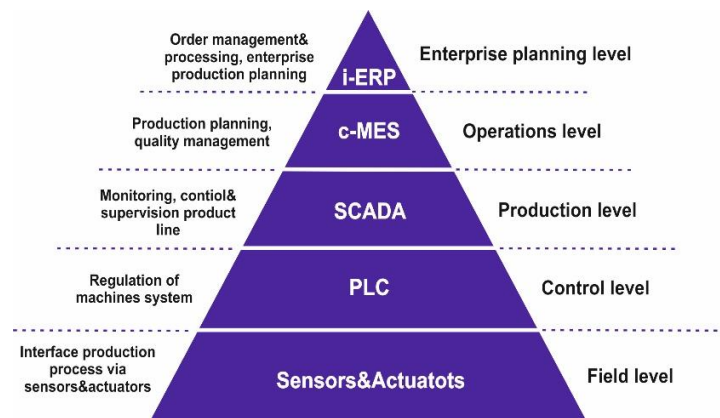

Fig. 4. Interpretation of the DIKW model in terms of its application in Smart Manufacturing

In 2015, [19] proposed an architectural model 5C, presented, which according to the authors consists of the following levels of "Smart Connection", "Data-to-

Information Conversion", "Cyber", "Cognition" and "Configuration". A general view of the CPPS 5C architecture is presented in fig. 5.

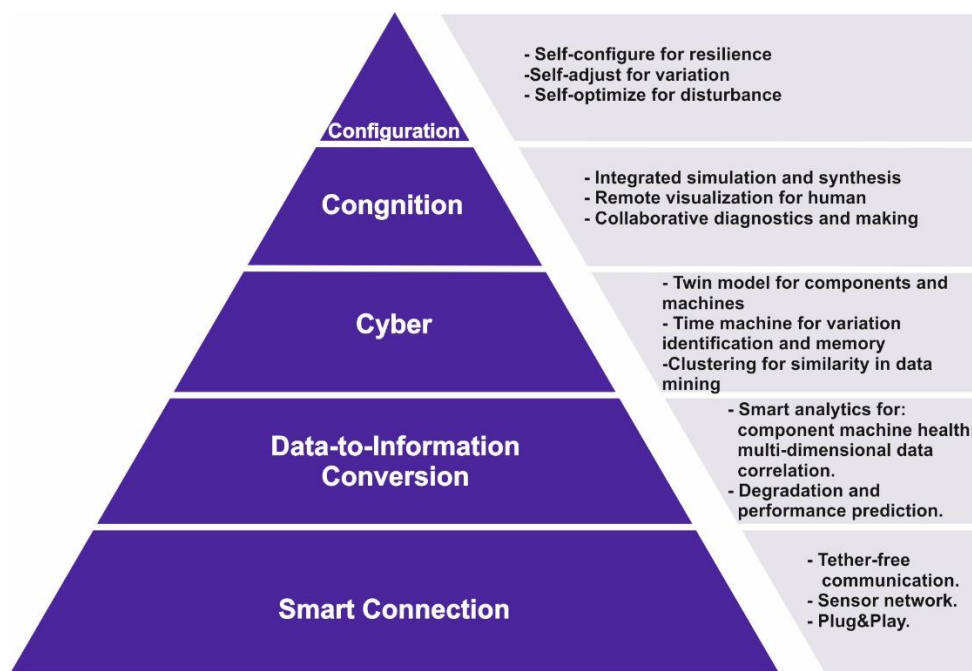

Fig. 5. Architectural model 5C

At the first level of "Smart Connection" machines and their components are used to obtain accurate and reliable data in the first step of SPPS management for Smart Manufacturing.

Smart connection – the level of data acquisition using sensors used to collect various parameters of the technological process of production of products in real time. IIoT technologies used for data transmission and control according to selected protocols in accordance with the specification of the selected equipment.

Data-to-information conversion – is designed to convert the received data into information. This level is considered from the point of view of the fact that some devices can implement functions of forecasting and monitoring of equipment wear – which introduces the concept of "intelligence" quality.

Cyber – a level that is given the role of the main information center, which collects an array of information from the equipment to the industrial network. According to the received data, productivity of one equipment is compared and ranked among all identical types of the equipment which are in an industrial network.

Cognition – designed to provide analytical information directly to operators for production decisions. This level allows remote and joint diagnosis and decision making in the production environment;

Configuration – returns feedback from the "Cyber" level to the "Smart Connection", i.e. performs dispatch control, which allows you to make equipment with self-configuration, self-tuning and self-optimization.

For comparative analysis of architectural models 5C and interpretive model DIKW, in terms of its application in Smart Manufacturing, it is proposed to decompose it:

- by levels;
- by the areas of information flows about the state and management teams;
- by the number of feedbacks - types and kinds of network protocols used to create channels for transmitting information between levels.

Based on the above parameters of the decomposition of the model 5C developed [14] (fig. 5) and the interpretation model DIKW (fig. 4), for the convenience of information perception developed a decomposition structure, which is presented in fig. 6.

As can be seen from the above structure (fig. 6), both models at the first level Smart Connection and Field level consist of sensors and actuators that interact with the 0 level – the technological object of control, here is information about the state of the object from the lower level transmitted to the upper level.

The information received from the sensors is transmitted to the *Control level*, which contains the *Programmable Logic Controller (PLC)*, where the regulation and control of actuators.

In contrast to the DIKW model, the 5C model proposes a solution to place at the *Data-to-Information Conversion* level two parallel *Configurations*, which act as feedback from the *Cyber* level to the *Smart Connection* level [14], which allows to make equipment with self-configuration, self-tuning and self-optimization. As a

result of this combination, the decomposition structure of the 5C model becomes one level smaller.

Considering the 5C model, we can see that the Cyber layer acts as the main information center, which collects an array of information from the equipment and the data checks its performance and ranking among the same type that are in the network.

Then the information comes to level 4 - *Cognition*, which combines a single set (modules) of software *Human-machine interface (HMI)* and *Graphical User Interface (GUI)*, which are designed to provide analytical information directly to operators or software robots. Similarly, this level allows remote and joint diagnosis and decision making in the production environment.

In contrast to level 4 Cognition in model C5, the functions listed in model DIKW are represented from level 3 *Supervisory Control And Data Acquisition (SCADA)* through level *Manufacturing Execution System (MES)* to level 5 *Enterprise Resource Planning (ERP)*.

At the MES and ERP levels, the content of information is transmitted by means of syntax or purely formal, structural properties of language, thus the type of message uniquely determines its content. SPPS has a semiotic structure, i.e. the full-fledged linguistic nature of information connections. In this case, the uniqueness of the transmission is violated and in the process of signal processing by the successor is a fundamentally new technology – the interpretation of the received message. This means that the reaction of the system or receiving element will be far from unambiguous, it depends on the content, which to some extent is inherent in the signal. Such systems must have not only a much larger information reserve, but also the ability to distinguish meaningful elements. Therefore, in order to achieve the information integral SPPS that is being developed, to determine the structure at an early stage, which will further allow to recognize and identify information links and their characteristics.

In most cases, at levels 3-5 of the DIKW model, software products from different developers are used to implement their functions, which limits their adaptability to the problem to be solved, and also contains only a general set of solutions that are suitable for a particular field of production.

After all, the most difficult to balance non-functional requirements are those responsible for its quality and/or the quality of the development process. In the search for balance should take into account the fact that: the end user is interested in intuitive and predictable behavior when interacting with it, in such quality characteristics as "convenience", "intelligibility" and "ability to learn"; the system administrator is interested in intuitive tools for his work, including tools that help in monitoring the state of SPPS and its behavior; the marketer is interested in winning functions in the market of related systems and the price; the buyer is interested in the price, stability of work and the plan of delivery and commissioning;

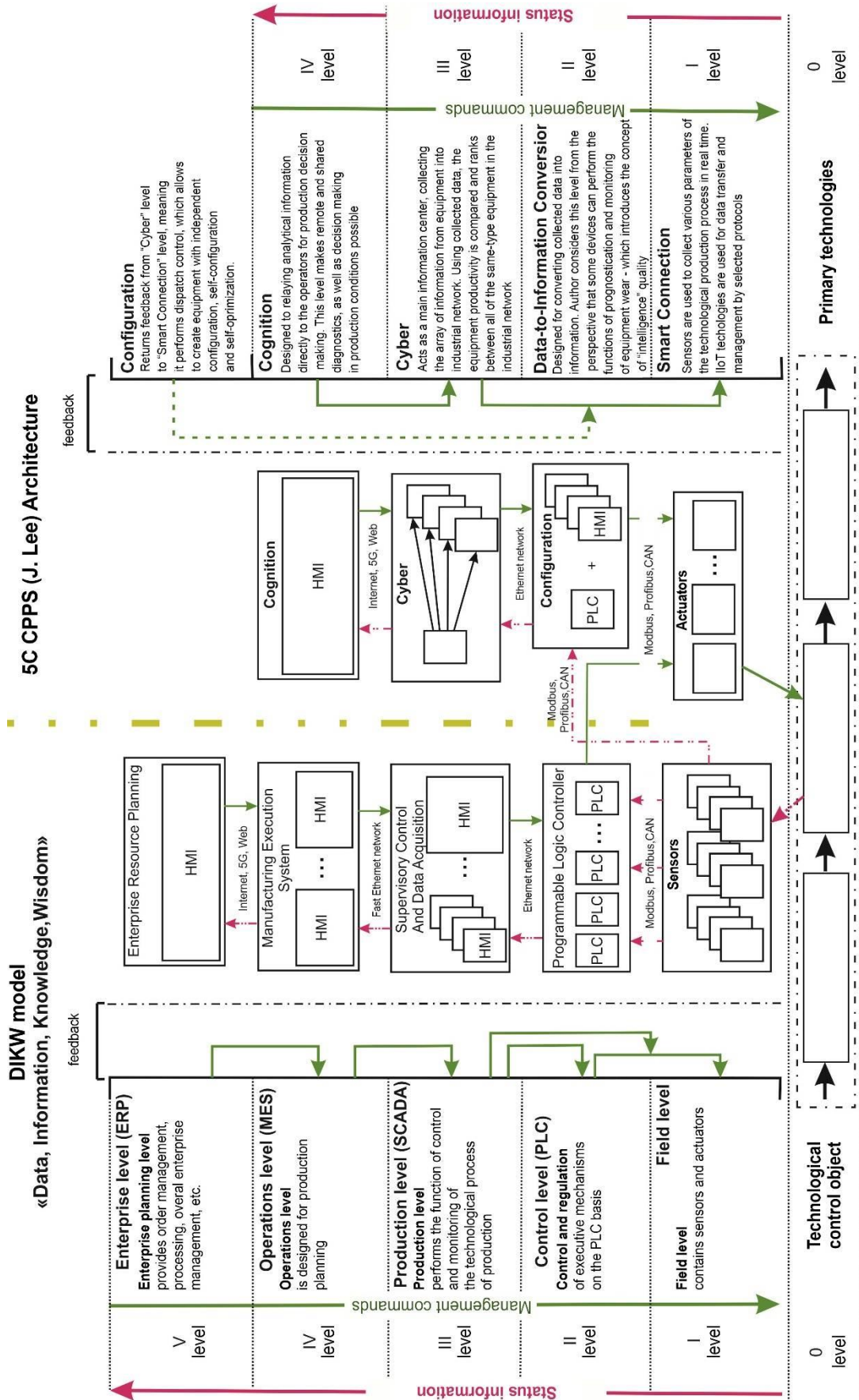

Fig. 6. Decomposition structure of comparable architectural models DIKW and 5C

the developer is interested in clear and consistent requirements for the system, as well as in the possibility of using a simple approach to design [20]; the project manager is interested in the predictability of the deployment of works and their results, in the tracing of the project, action plan, productive means, available resources, primarily financial resources; the person responsible for maintenance is interested in the clarity of the system and the solutions invested in its development, as well as in the documentation and ease of modification.

### Conclusions

It is worth noting that the solution proposed by Festo is currently the idea of production of the future (a prototype plant in Scharnhausen) [15]. There are still many questions about creating a methodological, mathematical, functional and algorithmic framework that will describe the interaction of control processes within the system, optimize the choice and number of mechatronic devices, distribute tasks and connections of the cybernetic component, simplify the mechanism of adding and connecting new mechatronic devices to minimize the number of changes to information flows (command and control flows) in existing systems.

The article analyzes the architectural models of DIKW and 5C in terms of their application for the development of cyber physical production systems. For convenience of comparison, the factors on the basis of which the decomposition of their interpretive models was carried out were chosen. On the basis of the performed decomposition the decomposition structure of the DIKW and 5C models was developed, which shows the main differences and general similarities of the models.

The use of the proposed decomposition structure of architectural models will allow to define and outline the purpose and tasks at each level of decomposition, to make a mathematical description of elementary tasks and their physical or simulation modeling, to achieve the main goal of SPPS development.

According to the results of the work, it was concluded that the 5C model, as the only software shell that combines integrated sensors and actuators, is more suitable for solving the problem of SPPS development. In turn, the DIKW interpretation model is more suitable for solving problems of modification of existing systems in enterprises, and the choice of SPPS development model depends on the requirements of the customer, existing equipment, the level of its automation and the level of project financing.

### References

1. Sony, M., Naik, S. (2019), "Key ingredients for evaluating Industry 4.0 readiness for organizations: a literature review", *Benchmarking: An International Journal*, Vol. 27, No. 7, P. 2213–2232. DOI: <https://doi.org/10.1108/BIJ-09-2018-0284>
2. Rossit, D. A., Tohmé, F., Frutos, M. (2019), "Industry 4.0: smart scheduling", *International Journal of Production Research*, No. 57 (12), P. 3802–3813. DOI: <https://doi.org/10.1080/00207543.2018.1504248>
3. Holdren, J. P., Power, T., Tassej, G., Ratcliff, A., Christodoulou, L. (2012), "A National strategic plan for advanced manufacturing", *US National Science and Technology Council*, Washington, DC., available at :: <http://www.docin.com/p-391856652.html>
4. Foresight, U. K. (2013), *The future of manufacturing: a new era of opportunity and challenge for the UK*, Summary Report, The Government Office for Science, London, 20 p.
5. Cohen, E. (2007), "Industrial Policies in France: The Old and the New", *Journal of Industry, Competition and Trade*, No. 7, P. 213–227. DOI: <https://doi.org/10.1007/s10842-007-0024-8>
6. Taki, H. (2017), "Towards Technological Innovation of Society 5.0", *Journal-Institute of Electrical Engineers of Japan*, No. 137 (5), P. 275–275. DOI: <https://doi.org/10.1541/ieejjournal.137.275>
7. Moon, H. C., Chung, J. E., Choi, S. B. (2018), "Korea's Manufacturing Innovation 3.0 Initiative", *Journal of Information and Management*, No. 38 (1), P. 26–34. DOI: [https://doi.org/10.20627/jsim.38.1\\_26](https://doi.org/10.20627/jsim.38.1_26)
8. Zhou, J. (2015), "Intelligent manufacturing-main direction of "made in china 2025", *Zhongguo Jixie Gongcheng/China Mechanical Engineering*, No. 26 (17), P. 2273–2284. DOI: <https://doi.org/10.3969/j.issn.1004-132X.2015.17.001>
9. Paulo Leitão, Armando Walter Colombo, Stamatis Karnouskos (2016), "Industrial automation based on cyber-physical systems technologies: Prototype implementations and challenges", *Computers in Industry*, Vol. 81, P. 11–25. DOI: <https://doi.org/10.1016/j.compind.2015.08.004>
10. Huang, G., Chen, J., Khojasteh, Y. (2021), "A cyber-physical system deployment based on pull strategies for one-of-a-kind production with limited resources", *Journal of Intelligent Manufacturing*, No. 32 (2), P. 579–596. DOI: <https://doi.org/10.1007/s10845-020-01589-8>
11. Stefano Zanero (2017), "Cyber-Physical Systems", *Computer*, Vol. 50, Issue 4, P. 14–16. DOI: <https://doi.org/10.1109/MC.2017.105>
12. Mosterman, P. J., Zander, J. (2016), "Cyber-physical systems challenges: a needs analysis for collaborating embedded software systems", *Software & Systems Modeling*, No. 15, P. 5–16. DOI: <https://doi.org/10.1007/s10270-015-0469-x>
13. Nevliudov, I., Yevsieiev, V., Demska, N., Novoselov, S. (2020), "Development of a software module for operational dispatch control of production based on cyber-physical control systems", *Innovative Technologies and Scientific Solutions for Industries*, No. 4 (14), P. 155–168. DOI: <https://doi.org/10.30837/ITSSI.2020.14.155>
14. Lee, J., Jin, C., Bagheri, B. (2017), "Cyber physical systems for predictive production systems", *Production Engineering*, Vol. 11, P. 155–165. DOI: <https://doi.org/10.1007/s11740-017-0729-4>
15. Sergeychik, A. (2019), "A step towards Industry 4.0: Festo devices for modern production" ["Shag navstrechu "Industrii 4.0": ustroystva Festo dlya organizatsii sovremennogo proizvodstva"], *Control Engineering Rossiya*, No. 4 (82), P. 38–41.

16. Sosnin, P. I. (2008), *Architectural modeling of automated systems* [Архітектурное моделирование автоматизированной системы], Ul'yanovsk, UIGTU, 147 p.
17. Lee, J., Davari, H., Singh, J., Pandhare, V. (2018), "Industrial artificial intelligence for industry 4.0-based manufacturing systems", *Manufacturing Letters*, No. 18, P. 20–23. DOI: <https://doi.org/10.1016/j.mfglet.2018.09.002>
18. Jiang, J. (2018), "An improved cyber-physical systems architecture for industry 4.0 smart factories", *Advances in Mechanical Engineering*, No. 10 (6). DOI: <https://doi.org/10.1177/1687814018784192>
19. Erasmus, J., Vanderfeesten, I., Traganos, K., Keulen, R., Grefen, P. (2020), "The HORSE project: The application of business process management for flexibility in smart manufacturing", *Applied Sciences (Switzerland)*, No. 10 (12). DOI: <https://doi.org/10.3390/APP10124145>
20. Beskorovainyi, V. (2020), "Combined method of ranking options in project decision support systems", *Innovative Technologies and Scientific Solutions for Industries*, No. 4 (14), P. 13–20. DOI: <https://doi.org/10.30837/ITSSI.2020.14.013>

Received 26.02.2021

*Відомості про авторів / Сведения об авторах / About the Authors*

**Осадчий Сергій Іванович** – доктор технічних наук, професор, Центральнокіровоградський національний технічний університет, завідувач кафедри автоматизації виробничих процесів, Кропивницький, Україна; email: [srg2005@ukr.net](mailto:srg2005@ukr.net); ORCID: <https://orcid.org/0000-0002-1811-3594>.

**Осадчий Сергей Иванович** – доктор технических наук, профессор, Центральнокіровоградский национальный технический университет, заведующий кафедрой автоматизации производственных процессов, Кропивницкий, Украина.

**Osadchy Sergei** – Doctor of Sciences (Engineering), Professor, Central Ukrainian National Technical University, Head of the Department of Automation of Production Processes, Kropyvnytskyi, Ukraine.

**Демська Наталія Павлівна** – кандидат технічних наук, Харківський національний університет радіоелектроніки, старший викладач кафедри комп'ютерно-інтегрованих технологій, автоматизації та мехатроніки, Харків, Україна; email: [demska.nataliia@nure.ua](mailto:demska.nataliia@nure.ua); ORCID: <https://orcid.org/0000-0002-9931-9964>.

**Демская Наталья Павловна** – кандидат технических наук, Харьковский национальный университет радиоэлектроники, старший преподаватель кафедры компьютерно-интегрированных технологий, автоматизации и мехатроники, Харьков, Украина.

**Demska Nataliia** – PhD (Engineering Sciences), Kharkiv National University of Radio Electronics, Senior Lecturer of the Department of Computer-Integrated Technologies, Automation and Mechatronics, Kharkiv, Ukraine

**Олександров Юрій Миколайович** – кандидат технічних наук, професор, Харківський національний університет радіоелектроніки, професор кафедри комп'ютерно-інтегрованих технологій, автоматизації та мехатроніки, Харків, Україна; email: [yuriy.oleksandrov@nure.ua](mailto:yuriy.oleksandrov@nure.ua), ORCID: <https://orcid.org/0000-0001-8252-9685>.

**Александров Юрий Николаевич** – кандидат технических наук, профессор, Харьковский национальный университет радиоэлектроники, профессор кафедры компьютерно-интегрированных технологий, автоматизации и мехатроники, Харьков, Украина.

**Oleksandrov Yuriy** – PhD (Engineering Sciences), Professor, Kharkiv National University of Radio Electronics, Professor of the Department of Computer-Integrated Technologies, Automation and Mechatronics, Kharkiv, Ukraine.

**Невлюдова Вікторія Валеріївна** – кандидат технічних наук, доцент, Харківський національний університет радіоелектроніки, доцент кафедри комп'ютерно-інтегрованих технологій, автоматизації та мехатроніки, Харків, Україна; email: [d\\_tapr@nure.ua](mailto:d_tapr@nure.ua), ORCID: <https://orcid.org/0000-0002-1158-5089>.

**Невлюдова Виктория Валерьевна** – кандидат технических наук, доцент, Харьковский национальный университет радиоэлектроники, доцент кафедры компьютерно-интегрированных технологий, автоматизации и мехатроники, Харьков, Украина.

**Nevliudova Viktoriia** – PhD (Engineering Sciences), Associate Professor, Kharkiv National University of Radio Electronics, Associate Professor the Department of Computer-Integrated Technologies, Automation and Mechatronics, Kharkiv, Ukraine.

## ДОСЛІДЖЕННЯ АРХІТЕКТУРНИХ МОДЕЛЕЙ DIKW ТА 5C ДЛЯ СТВОРЕННЯ КІБЕРФІЗИЧНИХ ВИРОБНИЧИХ СИСТЕМ В РАМКАХ КОНЦЕПЦІЇ INDUSTRY 4.0

Розробка кіберфізичної виробничої системи є складною науково-технічною задачею, тому розробнику потрібно визначити вимоги, завдання, що пред'являються до розроблюваної системи і обрати архітектурну модель її реалізації. У свою чергу вибір архітектурної моделі передбачає дотримання балансу для сукупності вимог осіб, зацікавлених в її розробці. У типовому випадку розробка конкретної кіберфізичної виробничої системи потребує адаптації до засобів реалізації, до реалій майбутнього її використання, супровіду і еволюції. **Предметом** даного дослідження є архітектурні моделі побудови складних кіберфізичних виробничих систем. **Метою** даної статті є дослідження



архітектурних моделей DIKW та 5C, за результатами проведення їх декомпозиції на кожному структурному рівні для подальшого проведення математичного опису елементарних завдань кожного рівня і їх фізичного або імітаційного моделювання. Для досягнення поставленої мети необхідне вирішення наступних завдань: провести аналіз моделі DIKW; провести аналіз архітектурної моделі 5C; порівняти модель DIKW і архітектурну модель 5C, за допомогою їх структурної декомпозиції за рівнями, інформаційними і командними каналами зі зворотніми зв'язками всередині кожної структури. Проведені дослідження базуються на методах декомпозиції та формалізованого представлення систем. **Висновки:** за результатами проведення декомпозиції на кожному структурному рівні моделей DIKW і 5C була розроблена декомпозиційна структура, на якій показані основні відмінності і загальні подібності моделей. Виявлено, що модель 5C, як єдина програмна оболонка, яка об'єднує в собі інтегровані датчики і виконавчі пристрої, більше підходить для вирішення завдання розробки кібер-фізичної виробничої системи, а інтерпретаційна модель DIKW більше підходить для рішень задач модифікації існуючих систем на підприємствах, а сам вибір моделі розробки кіберфізичної виробничої системи залежить від вимог замовника, існуючого обладнання, рівня його автоматизації і рівня фінансування проекту.

**Ключові слова:** Industry 4.0; Smart Manufacturing; Digital Twins; кібер-фізичні промислові системи; модель DIKW; архітектура 5C.

## ИССЛЕДОВАНИЕ АРХИТЕКТУРНЫХ МОДЕЛЕЙ DIKW И 5C ДЛЯ СОЗДАНИЯ КИБЕРФИЗИЧЕСКИХ ПРОИЗВОДСТВЕННЫХ СИСТЕМ В РАМКАХ КОНЦЕПЦИИ INDUSTRY 4.0

Разработка киберфизической производственной системы является сложной научно-технической задачей, поэтому разработчику нужно определить требования, задачи, предъявляемые к разрабатываемой системе и выбрать архитектурную модель ее реализации. В свою очередь выбор архитектурной модели предполагает соблюдение баланса для совокупности требований лиц, заинтересованных в ее разработке. В типичном случае разработка конкретной киберфизической производственной системы нуждается в адаптации к средствам реализации, к реалиям будущего ее использования, сопровождения и эволюции. **Предметом** данного исследования являются архитектурные модели построения сложных киберфизических производственных систем. **Целью** данной статьи является исследование архитектурных моделей DIKW и 5C, по результатам декомпозиции которых, в дальнейшем, станет возможным проведение математического описания элементарных задач каждого уровня и их физического или имитационного моделирования. Для достижения поставленной цели необходимо решение следующих **задач:** провести анализ модели DIKW; провести анализ архитектурной модели 5C; сравнить модель DIKW и архитектурную модель 5C, с помощью ее структурной декомпозиции по уровням, информационных и командных каналов с обратными связями внутри каждой структуры. Проведенные исследования базируются на методах декомпозиции и формализованного представления систем. **Выводы:** по результатам проведения декомпозиции на каждом структурном уровне моделей DIKW и 5C была разработана декомпозиционная структура, на которой показаны основные отличия и общие сходства моделей. Виявлено, что модель 5C, как общая программная оболочка, которая объединяет в себе интегрированные датчики и исполнительные устройства, больше подходит для решения задач разработки киберфизической производственной системы, а интерпретационная модель DIKW больше подходит для решения задач модификации существующих систем на предприятиях, а сам выбор модели разработки киберфизической производственной системы зависит от требований заказчика, существующего оборудования, уровня его автоматизации и уровня финансирования проекта.

**Ключевые слова:** Industry 4.0; Smart Manufacturing; Digital Twins; киберфизические производственные системы; модель DIKW; архитектура 5C.

### Бібліографічні описи / Bibliographic descriptions

Осадчий С. І., Демська Н. П., Олександров Ю. М., Невлюдова В. В. Дослідження архітектурних моделей diKW та 5C для створення кіберфізичних виробничих систем в рамках концепції industry 4.0. *Сучасний стан наукових досліджень та технологій в промисловості*. 2021. № 1 (15). С. 132–140. DOI: <https://doi.org/10.30837/ITSSI.2021.15.132>

Osadchy, S., Demska, N., Oleksandrov, Yu., Nevliudova, V. (2021), "Research of DIKW and 5C architectural models for creation of cyber-physical production systems within the concept of industry 4.0", *Innovative Technologies and Scientific Solutions for Industries*, No. 1 (15), P. 132–140. DOI: <https://doi.org/10.30837/ITSSI.2021.15.132>