

A. PODOROZHNIK, O. BALENKO, V. SOBOL

MODEL AND ALGORITHMS FOR DETERMINING THE LOCATION AND POSITION OF AGRICULTURAL MACHINERY DURING THE MOVEMENT

The **subject** of research is the navigation subsystem of autonomous control system to determine the location and position of agricultural machinery during the movement. The **purpose** of the work is to develop and research model and algorithms to determine the location and position of mobile agricultural machinery using a physical model. The following **tasks** are solved in the article: development of agricultural machinery physical model to collect information from sensors during movement, further development and research of applicability of algorithms for location and position determination. The following **methods** are used: methods of mathematical statistics, methods of information systems theory and data processing, methods of random signals filtration. The following **results** were obtained: during research, the agricultural machinery physical model to collect information from sensors during movement was created. The model includes a GPS receiver, an accelerometer, gyroscope and infrared encoders, to count the rotation of the wheels, as well as its own four wheelbase of agricultural machinery. The modernized GPS coordinate filtration algorithm using a geocheck algorithm is proposed, which according to several successively obtained GPS coordinates calculates the hash received coordinates; if the coordinates have the same hash, it can be argued that the vehicle is in the segment of the area that corresponds to this hash. To determine the physical model position during the movement data from the accelerometer and the gyroscope was processed using Savitzky-Golay and Madgwick filters. With the use of wheels' rotation data, the odometric algorithms for movement and location determining of the agricultural machinery physical model in motion were implemented. **Conclusions:** to improve the accuracy of estimating the location and position agricultural machinery, algorithms complexation of indicators from different navigation systems should be used to reduce the total error. Research results can be applied in the development of new and modifications of existing navigation subsystems of agricultural machinery autonomous control systems.

Keywords: autonomous control system; agricultural machinery; inertial navigation; odometry; satellite navigation.

Introduction

The task of developing and implementing autonomous control systems for aircraft, boats, trucks or cars, forklifts and agricultural transport is quite relevant in today's world. The relevance of such developments is due to human imperfection. Humans, unlike autonomous robots, need breaks for sleep and food, which leads to work stoppages, and fatigue and carelessness can lead to accidents and, as a result, to damage or loss of goods, or even death.

The development and implementation of autonomous control systems is a rather expensive and slow process, but such systems pay off in the long run by reducing net labor, increasing uptime, saving fuel and reducing accidents and product losses. An example of the usefulness of autonomous control systems is the achievements of the American startup Tu Suple. The truck under the control of the autopilot passed the route Nogales (Arizona) - Oklahoma City, with a total length of 1530 kilometers in 14 hours, while a similar route with a driver takes 24 hours [1].

The task of establishing one's own position and location is one of the main tasks facing autonomous control systems, because only knowing your location can correct traffic in case of deviation from the specified route, bypass obstacles and avoid collisions, and so on.

Autonomous control systems for different equipment can be very different from each other. This is due to various factors, among which it is possible to distinguish between the control systems of vehicles depending on the type of work for which the automation of equipment, as well as the characteristics of the environment in which the equipment operates. The environment in which the equipment operates means whether the equipment operates on land, in water or in the air, weather conditions,

as well as characteristic climatic features that may affect the clarity of sensor readings, and features of the environment that affect the choice of sensors, and navigation methods. For example, satellite navigation, which is widely used in mobile technology, works well in open space, but this type of navigation cannot be used to navigate equipment that should work indoors, because the satellite signal is not able to penetrate thick walls. Instead, it is possible to use echolocation indoors, which determines the distance to the walls and obstacles.

Agricultural machinery operates in open spaces where it is difficult to adjust traffic to visual landmarks, such as road signs and markings, or on the basis of echolocation. In some cases, the movement of machinery can be adjusted with the help of visual landmarks – plant sprouts to guide the tractor wheels between the rows. But such types of work as plowing, harrowing or sowing do not have similar guidelines. Also, agricultural machinery works in conditions of dust and dirt, which can affect the sharpness of the image.

Analysis of existing sources and setting the task of research

Existing autonomous control systems for agricultural machinery, to a greater extent, use satellite navigation to determine their location. To improve the location, additional installations are used, the location of which is known with high accuracy, and which are installed next to the field for agricultural machinery and act as an additional signal source. [2, 3].

There are developments on the integration of differential satellite navigation and fuzzy control of agricultural machinery [4, 5]

In the known works the approach to creation of

inertial-satellite navigation system of control of vehicles with use of an artificial neural network for optimization of the used structure of a vector of measurements of navigation subsystems is offered [6, 7].

It is also proposed to use promising developments in the theory of artificial intelligence for the control system of vehicles [8, 9].

Such solutions are either quite expensive, or not accurate enough, or have only theoretical estimates of their operation, so it makes sense to look for other sources to improve the assessment of the location of agricultural machinery.

Aim of the article. This article is devoted to the development and research of methods and algorithms for determining the location and position of an agricultural vehicle model. To achieve this goal, the following objectives are set: to choose methods and algorithms for determining the location and position of agricultural vehicles, select modules and sensors to create a vehicle model, create a physical model of an agricultural vehicle to collect data from modules and sensors while driving, develop and implement methods and algorithms for assessing the location and position of the model during movement, investigate the work of developed methods and algorithms.

Main part

The navigation system is a set of devices, algorithms and software that allow you to orient an object in space. The navigation complex can include both complex navigation systems (for example, a satellite navigation system) and individual instruments that allow you to determine the geographical coordinates of an object or its location by other objects.

Navigation systems carry out navigation using various instruments. Devices such as accelerometers, gyroscopes, magnetometers, echolocators, radars, lidars and other devices have acquired great use.

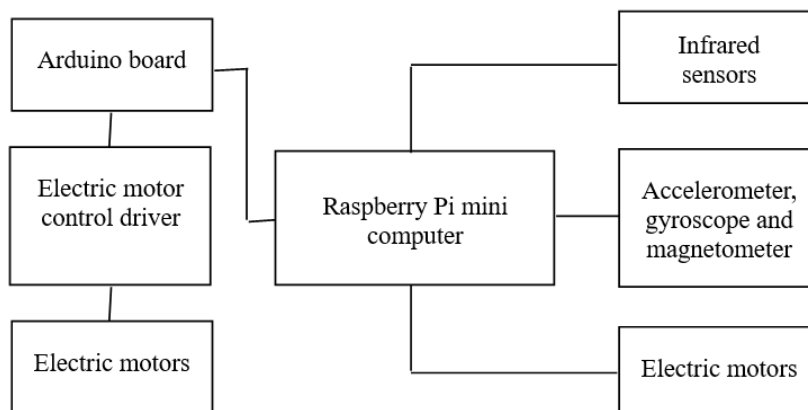

Fig. 1. Block diagram of the model

The view of the assembled physical model is shown in fig. 2.

Data collected during movement was processed on the HP Pavilion 15-n078sr computer, which has an Intel Core i5-4200U processor at 2.3 GHz.

Today, various systems of autonomous control use such types of navigation as inertial, satellite and odometric.

Inertial navigation is a navigation method that is based on the properties of inertial bodies and is autonomous, that is, it does not require external landmarks or signals. The disadvantage of this type of navigation is that the error obtained from accelerometers and gyroscopes accumulates over time, so the position should be periodically adjusted from another type of navigation system [9, 10].

Satellite navigation is based on the calculation of the distance from the object being tracked to satellite antennas. The accuracy of satellite navigation can be affected by weather conditions, signal reflection from houses or trees, and the quality of receivers. The advantage of satellite navigation is that error does not accumulate over time [10, 11].

Odometry is a method for estimating the movement of wheeled vehicles, which is based on determining the path traveled along its left and right wheels. This method is error sensitive due to the integration of velocity measurements over time to obtain location estimates. In most cases, efficient use of the odometer requires fast and accurate data collection, as well as calibration of instruments [12, 13].

Based on the study, it was decided to conduct research on methods and algorithms for estimating the location and position of transport using satellite, inertial and odometric navigation [14].

To test the efficiency of the algorithms, it was decided to build a simplified model of a vehicle for collecting data from sensors while driving [15]. The created physical model of the agricultural vehicle includes: the NEO-6M module, for reception and processing of the GPS signal; MPU-9250 module, which includes a 3-axis accelerometer, gyroscope and magnetometer; infrared encoders, to obtain information about the rotation of the wheels of the model. The block diagram of the model is shown in fig. 1.

GPS coordinates received from the module are not reliable. The real coordinates of the object being tracked are within a radius of the resulting coordinates. To quickly filter the obtained coordinates, a filter algorithm was developed that is based on the geochex hashing algorithm.

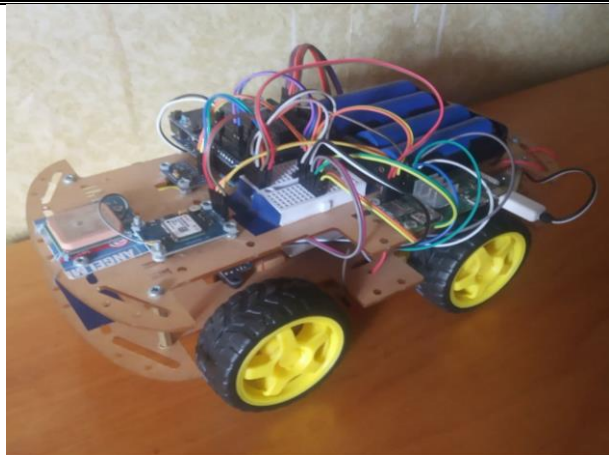

Fig. 2. View of the created physical model

Geochex is a hashing algorithm that converts the value of longitude and latitude to a hash type of a given length [16]. In conversion, each hash corresponds to the center coordinates of a hexagonal area. Thus, the coordinates included in the same area will have the same hash. As the length of the hash increases, the area of hexagonal segments decreases.

The filter algorithm works as follows: several GPS coordinates are obtained; calculating the hash of the obtained coordinates; if the coordinates have a common hash, then we can say that we are in the segment of the area of which corresponds to this hash. Successful filtering of GPS coordinates is possible when the radius of the inner circle of the hexagonal segment is greater than the radius of the GPS error, since in this case the entire drift of the coordinates will be suppressed.

This algorithm requires fewer operations than if we calculated the center of the intersection of the radius of error of the obtained coordinates.

Clarifying GPS coordinates is useful because knowing what area we are in at the moment can adjust location calculations from different sources.

To test the operation of the algorithm, a test drive was conducted in the park. The approximate route can be seen in fig. 3.

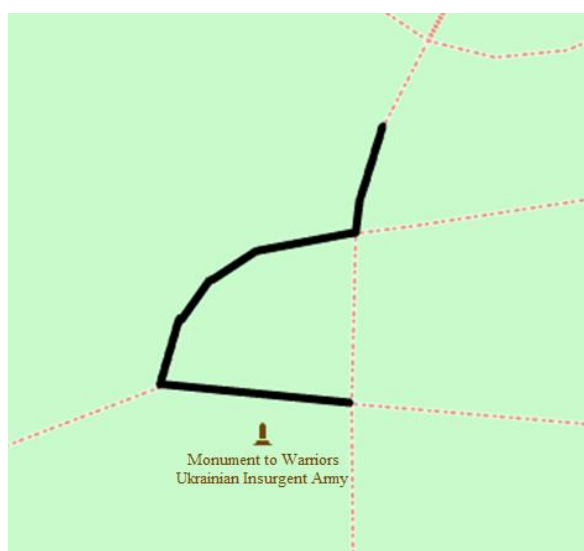

Fig. 3. Approximate route of movement on park

In 166.5 seconds of bout, 170 coordinates were collected, which is about once a second. A hash length of 13 was chosen for filtering. At this length, the radius of the inner circle of the hexagon will be approximately 0.53 meters. The radius of error of the obtained GPS coordinates in the period when the model was not moving was approximately 0.3 meters from the center point. After filtering, there were 68 points left, which belonged to 29 unique hashes. The difference between the coordinates before and after filtering is shown in fig. 4.

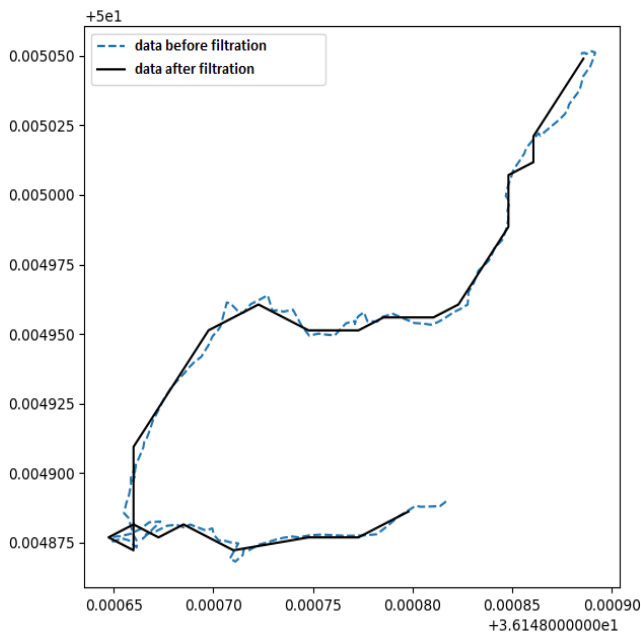

Fig. 4. The difference between the coordinates before and after filtering

Accelerometer and gyroscope data can be used to determine the position of the model. It was decided to use the Madgwick filter for this task.

The Madgwick filter is a filter developed by Sebastian Madgwick to determine the position in space from the readings of gyroscope, accelerometer and, in some implementations, magnetometer sensors. This filter calculates the position in the form of a quaternion [17]. The general idea of the Madgwick filter is to determine the position of the object by combining estimates of the position of gyroscopic measurements and the direction obtained by measuring the accelerometer. The obtained quaternion was reduced to the values of roll, pitch and yaw in the form from π to $-\pi$ radians.

When analyzing the data obtained from the accelerometer and gyroscope, it was found that during the movement of the model, the data become very constricted, which leads to a large error in the calculation of the quaternion. It was decided to use the Savitsky-Goley filter to filter the data.

The Savitsky-Goley filter is a digital filter that can be applied to a set of digital data points in order to smooth the data, i.e. to increase the accuracy of the data without distorting the signal trend [18]. This is achieved in a process known as convolution, by fitting successive subsets of adjacent data points with a low-degree polynomial by the method of linear least squares. When the data points are equidistant, you can find 26 least

squares analytical solutions in the form of a single set of "convolution coefficients" that can be applied to all subsets of data to estimate the smoothed signal (or smoothed signal derivatives) at the center point of each subset.

The Savitsky-Goley filter has two variable parameters: the length of the window and the order of the polynomial. To filter the obtained data, it was decided that the length of the window will be 21, and the order of the polynomial - 3. These numbers are due to the fact that at such values the estimate of model rotations was similar to that which was actually with clearly visible stopping moments. An example of data before and after filtering is shown in fig. 5.

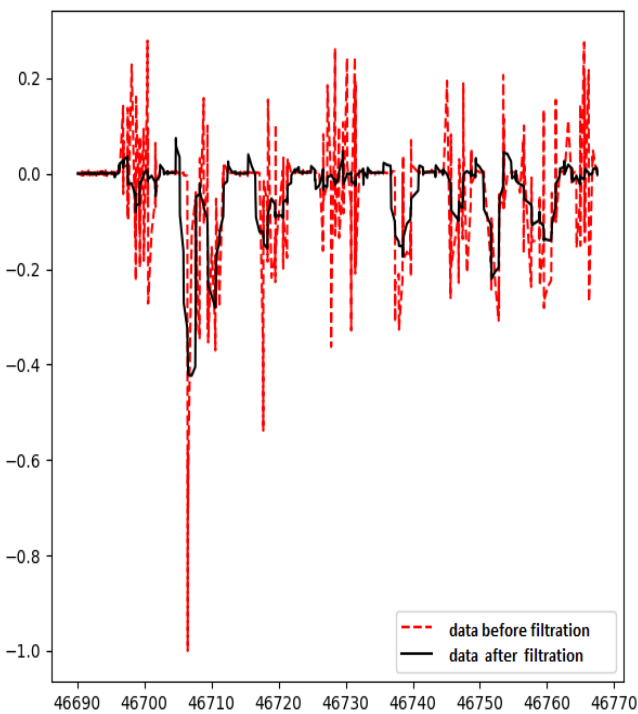

Fig. 5. Example of data from gyroscope g_z before and after filtering

To assess the situation using Savitsky-Goley and Madgwick filters, a test run was performed indoors. Initially, the model moved forward and to the right. When the model turned about 90 degrees from the initial state, it stopped and began to move back and forth. Turning approximately 135 degrees from the initial state, the model stopped again and began to move forward and to the right. When the model turned almost 180 degrees from the initial state, it stopped and, passing back and to the left, returned to 180 degrees. The view of the calculated change of position during movement is shown in fig. 6.

To improve position calculations, you can use additional accelerometers and gyroscopes, which will reduce sensor error.

Information about the position of the model while driving is very useful for improving location calculations from navigation systems. For example, when moving uphill, the movement in the X and Y coordinates will be less than in a straight line. Knowing the position of the vehicle when entering the mountain, you can adjust the calculation.

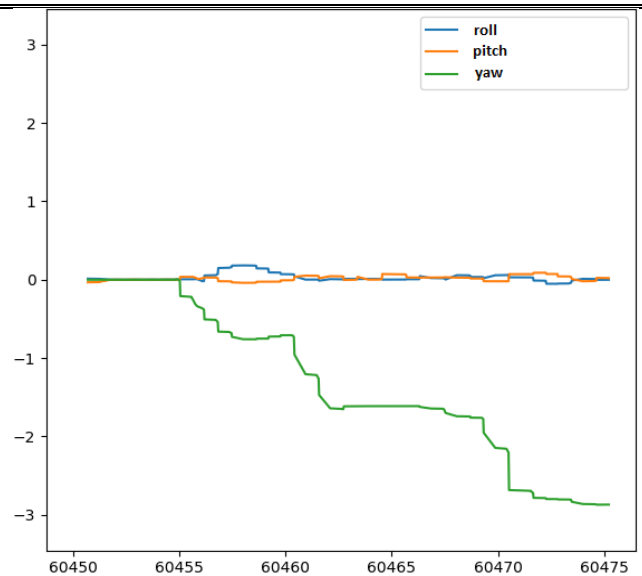

Fig. 6. The estimate of the position during the movement of the model

Odometric estimate of the model displacement is calculated on the basis of information about the distance traversed by the wheels. Infrared encoders monitor the speed of the wheels thanks to the disks with twenty holes attached to the wheels. When the hole passes the encoder, a signal is generated indicating that the wheel has made one twentieth ($1/20$) revolution.

The distance traversed by the wheel is calculated by the formula:

$$L = \frac{n_1 + n_2}{2N} \pi D, \quad (1)$$

where L – total path travelled by the side of the model; n_1 and n_2 – number of rear and front wheel encoder readings; N – number of slots in disk; D – wheel diameter.

The length of the traversed path in the center of the model (L_c) will be half the sum of the traversed path on the left and right sides.

Rate deviation is calculated by formula:

$$Q_{(t+1)} = Q_t + \frac{L_r + L_l}{2 \cdot W}, \quad (2)$$

where $Q(t)$ – the robot position at a time t ; L_r – distance travelled by the right side of the model; L_l – distance travelled by the left side of the model; W – the distance between the centers of the wheels of the left and right sides.

For the image of coordinates on the map it is possible to calculate Cartesian coordinates:

$$X_{(t+1)} = X_{(t)} + L_c \cdot \cos(Q_{(t+1)}), \quad (3)$$

$$Y_{(t+1)} = Y_{(t)} + L_c \cdot \sin(Q_{(t+1)}), \quad (4)$$

Data for testing the algorithm were obtained during data collection from the accelerometer and magnetometer.

References

1. Kolodny, L. (2021), "TuSimple says its self-driving trucks shaved 10 hours off a 24-hour run", available at : <https://www.cnn.com/2021/05/19/tusimple-self-driving-trucks-saved-10-hours-on-24-hour-run.html> (last accessed 01.06.2021).
2. "An Introduction to GNSS", available at : <https://novatel.com/an-introduction-to-gnss/> (last accessed 01.06.2021).
3. Mihajlow, R., Demirev, V. (2018), "Application of GPS navigation in agricultural aggregates", *Annual Journal of Technical University of Varna*, Vol. 2, No. 2, P. 14–19. DOI: <https://doi.org/10.29114/ajtuv.vol2.iss2.84>
4. Li, Y., Cao, Q., Liu, F. (2020), "Design of control system for driverless tractor", *Proceedings of the MATEC Web of Conferences CSCNS2019*, Vol. 309, 04001, 12 p. DOI: <https://doi.org/10.1051/mateconf/202030904001>
5. Kholodyuk, O. (2020), "Global navigation satellite systems and their role in precision agriculture technologies", *Engineering, Energy, Transport AIC*, No. 2 (109), P. 71–87. DOI: <https://doi.org/10.37128/2520-6168-2020-2-8>
6. Makarenko, V. G., Bogomolov, A. V., Rudakov, S. V., Podorozhnyak, A. A. (2007), "Technology for constructing an inertial-satellite navigation system for controlling vehicles with neuronet optimization of the composition of the measurement vector" ["Tekhnologiya postroeniya inertial'no-sputnikovoy navigatsionnoy sistemy upravleniya transportnymi sredstvami s neyrosetevoj optimizatsiei sostava vektora izmereniy"], *Mekhatronika, avtomatizatsiya, upravlenie*, No. 1, P. 39–44, available at : <http://novtex.ru/mech/mech07/archiv01.htm> (last accessed 01.06.2021).
7. Colantoni, A., Monarca, D., Laurendi, V., Villarini, M., Gambella, F., Cecchini, M. (2018), "Smart Machines, Remote Sensing, Precision Farming, Processes, Mechatronic, Materials and Policies for Safety and Health Aspects", *Agriculture*, Vol. 8, No. 4 (47), 11 p. DOI: <https://doi.org/10.3390/agriculture8040047>
8. Parzhin, Y., Kosenko, V., Podorozhniak, A., Malyeyeva, O., Timofeyev, V. (2020), "Detector neural network vs connectionist ANNs", *Neurocomputing*, Vol. 414, P. 191–203. DOI: <https://doi.org/10.1016/j.neucom.2020.07.025>
9. "Inertial navigation system: how it works" ["Inercial'naja navigacionnaya sistema: kak jeto rabotaet"], available at : <https://rostec.ru/news/kak-eto-rabotaet-inercial'naya-navigacionnaya-sistema/> (last accessed 01.06.2021).
10. Wang, H., Noguchi, N. (2021), "Real-time states estimation of a farm tractor using dynamic mode decomposition", *GPS Solutions*, No. 25:16, 12 p. DOI: <https://doi.org/10.1007/s10291-020-01051-5>
11. "Principles of satellite navigation" ["Principy sputnikovoj navigacii"], available at : <https://www.glonass-iac.ru/guide/navfaq.php> (last accessed 01.06.2021).
12. "Odometry" ["Odometrija"], available at : <http://robocraft.ru/blog/technology/736.html> (last accessed 01.06.2021).
13. Poddar, S., Kottath, R., Karar, V. (2018), "Evolution of Visual Odometry Techniques", available at : <https://arxiv.org/abs/1804.11142> (last accessed 01.06.2021).
14. Sobol, V., Podorozhniak, A. (2021), "Inertial navigation systems of agricultural machinery" [Systemy inertialnoi navihatsii silskohospodarskoi tekhniki], available at : <http://repository.kpi.kharkov.ua/handle/KhPI-Press/52866> (last accessed 01.06.2021).
15. Sobol, V., Podorozhniak, A. (2020), "Automation of agricultural machinery" ["Avtomatyzatsiia roboty silskohospodarskoi tekhniki"], available at : <http://repository.kpi.kharkov.ua/handle/KhPI-Press/52853> (last accessed 01.06.2021).
16. "GeoHex", available at : <https://sites.google.com/site/geohexdocs/> (last accessed 01.06.2021).
17. "Madgwick Filter", available at : <https://nitinjsanket.github.io/tutorials/attitudeest/madgwick> (last accessed 01.06.2021).
18. "Savitzky-Golay Filter", available at : http://www.statistics4u.info/fundstat_eng/cc_filter_savgolay.html (last accessed 01.06.2021).

Received 27.05.2021

Відомості про авторів / Сведения об авторах / About the Authors

Подорожняк Андрій Олексійович – кандидат технічних наук, доцент, Національний технічний університет "Харківський політехнічний інститут", доцент кафедри обчислювальної техніки та програмування, Харків, Україна; email: andrii.podorozhniak@kpi.edu.ua; ORCID: <https://orcid.org/0000-0002-6688-8407>.

Подорожняк Андрей Алексеевич – кандидат технических наук, доцент, Национальный технический университет "Харьковский политехнический институт", доцент кафедры вычислительной техники и программирования, Харьков, Украина.

Podorozhniak Andrii – PhD (Engineering Sciences), Associate Professor, National Technical University "Kharkiv Polytechnic Institute", Associate Professor of the Department of Computer Engineering and Programming, Kharkiv, Ukraine.

Баленко Олексій Іванович – кандидат технічних наук, Національний технічний університет "Харківський політехнічний інститут", доцент кафедри обчислювальної техніки, Харків, Україна; email: olexsii.balenko@kpi.edu.ua; ORCID: <https://orcid.org/0000-0002-2314-0984>.

Баленко Алексей Иванович – кандидат технических наук, Национальный технический университет "Харьковский политехнический институт", доцент кафедры вычислительной техники и программирования, Харьков, Украина.

Balenko Olexsii – PhD (Engineering Sciences), National Technical University "Kharkiv Polytechnic Institute", Associate Professor of the Department of Computer Engineering and Programming, Kharkiv, Ukraine.

Соболь Валентин Вікторович – магістр, Національний технічний університет "Харківський політехнічний інститут", студент кафедри обчислювальної техніки та програмування, Харків, Україна; email: valentyn.sobol@cit.kpi.edu.ua; ORCID: <https://orcid.org/0000-0002-6541-4971>.

Соболь Валентин Викторович – магистр, Национальный технический университет "Харьковский политехнический институт", студент кафедры вычислительной техники и программирования, Харьков, Украина.

Sobol Valentyn – Master of Computer Engineering, National Technical University "Kharkiv Polytechnic Institute", Student of the Department of Computer Engineering and Programming, Kharkiv, Ukraine.

МОДЕЛЬ ТА АЛГОРИТМИ ВИЗНАЧЕННЯ МІСЦЕЗНАХОДЖЕННЯ ТА ПОЛОЖЕННЯ СІЛЬСЬКОГОСПОДАРСЬКОЇ ТЕХНІКИ ПІД ЧАС РУХУ

Предметом дослідження є навігаційна підсистема системи автономного управління для визначення місцезнаходження та положення сільськогосподарської техніки під час руху. **Мета** роботи – розробка та дослідження моделі і алгоритмів для визначення місцезнаходження та положення мобільної сільськогосподарської техніки з використанням фізичної моделі. В статті вирішуються наступні **завдання**: розробка фізичної моделі сільськогосподарської техніки для збору інформації від датчиків під час руху, подальша розробка та дослідження застосовності алгоритмів визначення місцезнаходження та положення. Використовуються такі **методи**: методи математичної статистики, методи теорії інформаційних систем та обробки даних, методи фільтрації випадкових сигналів. Отримано наступні **результати**: під час проведених досліджень було створено фізичну модель сільськогосподарського транспортного засобу для збору інформації з датчиків під час руху. До складу моделі входять GPS-приймач, акселерометр, гіроскоп та інфрачервоні енкодери, для підрахунку обертів коліс, а також сама чотирьохколісна база транспортної техніки сільськогосподарського призначення. Було запропоновано модернізований алгоритм фільтрації GPS-координат з використанням алгоритму хешування геохекс, який за декількома послідовно отриманими GPS-координатами виконує розрахунок хешу отриманих координат; якщо координати мають спільний хеш, то можна стверджувати, що транспортний засіб знаходиться в сегменті площі, якій відповідає даний хеш. Для визначення положення фізичної моделі під час руху дані від акселерометру та гіроскопу було оброблено за допомогою фільтрів Савицького-Голя та Маджвіка. Із застосуванням даних про обертання коліс було реалізовано одометричні алгоритми визначення переміщення та місцезнаходження фізичної моделі сільськогосподарського транспортного засобу під час руху. **Висновки**: для підвищення точності оцінки місцезнаходження і положення сільськогосподарських транспортних засобів слід використовувати алгоритми комплексування показників від різних навігаційних систем для зменшення сумарної похибки. Результати дослідження можуть бути застосовані при розробці нових, та модифікації існуючих навігаційних підсистем автономних систем управління сільськогосподарської техніки.

Ключові слова: система автономного управління; сільськогосподарська техніка; інерційна навігація; одометрія; супутникова навігація.

МОДЕЛЬ И АЛГОРИТМЫ ОПРЕДЕЛЕНИЯ МЕСТОПОЛОЖЕНИЯ И ПОЛОЖЕНИЯ СЕЛЬСКОХОЗЯЙСТВЕННОЙ ТЕХНИКИ ВО ВРЕМЯ ДВИЖЕНИЯ

Предметом исследования является навигационная подсистема системы автоматизированного управления для определения местонахождения и положения сельскохозяйственной техники во время движения. **Цель** работы – разработка и исследование модели и алгоритмов для определения местонахождения и положения мобильной сельскохозяйственной техники с использованием физической модели. В статье решаются следующие **задачи**: разработка физической модели сельскохозяйственной техники для сбора информации от датчиков во время движения, дальнейшая разработка и исследование применимости алгоритмов определения местоположения и положения. Используются следующие **методы**: методы математической статистики, методы теории информационных систем и обработки данных, методы фильтрации случайных сигналов. Получены следующие **результаты**: в ходе проведенных исследований была создана физическая модель сельскохозяйственного транспортного средства для сбора информации с датчиков во время движения. В состав модели входят GPS-приемник, акселерометр, гироскоп и инфракрасные энкодеры, для подсчета оборотов колес, а также сама четырехколесная база транспортной техники сельскохозяйственного назначения. Был предложен модернизированный алгоритм фильтрации GPS-координат с использованием алгоритма хеширования геохекс, который по нескольким последовательно полученным GPS-координатами выполняет расчет хеша полученных координат; если координаты имеют общий хэш, то можно утверждать, что транспортное средство находится в сегменте площади, которой соответствует данный хэш. Для определения положения физической модели во время движения данные от акселерометра и гироскопа было обработано с помощью фильтров Савицкого-Голя и Маджвика. С применением данных об обращении колес был реализован одометрический алгоритм определения перемещения и местонахождения физической модели сельскохозяйственного транспортного средства во время движения. **Выводы**: для повышения точности оценки местонахождение и положение сельскохозяйственных транспортных средств следует использовать алгоритмы комплексирования данных от различных навигационных систем для уменьшения суммарной погрешности. Результаты исследования могут быть применены при разработке новых и модификации существующих навигационных подсистем автономных систем управления сельскохозяйственной техники.

Ключевые слова: система автономного управления; сельскохозяйственная техника; инерционная навигация; одометрия; спутниковая навигация.

Бібліографічні описи / Bibliographic descriptions

Подорожняк А. О., Баленко О. І., Соболев В. В. Модель та алгоритми визначення місцезнаходження та положення сільськогосподарської техніки під час руху. *Сучасний стан наукових досліджень та технологій в промисловості*. 2021. № 2 (16). С. 32–38. DOI: <https://doi.org/10.30837/ITSSI.2021.16.032>

Podorozhniak, A., Balenko, O., Sobol, V. (2021), "Model and algorithms for determining the location and position of agricultural machinery during the movement", *Innovative Technologies and Scientific Solutions for Industries*, No. 2 (16), P. 32–38. DOI: <https://doi.org/10.30837/ITSSI.2021.16.032>