

A. SKORKIN, O. KONDRATYUK

THE BASIC PRINCIPLES OF THE INTEGRATED MANAGEMENT OF THE PROCESS OF ASSEMBLY AND THREADING

The **subject** matter of this article is the issues related to the integrated management of assembling operations of fastening and threading elements at all stages of their implementation. The **goal** is to develop the generalized structure of the data management system of the process of assembly and threading. The **objectives** are: to justify the principles of managing the assembly and threading process at each stage of the assembly to improve the efficiency of these operations, to study the power, accuracy and performance characteristics of the connections and to draw the conclusion that suggested the theory of assembly management is efficient. The following **results** are obtained. The article presents the analytical dependencies of the force indexes of threading in the course of the package and sheet assembly, including the tightening force while joining; the assembly of a multilayered package of dissimilar sheet materials was analyzed. On the basis of the theoretical analysis, the dependences of the power indices of threading during the package and sheet assembly were determined. The assembly of the package of sheet materials was investigated, including a multilayered package of dissimilar materials of a "metal-plastic" type. **Conclusions.** The process of assembling threaded joints with the use of management principles was used; these principles enable increasing the efficiency of the assembly process, reducing the complexity of the basic operations, and improving the quality of the joints obtained. The use adaptive control of the screwing speed on the main threading transitions is suggested for reducing the torque. The technology of making threaded joints with given properties is developed, the main ways of increasing the efficiency of assembly and threading processes are determined on the basis of the integrated control system for the assembly process.

Keywords: assembly, fastening elements, threading process, torque.

Introduction

In the process of assembling threaded joints, modern high-performance equipment, automation and intensification means, systems of monitoring the parameters of assembly operations and the resulting connections are widely used.

However, despite the advance in the development of thread-assembling technologies, the labour intensity of the basic operations of assembling threaded parts still remains within 35–40%. The efficiency of technologies is determined by the total technical effect obtained from their implementation. With regard to the assembly of threaded connections, the efficiency is determined by the indices:

- productivity and cost-efficient performance of coupling operations;
- labour intensity;
- the quality of the joints obtained;

One direction for improving these indices is introducing the assembly and threading processes based on the use of thread fasteners in the product designs.

The analysis of literary sources and problem setting

A thorough study of fasteners with thread and profile sections is based on the positive indicators of their installation and the qualitative characteristics of the joints obtained. The variety of fastening and threading parts is constantly being improved and enhanced. Combining the processes of threading, coupling and tightening the joints in one transition, such details make it possible to provide high strength, stopping and maintainability rates in threaded pairs [1, 4.].

Threading studs, screws and bolts, bushings, pins and other elements are manufactured in according to the state and industry standards, technical conditions, and also in accordance with the catalogues of leading firms and corporations [2, 8]. The control over the issues of their

production, assembly technologies, resource tests of joints, their quality characteristics and the development of promising designs of parts is carried out by leading research and production organizations.

The utilization of fasteners according to the branches of industry is as follows:

- vehicle manufacturing industry – 42%,
- aerospace industry – 14.3%,
- others – 43.7%.

The assortment of fasteners is as follows:

- male thread– 40%,
- fasteners for aerospace industry – 21%,
- plain – 13%,
- female thread– 11%,
- other shaped – 9%,
- non-standard – 6%.

The assortment of threading fasteners is being constantly enlarged.

The most widely used fasteners are self-tapping and self-rolling screws, studs, threaded bushings. These fastening elements are widely used in machine building, vehicle manufacturing industry, aircraft building, electrical engineering, instrument making, building and other industries.

The analysis of situations shows that not only the process should be managed, but the entire complex including the stages of production preparation, preparatory stages: feeding, orientating and engaging.

The development of the technology of the assembly process includes the preparatory, synthetic, analytical and final stages [10]. With regard to the assembly and threading processes, this procedure can be represented as the following structure:

- the preparatory technological stage (data support, analysis and decision making, analytics, final stages);
- the preparatory design stage (design drafting for tooling auxiliary equipment, production of tooling, installation, settings and adjustments, test operations, troubleshooting);

- the stage of assembly (parts loading and installing, coupling transitions, removing parts and units);
- post-assembly stage (connection supervision, testing pilot batch, the analysis of rejected parts, the adjustment of tooling and control systems, the efficiency analysis and technical and economic assessment).

The goal and objectives of the study

The goal of this study is to develop the generalized structure of the assembly and threading process by the data management system. Proceeding from the goal of the study, the following tasks should be solved:

1. the principles of managing the assembly and threading process at each stage of the assembly should be justified to improve the efficiency of these operations.
2. the power, accuracy and performance characteristics of joints should be studied and the conclusion about the efficiency of the suggested theory of assembly management should be made.

The main material of the study

The process of forming joints with thread parts involves a finite set of parameters whose properties must be taken into account when carrying out experimental studies.

The main indices of the process of assembly and the joints obtained are formed at the following stages:

1. Informational and analytical.
2. Designed (synthetic).
3. Preparatory.
4. Assembly.

The correct choice of the joint type, fastening element, tightening method, assembly modes, and other parameters detected at the first stage enable establishing the specific pack of designed parameters included in the initial data map of the "Tools-Screw" system that is used in the second stage of the technological preparation of production.

At the preparatory stage, the design elements of the technological system of the screwing machine are developed, which is:

- technological tools (cartridges, devices, loading and feeding devices);
- the conditions for the implementation of the main stages of the assembly (orientation conditions, engaging efforts, the radial rigidity of the tools, the assembly speed control law and so on);

and the choice of assembly equipment is justified.

At the last stage, the following indices should be ensured [9]:

- the reliability of parts coupling;
- the energy efficiency of the process;
- the high productivity of tools;
- qualitative parameters of the obtained joints.

Taking into account the heterogeneity and different physical nature of these indices, a complex quality indicator is suggested that is developed as the function:

$$S = f(M_t; N; V; \eta) \rightarrow \min \quad (1)$$

where N is the energy intensity of the process of assembly, Wt/s ; V is the speed of screwing, m/s , m/c ; η is the coefficient of the thread completeness [105].

The optimal area of function (1) can be ensured by developing certain levels of control parameters that are presented in table 1.

Table 1. The stages of control parameters development

No.	Control parameters	Designation	Assembly stages			
			1	2	3	4
1	Allowance	δ		+	+	
2	Screwing speed	V		+	+	+
3	Coupling length	$z \cdot P$		+		
4	Bevel lead angle	φ	+	+		
5	Thread pitch and diameter	P, d	+	+		
6	Core hardness	HB_c		+	+	
7	Greasing	-	+	+	+	
8	Tightening moment	M_t		+	+	+
9	Orientation inaccuracies	$[e], [\gamma]$		+	+	
10	Workpiece location pattern	-		+	+	
11	Chuck hardness	j_n		+	+	
12	Fastener type	-	+	+		
13	Torque	M_t		+		+
14	Case hardness	HB_K		+	+	
15	Profile filling coefficient	η		+	+	

Table 1 shows that three parameters V , M_t , M operate at the stage of coupling. Along with the other parameters that are set at the design stage of assembly, these parameters are the main ones that affect the function level at the fourth stage.

In this case, the different possibilities of impact on these parameters should be taken into consideration. For example, if the speed and torque can be controlled by the drive system of the screwing machine, the screwing torque is the magnitude of the derivative that is determined by

the speed and other factors developed in the 2-nd and 3-rd stages [1, 4, 9].

If the controlled process is presented systematically, all the parameters of Table 1 can be divided into 3 groups:

- setting (initial);
- disturbing (that have a random character);
- outputs that determine the level of the target function S .

The diagram of such system is shown in fig. 1.

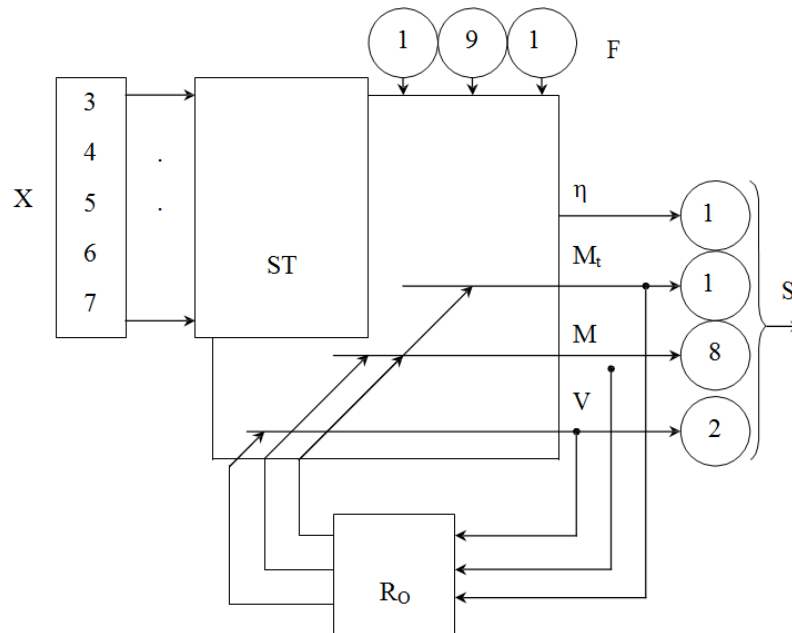

Fig. 1. The structure of the assembly control

In the second and third stages, the parameters X and F which are specified in technical conditions or substantiated analytically are developed. The latter ones have only a calculated nature at these stages, and in the process of assembly (the 4-th stage), they appear as random quantities. The set of calculated values of these factors forms a pseudo-block of the master device (MD). The output values Y (2, 8, 13) form the level of the target function S and are controlled by the feedback system of the screwing machine. When passing the regulator RO , they can form both their own level and other output values. Factors X and F also affect the output values (they are not shown in the communication circuit).

Since the torque is a complex index that determines the assembly level and the quality of the formed joints to a large extent [8, 4, 9], the validity of theoretical guidelines of the 3-rd section should be confirmed and the possibilities of the target function minimization should be determined in the process of parts joining.

This task was solved experimentally. Theoretical values of torque for various materials and fastening elements were previously calculated. The calculation was made for the following materials:

- sheet steel up to 1.5 mm thick;
- aluminium alloy Al4;
- textolite;
- organic glass;

- polystyrene for general use.

These data were used to compare theoretical and experimental studies.

A number of determining factors is given with account of table 1 on the basis of the analysis of their impact on the torque:

The allowance δ is determined according to the recommendations of the works [1, 9] at the level

$$\delta = 0,5 - 0,58 P \quad (2)$$

The parameters of threading and the lead-in geometry are given by the requirements of a technical drawing or are determined by the type of the fastener used. This does not relate to the parameters 6, 12, 14.

The greasing type (7) and the parameter of the technical machine system (9, 10, 11) relate to technical recommendations or are determined by calculation (jn) or are of random nature and cannot be determined as determining factors.

On the basis of stated above, four factors d , P , l/d or z , V are selected for the torque experimental model. Their impact is much greater in the models of the previous researching where they were used and [1, 9, 10,]. table 2 shows the levels of determining factors and their variability intervals.

Table 2. Determining factors

The levels of factors		Factors			
		<i>d</i>	<i>P</i>	<i>ld</i>	<i>V</i>
		MM	MM	–	m/c
Upper	+	6	1,5	1,5	0,073
Major	0	4,5	1,0	1,0	0,047
Lower	–	3	0,5	0,5	0,021
Vari ability interval	Δx	1,5	0,5	0,5	0,026

The character of the impact of determining factors of the torque is determined in the course of previous experiments.

The thread pitch, the length of thread engagement, and the speed have the greatest effect. Therefore, the use of the dependence of the second order is used as a model:

$$M_t = a_0 + \sum_{1 \leq i \leq k} a_i \times x_i + \sum_{1 \leq i \leq j \leq k} a_{ij} \times x_i \times x_j + \sum_{1 \leq i \leq k} a_{ii} \times x_i^2, \quad (3)$$

where a_0 is a free term; a_i , a_{ij} , a_{ii} are true values of the model coefficients; k is a number of factors.

The order of conducting experiments and the processing of the results correspond to the methods of planning the experiments of the second order. However, the question of selecting the most optimal form of the plan was previously decided. One criterion of optimality can be considered a number of experiments in them. The symmetrical composite orthogonal plans were rejected because of the complexity of organizing experiments according to the levels of determining factors assigned to star points, and the most economical and close to D-optimal Hartley plans were adopted for the implementation. One requirement for a kernel plan is realized in them: it should be a replica which enables assessing the coefficients for pair interactions independently of one another. Replicas with one-, two-

and four-letter interactions meet such requirement. So, in the tasks where $k = 4$ the replicas $24-1$ c $1 = \pm x_1 x_2 x_4$, $1 = \pm x_1 x_3 x_4$, $1 = \pm x_2 x_3 x_4$, $1 = \pm x_1 x_2 x_3$ are realized.

The Hartley plan on the cube with $k = 4$ and a number of experiments in the kernel $N_1 = 8$, with a number of star points $2k = 8$ and one experiment in the centre $\eta_0 = 1$, was selected as the basis. The total number of experiments $N = 17$.

The device for processing data in the Excel environment was used for automating the regression analysis to process the results of the plan. This tool enables obtaining regression coefficients of a full-sized model along with simultaneous obtaining a set of estimation statistics (the variance of regression coefficients $S^2 = [a_i]$, the general correlation deviation $\hat{\eta}_B$, the coefficient of multiple correlations R_{ij} , and so on).

The further sequence of processing the experimental data was carried out according to the standard method described in a number of papers [3, 5, 6]:

1. The significance of the coefficients of the model according to the t-criterion was checked.

2. The adequacy of the final version of the model according to the F-criterion was checked.

The obtained coefficients of the regression equations are given in table 3.

Table 3. The coefficients of the regression equations for determining the torque values (package assembly)

Material	a_0	a_1	a_2	a_3	a_4	a_5	a_6	a_7	a_8
Al 4	-689935	79183,2	490057	-678978	119414	8,64	17,05	135791	56,1
electrotechnical laminated cloth	-1E+06	167304,4	982374	-2E+06	269239	6,75	16,11	356189	103,7
organic glass	-1E+06	144728,4	838935	-2E+06	235852	3,71	10,24	321675	85,9
polystyrene	-512827	60647,7	349318	-687172	99320	1,16	3,63	137434	35,1
Material	a_9	a_{10}	a_{11}	a_{12}	a_{13}	a_{14}	a_{15}	a_{16}	
Al 4	-1250,7	476,5	-2E+06	4186780	-63087	-12,79	7899487	-1E+08	
textolite	-1278,4	485,1	-4E+06	9374551	-132438	-21,25	2,1E+07	-2E+08	
organic glass	-824,48	321,7	-4E+06	8214449	-114285	-17,69	1,9E+07	-2E+08	
polystyrene	-285,91	116,6	-2E+06	3462976	-47809	-7,40	8230443	-9E+07	

The generalized form of the experimental model is as follows:

$$M_t = a_0 + a_1 \times d_1 + a_2 \times P + a_3 \times l/d + a_4 \times P^2 + a_5 \times l/d^2 + a_6 \times P \times l/d + a_7 \times d \times l/d + a_8 \times V \times l/d + a_9 \times P \times l/d \times V^2 + a_{10} \times P \times V^2 + a_{11} \times d \times V + a_{12} \times d \times V^2 + a_{13} \times d \times P^2 + a_{14} \times P \times d \times V \times l/d + a_{15} \times V + a_{16} \times V^2 \quad (4)$$

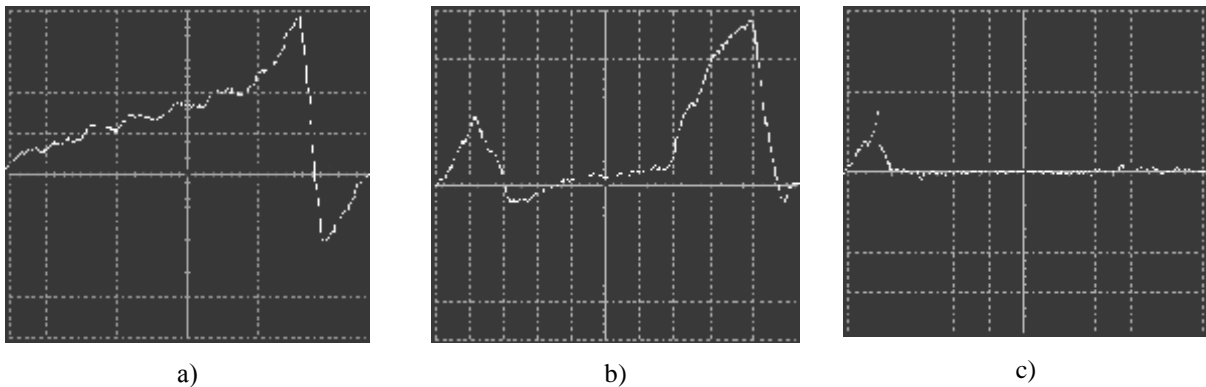

Fig. 2 shows the oscilloscope patterns of the torque for the case made of the Al4 alloy (a) and the sheet assembly (b) 1 mm thick made of the same material. The latter oscilloscope pattern (c) shows the change of the torque for contact pins with the large angle of thread (the material of the sheet is textolite). DSO 2100 oscilloscope was used.

Fig. 3 shows the oscilloscope pattern of the torque while screwing the standard M3 screw in a clearance hole for a case made of the Al4 alloy. The K12-22 oscilloscope was used.

Fig. 2. Torque oscilloscope patterns

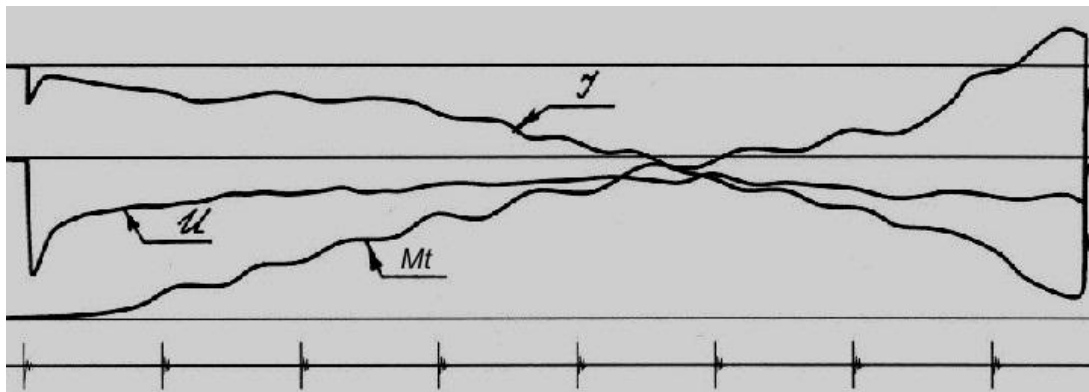

Fig. 3. The oscilloscope pattern of the torque, current, and voltage of the driving electric motor

If the screwing process is considered up to tightening transition, the level of the target function at this stage will be developed only by the values of the torque and speed, and the speed is a determining factor of the moment function. So, the following sequence of determining the target function is evident:

$$X, F \rightarrow V \rightarrow M_t \rightarrow S, \quad (5)$$

And, as the parameters X, F are determined up to the 4-th order, the optimal value of the speed will develop the level of productivity, energy intensity, and the quality of joints that correspond to the function optimum S .

The calculation of torque according to the regression equations showed the following nature of their change: the torque values decreased to a certain limit with increasing speed and then increased again. The latter phenomenon can be explained by the dynamic processes that arise in the threaded contact at high speeds of screwing. To a greater extent, this is noticeable for screws with a large thread pitch.

It should be noted that threading is a complex process, that is affected not only by the speed of screwing, but also by the structural parameters of the fastening element, the physical properties of the case or sheet workpieces, and so on. On the other hand, as the speed of screwing increases, the productivity increases, which is important in mass production.

Calculating all combinations of the parameters of threaded joints is a complex and extensive task. A number of all combinations reaches several thousand. Therefore, in the context of this work, the task optimal management for the following joints was solved: screws with diameters of 3 to 6 mm, thread pitches from 0.5 to 1.5 mm, and for four materials (aluminium, textolite, organic glass, and polystyrene). The diameter of the screw within the specified limits does not significantly affect the torque, therefore, this factor was neglected when developing the experimental model of the target function (1).

So, the reliability of the process should be ensured by the following system of conditions:

$$\begin{cases}
 \delta_{\min} < \delta < \delta_{\max}; \\
 \delta \rightarrow \eta(\delta) = 0,7 - 0,85; \\
 \gamma < [\gamma]; e < [e]; \\
 \Delta M \rightarrow 0; \\
 M_t < [M]; \\
 P_O \geq P_H; \\
 \sigma_{Pt} > k_3 \times \sigma_{Tk}; \\
 V \geq V_H \quad t \leq t_H,
 \end{cases} \quad (6)$$

where δ_{\min} , δ_{\max} are limit calculated values of allowances for threading; $\eta(\delta)$ is the coefficients of thread completeness of thread in the allowance function; $[\gamma]$, $[e]$ are the limiting values of the angular and radial error with respect to orientation; ΔM is the oscillations of torque during assembly; $[M]$ is the limit value of the moment of cutting the fastener rod; P_o , P_H are the axial force and the force of engagement at the starting moment of assembly; σ_{Pt} is the yield point of the material of the fastener rod; k_r is the strength factor; σ_{Tk} is the yield

point of the case material; V_B is the end speed of engagement.

The target function was calculated for every thread pitch, screwing speed, and for various screwing lengths l/d .

Then the matrix of the values of the target function was compiled and the minimum in each column was found. Subsequently, some screwing speeds were sampled at these minimum values. The results were processed in the Excel environment to obtain regression coefficients.

The speed of screwing was calculated according to the following formula:

$$V_{opt} = b_0 + b_1 \times l/d + b_2 \times (l/d)^2 + b_3 \times P + b_4 \times P^2$$

where $b_0 \dots b_4$ are the regression coefficients (table 4); l/d is the length of screwing/длина свинчивания; P is the thread pitch, N_m .

Let the control law be deduced taking the calculation of the assembly joint as the example. The joint characteristics are the following –M5 standard screw with the thread pitch $P=1$ mm that is crewed in the case made of the Al4 alloy. The screwing length $l/d=1,5$.

Table 4. The coefficient of equations of the regression levels for calculating the speed of screwing the case-type workpieces

Material	Thread pitch P, mm	b_0	b_1	b_2	b_3	b_4
aluminium	0,5	12,733	0,0129	0,0005	-25,623	0,441
	1,0	24,435	0,0188	-0,0008	-2,616	-21,780
	1,5	1723,387	0,0263	0,0015	-971,649	-118,169
textolite	0,5	-13,908	0,0785	-0,0324	28,185	-0,766
	1,0	-6,021	0,0940	-0,0388	0,445	5,570
	1,5	321,160	0,0703	-0,0291	-181,022	-22,053
organic glass	0,5	4,188	0,0254	-0,0071	-8,445	0,201
	1,0	-3,919	0,0710	-0,0285	0,280	3,639
	1,5	533,203	0,0738	-0,0276	-300,601	-36,579
polystyrene	0,5	5,747	0,0115	-0,0009	-11,601	0,290
	1,0	7,226	0,0426	-0,0139	-0,915	-6,303
	1,5	420,339	0,0515	-0,0183	-236,954	-28,845

The torques at the speed of screwing from 0,0209 to 0,0731 m/s (from 80 to 280 rpm, respectively) and for various ratios l/d – from 0.5 to 1.5 are calculated according to the formula (4). The first value $l/d = 0.5$

corresponds to two turns of the screwed thread. From this moment the process of engagement is completed and the stable screwing of the fastener starts. Table 5 shows the results of the calculation of torques.

Table 5. Torques for M5screw, thread pitch $P=1$ mm, case Al4

l/d		0,5	0,66	0,83	1	1,16	1,3	1,5	
M_t , Nm	V, m/s	0,0209	12,22	13,21	14,76	16,81	19,18	21,63	25,71
		0,0296	11,49	12,39	13,83	15,77	18,05	20,41	24,37
		0,0383	11,09	11,86	13,16	14,96	17,11	19,36	23,16
		0,047	11,00	11,61	12,74	14,37	16,37	18,48	22,07
		0,0557	11,22	11,64	12,57	14,01	15,81	17,75	21,11
		0,0644	11,76	11,96	12,66	13,86	15,44	17,19	20,28
		0,0731	12,62	12,61	13,01	13,93	15,31	16,80	19,57

The target function is used to find optimum parameters of assembly and minimum values S are sampled. Table 6 shows the calculated values of the target function for thread pitches $P = 1$ mm and $P = 1,5$ mm. The second part of the table is designed for optimizing as these data will be used to build the optimization fields.

The optimization matrices are built on the basis of table 6. The first matrix comprises the values from the first columns for the thread pitch $P = 1$ and $P = 1,5$ mm, the second matrix comprises the values from the second columns, and so on. The matrices were processed with the help of MathCad 8.0. Fig. 4 shows the fields and surfaces

of the optimization, where $S_1 \dots S_7$ are the values of the target function at $l/d = 0,5 \dots l/d = 1,5$ respectively.

The graphs clearly show the dependence of the target function on the speed of screwing and thread pitches. As a number of turns of the screwed thread increases, the minimum (painted in blue) shifts toward the maximum values of the screwing speed. The minimum is slightly shifted in the opposite direction for the last turns.

The speed values at the minima of the target function are optimal but have the random distribution law; so, such control is difficult for implementation on a screwing machine. To obtain an acceptable curve, the calculation should be made according to the formula (7).

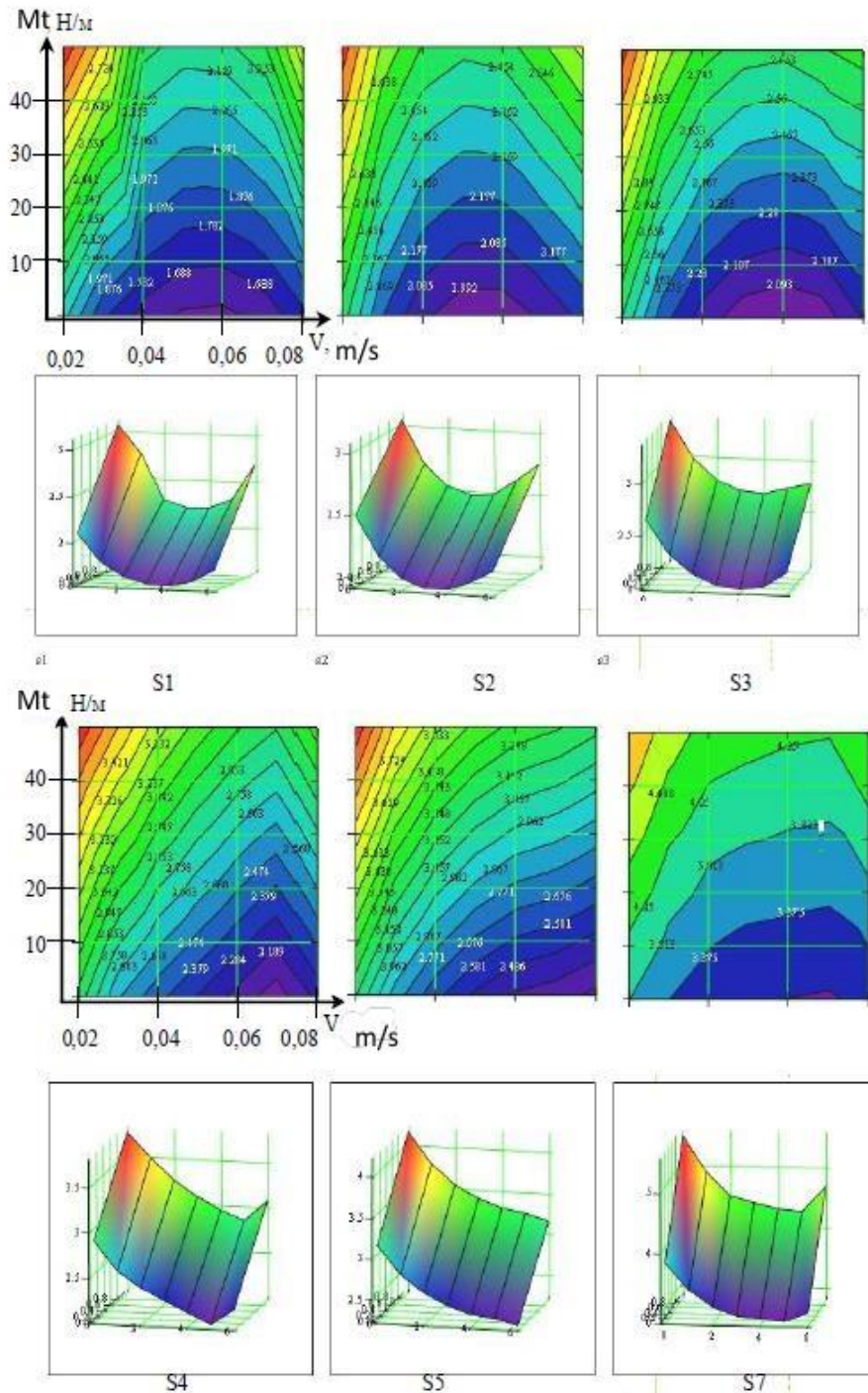

Fig. 4. Fields and optimization surfaces of the target function

Table 6. The values of the target functions for screws $d=5$, material A14

P , mm		1,0						
l/d , mm		0,5	0,66	0,83	1,0	1,16	1,3	1,5
S	V1	2,53	2,48	2,67	2,92	3,20	3,49	3,98
	V2	2,28	2,17	2,35	2,59	2,87	3,16	3,65
	V3	1,91	2,00	2,17	2,40	2,68	2,96	3,45
	V4	1,85	1,93	2,08	2,29	2,55	2,83	3,30
	V5	1,86	1,91	2,04	2,23	2,48	2,74	3,20
	V6	1,93	1,96	2,05	2,22	2,44	2,69	3,11
	V7	2,06	2,06	2,12	2,25	2,45	2,66	3,06
P , mm		1,5						
S	V1	2,74	3,01	3,35	3,76	4,18	4,60	5,27
	V2	2,45	2,70	3,02	3,41	3,83	4,25	4,91
	V3	2,31	2,54	2,84	3,21	3,62	4,02	4,67
	V4	2,27	2,47	2,74	3,09	3,47	3,85	4,47
	V5	2,31	2,47	2,71	3,01	3,36	3,71	4,30
	V6	2,42	2,53	2,72	2,98	3,28	3,60	4,14
	V7	2,66	2,72	2,87	3,07	3,32	3,58	4,71

Control actions are realized with the help of the diagram (fig. 1) which supplies the voltage which corresponds to the optimum screwing speed to the motor of the screwing head.

Conclusions

On the basis of the conducted researches, the stages of the control action development in the process of

managing the assembly and ensuring the parameters of the obtained joints were analyzed. In the course of the experimental studies, it was found that the following factors have the greatest impact on the torque – the speed of screwing, the thread pitch, the hardness of the housing material, the diameter of the threaded rod. The empirical formulas of torques are determined depending on the determining factors.

References

- Butkin, N. S. (1974), Investigation of interchangeability, manufacturability and quality of smooth-threaded joints: dissertation [Issledovanie vzaimozamenjajemosti, tehnologichnosti i kachestva gladko-rez'bovyh soedinenij: dis. ... Kand. tehn. nauk]. Moscow: MAI. 252 p.
- Zelenov, L. M. (1979), "Foreign Fasteners" ["Zarubezhnye krepzhnye izdelija"]. *Avtomobil'naja promyshlennost'*. No. 8. P. 31-32.
- Ivanova, V. M., Kalinina, V. N., Neshumova, L. A. and others (1981), *Math statistics [Matematicheskaja statistika]*. Moscow: Vyssh. shk. 371 p.
- Labeckij, V. M. (1976), Investigation of the process of thread formation and production of threaded joints by means of extruding rods: dissertation [Issledovanie processa formirovanija rez'by i poluchenie rez'bovyh soedinenij s pomoshh'ju vydavlivajushhih sterzhnej: dis. ... kand. tehn. nauk]. Barnaul. API named after I. I. Polzunova. 191 p.
- Kolombet, E. A. (1991), *Microelectronic means for processing analog signals [Mikrojelektronnye sredstva obrabotki analogovyh signalov]*. Moscow: Radio i svjaz'. 376 p.
- Novik, F. S., Arsov, A. B. (1980), *Optimization of the processes of metal technology by the method of planning experiments [Optimizacija processov tehnologii metallov metodom planirovanija jeksperimentov]*. Moscow: Mashinostroenie. Sofija. Tehnika. 304 p.
- John, R., Jones, S. (1997), "The economic Relevance of materials joining technology". *Welding World*. Vol. 39. No. 3. P. 145-153.
- Huhnert, T. (1995), "Systems for determining the coefficient of friction as the most important quality feature of screw mounting" ["Systeme zur Ermittlung des Reibwertes als wichtigstes Qualitätsmerkmal der Schraubmontage"]. *Machine*. No. 6-7. P. 30-31.
- "Right for the job: Advertising company Taumel Assembly Systems (NJ)". *Automation*. March. 1990. Vol. 3. P. 56.
- "Inserts to repair a variety of thread sizes". *Modern machine Shop*. 1997. Vol. 70. No. 1. P. 284-287.

Received 05.09.2017

Скоркін Антон Олегович – кандидат технічних наук, доцент, Українська інженерно-педагогічна академія, доцент кафедри металоріжучого обладнання і транспортних систем, м. Харків, Україна; e-mail: Andromeda862@ukr.net; ORCID: 0000-0003-3032-8341.

Skorkin Anton Olegovich – кандидат технических наук, доцент, Украинская инженерно-педагогическая академия, доцент кафедры металлорежущего оборудования и транспортных систем, г. Харьков, Украина; e-mail: Andromeda862@ukr.net; ORCID: 0000-0003-3032-8341.

Skorkin Anton – PhD (Engineering), Associate professor, Ukrainian Engineering Pedagogics Academy, Associate professor of the Department of Metal-cutting equipment and transport systems, Kharkiv, Ukraine; e-mail: Andromeda862@ukr.net; ORCID: 0000-0003-3032-8341.

Кондратюк Олег Леонідович – кандидат технічних наук, доцент, Українська інженерно-педагогічна академія, доцент кафедри металоріжучого обладнання і транспортних систем, м. Харків, Україна; e-mail: mot@uipa.edu.ua; ORCID: 0000-0002-3263-0483.

Кондратюк Олег Леонидович – кандидат технических наук, доцент, Украинская инженерно-педагогическая академия, доцент кафедры металлорежущего оборудования и транспортных систем, г. Харьков, Украина; e-mail: mot@uipa.edu.ua; ORCID: 0000-0002-3263-0483.

Kondratyuk Oleg – PhD (Engineering), Associate professor, Ukrainian Engineering Pedagogics Academy, Associate professor of the Department of Metal-cutting equipment and transport systems, Kharkiv, Ukraine; e-mail: mot@uipa.edu.ua; ORCID: 0000-0002-3263-0483.

ОСНОВНІ ПРИНЦИПИ КОМПЛЕКСНОГО УПРАВЛІННЯ СКЛАДАЛЬНО-РІЗЬБОУТВОРЮЮЧИМ ПРОЦЕСОМ

Предметом дослідження в даній статті є питання, пов'язані з комплексним управлінням операціями зборки кріпильно-різьбоутворюючих елементів на всіх етапах їх здійснення. **Мета** – розробка узагальненої структури інформаційно-керуючої системи складально-різьбоутворюючим процесом. **Завдання:** обґрунтування принципів управління складально-різьбоутворюючі процесом на кожному з етапів реалізації збірки для підвищення ефективності даних операцій, досліджувати силові, точності і експлуатаційно-технічні характеристики з'єднань і зробити висновок про ефективність запропонованої теорії управління складанням. Отримані наступні **результати**. У статті представлені аналітичні залежності силових показників різьбоутворення при складанні в корпус і лист, в тому числі і зусилля затяжки з'єднання, проаналізовано збірка багат шарового пакета різнорідних листових матеріалів. На основі теоретичного аналізу отримано залежності силових показників різьбоутворення при складанні в корпусний і листовий матеріал. Досліджено збірку пакета листових матеріалів, включаючи багат шаровий пакет з різнорідних матеріалів типу "метал-пластмаса". **Висновки**. Досліджено процес складання різьбових з'єднань з використання принципів управління, які дозволяють підвищити ефективність складального процесу, знизити трудомісткість основних операцій, поліпшити якість одержуваних сполук. Для зниження крутять моментів запропоновано використовувати адаптивне управління швидкістю загвинчування на основних переходах різьбоутворення. Розроблено технологію отримання різьбових з'єднань із заданими властивостями, визначені основні шляхи підвищення ефективності складально-різьбоутворюючих процесів на основі комплексної системи управління складальним процесом.

Ключові слова: складання, кріпильні елементи, різьбоутворюючий процес, крутний момент.

ОСНОВНЫЕ ПРИНЦИПЫ КОМПЛЕКСНОГО УПРАВЛЕНИЯ СБОРОЧНО-РЕЗЬБООБРАЗУЮЩИМ ПРОЦЕССОМ

Предметом исследования в данной статье являются вопросы, связанные с комплексным управлением операциями сборки крепежно-резьбообразующих элементов на всех этапах их осуществления. **Цель** – разработка обобщенной структуры информационно-управляющей системы сборочно-резьбообразующим процессом. **Задачи:** обоснование принципов управления сборочно-резьбообразующим процессом на каждом из этапов реализации сборки для повышения эффективности данных операций, исследовать силовые, точностные и эксплуатационно-технические характеристики соединений и сделать вывод об эффективности предлагаемой теории управления сборкой. Получены следующие **результаты**. В статье представлены аналитические зависимости силовых показателей резьбообразования при сборке в корпус и лист, в том числе и усилие затяжки соединения, проанализирована сборка многослойного пакета разнородных листовых материалов. На основе теоретического анализа получены зависимости силовых показателей резьбообразования при сборке в корпусный и листовой материал. Исследована сборка пакета листовых материалов, включая многослойный пакет из разнородных материалов типа "металл-пластмасса". **Выводы**. Исследован процесс сборки резьбовых соединений с использованием принципов управления, которые позволяют повысить эффективность сборочного процесса, снизить трудоемкость основных операций, улучшить качество получаемых соединений. Для снижения крутящих моментов предложено использовать адаптивное управление скоростью завинчивания на основных переходах резьбообразования. Разработана технология получения резьбовых соединений с заданными свойствами, определены основные пути повышения эффективности сборочно-резьбообразующих процессов на основе комплексной системы управления сборочным процессом.

Ключевые слова: сборка, крепежные элементы, резьбообразующий процесс, крутящий момент.