

K. VASYUTA, F. ZOTS, I. ZAKHARCHENKO

BUILDING THE AIR DEFENSE COVERT INFORMATION AND MEASURING SYSTEM BASED ON ORTHOGONAL CHAOTIC SIGNALS

The **subject matter** of the paper is a covert information and measuring system based on orthogonal chaotic signals. The **goal** of the work is to synthesize a covert information measuring system built on the basis of orthogonal chaotic signals. The **tasks** to be solved included assessing the potential for organizing multi-channel capacity using chaotic carriers; studying the ways of application of chaotic signals in the wireless systems of data transmission; synthesizing the general structure of MIMO radar system based on the orthogonality of chaotic signals. General scientific and special research **methods** were used while conducting the research, in particular, the system analysis and mathematic modelling. The following **results** were obtained. The concept of building a net-centric multi-radar information measuring system (MIMS) on the basis of the specific properties of chaotic signals (processes) is proposed in the paper. It is shown that the use of orthogonal chaotic signals for detecting air targets and transmitting information about them increases noise immunity, resolution characteristics and transmission capacity; enables providing electromagnetic compatibility and separating information-detecting and transmitting channels. MIMS block diagram is synthesized. **Conclusions.** Specific properties of chaotic signals make it possible to apply them to build data transmissions systems according to the MIMO principle and multichannel radars. Based on chaotic signals, a multiradar information measuring system can be built. The above techniques can be implemented to build a network of unattended radars as well as in multichannel communication systems. They can be applied to control air traffic and can be used in the air defence net-centered systems to create common covert information and telecommunication space.

Keywords: chaotic signals; signal-code sequence; MIMO-technology; information-measuring system.

Introduction

The transition from a top-down vertical control system to global net-centric control systems on the basis of information measuring systems enable comprising the networks of control, reconnaissance and telecommunication, the combat networks of high-precision weapons, that operate on a real time, which allows the troops to act much faster and more efficiently [1].

Such nets can be built using new types of complex signals [2, 3], on the basis of new technologies of signal and data digital processing [4] as well as on unconventional ways of coordinate-time support and synchronization while interchanging among these nets at the signal and information levels.

Signals applied in such nets should ensure high noise immunity and resolution characteristics, sufficient transmission capacity, the capability of organizing multiple data transmitting channels and electromagnetic compatibility. The shape of these signals determines the operational security of the information measuring system.

The analysis of recent studies and publications

The discovery on the possibility of synchronizing two sources of chaotic oscillations made by L. Pecora and T. Carrol resulted in the use of chaotic signals for telecommunication systems. The possibility of synchronizing irregular oscillations became the basis for the assumption that chaotic oscillations can be used as carriers of information messages (chaotic carriers). The properties of chaotic carriers are rather well described in the literature [5-19], etc., where the authors show that chaotic oscillations can be found in various nonlinear

dynamic systems since chaotic signals, as information carriers, have a number of unique properties that distinguish them from traditional information carriers, and offer various approaches to the transmission of information on a chaotic carrier. The possibility of organizing covert (confidential) communications is of particular interest in systems with a chaotic carrier. However, the use of chaotic signals to build a covert information-measuring system for air defense purposes has a number of specific features.

Thorough attention to the specified issues has determined the goal of this paper that is to synthesize a covert information measuring system built on the basis of orthogonal chaotic signals.

The discussion of the results of the study

Assessing the multi-channel potentiality using chaotic signals

The quantitative assessment of the multi-channel potentiality using chaotic signals will be carried out by mathematical modelling of the correlation reception of a chaotic signal that is in the group signal which includes N chaotic implementations:

$$S(t) = \sum_{i=1}^N x_i(t), \quad (1)$$

where S is a mixture of chaotic oscillations being observed; x_i is the implementation of a chaotic signal that corresponds to the i -th channel of data transmission from N probable ones.

To generate chaotic processes, Chebyshev mapping of the 1st type of 3rd order is used:

$$x_{n+1} = 4(x_n)^3 - 3x_n \tag{2}$$

Initial conditions x_0 y in mapping (2) were given within the interval $x_0 \in (0;1)$. The initial conditions were selected sequentially by the following expressions:

$$x_i = 0.1 \cdot i \quad i = 1...9; \tag{3}$$

$$x_i = 0.01 \cdot i \quad i = 1...99; \tag{4}$$

$$x_i = 0.001 \cdot i \quad i = 1...999 \tag{5}$$

For the quantitative comparison of the correlation functions obtained under different initial conditions, the concept of the coefficient is introduced

$$K_{CF} = \frac{\max\{CF_{\tau \neq 0}\}}{CF_{\tau=0}}, \tag{6}$$

where $CF_{\tau=0}$ is the readout of the correlation function of chaotic processes that are compared when one implementation is shifted relative to the other one at $\tau = 0$; $\max\{CF_{\tau \neq 0}\}$ is the maximum value of the readout of the correlation function at $\tau \neq 0$ (fig. 1).

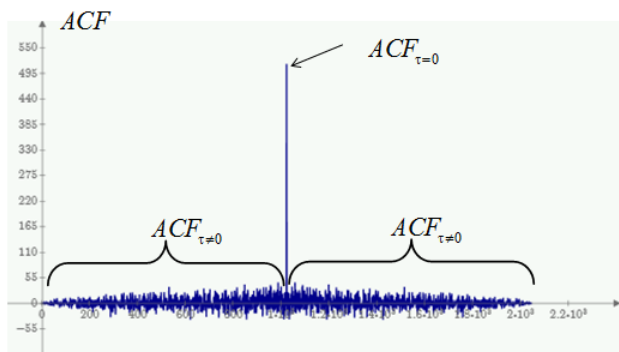

Fig. 1. Autocorrelation function of chaotic oscillations for Chebyshev mapping of the 1st type of 3rd order

The correlation function given in fig. 1 can be presented as follows (fig. 2).

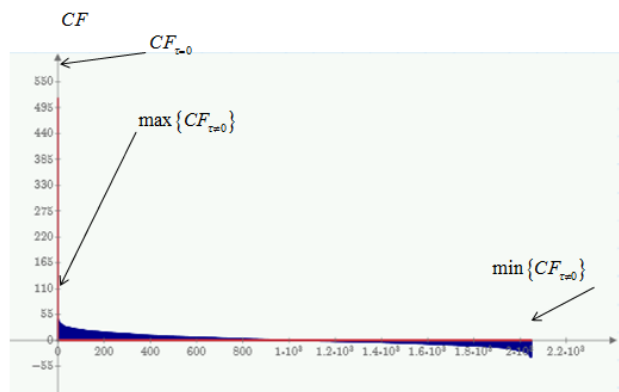

Fig. 2. The correlation function of two chaotic oscillations after conversion

It looks like this after all readouts $CF_{\tau \neq 0}$ have been ranked in the descending order from $\max\{CF_{\tau \neq 0}\}$ to $\min\{CF_{\tau \neq 0}\}$. The coefficient K_{CF} will lie within the interval $K_{CF} \in (-\infty; \infty)$ is $\max\{CF_{\tau \neq 0}\} \neq 0$. The correlation function is considered as satisfactory if $K_{CF} < 0.5$, that is if the value $\max\{CF_{\tau \neq 0}\}$ is not greater than half of the value $CF_{\tau=0}$.

Then, a group chaotic signal consisting of a mixture of chaotic implementations was modelled according to the expression (1) where there was no additive noise. A number of chaotic implementations N in the mixture changed from 1 to 179.

		j																																																																																																																																						
		0.087	0.143	0.156	0.186	0.219	0.233	0.222	0.246	0.265	0.323	0.342	0	0.131	0.175	0.199	0.175	0.216	0.264	0.272	0.245	0.269	0.291	0	0	0.138	0.154	0.175	0.212	0.227	0.238	0.262	0.342	0.398	0	0	0	0.182	0.215	0.232	0.253	0.276	0.244	0.24	0.253	0	0	0	0	0.241	0.236	0.258	0.304	0.338	0.347	0.399	0	0	0	0	0	0.243	0.275	0.262	0.315	0.281	0.282	0	0	0	0	0	0	0.278	0.301	0.312	0.273	0.321	0	0	0	0	0	0	0	0.229	0.288	0.309	0.337	0	0	0	0	0	0	0	0	0.28	0.312	0.291	0	0	0	0	0	0	0	0	0	0	0.293	0.289	0	0	0	0	0	0	0	0	0	0	0	0.278	0	0	0	0	0	0	0	0	0	0	0	0
res2 =	i															i																																																																																																																								

Fig. 3. A fragment of the matrix of correlation reception coefficients

The elements of the matrix are the values of correlation reception coefficients $K_{CF(i,j)}$, where i is the reference value of the chaotic implementation, j is a number of chaotic implementations in a group signal ($j = 1..N$).

The results of the correlation reception of the separate chaotic process n in a group signal that consists of N chaotic implementations (N channels) with a fixed number of discrete readouts of a signal are represented as a matrix of correlation reception coefficients K_{CF} (fig. 3). Since the order of the chaotic implementations in a group signal does not matter, the matrix has a triangular shape. To make the visual analysis of the coefficient matrix $K_{CF(i,j)}$ easier in general, especially when the dimension of the matrix is large, it should be presented graphically, where the elements of the matrix whose values are greater than 0.5 are presented in black, if the values are less than 0.5 – in white, zero elements (which are not analyzed) are presented in grey.

When a number of implementations in a group signal ($N=15$) but a number of readouts remain the same (1024), there appear black colour in the matrix (fig. 5), that means that satisfactory correlation reception, in this case, becomes impossible.

Fig. 4 shows the results of correlation reception of separate chaotic oscillations in the group signal with 14 chaotic implementations with 1024 discrete readouts ($N=14$).

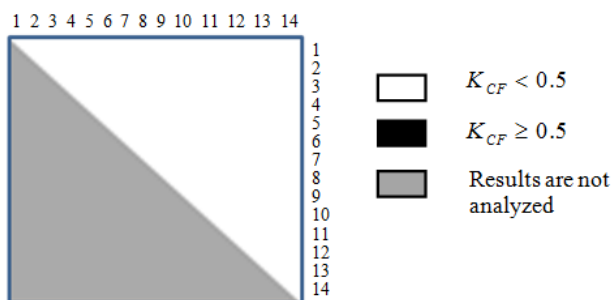

Fig. 4. The graphical matrix of the quality of the correlation reception of separate chaotic oscillations in the group signal with 14 chaotic implementations with 1024 discrete readouts



Fig. 5. The graphical matrix of the quality of the correlation reception of individual chaotic implementations from the group signal ($N = 15$) for 1024 discrete readouts

When a number of implementations j in a group signal continues to increase, the quality of the matrix becomes worse. Fig. 5 shows such a matrix when $N = 21$ and $N = 26$.

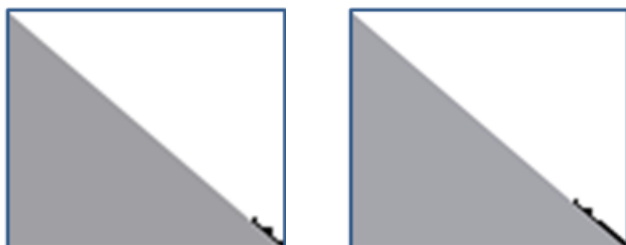

Fig. 6. The graphical matrix of the quality of the correlation reception of separate chaotic implementations from the group signal at $N = 21$, $N = 26$ for 1024 discrete readouts

For further increasing a number of implementations $N > 14$ in a group signal and a number of channels respectively, a number of discrete readouts of chaotic implementations should be increased (greater than 1024).

It should be noted that the increase of a number of readouts of chaotic implementations is limited by the capabilities of digital analogue transducers. Therefore, additional methods for increasing a number of data transmission channels should be found. For this purpose, the orthogonal properties of chaotic realizations in vector space are considered in details. Two vectors in multidimensional space are known to be orthogonal if scalar product is zero [20].

$$\mathbf{X}_i \bullet \mathbf{X}_{i+1} = 0 \quad (7)$$

Let the orthogonality of the obtained group of chaotic realizations be checked. To do this, the scalar products among all probable combinations of pairs of vectors (chaotic realizations) are calculated. The obtained results are presented graphically in fig. 7, where the scalar product $\mathbf{X}_i \bullet \mathbf{X}_{i+1} \neq 0$ is presented in black, $\mathbf{X}_i \bullet \mathbf{X}_{i+1} = 0$ – in white, сірим – results that are not analyzed are presented in grey.



Fig. 7. The graphical matrix of scalar products between pairs of vectors of chaotic implementations

The analysis of fig. 7 shows that chaotic signals are not orthogonal, that is, the value of angles between the pairs of vectors (chaotic implementations) is not 900.

The values of angles among all probable pairs of vectors (chaotic implementations) for a group signal ($N = 179$) was calculated by the expression:

$$\phi = \arccos \left(\frac{\bar{a} \cdot \bar{b}}{|\bar{a}| \cdot |\bar{b}|} \right) \quad (8)$$

where b is vector \mathbf{X}_i , a is vector \mathbf{X}_{i+1} ,

Fig. 8 shows the angle dispersion graph σ^2 among all pairs of vectors for various numbers of readouts of chaotic implementations (K).

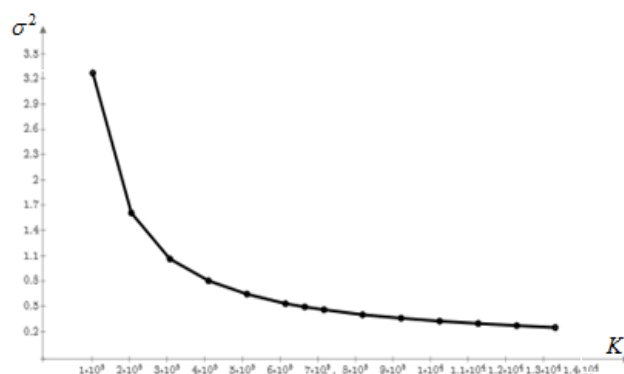

Fig. 8. The dispersion of angles between pairs of chaotic realizations for different numbers of readouts K

The graph shows that when a number of discrete readouts of chaotic implementations increases, the dispersion decreases.

Fig. 9 shows the average values of angles between the pairs of vectors for various numbers of discrete readouts.

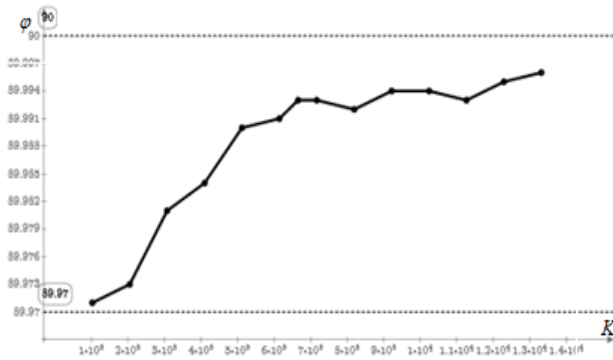

Fig. 9. The value of the average value of the angles between pairs of chaotic implementations for various numbers of readouts K

It is seen that the angles between vectors are not 90^0 although are close to this value. That means that chaotic implementations are quaziorthogonal.

To increase a number of chaotic implementations in a group signal, they should be orthogonalized by one of the known methods. Work [20] suggests using Gram-Schmidt algorithm, which points that on the basis of a set of linear independent vectors $a_1...a_N$, a set of orthogonal vectors $b_1...b_N$ is built, where each vector b_j can be represented by the linear combinations of vectors $a_1...a_j$. To perform this operation, the project operator is introduced:

$$\text{Pr } og_b a = \frac{\langle a, b \rangle}{\langle b, b \rangle} \cdot b, \quad (9)$$

where $\langle a, b \rangle$ is the scalar product of vectors a and b . The procedure of orthogonalization is as follows:

$$a_1 = b_1; \quad (10)$$

$$b_N = a_N - \sum_{j=1}^{N-1} \text{Pr } og_{b_j} a_N. \quad (11)$$

Fig. 10 shows the results of the use of the Gram-Schmidt orthogonalization of a group of chaotic implementations obtained by the expression (4) at $N = 179$.



Fig. 10. The graphical matrix of scalar products between pairs of vectors of chaotic implementations after orthogonalization

After that, the correlation reception of the separate chaotic process n from the mixture N of orthogonal chaotic implementations was modelled. ортогональних хаотичних реалізацій. The correlation reception of 14

chaotic implementations in a group signal, where there are 1024 readouts, was modelled at first. It was found that satisfactory reception of 15 chaotic implementations without increasing a number of readouts is impossible. After that, the procedure of orthogonalization was performed, which enabled increasing a number of received chaotic implementations up to 21. Later, discrete readouts increased up to 1024 every time when the procedure of orthogonalization became inefficient. The maximal number of discrete readouts when modelling was limited by PC computing capabilities was 13312; this enabled the correlation reception of 120 chaotic implementations in a group signal without orthogonalization.

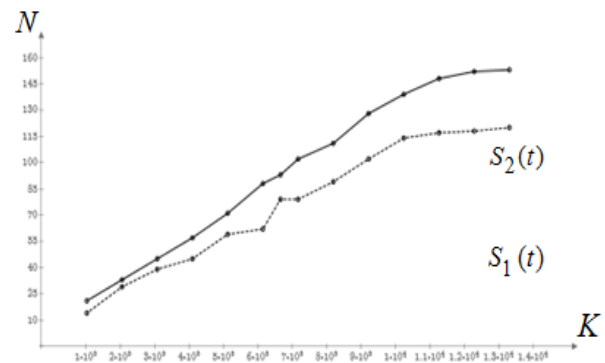

Fig. 11. The dependence of a number of chaotic implementations in a group signal on a number of discrete readouts to $S_1(t)$ and after $S_2(t)$ orthogonalization

Orthogonalization enabled ensuring the satisfactory correlation reception of 153 chaotic implementations.

Fig. 11 shows the curves that represent the changes of the maximal number of chaotic implementations in a group signal to $(S_1(t))$ and after $(S_2(t))$ orthogonalization for the various number of signal discrete readouts. Graphs show that orthogonalization enables increasing a number of chaotic implementations in a group signal, in other words – increasing a number of data transmission channels.

Further studies should be carried out to increase the bandwidth capacity of data transmission systems by creating chaotic signal constellations.

The formation of chaotic signal-code constructions

In particular, their quaziorthogonal properties enable organizing the code division of chaotic sequences in a group signal. But the task of designing signal constellations and signal – code constructions, using chaotic signals, is not sufficiently investigated [21]. The traditional approach to the transmission of chaotic signals involves the formation of two chaotic sequences $x_1(t)$ – "0", $x_2(t)$ – "1" for the sequential transfer of bit streams. The property of the quaziorthogonality of chaotic signals enables making a transition from sequential transmission to parallel transmission. This enables reducing the time of the message transmission in m times.

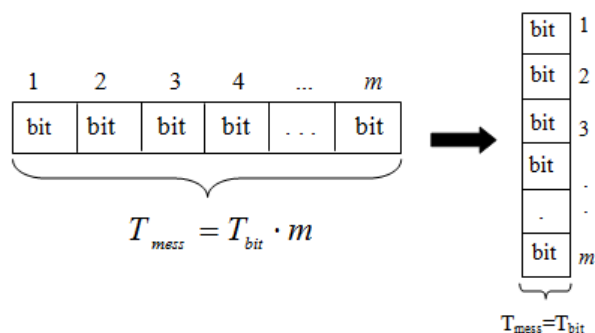

Fig. 12. Transition from sequential to parallel bit transmission

To do this, each bit is transmitted by a separate sequence of the chaotic process, orthogonal to one from the set m . Thanks to the parallel transmission, all bits are received at the same time, therefore the order of their follow-up cannot be distinguished. To eliminate this disadvantage, it is proposed to generate separate chaotic sequences specific to "0" and "1" in the corresponding position in the message. The initial value x_{ij} of the formation of the chaotic sequences (fig. 13) is a code that uniquely indicates the direct value of the bit ("0" or "1") and simultaneously indicates the "location" of each bit in the sequence (its serial number).

The informational message, formed in this way, is a superposition of chaotic sequences, duration $T_{bit}(1)$.

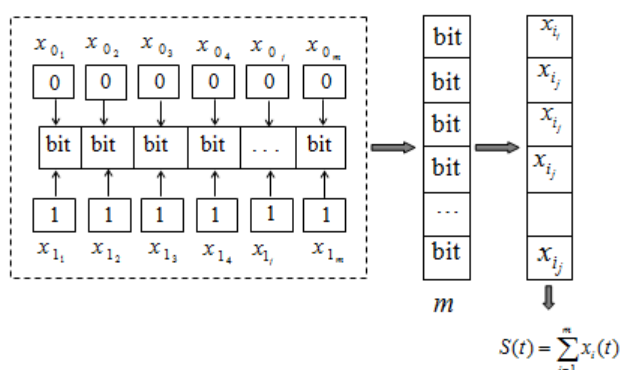

Fig. 13. The coding scheme of bit sequence using the initial values of chaotic sequences

The rule for selecting the initial values for generating chaotic sequences is given in table 1.

Table 1. The rule for selecting the initial values

Bit	Initial values x_{ij} (code) to generate chaotic sequences in accordance with the order of binary symbols						
	1	2	3	4	5	...	m
"0"	x_{01}	x_{02}	x_{03}	x_{04}	x_{05}	x_{0i}	x_{0m}
"1"	x_{11}	x_{12}	x_{13}	x_{14}	x_{15}	x_{1i}	x_{1m}

where x_{ij} is the initial value, i is the value of a binary symbol ("0" or "1"), j is a serial number in the sequence.

In the receiving side, to make a decision about the value of the bit for each position of the received message

two hypotheses should be checked: H_{0j} – the presence of "0" and H_{1j} – the presence of "1" on the position in the message. The presence of other $m-1$ bits in the message leads to errors in making a decision in the general case of non-orthogonality of chaotic sequences.

To separate each of the m signals on the receiving side, m decision devices (fig. 14) are necessary.

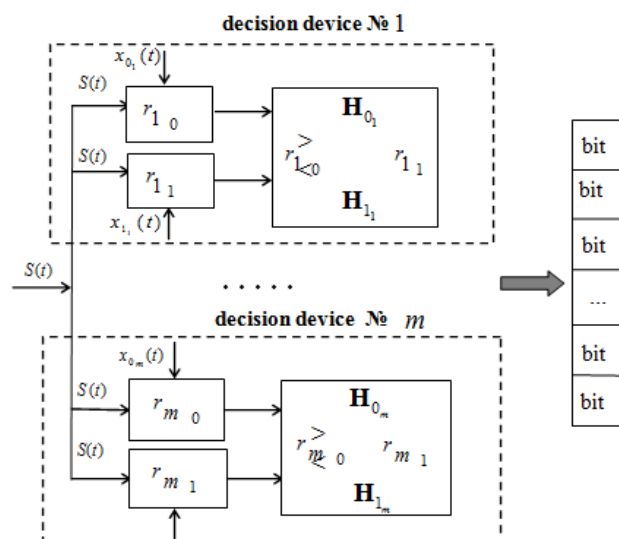

Fig. 14. The scheme of signal separation on the receiving side

The decision is made by calculating the Pearson correlation coefficient between the sequence from the receiver input $S(t)$ (1) and each of the standard chaotic sequences with the code x_{0j} and x_{1j} for the m -s decision device. The Pearson correlation criterion is a statistical parametric method for determining the degree of correlation between two variables.

The obtained correlation coefficients are compared with each other. Depending on which value the coefficient is greater, the hypothesis H_{0j} is accepted – the presence of "0" on the j -s position or H_{1j} – the presence of "1" on the j -s position. As a result of the selected hypotheses, the parallel sequence of bits of the received message in the m outputs of the decision devices is obtained.

Mathematical modeling of the data transmission system using the proposed method was carried out in the work. As a carrier, chaotic sequences, obtained by the modified Chebyshev mapping (2) is considered.

The chaotic mode for the modified Chebyshev mapping is observed at an alpha value:

$$-1.00 < \alpha < -0.78 \tag{14}$$

$$0.78 < \alpha < 1.00 \tag{15}$$

and at the initial value

$$0.78 < \alpha < 1.00 \tag{16}$$

It should be noted that the general disadvantage of chaotic signals obtained with any kind of mappings is their low structural secrecy. The reason for this is

structured phase portraits or attractors that are images of chaotic signals in the pseudophase space. Traditional methods for determining energy and structural secrecy usually do not use the specific properties of attractors.

The messages transmission in a parallel way enables providing the structural secrecy of the chaotic signals that are used for transmission. A group chaotic signal, represented by a sum of 5 or more chaotic signals, has a phase portrait similar to the white noise portrait. Nonparametric methods (BDS-statistics) [19-22] do not determine the ordering and regularities between the points of the attractor of such signal.

The specific values of the control parameter and the initial values for generating chaotic sequences are conveniently graphically represented as the points of the signal constellation (fig. 15), where the axis of the abscissa denotes x_0 , the axis of the ordinate denotes α .

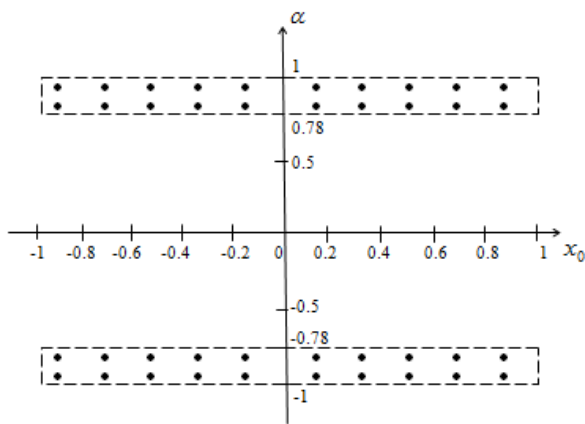

Fig. 15. Chaotic signal constellation

The group chaotic signal m bits long corresponds to a code combination of m points of a chaotic signal constellation, in accordance with Table 1 of the initial values.

Fig. 16 shows bit error ratio for the parallel transmission of messages using a chaotic sequences obtained by a modified Chebyshev mapping, at $K = 50, 100, 150$ discrete signal samples.

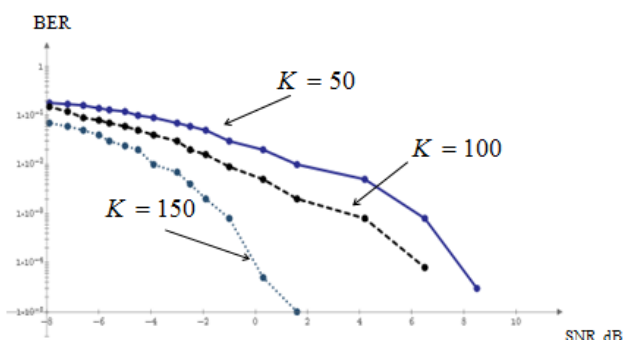

Fig. 16. Bit error ratio for the parallel transmission of messages using chaotic sequences obtained by a modified Chebyshev mapping at $K = 50, 100, 150$ discrete signal samples

In order to increase bit error ratio, an orthogonalization of chaotic sequences that were part of a group signal was carried out. For these purposes, the

Gram-Schmidt orthogonalization procedure [23] was carried out.

Fig. 17 shows bit error ratio for the parallel transmission of messages for orthogonal chaotic sequences based on the modified Chebyshev mapping at $K = 50, 100, 150$ discrete samples.

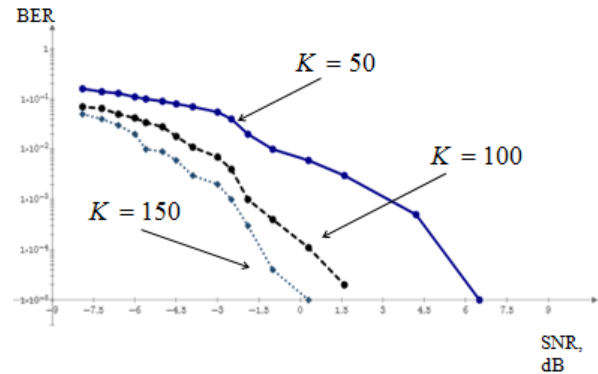

Fig. 17. Bit error ratio for the parallel transmission of messages using orthogonal chaotic sequences obtained by a modified Chebyshev mapping and the Gram-Schmidt orthogonalization procedure at $K = 50, 100, 150$ discrete signal samples

The use of noiseless coding is one of the most efficient ways to increase the reliability of receiving messages and reduce the probability of errors to some acceptable level. To do this, it is proposed to add control bits to the parallel bit packet. Additional orthogonal chaotic sequences are formed for their transmission in accordance with table 1.

Applied the Gram-Schmidt orthogonalization procedure can increase the reliability of receiving messages and provide a gain of about 1.5–2 dB for $P_{er} = 10^{-5}$, compared to the use of chaotic sequences without the orthogonalization procedure. In order to increase the structural secrecy of the formed group chaotic signal, which consists of more than 5 chaotic sequences, it is impractical to apply the methods of destroying the phase portrait, since the phase portrait of such a signal looks like a phase portrait of the white noise. The rejection of these methods will simplify algorithms for processing the group chaotic signal

Chaotic signals in wireless data transmission systems

At the moment, a large number of ways to use chaotic signals for data transmission have been proposed. However, chaotic signals (processes) used in such systems have structured (ordered) attractors (phase portraits) that distinguish them from noise.

In turn, the degree of the structuring of the attractor of a chaotic process determines its covertness.

When a third-party observer applies modern methods of nonlinear analysis [19], the probability of correct classification of observation (white noise or chaotic process) increases and the potential covertness of a chaotic signal decreases to the level caused by the noise of its observation. Therefore, to increase the covertness of a chaotic process, its attractor should be complicated, i.e. the degree of its structuring should be reduced.

Among the various possibilities of complicating the attractor of a chaotic process, the method of signal complexity by frequency filtering the chaotic carrier proposed in [24] can be distinguished. The analysis of the work shows that the attractor of a filtered chaotic signal is similar to the white noise attractor, which increases its covertness.

It should also be noted that the use of chaotic signals (processes) leads to the expansion of the spectrum of a transmitted signal and, as a result, to a decrease in the speed of information transfer when the bandwidth of the communication signal is limited. However, this problem is solved by applying the MIMO technology to a chaotic carrier [25] due to the implementation of a set of chaotic signals with various initial formation values.

Chaotic signals in radar systems

One of the promising ways of radar systems (RS) development is RS MIMO that have a number of advantages [26–28]. However, one of the problematic issues in building RS MIMO is channel division. Nowadays in RS MIMO, like in communication systems, frequency code and phase-shift signals. It is known that the diversity of code signals is limited, which, in the nearest future, will not enable ensuring the channel division of numerous radio electronic means (REM) within the limited frequency range. The above studies

show that chaotic signals are high sensitive to initial values while being formed; this feature enables forming a set of orthogonal chaotic signals in measuring systems. Due to this, when building an RS MIMO for channel division, orthogonal chaotic signals can be used, which also enables ensuring the electromagnetic compatibility (EMC) of different REMs on neighboring positions.

Based on the above feature of the orthogonality of chaotic signals, the general structure of such an RS MIMO is synthesized below; its diagram is given in fig. 18.

A setup unit (signal processor) is designed to form a set of chaotic radio pulses $X(x_0^{(k,l)})$ with various initial values $x_0^{(k,l)}$. Signals formed by the set up unit are amplified to the required power and fed to the pattern-forming circuit (PFC) as sounding signal and to the multi-channel information processing circuit (IPC) as expected signals. PFS implements the necessary variant of the space scanning. Signals in each beam are processed by multi-channel correlation filtering IPC.

The algorithm of radar information processing is synthesized in one channel, which corresponds to the given direction either in azimuth or elevation. In general, signals will be considered at the NM input, that is, elemental, flat, equally spaced phased array antenna (PAA) (N is a number of elementary emitters horizontally, M is a number of elementary emitters vertically (fig. 18).

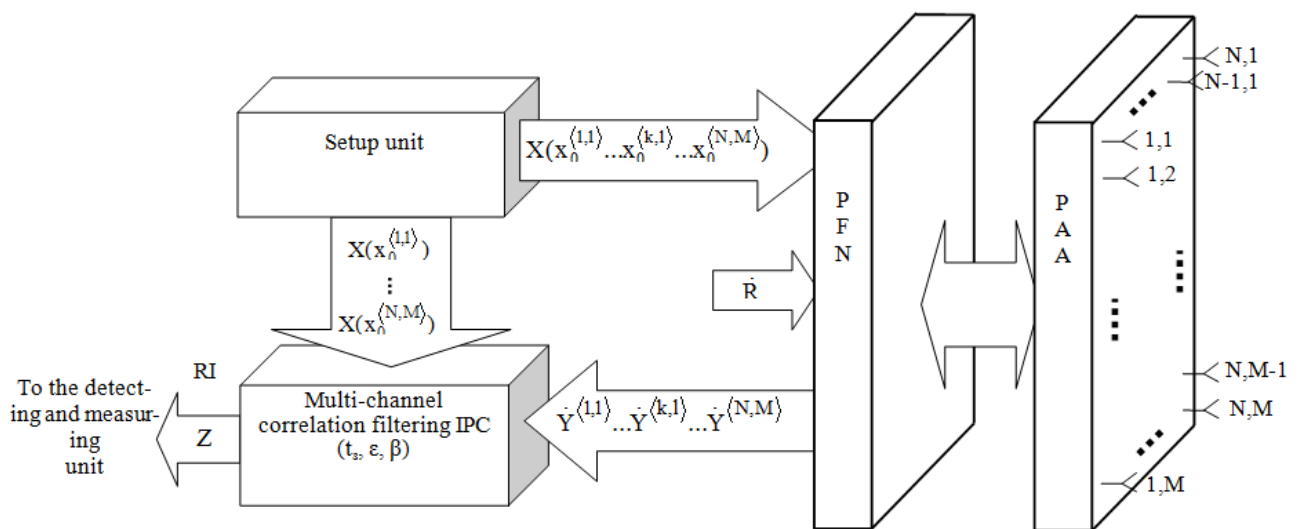

Fig. 18. The block diagram of the radar MIMO with the use of orthogonal chaotic carriers

Let signal $y_{n,m}$ received by the elemental emitter ($n \in 1 \dots N$ is the number of the emitter in the line, $m \in 1 \dots M$ is the number of the emitter in the column) be represented as discrete values of a continuous signal taken through the sampling period $\Delta t = \frac{1}{2f_{\max}}$, where f_{\max} is the maximum frequency in the signal spectrum. Complex oscillation amplitudes $\dot{y}_{n,m}$ received by n, m elements of PAA are subject to weighted summation in PFS, where at the output complex oscillation amplitudes $\dot{Y}^{(k,l)}$ are formed in k, l st spatial channel (partial beam) in the

general case $k \in 1 \dots N, l \in 1 \dots M$.

$$\dot{Y}^{(k,l)} = \sum_{n=1}^N \sum_{m=1}^M \dot{y}_{n,m} \dot{R}^{(k,l)} \quad (12)$$

where $\dot{R}^{(k,l)}$ is the k, l elements of the weight matrix \dot{R} . The specific values of the weight matrix are determined on the basis of a given width of the directional pattern of partial rays and their orientation in space with an acceptable level of side lobes. Thus, spatial signal processing is carried out in PFC, which is built on the basis of the known orthogonal Hadamard, Fourier

transformations, and so on. There is a set of time readouts $\dot{Y}^{(k,l)}$ at the output of every beam (12).

Later, the processing in each receiving channel is the same, only the expected signal $\dot{X}(x_0^{(k,l)}, t_s, F_D)$ differs. That meant that a bidirectional PAA emits and receives an orthogonal chaotic signal with its initial value $x_0^{(k,l)}$ in the given direction.

The indicators k, l that determine the number of a spatial channel ($\dot{Y}^{(k,l)} \rightarrow \dot{Y}$) are omitted for the sake of simplicity. Thus, further processing is not different from the traditional correlation processing of a chaotic signal, which is considered in [3] amid the reception under the white noise.

$$Z(t_s, F_D) = \frac{1}{2} \left| \int_{-\infty}^{\infty} \dot{Y}(t) \dot{X}^*(x_0, t-t_s, F_D) dt \right| \quad (13).$$

For the discrete values of complex oscillation amplitudes \dot{Y} at the PFS output, when a discrete values is l , $t = i\Delta t$, $t_s = j\Delta t$ and when the integral is changed for the sum in (2), the below expression is obtained:

$$Z_j(F_D) = \frac{1}{2} \left| \sum_{i=1}^l \dot{Y}_i \dot{X}_{i-j}^*(x_0, F_D) \right| \quad (14).$$

The formed values of the module of the weighted sum (14) on the detection device (comparison with the threshold) and measurement are presented in fig. 18.

Since the flat PAA enables proving parallel scanning of the space only in the specified sector in azimuth, several such PAA or a cylindrical one should be applied to scan the space simultaneously in all azimuth directions.

The variant of scanning the space with the use of a cylindrical PAA is given in fig. 19.

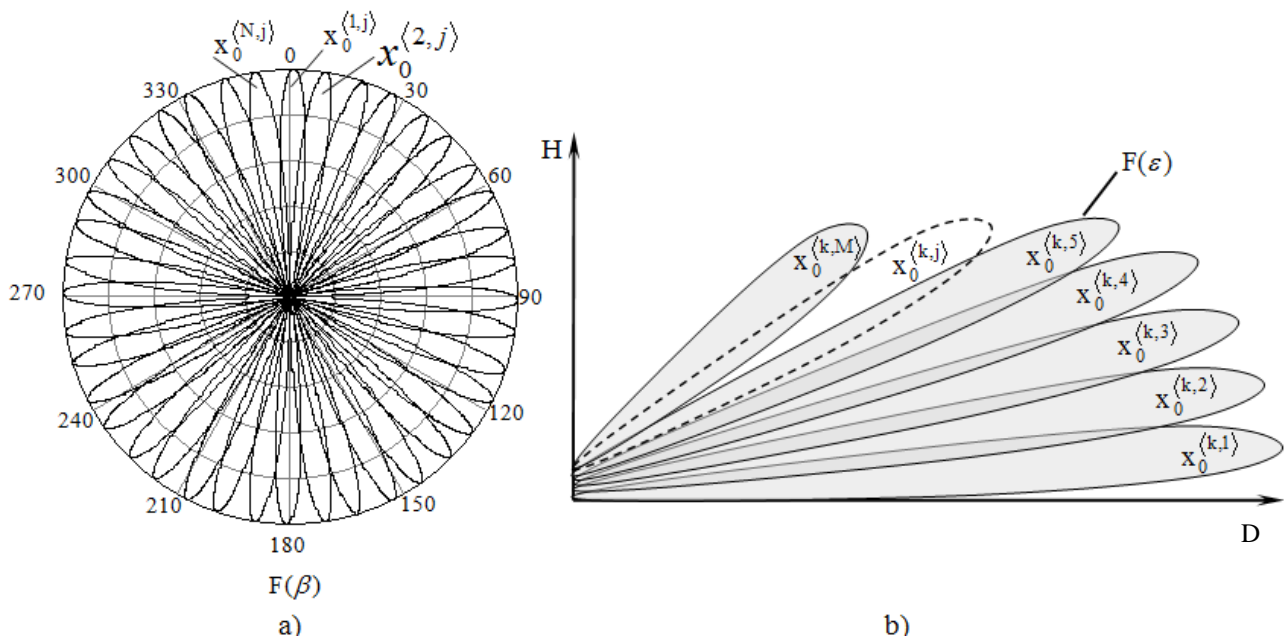

Fig. 19. The directional pattern of the cylindrical phased array antenna a) in the azimuth plane; b) in the elevation plane

Fig. 19 a) shows the antenna directional pattern (ADP) $F(\beta)$ in the azimuth plane (β) and fig. 19 b) shows the ADP $F(\varepsilon)$ in the elevation plane (ε), where a chaotic signal with its $x_0^{(k,l)}$ is emitted in corresponding directions. This approach enables implementing simultaneous multichannel scanning of space.

Thus, the above analysis enables synthesizing a multiradar information-measuring system (MIMS) (fig. 20).

MIMS consists of RS MIMO positions that generate chaotic signals with various initial values $x_0, y_0, z_0, \xi_0, s_0$. This enables developing the necessary number of measuring and information channels. The RS MIMO creates detection areas by multi-channel space scanning (fig. 20). The radar information received from radar positions is fed to the server through wireless channels of communication using data transmitting equipment at a set

of chaotic carriers $x_0^k, y_0^k, z_0^k, \xi_0^k, s_0^k$. The radar information is processed with the help of the server which is a part of a more global information network. Users can obtain information using both wireless and wire communication channel.

Conclusions

Thus, the above properties of chaotic signals enable applying them to build data transmissions systems on the MIMO principle and multichannel radars. This enables building a multiradar information measuring system based on chaotic signals. The above techniques can be implemented to build a network of unattended radars, can be used in multichannel communication systems and to control air traffic, can be used in the air defence net-centered systems to create the common covert information and telecommunication space.

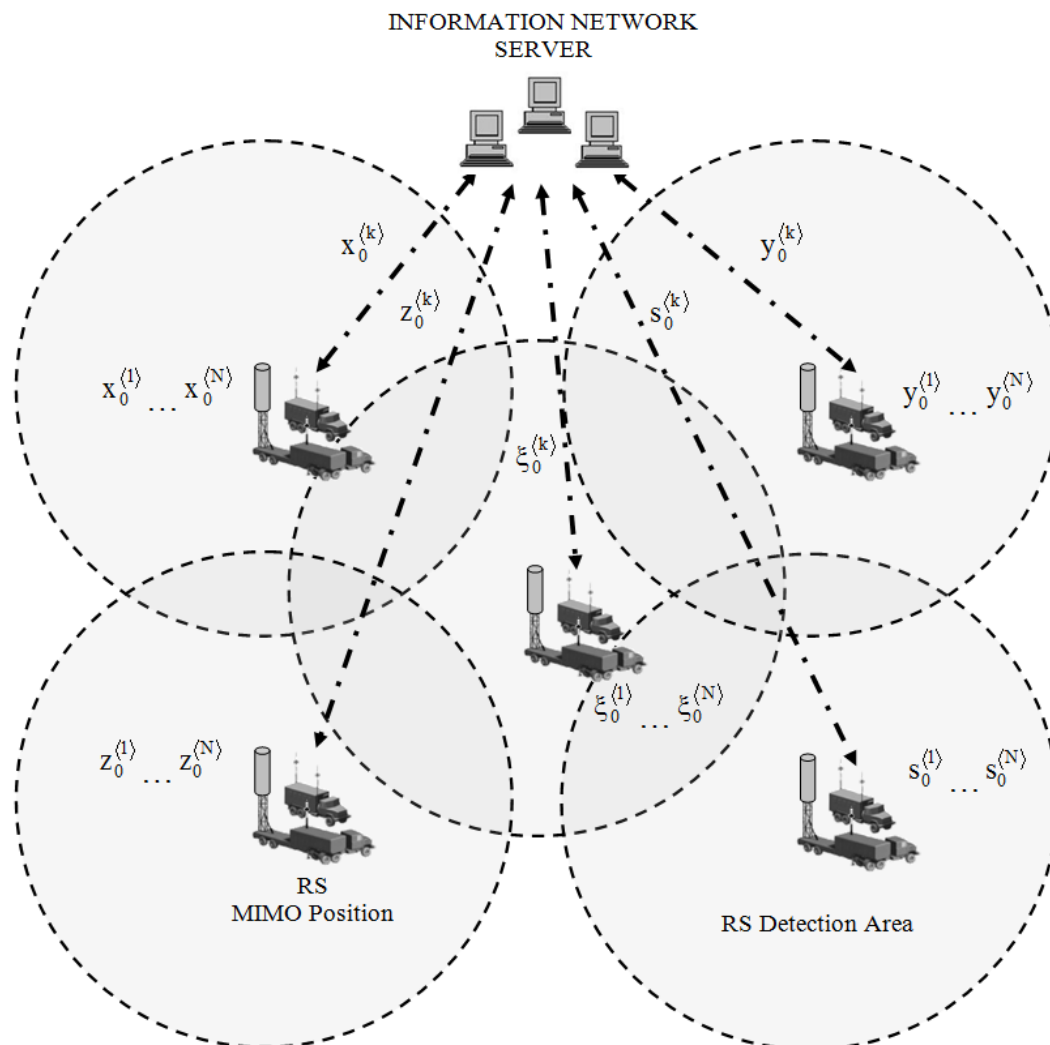

Fig. 20. Multiradar information measuring network (a variant of deployment)

References

1. Kotov, O. B., Pyevtsov, H. V. (2012), "Pohlyady shchodo pobudovy maybutn'oyi systemy protypovitryanoyi oborony krajiny na osnovi merezhetsentrychnykh tekhnolohiy", *Nauka i tekhnika Povitryanykh Syl Zbroynykh Syl Ukrainy*, No. 2 (8), P. 7–14.
2. Pace, P. E. (2009), *Detecting and Classifying Low Probability of Intercept Radar* : Second Edition, London : Artech house, 862 p.
3. Li, H., Wang, F., Chen, J., Zhou, J. (2015), "An effective evaluation metric of LPI radar waveform", *Information Technology: Proceedings of the 2014 International Symposium on Information Technology (ISIT 2014)*, Dalian, China, 14-16 October 2014, P. 125.
4. Kostenko, P. Yu, Vasyuta, K. S., Barsukov, A. N. (2010), "Ispol'zovaniye BDS-statistiki dlya otsenki skrytnosti signala, poluchennogo peremeshivaniyem khaoticheskoy nesushchey", *Izvestiya vuzov. Radioelektronika*, No. 5 (53), P. 41-45.
5. Amin, Salih M. and Potrus, M. Y. (2015), "A Method for Compensation of Tcp Throughput Degrading During Movement Of Mobile Node", *ZANCO Journal of Pure and Applied Sciences*, Vol. 27, No. 6, P. 59–68.
6. Davydovskyi, Yu., Reva, O., Artiukh, O., Kosenko, V. (2019), "Simulation of computer network load parameters over a given period of time", *Innovative Technologies and Scientific Solutions for Industries*, No. 3 (9), P. 72–80. DOI: <https://doi.org/10.30837/2522-9818.2019.9.072>
7. Kosenko, V. (2017), "Mathematical model of optimal distribution of applied problems of safety-critical systems over the nodes of the information and telecommunication network", *Advanced Information Systems*, Vol. 1, No. 2, P. 4–9. DOI: <http://doi.org/10.20998/2522-9052.2017.2.01>
8. Davydovsky, Yu., Reva, O., Maleeva, O. (2018), "Method of modelling the parameters of data communication network for its upgrading", *Innovative Technologies and Scientific Solutions for Industries*, No. 4 (6), P. 15–22. DOI: <http://dx.doi.org/10.30837/2522-9818.2018.6.015>
9. Kuchuk, G., Kovalenko, A., Kharchenko, V., Shamraev, A. (2017), "Resource-oriented approaches to implementation of traffic control technologies in safety-critical I&C systems", *Green IT Engineering: Components Network and Systems Implementation*, Springer International Publishing, Vol. 105, P. 313–338.
10. Lemeshko, O., Yevdokymenko, M., Yeremenko, O. (2019), "Model of data traffic qos fast rerouting in infocommunication networks", *Innovative Technologies and Scientific Solutions for Industries*, No. 3 (9), P. 127–134. DOI: <http://dx.doi.org/10.30837/2522-9818.2019.9.127>

11. Kuchuk, H. A., Mozhayev, O. O., Vorobyov, O. V. (2006), "Metod ahrehuvannya fraktal'noho trafika", *Radioelektronni ta komp'yuterni systemy*, No. 6 (18), P. 181–188.
12. Kuchuk, G. A. (2004), "Fraktal'nyy gaussovskiy shum v trafikovykh trassakh", *Sistemi obrobki informatsii*, No. 3 (31). P. 91–100.
13. Ruban, I., Kuchuk, H., Kovalenko, A. (2017), "Redistribution of base stations load in mobile communication networks", *Innovative Technologies and Scientific Solutions for Industries*, No. 1 (1), P. 75–81. DOI : <https://doi.org/10.30837/2522-9818.2017.1.075>
14. Svyrydov, A., Kuchuk, H., Tsiapa, O. (2018), "Improving efficiency of image recognition process: Approach and case study", *Proceedings of 2018 IEEE 9th International Conference on Dependable Systems, Services and Technologies, DESSERT 2018*, P. 593–597, DOI: <http://dx.doi.org/10.1109/DESSERT.2018.8409201>
15. Kuchuk, G., Kovalenko, A., Komari, I. E., Svyrydov, A., Kharchenko, V. (2019), "Improving big data centers energy efficiency: Traffic based model and method", *Studies in Systems, Decision and Control*, Vol. 171. Springer Nature Switzerland AG, P. 161–183. DOI: http://doi.org/10.1007/978-3-030-00253-4_8
16. Kuchuk, H. A. (2007), "Upravlinnya trafikom mul'tyservisnoyi rozpodilenoyi telekomunikatsiynoyi merezhi", *Systemy upravlinnya, navihatsiyyi ta zv'yazku*, Kyiv : TSNDI NiU, Vol. 2, P. 18–27.
17. Svyrydov, A. C., Kovalenko, A. A., Kuchuk, H. A. (2018), "Metod pererозpodilu propusknoyi zdatnosti krytychnoyi dilyanky merezhi na osnovi udoskonalennya ON/OFF-modeli trafiku", *Suchasni informatsiyni systemy*, Vol. 2, No. 2, P. 139–144. DOI: <https://doi.org/10.20998/2522-9052.2018.2.24>
18. Kovalenko, A. A., Kuchuk, H. A. (2018), "Metody syntezy informatsiynoyi ta tekhnichnoyi struktur systemy upravlinnya ob'yektom krytychnoho zastosuvannya", *Suchasni informatsiyni systemy*, Vol. 2, No. 1, P. 22–27. DOI: <https://doi.org/10.20998/2522-9052.2018.1.04>
19. Kostenko, P. Yu., Vasyuta, K. S., Barsukov, A. N. (2010), "Ispol'zovaniye BDS-statistiki dlya otsenki skrytnosti signala, poluchennogo peremeshivaniyem khaoticheskoy nesushchey", *Izvestiya vuzov. Radioelektronika*, No. 5 (53), P. 41–45.
20. Umnov, A. E. *Analitychna heometriya ta lineyna alhebra*, available at : <http://mat.net.ua>
21. Vasyuta, K. S., Zakharchenko, I. V. (2017), "Method of Message Coding, Using Orthogonal Chaotic Signals in Secure Information Telecommunication Networks", *Fouth International Scientific-Practical Conference ["Problems of Infocommunications. Science and Technology, PICS&T'2017"]*, (Kharkiv, Ukraine, October 3-6, 2017), Kharkiv, P. 274–277.
22. Akintunde, M. O., Oyekunle, J. O., Olalude, G. A. (2015), "Detection of Non-Linearity in the Time Series Using BDS Test", *Science Journal of Applied Mathematics and Statistics*, Vol. 3, No. 4, P. 184–187. DOI: <http://doi.org/10.11648/j.sjams.20150304.13>
23. Vasyuta, K., Zakharchenko, I. (2016), "Evaluation of the potential possibility of organizing multi-channel in chaotic information transmission systems", *Weapons systems and military equipment*, Vol. 2 (46), P. 70–73.
24. Vasyuta, K. S., Ozerov, S. V., Malyshev, A. A. (2013), "Povysheniye skrytnosti peredachi binarnogo soobshcheniya v pryamokhaoticheskoy sisteme radiosvyazi za schet fil'tratsii khaoticheskoy nesushchey", *Zbirnyk naukovykh prats' Kharkivs'koho universytetu Povitryanykh Syl*, Kharkiv : KHUPS, No. 2 (35), P. 78–81.
25. Vasyuta, K. S., Ozerov, S. V., Zots, F. F. (2012), "Hlu-shchenko N.A. Metod povysheniya propusknoy sposobnosti i skrytnosti systemy radiosvyazi putem primeneniya MIMO-tekhnologii na khaoticheskikh nesushchikh", *Sistemi upravlinnya, navigatsii i zv'yazku*, Kyiv : "DP" TSNDI N i U, No. 3 (23), P. 223–227.
26. Chernyak, V. S. (2009), "O novom napravlenii v radiolokatsii: MIMO RLS", *Prikladnaya radioelektronika*, Vol. 8, No. 4, P. 477–489.
27. Li, J., Stoica, P. (2008), *MIMO Radar Signal Processing*, Wiley-IEEE Press, 448 p.
28. Vasyuta, K. S., Zots, F. F., Kovalevs'ky, S. N. (2013), "MIMO RLS, osnovannaya na primenenii ortogonal'nykh khaoticheskikh signalov v setetsentricheskoy sisteme PVO", *Sistemi obrobki informatsii*, Kharkiv : KHUPS, No. 1(108), P. 21–24.

Received 20.11.2019

Відомості про авторів / Сведения об авторах / About the Authors

Васюта Костянтин Станіславович – доктор технічних наук, професор, заслужений діяч науки і техніки України, Харківський національний університет Повітряних Сил імені Івана Кожедуба, заступник начальника з навчальної роботи, Харків, Україна; email: ko-hafish@ukr.net; ORCID: <http://orcid.org/0000-0002-1978-3717>.

Васюта Константин Станиславович – доктор технических наук, профессор, заслуженный деятель науки и техники Украины, Харьковский национальный университет Воздушных Сил имени Ивана Кожедуба, заместитель начальника по учебной работе, Харьков, Украина.

Vasyuta Kostantiv – Doctor of Sciences (Engineering), Professor, Honoured Worker of Science and Technology of Ukraine, Ivan Kozhedub Kharkiv National Air Force University, Deputy Head for Academic Affairs, Kharkiv, Ukraine.

Зоц Федір Федорович – кандидат технічних наук, Харківський національний університет Повітряних Сил імені Івана Кожедуба, старший викладач кафедри озброєння радіотехнічних військ, Харків, Україна; email: fedorzots@gmail.com; ORCID: <http://orcid.org/0000-0001-6070-2862>.

Зоц Федор Федорович – кандидат технических наук, Харьковский национальный университет Воздушных Сил имени Ивана Кожедуба, старший преподаватель кафедры вооружения радиотехнических войск, Харьков, Украина.

Zots Fedor – PhD (Engineering Sciences), Ivan Kozhedub Kharkiv National Air Force University, Senior Lecture of the Department of Radar Armament, Kharkiv, Ukraine.

Захарченко Ірина Вікторівна – кандидат технічних наук, Харківський національний університет Повітряних Сил імені Івана Кожедуба, викладач кафедри математичного і програмного забезпечення автоматизованих систем управління, Харків, Україна; email: irishka310379@gmail.com; ORCID: <http://orcid.org/0000-0002-8534-1888>.

Захарченко Ирина Викторовна – кандидат технических наук, Харьковский национальный университет Воздушных Сил имени Ивана Кожедуба, преподаватель кафедры математического и программного обеспечения автоматизированных систем управления, Харьков, Украина.

Zakharchenko Irina – PhD (Engineering Sciences), Ivan Kozhedub Kharkiv National Air Force University, Lecture of the Department of Mathematical and Software of Automated Control Systems, Kharkiv, Ukraine.

КОНЦЕПЦІЯ ПОБУДОВИ ПРИХОВАНОЇ ІНФОРМАЦІЙНО-ВИМІРЮВАЛЬНОЇ СИСТЕМИ ПРОТИПОВІТРЯНОЇ ОБОРОНИ НА ОСНОВІ ЗАСТОСУВАННЯ ОРТОГОНАЛЬНИХ ХАОТИЧНИХ СИГНАЛІВ

Предметом дослідження в статті є прихована інформаційно-вимірювальна система, заснована на ортогональних хаотичних сигналах. **Мета** роботи – синтезувати приховану інформаційно-вимірювальну систему, побудовану на основі ортогональних хаотичних сигналів. **Завдання**, вирішені в ході дослідження, – оцінено потенційні можливості організації багатоканальності з використанням хаотичних несучих; вивчені способи застосування хаотичних сигналів в бездротових системах передачі даних; синтезована загальна структура радіолокаційної системи МІМО на основі ортогональності хаотичних сигналів. При проведенні досліджень було використано загальнонаукові та спеціальні **методи** дослідження, зокрема, системний аналіз і математичне моделювання. Були отримані такі **результати**: запропоновано концепцію побудови мережецетричної багаторадарної інформаційно-вимірювальної системи (MIMS). Показано, що застосування ортогональних хаотичних сигналів для виявлення повітряних цілей та передачі інформації про них, підвищує перешкодозахищеність, роздільну і пропускну здатність; дозволяє забезпечити електромагнітну сумісність і поділ каналів виявлення й передачі інформації. Синтезовано структурну схему MIMS. **Висновки**. Специфічні властивості хаотичних сигналів дозволяють застосовувати їх для побудови систем передачі даних за принципом МІМО та багатоканальних радарів. На основі хаотичних сигналів може бути побудовано багаторадарну систему вимірювання інформації. Вищевказані методи можуть бути реалізовані для побудови мережі необслуговуваних радарів, а також в багатоканальних системах зв'язку. Вони можуть застосовуватися для управління повітряним рухом і можуть використовуватися в системах, орієнтованих на мережу ППО для створення загального прихованого інформаційного і телекомунікаційного простору.

Ключові слова: хаотичні сигнали; сигнально-кодові конструкції; МІМО-технологія; інформаційно-вимірювальна система.

КОНЦЕПЦІЯ ПОСТРОЕНИЯ СКРЫТОЙ ИНФОРМАЦИОННО-ИЗМЕРИТЕЛЬНОЙ СИСТЕМЫ ПРОТИВОВОЗДУШНОЙ ОБОРОНЫ НА ОСНОВЕ ПРИМЕНЕНИЯ ОРТОГОНАЛЬНЫХ ХАОТИЧЕСКИХ СИГНАЛОВ

Предметом исследования в статье является скрытая информационно-измерительная система, основанная на ортогональных хаотических сигналах. **Цель** работы – синтезировать скрытую информационно-измерительную систему, построенную на основе ортогональных хаотических сигналов. **Задачи**, решенные в ходе исследования, – оценены потенциальные возможности организации многоканальности с использованием хаотических несущих; изучены способы применения хаотических сигналов в беспроводных системах передачи данных; синтезирована общая структура радиолокационной системы МІМО на основе ортогональности хаотических сигналов. При проведении исследований использовались общенаучные и специальные **методы** исследования, в частности, системный анализ и математическое моделирование. Были получены следующие **результаты** предложена концепция построения сетецетрической мультирадарной информационно-измерительной системы (MIMS). Показано, что применение ортогональных хаотических сигналов для обнаружения воздушных целей и передачи информации о них, повышает помехозащищенность, разрешающую и пропускную способность; позволяет обеспечить электромагнитную совместимость и разделение каналов обнаружения и передачи информации. Синтезирована структурная схема MIMS. **Выводы**. Специфические свойства хаотических сигналов позволяют применять их для построения систем передачи данных по принципу МІМО и многоканальных радаров. На основе хаотических сигналов может быть построена мультирадарная система измерения информации. Вышеуказанные методы могут быть реализованы для построения сети необслуживаемых радаров, а также в многоканальных системах связи. Они могут применяться для управления воздушным движением и могут использоваться в системах, ориентированных на сеть ПВО для создания общего скрытого информационного и телекоммуникационного пространства.

Ключевые слова: хаотические сигналы; сигнально-кодовые конструкции; МІМО-технология; информационно-измерительная система.

Бібліографічні описи / Bibliographic descriptions

Васюта К. С., Зоц Ф. Ф., Захарченко І. В. Концепція побудови прихованої інформаційно-вимірювальної системи протиповітряної оборони на основі застосування ортогональних хаотичних сигналів. *Сучасний стан наукових досліджень та технологій в промисловості*. 2019. № 4 (10). С. 33–43. DOI: <https://doi.org/10.30837/2522-9818.2019.10.033>.

Vasyuta, K., Zots, F., Zakharchenko, I. (2019), "Building the air defense covert information and measuring system based on orthogonal chaotic signals", *Innovative Technologies and Scientific Solutions for Industries*, No. 4 (10), P. 33–43. DOI: <https://doi.org/10.30837/2522-9818.2019.10.033>.