

**Kasabova K.,  
Zagorulko A.,  
Zahorulko A.**

## **DEVELOPMENT OF A METHOD FOR PRODUCING FRUIT BERRY PASTE AND EQUIPMENT FOR ITS IMPLEMENTATION**

Об'єктом дослідження є технологічний процес виробництва плодово-ягідного напівфабрикату. Існуючі технології переробки плодово-ягідної сировини характеризуються втратами коштовних компонентів вихідної сировини, а саме бланшування за температурою 85–100 °С і довготривале уварювання, у результаті чого втрати вітамінів можуть досягати 60 %. Апаратурне оформлення традиційних процесів переробки плодів і овочів, як правило, є недостатньо уніфікованим, незручним в експлуатації та розраховане на високу продуктивність. Одним з найбільш проблемних місць є значні енерго- та металовитрати традиційного обладнання та недостатньо висока якість готового продукту. Інтенсифікація процесів переробки плодово-ягідної сировини можлива шляхом впровадження нових технологій та обладнання, використання якого дозволяє зменшити витрати енергетичних і матеріальних ресурсів.

В ході дослідження використовувалися експериментальні результати розробленої пасты: яблуко – 60 %; абрикос – 30 %; кизил – 10 % з урахуванням органолептичних та фізико-хімічних показників. Для технологічного процесу виробництва пасты підібрано апаратурну лінію з використанням розробленого універсального багатофункціонального апарату (УБА) та роторного плівкового апарату (РПА). Це забезпечить гарантоване підвищення техніко-експлуатаційних показників з значним зниженням енерго- та металовитрат в порівнянні з існуючими аналогами. Встановлено, що для ефективного випарювання пюре в РПА від 11–14 % до 27–30 % сухих речовин необхідно після розварювання в УБА перетирати сировину до діаметру часток не більше 0,1–0,5 мм. Температура обробки пюре у РПА складає 62–67 °С, а тривалість концентрування 2–3 хв. Для скорочення терміну випарювання та більш раціонального використання РПА треба перед цією операцією застосовувати підігрівання пюре до 55–60 °С.

Впровадження розробленої апаратурно-технологічної лінії сприятиме виробництву конкурентоспроможного напівфабрикату підвищеної якості з широким спектром використання у харчових виробництвах та ресторанних господарствах.

**Ключові слова:** плодово-ягідна паста, технологічна лінія, концентрування пюре, універсальний багатофункціональний апарат, роторний плівковий апарат.

Received date: 15.01.2020

Accepted date: 21.02.2020

Published date: 30.04.2020

Copyright © 2020, Kasabova K., Zagorulko A., Zahorulko A.

This is an open access article under the CC BY license

(<http://creativecommons.org/licenses/by/4.0>)

### **1. Introduction**

Deficiency of fruit and berry raw materials is the most common nutritional problem, which leads to serious negative consequences [1]. Immunodeficiency, infectious diseases, the manifestation of negative heredity can be prevented or significantly weakened, if understand the role of vitamin-containing factors, biologically active substances in general, macro- and microelements in human nutrition when they adapt to their real environment. The increased load on a modern person dictates the need to constantly maintain at the required level of functioning mechanisms of long-term that is perfect adaptation, which implies the following important condition for directed influence on these systems: nutrition should be balanced and aimed at many metabolic links and body defense mechanisms [2, 3]. This effect is exerted by many components of food products, primarily vegetable, in a concentrated state. These are vitamins and minerals, especially their combinations, since

it is combinations of these substances that are physiological health factors [4]. A special place among concentrated semi-finished products is occupied by fruit pastes with unconventional raw materials – natural vitamins with various therapeutic and prophylactic properties, contribute to the formation of structure and improve the color of food [5, 6]. Their wider use in the manufacture of various food products is constrained by the lack of information about their chemical composition, technological properties, as well as the lack of technologies and equipment for their production [7, 8]. Therefore, it is relevant to develop a method for processing fruit and berry raw materials and their hardware design for the production of pasta of high biological value and the required quality. Thus, *the object of research* is the technological process for the production of fruit and berry semi-finished product. *The aim of research* is to develop advanced high-performance technology and equipment for processing fruit and berry raw materials into fruit pastes.

## 2. Methods of research

During the development of a method for the production of fruit paste, ripe raw materials (apple, apricot, cornel) were freshly collected, which were prepared according to the developed technological scheme. To substantiate the recipe for the obtained paste, 3 samples of prototypes were prepared with different formulation ratios of the components and then mixed into a homogeneous puree mass. During the research, the content of components in the multicomponent composition changed: for apples – 55–65 g of apricot – 25–35 g and cornel – 5–15 g, respectively. Analysis of the prototypes by structural-mechanical, physico-chemical and organoleptic indicators allowed to choose the optimal composition with the content of: apple – 60 %; apricot – 30 %; cornel – 10 %. For static probability, all experiments in the laboratory were performed in five repetitions. To obtain the regime parameters of blanching and concentration, classical methods for studying heat transfer processes were used.

## 3. Research results and discussion

In the manufacture of fruit pastes, in many cases, they use apple cultivars containing a large amount of pectin substances (up to 1.5 %), carbohydrates, mainly fructose. However, apples have relatively few vitamins, organic acids, and the color scheme of apple food products is rather poor and aesthetically unfavorable. It is these shortcomings that can be eliminated by blending apples with different plant materials. Using a variety of fruit and berry raw materials will make it possible to enrich the resulting pastes with biologically active substances, in particular vitamins, polyphenols, pectins, tannins, expand their aromatic and flavoring gamut, and improve their appearance.

Blended fruit and berry pastes are characterized by a diverse number of components, in particular, let's propose to consider an apple-based composition with the addition of apricot and cornel in the ratio: apple – 60 %; apricot – 30 %; cornel – 10 %. This component composition was created taking into account the organoleptic and physico-chemical parameters of the raw materials and ensuring

the resulting active acidity of the pH of the pastes at the level of 3.3–3.5.

The proposed production of pasta is proposed to be carried out in an improved way on a pre-selected hardware-technological complex (Fig. 1). The primary site for the preparation of raw materials for the production of multi-component fruit paste consists of inspection, washing, preliminary heat treatment and wiping in conditions of successive receipt of processed raw materials. The most lengthy operation is the preliminary heat treatment of raw materials for the implementation of which a universal multi-functional device (UMD) was previously developed [9], which allows the main heat and mass transfer processes to be carried out: holding, drying, blanching, boiling, cooking, infusing, mixing, dissolving and partially extracting.

The expediency of using UMD in the line is due to the specific features of fruit and berry raw materials, which in addition to high nutritional and biological value have certain negative properties – hard peel, excessive bitterness and astringency of taste, acidity. It is to reduce the influence of the properties of the raw material, it is additionally blanched in a 1–2 % solution of citric acid at a temperature of 55–65 °C for 3–4 minutes to stabilize the polyphenolic complex and soften tissues.

Apricot and cornel are wiped, separating the peels and seeds on a double wiping machine with sieve diameters: 1.2–1.5 and 0.5–0.8 mm. Obtained after rubbing the peel and bones with the remains of the pulp are boiled for 5–8 minutes. The ratio of the mass of the skin and seeds to pulp to the mass of water is 1:0.5–1:0.7. The resulting mass is wiped on a double wiping machine to increase the yield of finished products and obtain low-waste (resource-efficient) technology. Applesauce is prepared according to the current technological instructions for the production of fruit and berry purees. Then carry out the mixing while stirring the applesauce with mashed masses (apricot, cornel) and mashed mass of decoction from the peel and seeds of these berries. The obtained multicomponent mass is fed into a rotary-pulsation device to destroy the intercellular structure, and therefore the release of all nutrient cellular substances with a partial additional heating of the fruit mass due to viscous friction.

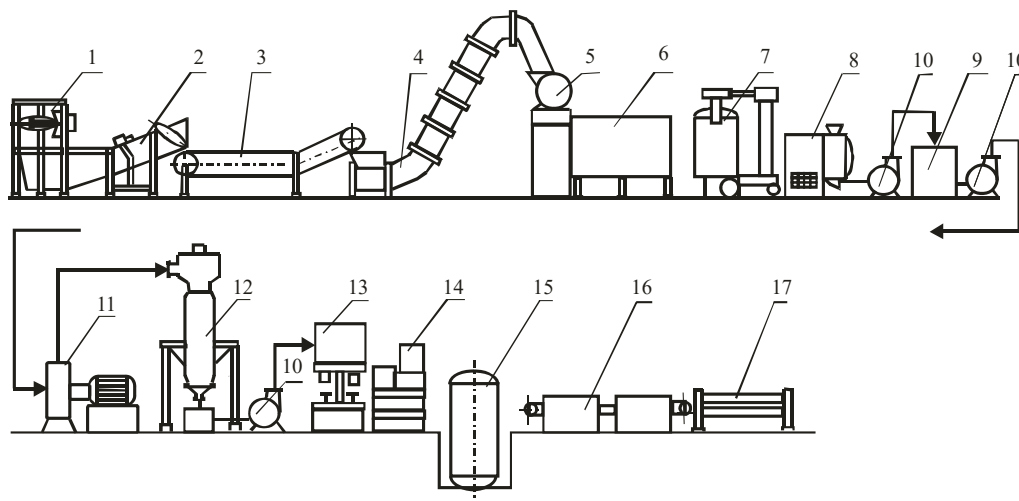

**Fig. 1.** Technological scheme for the production of fruit paste:

1 – container transfer; 2 – washing machine; 3 – inspection roller conveyor; 4 – elevator; 5 – crusher; 6 – capacity for the accumulation of liners; 7 – universal multifunctional device; 8 – cleaning machine; 9 – collection measuring devices; 10 – gear pump; 11 – rotary pulsation device; 12 – rotary film device; 13 – filler; 14 – seaming machine; 15 – autoclave; 16 – washer-dryer; 17 – labeling machine

Next, the obtained finely divided puree mixture (particle diameter of not more than 0.1–0.5 mm) is immediately fed for boiling to an improved rotary film device (RFD) [10]. Puree boiling from 11–14 % to 27–30 % dry matter at a temperature of 62–67 °C pressure of 1.3–2.7 kPa occurs within 2–3 minutes. To reduce the time of evaporation and more efficient use of RFD, before this operation, it is necessary to apply puree to 55–60 °C. After that, the resulting mass is packaged at a temperature of 85–90 °C, cork, sterilize, and mark. The use of low temperatures during boiling (62–67 °C) prevents significant losses of biologically valuable substances. An increase in viscosity is noted in comparison with the control (apple paste CP 30 % 124 Pa·s), research paste 274 Pa·s, as well as an improvement in organoleptic characteristics.

#### 4. Conclusions

A technological equipment line has been developed for the production of fruit pastes with significant preservation of the initial properties of raw materials through the use of highly efficient heating equipment. The developed fruit paste can be used as a vitamin supplement, filler, thickener in various sectors of the food industry, such as confectionery, dairy, bakery, as well as for cooking and drinks at food establishments and at home.

#### References

1. Del Río-Celestino, M., Font, R. (2020). The Health Benefits of Fruits and Vegetables. *Foods*, 9 (3), 369. doi:10.3390/foods9030369
2. Bogatyrev, A. N., Prianichnikova, N. S., Makeeva, I. A. (2017). Naturalnye produkty pitaniia – zdorove natsii. *Pishchevaia promyshlennost*, 8, 26–29. Available at: <https://cyberleninka.ru/article/n/naturalnye-produkty-pitaniya-zdorovie-natsii>
3. Percival, S. S. (2011). Nutrition and Immunity. *Nutrition Today*, 46 (1), 12–17. doi: <http://doi.org/10.1097/nt.0b013e3182076fc8>
4. Golubtsova, Y. V., Prosekov, A. Y., Moskvina, N. A. (2019). Identification of fruits and berries raw materials in multi-component food systems. *Dairy Industry*, 3, 28–29. doi: <http://doi.org/10.31515/1019-8946-2019-3-28-29>
5. Kupin, G. A., Pershakova, T. V., Gorlov, S. M., Viktorova, E. P., Matvienko, A. N., Velikanova, E. V. (2017). Issledovanie vliianiia obrabotki fruktov elektromagnitnymi poliami kraine nizkikh chastot i biopreparatami na poteri biologicheskii aktivnykh veshchestv v protsesse khraneniia. *Politematicheskii setevoi elektronnyi nauchnyi zhurnal Kubanskogo gosudarstvennogo agrarnogo universiteta*, 132, 1111–1121.
6. Cherevko, O. I., Yefremov, Yu. I., Mykhailov, V. M. (2007). *Pererobka dykorosloi priano-aromatichnoi roslynnoi syrovyny*. Kharkiv: KhDUKhT, 230.
7. Gaiazova, A. O., Prokhasko, L. S., Popova, M. A., Lukinykh, S. V., Asenova, B. K. (2014). Ispolzovanie vtorichnogo i rastitel'nogo syria v produktakh funktsionalnogo naznacheniia. *Molodoi uchenyi*, 19, 189–191.
8. Derevitskaia, O. K., Dydykin, A. S., Ustinova, A. V., Aslanova, M. A. (2016). Novye standarty na konservy dlia detskogo pitaniia. *Pishchevaia promyshlennost*, 1, 22–25.
9. Zagorulko, A., Zahorulko, A., Kasabova, K., Chervonyi, V., Omelchenko, O., Sabadash, S. et. al. (2018). Universal multifunctional device for heat and mass exchange processes during organic raw material processing. *Eastern-European Journal of Enterprise Technologies*, 6 (1 (96)), 47–54. doi: <http://doi.org/10.15587/1729-4061.2018.148443>
10. Cherevko, O., Mykhaylov, V., Zagorulko, A., Zahorulko, A. (2018). Improvement of a rotor film device for the production of highquality multicomponent natural pastes. *Eastern-European Journal of Enterprise Technologies*, 2 (11 (92)), 11–17. doi: <http://doi.org/10.15587/1729-4061.2018.126400>

**Kasabova Kateryna**, PhD, Associate Professor, Department of Technology of Bakery, Confectionary, Pasta and Food Concentrates, Kharkiv State University of Food Technology and Trade, Ukraine, ORCID: <http://orcid.org/0000-0001-5827-1768>, e-mail: [Kasabova\\_kateryna@hduht.edu.ua](mailto:Kasabova_kateryna@hduht.edu.ua)

**Zagorulko Aleksey**, PhD, Associate Professor, Department of Processes, Devices and Automation of Food Production, Kharkiv State University of Food Technology and Trade, Ukraine, ORCID: <http://orcid.org/0000-0003-1186-3832>, e-mail: [zagorulko@hduht.edu.ua](mailto:zagorulko@hduht.edu.ua)

**Zahorulko Andreii**, PhD, Associate Professor, Department of Processes, Devices and Automation of Food Production, Kharkiv State University of Food Technology and Trade, Ukraine, ORCID: <http://orcid.org/0000-0001-7768-6571>, e-mail: [zagorulkoAN@hduht.edu.ua](mailto:zagorulkoAN@hduht.edu.ua)