



Kalchenko V.,  
Kalchenko V.,  
Sira N.,  
Kuzhelnyi Y.,  
Vynnyk V.

## RESEARCH OF THE MILLING PROCESS OF A CYLINDRICAL SURFACE BY AN ORIENTED INSTRUMENT

Об'єктом дослідження є процес фрезерування зі схрещеними осями циліндричної поверхні та інструмента. Під час проведення досліджень були застосовані загальні модульні тривимірні моделі інструментальної поверхні, процесів зняття припуску та формоутворення циліндричної поверхні на базі трьох уніфікованих модулів: інструментального, формоутворення та орієнтації. Також використовувалось комп'ютерне моделювання для побудови тривимірної моделі процесу фрезерування циліндричної поверхні орієнтованим інструментом. Створена графічна схема фрезерування циліндричної поверхні орієнтованим інструментом. Розроблені циліндричний модуль формоутворення поверхні інструменту, який описується добутком матриць переміщень вздовж відповідних осей, та поверхня обробленої деталі, представлена добутком радіуса вектора інструмента та модуля її орієнтації в системі координат вала. Отримано графік розподілу питомої продуктивності процесу фрезерування вздовж профілю зуба інструмента при обробці зі схрещеними осями фрези та деталі. Аналіз вказаного графіка показав, що спосіб фрезерування орієнтованим інструментом дає можливість підвищити точність процесу формоутворення за рахунок рівномірного зносу інструмента. Також було визначено кут схрещення циліндричної поверхні та інструмента, величина якого приймається із умови забезпечення максимального зняття шару матеріалу при рівномірному завантаженні торцевої частини фрези. Для цього розроблено тривимірну модель процесу фрезерування циліндричної поверхні зі схрещеними осями інструменту та деталі, при якому чорнове фрезерування здійснюється торцевою частиною інструмента, а чистове – периферійною. В ході проведених досліджень визначено, що при чистовому фрезеруванні величина кута повороту фрези приймається із умови забезпечення повного завантаження периферійної частини фрези. Підвищення ефективності обробки досягається за рахунок схрещення осей інструмента та деталі, що дає можливість програмувати точку схрещення, та рівномірного зносу фрези, що підвищує якість обробленої поверхні. Також для забезпечення підвищення продуктивності обробки можливе застосування високошвидкісного фрезерування.

**Ключові слова:** фрезерування зі схрещеними осями, орієнтована фреза, модульне тривимірне моделювання, кут схрещення, циліндрична деталь.

Received date: 24.01.2020

Accepted date: 28.02.2020

Published date: 30.06.2020

Copyright © 2020, Kalchenko V., Kalchenko V., Sira N., Kuzhelnyi Y., Vynnyk V.

This is an open access article under the CC BY license

(<http://creativecommons.org/licenses/by/4.0>)

### 1. Introduction

One of the most common parts that are produced by engineering enterprises includes parts that have cylindrical surfaces of revolution. In order for the parts to fulfill all the technical conditions, their critical surfaces must satisfy the necessary requirements for quality and accuracy. Milling is a productive method for processing cylindrical parts. The study of the milling process of the cylindrical surface makes it possible to increase the processing productivity while maintaining the necessary quality and accuracy of the surfaces of the parts. So, in [1], the results of a study of milling parts with cylindrical surfaces using a set of disk milling cutters are presented. And in [2], a method for milling cylindrical parts that have a large diameter is considered. In this method, two end mills are used, the axes of which are crossed with the axis of the part and a longitudinal feed of the tool is carried out along the axis of the part. A study of the milling process with the crossed axes of cylindrical parts and tools was carried out in [3]. In addition, the work [4, 5] was devoted to

the study of the milling process of cylindrical surfaces. In [6, 7], three-dimensional models of various methods of milling materials were studied. Thus, the study of the milling of a cylindrical surface with an oriented tool is an urgent task. Thus, *the object of research* is the milling process with the crossed axes of the cylindrical surface and the tool. *The aim of research* is to develop a three-dimensional model of the process of milling a cylindrical surface with the end and the periphery of the cutter with crossed axes of the tool and part.

### 2. Methods of research

During the research, the results of [8, 9] are applied.

Fig. 1 shows a diagram of a milling process with crossed axes of a mill 1 and a shaft 2.

To obtain a three-dimensional tool surface, it is necessary to define a cylindrical shaping module that takes into account changes in the position of the coordinate along the profile of the tool tooth and the rotation angle  $\varphi$  of the tool:

$$\bar{R}_t = M_{Z_t, \alpha_t, R_t}^C \cdot \bar{e}_4, \tag{1}$$

where  $\bar{R}_t$  – radius vector of the tool points;  $M_{Z_t, \alpha_t, R_t}^C$  – cylindrical tool shaping module;  $\bar{e}_4$  – radius vector of the initial coordinate [8].

The cylindrical tool surface shaping module is described as the product of the displacement matrices M2, M3 along the  $Y_t$  ra  $Z_t$  axes of the M6 rotation matrix around the  $O_t Z_t$  axis:

$$M_{Z_t, \alpha_t, R_t}^C = M3(Z_t) \cdot M6(\alpha_t) \cdot M2(R_t), \tag{2}$$

where  $Z_t = 0 \dots H$  – linear coordinate along the periphery of the tool tooth, varies from 0 to the value of the cutter width H;  $R_t$  – outer tool radius;  $\alpha_t = 0 \dots 360^\circ$  – angular coordinate along the tool profile.

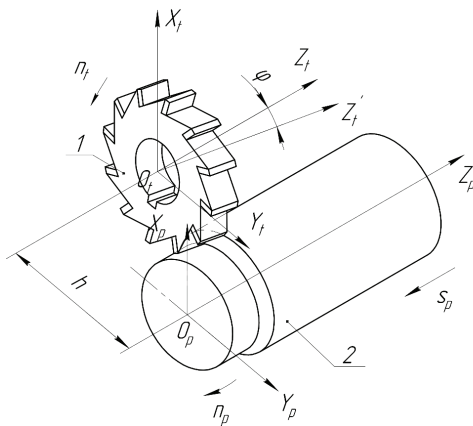

Fig. 1. Scheme of milling a cylindrical surface with an oriented tool:  
1 – mill; 2 – shaft

The product of the radius vector of the tool and its orientation module in the shaft coordinate system, as well as the part shaping module, have a machined part surface:

$$\begin{aligned} \bar{R}_p &= M_{Z_p, \beta_p, h}^C \cdot M_{\alpha, \beta}^S \cdot \bar{R}_t = \\ &= M3(Z_p) \cdot M6(\beta_p) \cdot M2(h) \cdot M4(\varphi) \cdot M5(\psi), \end{aligned} \tag{3}$$

where  $M_{Z_p, \beta_p, h}^C = M3(Z_p) \cdot M6(\beta_p) \cdot M2(h)$  – cylindrical module that describes the movement of the tool relative to the part;  $Z_p$  – part feed along the axis  $O_p Z_p$ ;  $\beta_p$  – rotation angle of the part;  $h$  – center distance of the shaft and tool;  $M_{\alpha, \beta}^S = M4(\varphi) \cdot M5(\psi)$  – spherical module of tool orientation in the coordinate system of the part;  $\varphi$  – intersection angle of the axes of the cutter and the part;  $\psi$  – rotation angle of the tool in the coordinate system of the shaft [8, 9].

Given equations (1) and (2), a cylindrical surface when processing with an oriented tool will look like:

$$\bar{R}_p = M_{Z_p, \beta_p, h}^C \cdot M_{\alpha, \beta}^S \cdot M_{Z_t, \alpha_t, R_t}^C \cdot \bar{e}_4. \tag{4}$$

The contact condition of the cutter profiles and parts at different points in time [3] is used to determine the profile of the machined shaft.

A modular three-dimensional model of the tool  $R_t$  (equation (1)) is used to determine the specific processing productivity  $Q$ :

$$Q = \int_{\alpha_{t1}}^{\alpha_{t2}} Vn \cdot R_t d\alpha, \tag{5}$$

where  $Vn$  – projection of the relative speed vector of the mill on the direction of the normal to its surface;  $\alpha_{t1}, \alpha_{t2}$  – angular coordinates along the profile of the tool.

A graph of the distribution of the specific processing productivity  $Q$  along the profile of the cutter tooth when processing with an oriented tool is shown in Fig. 2.

In the graph (Fig. 2), the section from  $i_{rend}$  to  $i_{rst}$  corresponds to the cutter end, and  $i_{rst}$  starts from the beginning the peripheral part of the tool. So, the removal of the rough allowance falls on the end face of the tooth of the instrument, and the finishing allowance – on the peripheral section. While the specific processing productivity  $Q$  in the direction from  $i_{rend}$  to  $i_{rst}$  decreases, and after that  $i_{rst}$  takes the smallest values. So, the milling process of a cylindrical surface with an oriented tool provides high accuracy of shaping the part surface due to the small wear of the final peripheral parts of the tool tooth.

Therefore, rough milling of a cylindrical surface with an oriented tool is possible to carry out with the end part of the cutter, and the finish is peripheral. This processing method will provide the necessary quality and accuracy of the machined surfaces of the parts.

To ensure the removal of the maximum allowance while maintaining the condition of uniform loading of the end face of the mill during rough processing of the cylindrical surface, the tool is rotated through an angle  $\varphi$  relative to the part:

$$\varphi = 2s_p \sqrt{\frac{(R_p + r_z)^2}{4(r_z + m)^2 \cdot R_p^2 - [2r_z(R_p - m) - m^2]^2}}, \tag{6}$$

where  $m$  – processing allowance [9];  $s_p$  – longitudinal feed of the part;  $r_z$  – radius of the workpiece.

When finishing processing, the cutter 1 must be oriented relative to the workpiece 2 at an angle at which the end point  $i_{rend}$  of the curvature radius  $r$  of the cutter tooth will be placed on the radius of the workpiece  $r_z$  (Fig. 3).

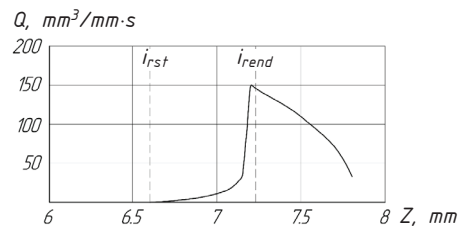

Fig. 2. Distribution of specific processing productivity along the tooth profile of the tool

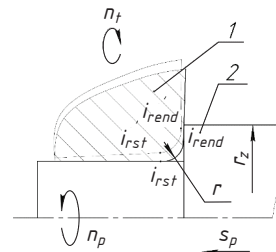

Fig. 3. The scheme for determining the orientation angle of the tool relative to the part: 1 – mill; 2 – workpiece

This placement of the tool will provide the condition for a full load of the peripheral section of the cutter during finishing of parts. This will contribute to an even distribution of forces and wear of the cutter teeth.

### 3. Research results and discussion

Using the results of studies in [10], a three-dimensional model of the process of milling a cylindrical surface 2 (Fig. 4) with an oriented tooth of a mill 1 in the form of a tetrahedral plate is created. The universal software ABAQUS is used to create this model. The finite element mesh is applied using the Mesh module. The shape of the elements is chosen hexahedral.

The resulting stress distribution model makes it possible to analyze the state of the surface layer of the part in the process of milling with an oriented tool. So, according to Fig. 4, the highest stress values (4390 MPa) fall on the insertion zone of the cutting insert into the part, and when approaching the periphery of the tool they decrease (295 MPa).

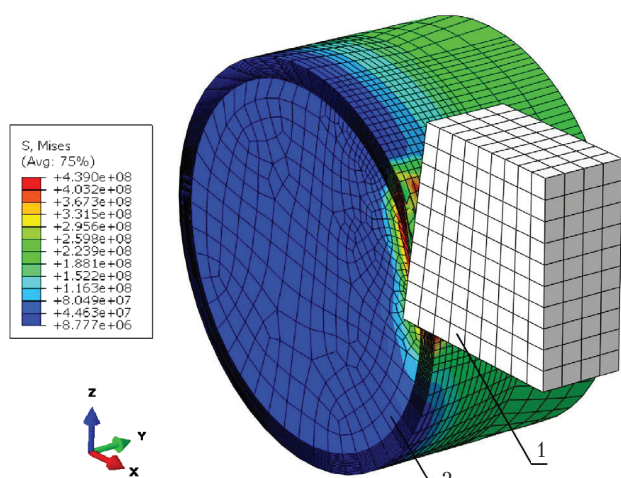

**Fig. 4.** Three-dimensional model of the process of milling a cylindrical surface with an oriented tool: 1 – oriented mill tooth; 2 – processed shaft

When milling a cylindrical surface with crossed tool axes by the end face of the cutter tooth, the rough stock is removed, and the periphery is responsible for removing the final stock and the final shaping of the part surface.

This distribution of the allowance provides an increase in processing productivity and accuracy of shaping due to the uniform minimum wear of the final section of the tool (Fig. 2). The performance of the milling process with an oriented tool is affected by the width of the tool, the number of cutting inserts and their material.

In this case, roughing is carried out with the orientation angle of the cutter (equation (6)), which ensures uniform loading of the tool face and removal of the maximum allowance. A fine milling – with the rotation angle of the tool, which provides the condition for a full load of the periphery of the tool (Fig. 3).

### 4. Conclusions

A three-dimensional milling model has been developed that makes it possible to study the processes of removing allowance and shaping of the part surface. The proposed method improves the processing productivity due to the intersection of the axes of the tool and the part, as well as the shaping accuracy due to the possibility of programming the point of intersection of the axes of the mill and the cylindrical part. Roughing with the end face of the tool, and finishing with its periphery ensure uniform wear of the tool. At the

same time, for effective roughing, the rotation angle of the cutter is taken from the condition of uniform loading and maximum removal of the allowance with the end face of the tool. And during finishing – with a full load of the peripheral part of the cutter. The resulting stress distribution model makes it possible to analyze the state of the surface layer of the part in the process of milling with an oriented tool.

### References

1. Gryazev, M. V., Stepanenko, A. V. (2010). Perspektivnye tekhnologii obrabotki poverhnostey vrashcheniya frezerovaniem. *Izvestiya TulGU. Seriya: Tekhnicheskie nauki*, 2 (1), 130–136. Available at: <https://cyberleninka.ru/article/n/perspektivnye-tehnologii-obrabotki-poverhnostey-vrashcheniya-frezerovaniem>
2. Poletaev, V. A., Volkov, D. I. (2001). Osobennosti struzhko-obrazovaniya pri frezerovanii i frezotochenii tel vrashcheniya. *Inzhenernyi zhurnal*, 7, 18–21.
3. Kalchenko, V., Sira, N., Kalchenko, D., Aksonova, O. (2018). Investigation of the milling cylindrical surfaces process with tool crossed axes. *Technical sciences and technologies*, 4 (14), 18–27. doi: [http://doi.org/10.25140/2411-5363-2018-4\(14\)-18-27](http://doi.org/10.25140/2411-5363-2018-4(14)-18-27)
4. Sliednikova, O., Vynnyk, V., Sklyar, V., Aksonova, O. (2019). Modular 3D modeling of tools, process of adaptation removal and forming at milling the cams with crossing tools and details. *Technical sciences and technologies*, 1 (15), 53–62. doi: [http://doi.org/10.25140/2411-5363-2019-1\(15\)-53-62](http://doi.org/10.25140/2411-5363-2019-1(15)-53-62)
5. Gryazev, M. V., Stepanenko, A. V. (2010). Frezerovanie naruzhnyh cilindricheskikh poverhnostey torcovymi frezami. *Izvestiya TulGU. Seriya Tekhnicheskie nauki*, 2 (1), 140–148. Available at: <https://cyberleninka.ru/article/n/frezerovanie-naruzhnyh-tsilindricheskikh-poverhnostey-torcovymi-frezami>
6. Rubeo, M. A., Schmitz, T. L. (2016). Milling Force Modeling: A Comparison of Two Approaches. *Procedia Manufacturing*, 5, 90–105. doi: <http://doi.org/10.1016/j.promfg.2016.08.010>
7. Tang, D. W., Wang, C. Y., Hu, Y. N., Song, Y. X. (2009). Finite-Element Simulation of Conventional and High-Speed Peripheral Milling of Hardened Mold Steel. *Metallurgical and Materials Transactions A*, 40 (13), 3245–3257. doi: <http://doi.org/10.1007/s11661-009-9983-1>
8. Grabchenko, A. I., Kal'chenko, V. I., Kal'chenko, V. V. (2009). *Shlifovanie so skreshchivayushchimisya osyami instrumenta i detali*. Chernigov: CHDTU, 356.
9. Kalchenko, V. I., Kalchenko, V. V., Sira, N. M., Kalchenko, D. V. (2016). Modulne 3D-modeliuvannya instrumentiv, protsesiv zniattia pryprysku ta formoutvorennia pry shlifuvanni zi skreshchenymi osyami tsylindrychnoho ta stupinchastoho vala i elborovoho kruha. *Rezanye y ynsument v tekhnolohycheskykh systemakh*, 86, 36–48. Available at: [http://repository.kpi.kharkov.ua/bitstream/KhPI-Press/24131/1/RITS\\_2016\\_%2086\\_Kalchenko\\_Modulne.pdf](http://repository.kpi.kharkov.ua/bitstream/KhPI-Press/24131/1/RITS_2016_%2086_Kalchenko_Modulne.pdf)
10. Krivoruchko, D. V., Zaloga, V. A. (2012). *Modelirovaniye proressov rezaniya metodom konechnykh elementov: metodologicheskie osnovy*. Sumy: Universitetskaya kniga, 496. Available at: <http://essuir.sumdu.edu.ua/handle/123456789/36676>

**Kalchenko Volodymyr**, Doctor of Technical Sciences, Professor, Department of Road Transport Industry and Mechanical Engineering, Chernihiv National University of Technology, Ukraine, ORCID: <http://orcid.org/0000-0002-9072-2976>, e-mail: [vokalchenko74@gmail.com](mailto:vokalchenko74@gmail.com)

**Kalchenko Vitaliy**, Doctor of Technical Sciences, Professor, Department of Road Transport Industry and Mechanical Engineering, Chernihiv National University of Technology, Ukraine, ORCID: <http://orcid.org/0000-0002-9850-7875>, e-mail: [kalchenkovi@ukr.net](mailto:kalchenkovi@ukr.net)

**Sira Nataliia**, PhD, Department of Road Transport Industry and Mechanical Engineering, Chernihiv National University of Technology, Ukraine, ORCID: <http://orcid.org/0000-0002-6242-5210>, e-mail: [nnseraya@gmail.com](mailto:nnseraya@gmail.com)

**Kuzhelnii Yaroslav**, PhD, Department of Road Transport Industry and Mechanical Engineering, Chernihiv National University of Technology, Ukraine, ORCID: <http://orcid.org/0000-0002-5269-8557>, e-mail: [k.y.v.immortal@gmail.com](mailto:k.y.v.immortal@gmail.com)

**Vynnyk Volodymyr**, Adjuster of Machine Tools and Manipulators with Programmed Control, PET Technologies, Chernihiv, Ukraine, ORCID: <http://orcid.org/0000-0002-4179-5765>, e-mail: [vovavynnyk7@gmail.com](mailto:vovavynnyk7@gmail.com)