



**Yevgeniy Trotsenko,
Mandar Madhukar Dixit,
Volodymyr Brzhezitsky,
Yaroslav Haran**

ALTERNATIVE EVALUATION OF VOLTAGE AT TOP OF TRANSMISSION LINE TOWER STRICKEN BY LIGHTNING

The object of the research is a circuit that simulates a lightning strike to a tower of 220 kV power transmission line, taking into consideration the reflection of a current wave from 10 nearest towers. Computation of the voltage arising at the top of the stricken tower is necessary further to determine the lightning performance of transmission line by various methods. For Indian conditions, the average number of lightning strikes to this power line per 100 kilometers per year is about 77, which is a fairly high figure. As a rule, for the tasks of lightning protection, the lightning current is approximated by some analytical expression. In most cases, such expressions are various combinations of exponential functions. However, the waveform of real lightning currents on oscillograms differs significantly from the waveform attributed to them and approximated by relatively simple exponential expressions. For a more detailed study of transient processes caused by thunderstorm activity, there is a need to use oscillograms of real lightning currents when modeling.

The problem of determining the voltage at the top of the stricken transmission line tower was solved using circuit simulation. To simulate the lightning current, digitized oscillograms of real lightning currents with peak values of -5.256 kA and -133.586 kA were applied.

The article shows that the proposed approach gives a more accurate and visual representation of the transient process at the top of the stricken tower than the approximation of the lightning current by simple exponential expressions. Applying a simplified exponential description of the lightning current leads not only to a simplification of the nature of the transient process at the tower top, but also to an underestimation of the results to 8.8%. The selection of the equivalent circuit for the power line towers also affects the result. Representation of towers in the equivalent circuit with lumped inductances leads to slightly higher values compared to application of surge impedances in the circuit. In this case, the smaller the current amplitude, the greater the difference (8.6% in the domain of low currents and 1.9% in the domain of high currents). Since this leads to some reserve during the computations of lightning performance, it is recommended to use an equivalent circuit with lumped inductance for a transmission line tower.

The conducted research contributes to the development of methods for calculating the lightning performance of power lines and extends the scope of application of circuit simulation programs.

Keywords: lightning flash, lightning performance, power line, wave reflection, oscillograms of real lightning currents.

Received date: 05.01.2021

Accepted date: 17.02.2021

Published date: 30.04.2021

© The Author(s) 2021

This is an open access article
under the Creative Commons CC BY license

How to cite

Trotsenko, Y., Dixit, M. M., Brzhezitsky, V., Haran, Y. (2021). Alternative evaluation of voltage at top of transmission line tower stricken by lightning. *Technology Audit and Production Reserves*, 2 (1 (58)), 33–39. doi: <http://doi.org/10.15587/2706-5448.2021.228659>

1. Introduction

A lightning strike directly to components of an overhead power line, to the ground or to other objects nearby can lead to insulation flashover and automatic outage of the line. In this case, a lightning strike to the power line causes the power supply interruptions to electricity consumers. In order to minimize the number of lightning outages, studying the lightning performance of power transmission lines is recommended. The number of lightning flashes to

ground, and, accordingly, to power transmission line depends on the intensity of thunderstorm activity in the area where the power transmission line is located. Since the subject of the authors' research is the power transmission lines of India, for this purpose it is necessary to take into consideration the available data on thunderstorm activity in this country. India has a variety of climatic zones with different thunderstorm activity [1]. According to the Indian standard IS 2309:1989 [2], the number of thunderstorm days per year varies from 1 (Azamgarh, Rajgangpur) to 103 (Sibsagar).

In recent years, lightning location systems have been widely developed in the world, which make it possible to obtain detailed statistics on the characteristics of lightning flashes in a certain area. According to the Vaisala Annual Lightning Report 2020 [3] in India for the period from 2016 to 2020, the average total lightning densities ranged from 8 to 32 (strokes/km²/year), which is a high figure. For comparison, the average total lightning densities in Ukraine over the same period ranged from 4 to 8 (strokes/km²/year).

Due to the high thunderstorm hazard, most of the publications are related to the analysis of fatalities caused by thunderstorm activity [4], and an insufficient number of publications are devoted to the electric power industry. Taking into account the long distance of alternating current (AC) power transmissions, as well as the development of direct current (DC) power transmissions [5], assessing the impact of lightning flashes to power lines in various regions of India is important. Overvoltages caused by a direct lightning strike to a power line pose the greatest danger, therefore, when computing the lightning performance of lines, it is necessary to focus primarily on this type of overvoltage.

Therefore, it is relevant to develop effective approaches for studying the processes in a power transmission tower stricken by lightning. Computation of an electric potential arising at the top of the tower stricken is necessary subsequently to determine the lightning performance of the line by various methods.

Thus, *the object of research* is an equivalent circuit designed to simulate a lightning strike to a power line tower. For detailed visualization of the transient process at the top of the stricken tower, digitized oscillograms of real lightning currents were used.

In its turn, *the aim of the article* is to study how the equivalent circuit of the power transmission line towers affects the voltage curve at the top of the stricken tower when using digitized oscillograms of real lightning currents.

2. Methods of research

It has been assumed that the number of lightning flashes to ground or to power transmission line in specific locality is roughly proportional to the annual thunderstorm days in that locality. According to [6], for India, the empirical relationship between cloud-to-ground lightning density and annual thunderstorm days is given by:

$$N = 0.1T, \quad (1)$$

where N is the number of lightning flashes to ground per square kilometer per year; T is the number of thunderstorm days in year. Average annual number of thunderstorm days for a given locality is also called a keraunic level.

It has been established by laboratory experiments and observations that a section of a power transmission line with length l receives lightning strikes on average from an area S :

$$S = W \cdot l. \quad (2)$$

According to [6]:

$$W = b + 4h^{1.09}, \quad (3)$$

where W is so-called «shadow width» on earth's surface, m; h is the mean shield wire height of the power transmission

line, m; b is the distance between shield wires for single or double circuit towers with double shield wires, m. For single or double circuit towers with single shield wire $b=0$. The mean shield wire height is given by:

$$h = h_g - \frac{2}{3}(h_g - h_{gw}), \quad (4)$$

where h_g is the height of shield wire at the transmission tower, m; h_{gw} is the shield wire midspan clearance to ground, m. If h_{gw} is not known exactly, then for preliminary calculations it can be assumed that $h=(0.7...0.9)h_g$.

It has usually been assumed that number of lightning flashes to power transmission line is calculated per 100 kilometers of line length. Multiplying expression (3) by 10^{-3} to convert meters to kilometers, according to (1)–(4), one can obtain the expression for determining the number of lightning strikes to power transmission line:

$$N_L = 0.1T(b + 4h^{1.09}) \cdot 10^{-3} \cdot 100 = 0.01T(b + 4h^{1.09}), \quad (5)$$

where N_L is the number of lightning flashes to power transmission line per 100 kilometers per year for India; T is the number of thunderstorm days in year for a specific locality; h is the mean shield wire height of the power transmission line, m.

Let's roughly estimate the number of lightning strikes to a 220 kV power transmission line. For this, one will use a double-circuit power transmission line tower with single shield wire [7]. Since the designs of power transmission line towers of the same voltage class in different countries can differ significantly, a 220 kV tower, which is used in India, was selected for the research. A drawing of the tower structure is shown in Fig. 1.

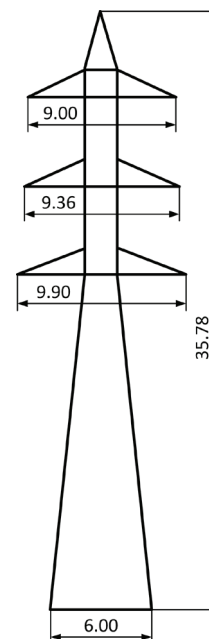

Fig. 1. Basic dimensions (m) of the transmission line tower

Assuming that $h = 0.8 \cdot 35.78 = 28.62$ for a region with the number of thunderstorm days in year equal to 50, according to (5), the number of lightning strikes to a given power line per 100 kilometers per year will be about 77. The probability of lightning striking directly to the tower

depends on the tower height h_t and the power line span length l_s [8]:

$$P_t \approx 4 \frac{h_t}{l_s}, \tag{6}$$

where P_t is the probability of lightning striking the power line tower; h_t is the tower height, m; l_s is power line span length, m.

Then the number of lightning strikes directly to the power line towers per 100 kilometers per year is defined by the expression:

$$N_t = N_L P_t. \tag{7}$$

The span length between two adjacent transmission line towers was assumed to be 350 m, which corresponds to the typical value for lines of this voltage class. Then, according to (6), for the considered tower, the probability of lightning striking the power line tower is $P_t=0.409$ or 40.9 %. According to (5) and (7), the number of lightning strikes directly to the transmission line towers per 100 kilometers per year is about 31.

It should be noted that not every lightning strike to a tower leads to an automatic outage of the line, however, it matters. Therefore, further it is necessary to assess what electric potential can arise at the top of the tower in the case of a lightning strike. As an object of research, a case that corresponds to a lightning strike to the top of a power line tower was selected. It has been assumed [6] that due to the sagging of the wires in the midspan, in about 60 % of cases lightning strikes directly to the towers and in about 40 % of cases lightning strikes to the wires in the midspan. Therefore, this case can be considered as common. Fig. 2 shows a fragment of the simulation circuit, which takes into consideration the reflection of waves from adjacent power line towers. In the equivalent circuit, both lightning protection shield wire and power line towers are represented by transmission line models with certain surge impedances [9].

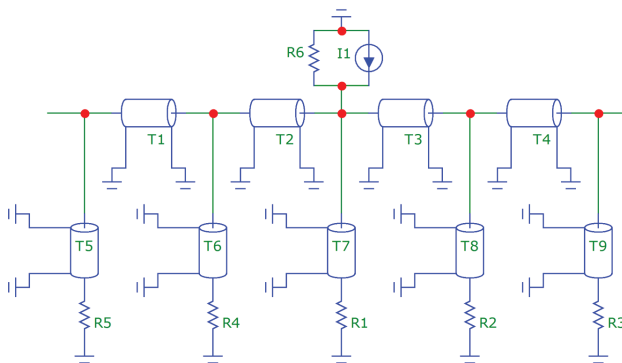

Fig. 2. Circuit simulation of a lightning strike to a power line tower, taking into consideration the reflection of electromagnetic waves from adjacent towers

The circuit diagram in Fig. 2 takes into consideration that waves will travel along the lightning protection shield wire to the left and to the right from the tower stricken by lightning. The wave magnitude is equal to the voltage at the top of the stricken tower. In Fig. 2: T_1-T_4 are the transmission line models simulating lightning protec-

tion shield wires; T_5-T_9 are the transmission line models simulating overhead transmission line towers; R_1-R_5 are the tower grounding resistances; R_6 is lightning channel equivalent impedance; I_1 is lightning current source.

According to [10], the equivalent surge impedance of the power line tower shown in Fig. 1 can be computed by formula (8).

$$Z_t = 30 \ln \left(\frac{2(h_t^2 + r_t^2)}{r_t^2} \right) = 30 \ln \left(\frac{2(35.78^2 + 3^2)}{3^2} \right) = 169.7 \, \Omega, \tag{8}$$

where $h_t=35.78$ m – transmission line tower height; $2r_t=6$ m – the diameter of the circle the base of the power line tower is stand on.

The surge impedance of the lightning protection shield wire was assumed to be 500 Ω . The impulse corona affects the speed of propagation of the electromagnetic wave along the wire. Therefore, it is usually assumed that an electromagnetic wave travels along the lightning protection shield wire at a speed of $0.9c$ ($c=3 \cdot 10^8$ m/s), and from the top to the base of the tower, the wave travels at the speed of light c . Then, for a given line, the time of wave propagation from the top to the base of the tower will be:

$$\frac{35.78}{3 \cdot 10^8} = 1.193 \cdot 10^{-7} \text{ s} = 0.1193 \, \mu\text{s},$$

and in its turn, the time of wave propagation between two adjacent towers will be:

$$\frac{350}{0.9 \cdot 3 \cdot 10^8} = 1.296 \cdot 10^{-6} \text{ s} = 1.296 \, \mu\text{s}.$$

The footing resistances of the towers (R_1-R_5) were assumed to be 20 Ω . The lightning channel equivalent impedance (R_6) was assumed to be 400 Ω . In fact, the resistance of the lightning discharge channel at the stage of the main discharge does not remain constant, decreasing as the lightning current increases. In most calculations, the resistance of the lightning discharge channel is recommended to be considered equal to 400 Ω , 1000 Ω [11] or infinite. Computation of lightning performance indicators of overhead transmission lines with a lightning channel equivalent impedance equal to infinity leads to a certain overestimation when calculating the number of lightning outages caused by lightning strikes to phase conductors.

A simplified circuit diagram for determining the voltage at the top of a tower without taking into consideration the reflection of the current wave from adjacent towers is shown in Fig. 3.

In the electrical circuit in Fig. 3 lightning protection shield wires are replaced with their surge impedances R_7 and R_8 . Simulation of electrical circuits in Fig. 2 and Fig. 3 was performed using the Micro-Cap 12 circuit simulation program [12]. In addition to using a transmission line models, the power line tower in the circuit diagram can be represented by lumped inductance (refer to Fig. 4), as well as more complex circuits.

Determining the tower inductance (L_1-L_5) is a challenge. In the absence of more accurate data, for such type of towers as in Fig. 1, the average inductance per one meter

of the tower height is approximately $0.5 \mu\text{H}/\text{m}$ [8]. Then, for the circuit diagram in Fig. 4, the lumped inductance of each tower is equal to $21.468 \mu\text{H}$. With such an approach the transmission line model T_7 in Fig. 3 also needs to be replaced with lumped inductance.

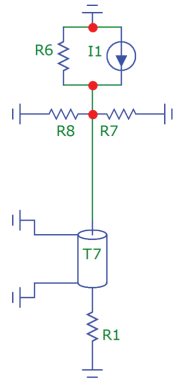

Fig. 3. Circuit simulation of a lightning strike to a power line tower, without taking into consideration the reflection of electromagnetic waves from adjacent towers

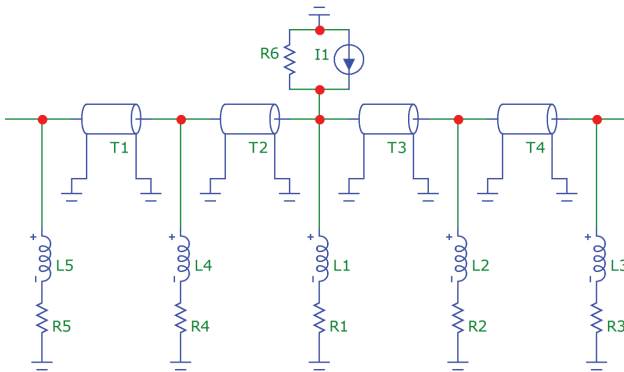

Fig. 4. Power line towers are represented in the electrical circuit by lumped inductances

Among the lightning flashes that occur between clouds and the ground, as a rule, four main types are distinguished by the direction (from cloud to ground, and vice versa, from ground to cloud) and by polarity (positive or negative). In the latter case, the sign of the cloud charge, which is neutralized during the lightning strike, is meant. Lightning flashes that start from a part of a thundercloud with negative charges and propagate towards the ground make up the largest number (up to 90 %) among the all flashes between clouds and the ground. Therefore, in this article, oscillograms of negative lightning impulses were used for simulation. As a rule, the lightning current is approximated by some analytical expression. In most cases, such expressions are various combinations of exponential functions [13]. However, the waveform of real lightning currents on oscillograms differs significantly from the waveform attributed to them and approximated by relatively simple exponential expressions. The application of oscillograms of real lightning currents has shown its effectiveness when researching the surge arresters [14, 15]. Undoubtedly, the application of real lightning oscillograms also has some disadvantages. Oscillograms of lightning current waves may contain numerous additional details, which are caused, for example, by multiple reflections of

current impulses between the ends of a tall object stricken by lightning and other reasons.

3. Research results and discussion

For detailed visualization of the transient process at the top of the stricken tower, digitized oscillograms of real lightning currents were used [16, 17]. Oscillograms were digitized and converted into an array of points using the free software WebPlotDigitizer [18]. A digitized oscillogram of lightning current impulse with a small amplitude is shown in Fig. 5. In fact, such a curve is a piecewise linear function where adjacent points are connected by line segments. The curve has two characteristic peaks. The amplitude of the first peak is -4.681 kA , the amplitude of the second peak is -5.256 kA .

Fig. 6 shows the simulation results for the case when the power line towers are represented by surge impedances in the electrical circuit. Here and below, the blue color is stand for the voltage curve at the top of the stricken tower, taking into account the multiple reflection of the current wave from adjacent towers. The red color is stand for the voltage curve at the top of the stricken tower without taking into account the influence of adjacent towers. The simulation circuit takes into account the reflections of current waves from 10 adjacent towers (5 to the left and 5 to the right of the stricken tower).

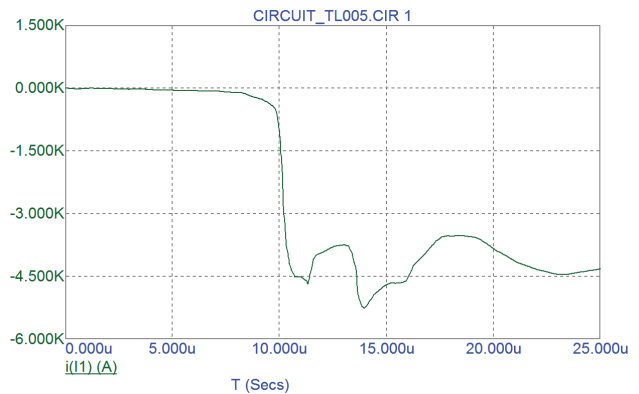

Fig. 5. Current curve with the highest value of -5.256 kA

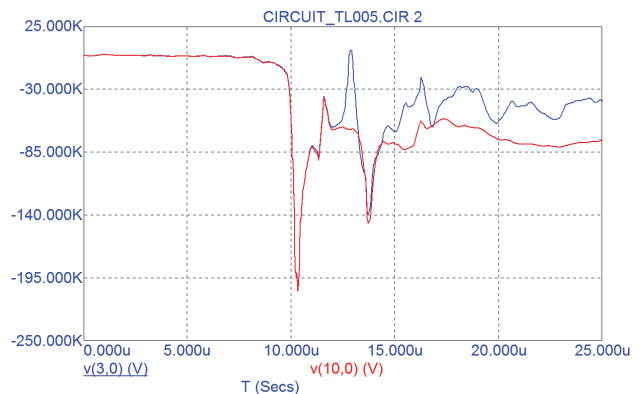

Fig. 6. Tower top voltage at a current of -5.256 kA (towers are represented by surge impedances)

The simulation results for the case when the power line towers are represented in electrical circuit by lumped inductances are shown in Fig. 7.

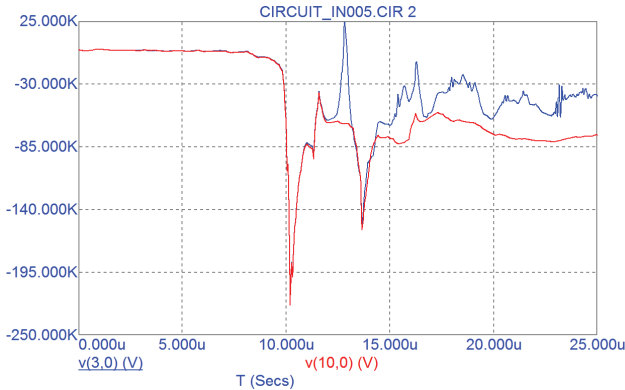

Fig. 7. Tower top voltage at a current of -5.256 kA (towers are represented by lumped inductances)

As one can see in Fig. 6 and Fig. 7, the highest voltage value at the tower top is due to the first current peak (-4.681 kA), and not the second peak (-5.256 kA).

A digitized oscillogram of a lightning current impulse with a high amplitude is shown in Fig. 8.

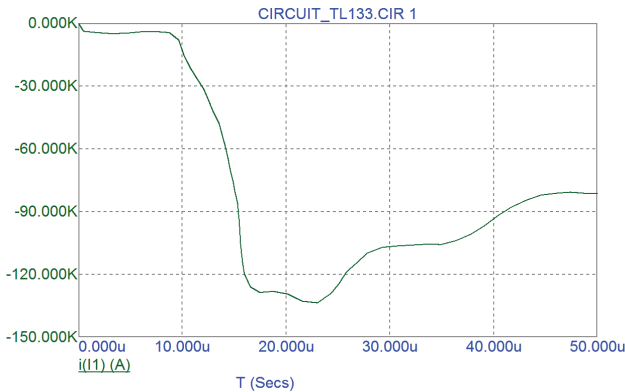

Fig. 8. Current curve with the highest value of -133.586 kA

Similar simulation results for two cases of representing the power line towers in electrical circuits are shown, respectively, in Fig. 9 and Fig. 10.

The probability of occurring the lightning currents with an amplitude exceeding a certain value I can be estimated by the formula [6]:

$$P_I = \frac{1}{1 + \left(\frac{I}{31}\right)^{26}}, \quad (9)$$

where I is the peak value of the lightning current in kiloamperes; P_I is the probability that in a flash the amplitude of the lightning current will exceed the value I .

According to (9), the probability of occurring a lightning current with an amplitude exceeding the amplitude of the first current is 0.990 or 99.0 %. In its turn, the probability of occurring a lightning current with an amplitude exceeding the amplitude of the second current is 0.022 or 2.2 %.

As a result of the simulation, the following was established. In the case of a direct lightning strike to a power line tower, the tower top voltage can theoretically reach values that are dangerous for insulation. The circuit diagram in Fig. 3 can only be used to estimate the maximum value

at the tower top before the arrival of waves reflected from adjacent towers. However, even in this case, the result obtained will be somewhat overestimated. For example, in the first case it is -206.019 kV (refer to circuit in Fig. 3) compared to -205.536 kV (refer to circuit in Fig. 2). In the second case, it is -2.974 MV (refer to circuit in Fig. 3) compared to -2.739 MV (refer to circuit in Fig. 2).

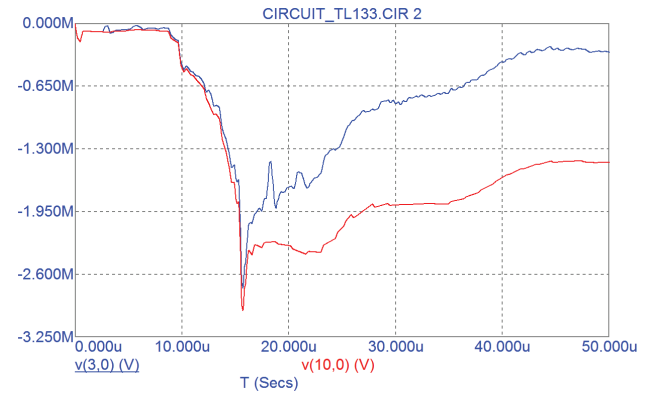

Fig. 9. Tower top voltage at a current of -133.586 kA (towers are represented by surge impedances)

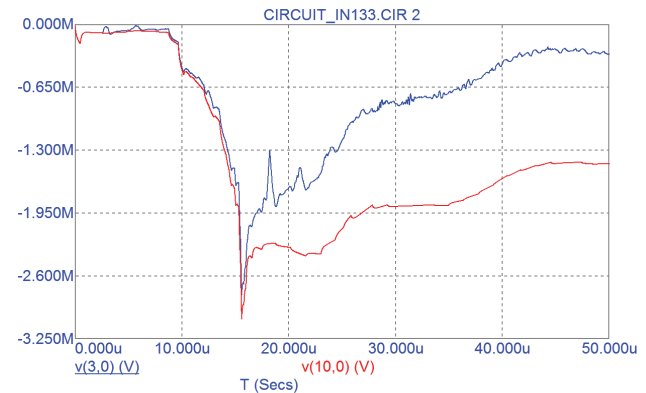

Fig. 10. Tower top voltage at a current of -133.586 kA (towers are represented by lumped inductances)

Upon completion of the front of the lightning current impulse, the voltage at the top of the stricken tower begins to decrease significantly due to multiple reflections of waves from adjacent power line towers. Comparison of Fig. 6 with Fig. 7 and, in turn, Fig. 9 with Fig. 10 allows concluding that the representation of towers in the equivalent circuit by lumped inductances leads to slightly higher values compared to the use of surge impedance representation. In this case, the smaller the current amplitude, the greater the difference (8.6 % at low current and 1.9 % at high current). Thus, the improvement of the power line tower equivalent circuit should be the subject of further research. According to IEC 60071-1:2011 [19], the insulation of electrical equipment with a maximum operating voltage of 245 kV must withstand the full lightning impulse test of 1050 kV. The tower top voltages obtained in the article allow concluding that with the first current, the flashover of suspension insulators will not happen, with the second current, the flashover is inevitable. Such a conclusion is possible because in the article, knowingly low and, on the contrary, high currents were used. The first current (Fig. 5) leads to a voltage at the top of stricken tower, which is

significantly less than the impulse strength required by the standard. In the second case (Fig. 8), the result, on the contrary, exceeds the required impulse strength several times. In the general case, after calculating the tower top voltage, it is necessary to calculate the voltage drop across the suspension insulators and compare it with the voltage-time curve of the insulator string. Further research showed that detailed voltage curves at the top of the stricken tower can't be obtained in the case of using the approximation of the current by simplified exponential functions. Here are just some of the results. For example, Fig. 11 shows the idealized current curve that most closely matches the curve in Fig. 5. The amplitude of the first peak in Fig. 5 and the maximum current in Fig. 11 are the same and equal to -4.681 kA. In turn, Fig. 12 shows the curves of tower top voltages at this idealized current.

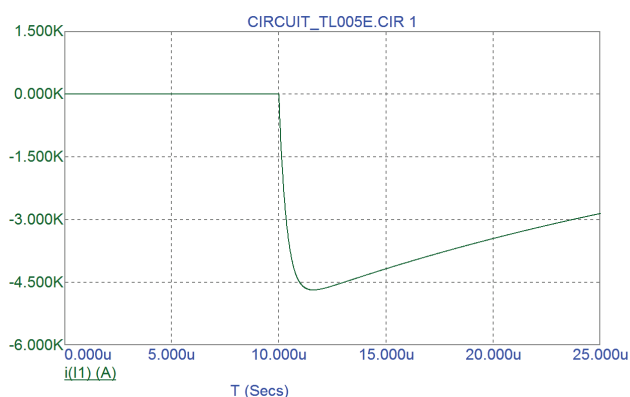

Fig. 11. Idealized current impulse with a peak value of -4.681 kA

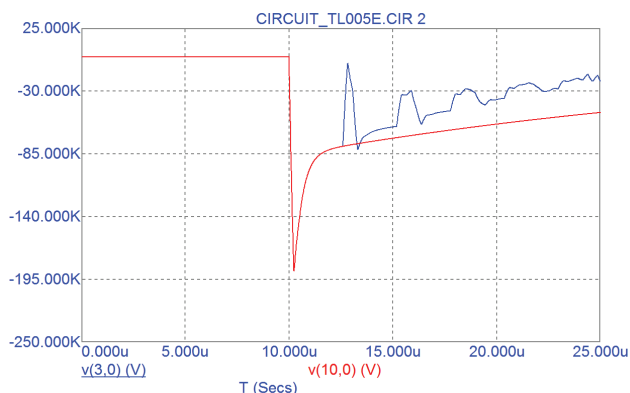

Fig. 12. Tower top voltage at idealized current of -4.681 kA (towers are represented by surge impedances)

Comparing the curves in Fig. 6 and Fig. 12, one can see that the use of an idealized (exponential) description of the lightning current leads to a noticeable simplification of the nature of the transient process at the tower top. It also leads to an underestimated value of the maximum voltage at the tower top, namely -187.362 kV compared to -205.536 kV, which corresponds to a difference of 8.8% .

The approximation of lightning current impulse by the closest piecewise linear functions gives the most visual representation of the transient process at the top of the stricken. This was demonstrated by the example of two lightning currents. Such an approach using oscillograms of real lightning currents is of interest for further research. The available data on thunderstorm activity in different

regions of India shows that lightning protection of overhead power lines requires special attention. In general, the procedure for assessing the lightning performance of power lines can be based on various models and assumptions. However, in any case, the procedure for calculating the lightning performance of power lines requires data on the available characteristics of lightning, the structure of the power line and voltage levels, the type of overvoltage and other necessary characteristics. Therefore, in further research, it is advisable studying the use of oscillograms of lightning currents typical for the region under consideration. In this regard, it is recommended to measure lightning currents on the power line towers (for example, by traditional method using Rogowski coils) under conditions of different regions.

4. Conclusions

Oscillograms of real lightning currents recorded in power systems were digitized and converted into an array of points. Voltage arising at the top of a double-circuit tower of a 220 kV power transmission line, stricken by lightning, using the curves of real lightning currents with peak values of -5.256 kA and -133.586 kA was simulated and visualized. It is shown that this approach gives a more accurate and visual representation of the transient process at the top of the stricken tower than the approximation of the lightning current by simple exponential expressions. Applying an idealized (exponential) expression of the lightning current leads not only to a simplification of the nature of the transient process at the tower top, but also to an underestimation of the results to 8.8% . Thus, applying the oscillograms of real lightning currents contributes to an increase in the accuracy when calculating the lightning performance of power lines and studying the atmospheric overvoltage in power systems in general. The selection of the equivalent circuit for the power line towers also affects the result. Representation of towers in the equivalent circuit with lumped inductances leads to slightly higher values compared to application of surge impedances in the circuit. In this case, the smaller the current amplitude, the greater the difference (8.6% in the domain of low currents and 1.9% in the domain of high currents). Since this leads to some reserve during the computations of lightning performance, it is recommended to use an equivalent circuit with lumped inductance for a power line tower.

References

- Nath, A., Manohar, G. K., Dani, K. K., Devara, P. C. S. (2009). A study of lightning activity over land and oceanic regions of India. *Journal of Earth System Science*, 118 (5), 467–481. doi: <http://doi.org/10.1007/s12040-009-0040-7>
- Indian Standard IS 2309:1989, *Protection of buildings and allied structures against lightning – Code of practice (Second Revision)* (1991). Bureau of Indian standards, 64.
- Vaisala Annual lightning report 2020. Ref. B212260EN-A (2021). Vaisala. Available at: <https://www.vaisala.com/sites/default/files/documents/WEA-MET-Annual-Lightning-Report-2020-B212260EN-A.pdf>
- Holle, R. L. (2008). Annual Rates of Lightning Fatalities by Country. *20th International lightning detection conference*, 1–14.
- Kamalapur, G. D., Sheelavant, V. R., Hyderabad, S., Pujar, A., Baksi, S., Patil, A. (2014). HVDC Transmission in India. *IEEE Potentials*, 33 (1), 22–27. doi: <http://doi.org/10.1109/mpot.2012.2220870>
- LaForest, J. J. (Ed.) (1982). *Transmission line reference book (345 kV and above)*. Electric Power Research Institute. Palo Alto, 640.

7. Halkude, S. A., Ankad, P. P. (2014). Analysis and Design of Transmission Line Tower 220 kV: A Parametric Study. *International Journal of Engineering Research & Technology*, 3 (8), 1343–1348.
8. Bazutkin, V. V., Kadomskaia, K. P., Kostenko, M. V., Mikhailov, Iu. A. (1995). *Perenapriazheniia v elektricheskikh sistemakh i zaschita ot nikh*. Saint Petersburg: Energoatomizdat. Otdelenie, 320.
9. Melo, M. O. B. C., Fonseca, L. C. A., Fontana, E., Naidu, S. R. (1997). Lightning Performance of Compact Transmission Lines. *International Conference on Power Systems Transients*. Seattle, 319–324.
10. Sargent, M. A., Darveniza, M. (1969). Tower Surge Impedance. *IEEE Transactions on Power Apparatus and Systems, PAS-88* (5), 680–687. doi: <http://doi.org/10.1109/tpas.1969.292357>
11. Datsios, Z. G., Mikropoulos, P. N., Tsovilis, T. E. (2019). Effects of Lightning Channel Equivalent Impedance on Lightning Performance of Overhead Transmission Lines. *IEEE Transactions on Electromagnetic Compatibility*, 61 (3), 623–630. doi: <http://doi.org/10.1109/temc.2019.2900420>
12. *Micro-Cap 12. Electronic Circuit Analysis Program. Reference Manual* (2018). Sunnyvale: Spectrum Software, 1098. Available at: <http://www.spectrum-soft.com/download/rm12.pdf>
13. De Conti, A., Visacro, S. (2007). Analytical Representation of Single- and Double-Peaked Lightning Current Waveforms. *IEEE Transactions on Electromagnetic Compatibility*, 49 (2), 448–451. doi: <http://doi.org/10.1109/temc.2007.897153>
14. Trotsenko, Y., Brzhezitsky, V., Mykhailenko, V. (2019). Revised Effect of Inductive Voltage Drop Across Line Lead on Protective Level of Surge Arrester. *2019 IEEE 2nd Ukraine Conference on Electrical and Computer Engineering (UKRCON)*. Lviv, 341–344. doi: <http://doi.org/10.1109/ukrcon.2019.8879939>
15. Trotsenko, Y., Brzhezitsky, V., Mykhailenko, V. (2020). Estimation of Discharge Current Sharing Between Surge Arresters with Different Protective Characteristics Connected in Parallel. *2020 IEEE 7th International Conference on Energy Smart Systems (ESS)*. Kyiv, 73–78. doi: <http://doi.org/10.1109/ess50319.2020.9160296>
16. Hussein, A. M., Janischewskyj, W., Milewski, M., Shostak, V., Rachidi, F., Chang, J. S. (2003). Comparison of current characteristics of lightning strokes measured at the CN Tower and at other elevated objects. *2003 IEEE Symposium on Electromagnetic Compatibility. Symposium Record (Cat. No.03CH37446)*. Boston, 2, 495–500. doi: <http://doi.org/10.1109/isemc.2003.1236651>
17. Narita, T., Yamada, T., Mochizuki, A., Zaima, E., Ishii, M. (2000). Observation of current waveshapes of lightning strokes on transmission towers. *IEEE Transactions on Power Delivery*, 15 (1), 429–435. doi: <http://doi.org/10.1109/61.847285>
18. Rohatgi, A. (2020). *WebPlotDigitizer. Version 4.4. Pacifica*. Available at: <https://automeris.io/WebPlotDigitizer>
19. *IEC 60071-1:2011. Insulation co-ordination – Part 1: Definitions, principles and rules* (2011). Geneva: IEC Central Office, 74.

Yevgeniy Trotsenko, PhD, Associate Professor, Department of Theoretical Electrical Engineering, National Technical University of Ukraine «Igor Sikorsky Kyiv Polytechnic Institute», Kyiv, Ukraine, e-mail: y.trotsenko@kpi.ua, ORCID: <https://orcid.org/0000-0001-9379-0061>

Mandar Madhukar Dixit, Assistant Professor, Department of Electrical Engineering, Vishwaniketan Institute of Management Entrepreneurship and Engineering Technology, Maharashtra, India, e-mail: mmdixit@vishwaniketan.edu.in, ORCID: <https://orcid.org/0000-0003-1959-7815>

Volodymyr Brzhezitsky, Doctor of Technical Sciences, Professor, Department of Theoretical Electrical Engineering, National Technical University of Ukraine «Igor Sikorsky Kyiv Polytechnic Institute», Kyiv, Ukraine, e-mail: v.brzhezitsky@kpi.ua, ORCID: <http://orcid.org/0000-0002-9768-7544>

Yaroslav Haran, PhD, Assistant, Department of Theoretical Electrical Engineering, National Technical University of Ukraine «Igor Sikorsky Kyiv Polytechnic Institute», Kyiv, Ukraine, e-mail: y.garan@kpi.ua, ORCID: <https://orcid.org/0000-0003-3242-9218>