



**Liudmyla Perchevska,  
Oleksandr Drozdenko,  
Kateryna Drozdenko,  
Oleksandr Leiko**

## STUDY OF THE INFLUENCE OF THE HOUSING ON THE COOLING EFFICIENCY OF THE PIEZOCERAMIC ELECTROACOUSTIC LANGEVIN-TYPE TRANSDUCER

The object of research is thermal processes in Langevin-type piezoceramic electroacoustic transducers (PET), taking into account the housing. The piezoceramic electroacoustic transducers heat up during operation. Overheating of the converter leads to negative consequences, accompanied by a change in the parameters, characteristics of the device, as well as the failure of the converter. Or limitation on the duration and mode of operation, output power, current, amplitude and speed of oscillation of the converter.

The paper investigates the effect of the housing on the temperature field of a Langevin-type PET by the finite element method, using modeling in SolidWorks. The results of temperature reduction of such cooling methods are shown:

- filling the housing cavity with electrical insulating liquid, gas, a mixture of thermal paste;
- use of holes in the housing;
- changing the shape of the rear cover to have radiator side fins, vertical radiator fins, cylindrical radiator fins;
- heat-resistant layer;
- use of active air cooling at three different speeds.

The most efficient 53 % and a uniform temperature field were found when filling with a mixture of thermal paste, but this solution is accompanied by additional experiments and a preparatory stage with the mixture. The cooling efficiency of 47 % was provided by active cooling – blowing with air, and this method requires additional equipment. Filling with insulating liquid gave a cooling efficiency of 27 % – an optimal result that does not require expensive investments. Slow blowing of the housing or adding only holes resulted in a decrease in the maximum heating temperature from 10 to 20 %, therefore, if the PET design allows the presence of holes, then it is necessary to rationally place them. Changing the shape of the back plate, heat-absorbing element, filling the housing with gas gave an efficiency decrease in the maximum temperature by 6–8 % compared to a closed housing with air.

The research results make it possible to choose the optimal option for reducing the heating temperature of the Langevin-type PET to increase its efficiency and long-term trouble-free operation.

**Keywords:** piezoceramic electroacoustic transducer, Langevin-type transducer, rod transducer, transducer heating, transducer thermal field.

Received date: 12.01.2021

Accepted date: 19.02.2021

Published date: 30.06.2021

© The Author(s) 2021

This is an open access article

under the Creative Commons CC BY license

### How to cite

Perchevska, L., Drozdenko, O., Drozdenko, K., Leiko, O. (2021). Study of the influence of the housing on the cooling efficiency of the piezoceramic electroacoustic langevin-type transducer. *Technology Audit and Production Reserves*, 3 (1 (59)), 50–55. doi: <http://doi.org/10.15587/2706-5448.2021.231279>

### 1. Introduction

Piezoceramic electroacoustic transducers (PET) convert electrical energy into mechanical energy and vice versa, thanks to piezoelectric ceramics. Rod-type PETs, or Langevin-type, in their design contain a rear mass, piezoelectric ceramics and a radiating mass. Such transducers are used both in a liquid medium, for example, in underwater acoustics, and in the air – ultrasonic technological equipment, an ultrasonic motor, a piezotransducer, some medical equipment [1], rock drilling devices [2]. During operation, the transducer is subjected to opera-

tional loads – electrical, mechanical, cavitation, thermal. When working in an aqueous medium, the transducer housing is washed by a liquid, therefore, heating has a less pronounced effect, but temperature stresses in the antenna have [3]. When the PET is operating in air, the transducer housing creates an additional volume and heats up quickly. The housing is used for ease of use of the device and for mechanical protection of the transducer design elements, such as piezoceramics, electrical connections. Even in the presence of a large volume of air in the housing, the problem of heating remains, as, for example, in an ultrasonic cleaner [4].

Therefore, it is relevant to study the PET warm field. The study of the features of heating the transducer and the efficiency of its cooling, taking into account the housing, is a promising task, the solution of which will provide additional information that will help in the process of designing electroacoustic transducers.

## 2. The object of research and its technological audit

*The object of research* is the thermal processes in the Langevin-type PET taking into account the housing.

A piezoceramic electroacoustic transducer of the Langevin type (rod type), consisting of two passive plates (rear and emitting plates), an active element, and a washer, which are collected by a bolt (Fig. 1), is investigated. The housing is attached to the transducer through a mechanical isolation element. Emitting plate 1 is made of AMg6 aluminum alloy in the form of a truncated cone with a large diameter of 60 mm, a smaller diameter of 38 mm and a thickness of 30 mm. Back plate 2, washer 3, bolt 4 are made of AISI 1020 steel. The outer diameter of the cylindrical back plate is 50 mm, the inner diameter is 17 mm. An M16 tie bolt, 82 mm long, is screwed into the radiating plate by 10 mm and sealed with a washer 36 mm in diameter, 2 mm thick. Casing 5 is cylindrical, made of aluminum, clad on the transducer through a fastening ring from compound 6. Active element 7 is 4 rings made of APC-840 piezoelectric ceramics, outer diameter 38 mm, inner diameter 17 mm, thickness 10 mm each. The transducer operates in air, the power loss is 15 W. The initial temperature is 25 °C. Note that these parameters are not related to a specific transducer, but carry the collective characteristics of the most used Langevin-type transducer.

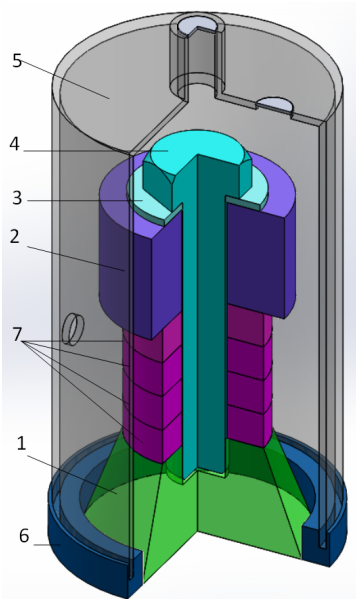

**Fig. 1.** Model of a piezoceramic electroacoustic transducer of the Langevin type: 1 – emitting plate; 2 – back plate; 3 – washer; 4 – bolt; 5 – casing; 6 – fastening ring; 7 – active element

When the transducer is heated, its parameters and characteristics change, for example:

- shift of the operating frequency [5];
- change in electrical resistance [6];

- violation of the agreement with the electronic generator [7] due to a change in the electrical capacitance of the piezoelectric ceramics [8].

With an increase in temperature, irreversible consequences also occur: thermal aging, degradation [9, 10], depolarization of piezoelectric ceramics. The properties of the first generation piezoelectric ceramics are especially unstable with increasing temperature [11], and the piezoelectric coefficients of soft piezoceramics are more susceptible to changes [12, 13]. There are also a number of restrictions imposed on the transducer in order to avoid heating – restrictions on the duration and mode of its operation, output power, electric current, amplitude and speed of oscillations [14, 15].

The addition of housing to the investigated PET will allow taking into account these additional elements that are in the designs of real transducers. The introduction of additional structural elements leads to a change in the thermal field of the entire probe, which must be taken into account when designing. It should be noted that this issue has not been practically studied in the literature. Some aspects of the thermal field of a Langevin-type transducer were considered earlier [16–18].

However, there is very little research into the temperature of a transducer in housing. At that time, it is important not to neglect even the housing fastening when calculating the total transducer losses [19]. To increase the efficiency of the transducer, it is necessary to reduce the waste of energy spent on heating it.

## 3. The aim and objectives of research

*The aim of research* is to investigate how the presence of housing affects the thermal field of a Langevin-type PET, as well as the effectiveness of constructive measures to reduce the heating of the structure of this transducer.

To achieve the aim, the following objectives have been set:

1. To quantify the effect of the housing on the heating temperature of the transducer.
2. To analyze methods of reducing the heating temperature of the transducer, suitable for Langevin-type transducers.
3. To identify the most effective cooling methods for PET, taking into account the casing.

## 4. Research of existing solutions to the problem

To establish the normal thermal regime of the device, which includes a piezoceramic electroacoustic transducer, a decrease in the duration of operation, the power of the device is used and its operating mode is changed. To increase the efficiency, respectively, reduce the dissipated power, it is recommended to work not at the resonant frequency [20]. But this is not always the best solution. In some housings, it is justified to use more temperature-resistant materials – a piezoceramic composite [10], materials with a high operating temperature. So, in [21], an additional layer of aluminum and a graphite tape is used as an additional heat-absorbing element. To cool the rod transducer, heat-conducting layers of a larger size are used [18, 22]. The authors of [23] proposed to use a layer with a special mixture of a filling material and a heat-conducting powder to remove heat in the transducer housing. Active methods are also used, such as pressurized coolant [24] or air blowing with

a fan. For a greater decrease in the heating temperature, it is proposed to combine heat-conducting layers with cooling gas blowing [25].

However, options with active cooling require additional equipment. An alternative solution to the problem is to change the shape of the back plate [16] and the tightening bolt [2].

However, the proposed shape changes are difficult to manufacture. Work [26] is devoted to increasing the power of the transducer and the number of radiating frequencies, but the study of temperature was not carried out. However, changing the shape of the emitting plate also has a positive effect on the heating temperature of the transducer.

All of the above methods give good results in reducing the warm-up temperature, however their effectiveness is not known when using a transducer housing. Thus, the results of the analysis lead to the conclusion that it is necessary to identify the most effective cooling methods that can be used for the transducer in the housing.

## 5. Methods of research

The study was carried out by modeling in the SolidWorks environment in the Flow Simulation application. An analytical calculation of the thermal field of a rod transducer can be obtained by solving the Fourier thermal conductivity equation, replacing the PET components with a system of layers. This option is suitable for a rough estimate of the heating temperature of the transducer and quite accurately coincides with the simulation results for rod and cylindrical transducers excluding the housing [27, 28]. But the analytical calculation is difficult to take into account the housing, due to the impossibility of replacing the volume of the cavity in the housing with an infinite layer.

To solve the assigned tasks in SolidWorks, the PET components were created and materials were assigned to them. In Flow Simulation, the external analysis type, thermal conductivity, gravity, coolants – air, gas, electrical insulating liquid, initial conditions (pressure 101325 Pa and temperature 25 °C) were set.

## 6. Research results

**6.1. Adding a housing.** Let's compare the PET temperature fields without a housing (Fig. 2, *a*) and with it (Fig. 2, *b*). For more convenience, let's show the temperature distribution on the same color scale. The brown arrow indicates the direction of gravity.

In Fig. 2, *a* the maximum temperature of piezoelectric ceramics is 140 °C, which is within the operating temperature range for this type, but outside the normal thermal regime. The addition of the housing increased the temperature by 64 °C, it is impossible not to take into account when designing the transducer.

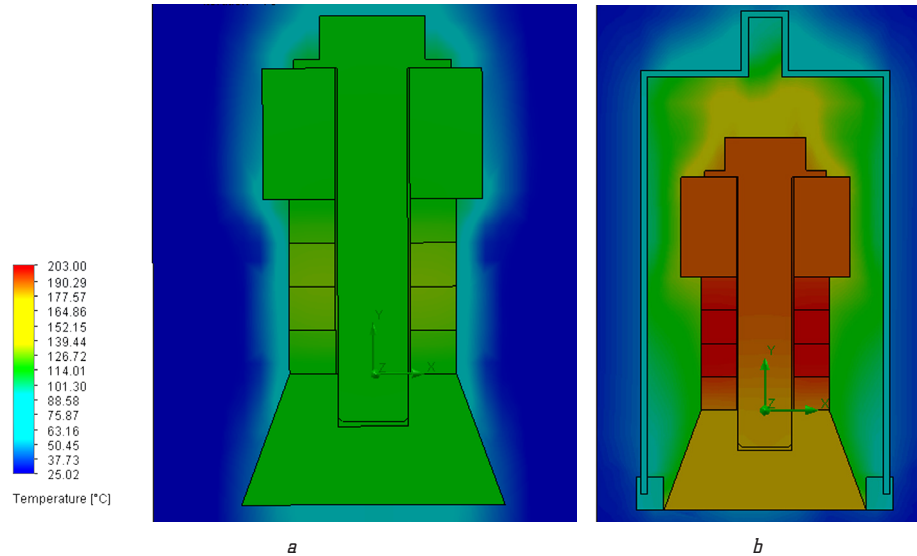

**Fig. 2.** Thermal field of piezoceramic electroacoustic transducer:  
*a* – excluding the housing; *b* – taking into account the housing

**6.2. Filling the housing cavity.** The use of a sealed enclosure is often a prerequisite for PET and it is rarely important to fill it with air only, as there is the potential for electrical breakdown. Let's show the advantages of filling the housing, focusing on reducing the maximum heating temperature. The most popular filling – insulating liquid, allowed to reduce the maximum temperature by 56 °C. It is also often filled with an inert gas, for example, in neon 0.0493 W/m·K, if to compare it with air – 0.026 W/m·K, then it is possible to win somewhat in the maximum heating temperature. And if to take xenon with a thermal conductivity of 0.0057 W/m·K, it will only get worse. When filled with neon, the maximum temperature became 14 °C lower. If the transducer does not provide for repair, then it is poured with a compound. In this housing, it is proposed to fill it with a mixture of a filling material and a heat-conducting powder, like a thermal paste; the essence of the development of such a material is described in [23]. Since the process of creating a new material must be accompanied by a number of tests, the thermal conductivity coefficient and other characteristics can only be determined experimentally, then let's take a known material for modeling. This is Prolimatech PK-1, has a density of 3200 kg/m<sup>3</sup>, a thermal conductivity of 10.2 W/m·K. With this cooling option, the maximum temperature decreased by 108 °C.

Efficiency of using various fillings of a sealed housing: the housing is filled with an insulating liquid – 27.5 %, filled with neon – 6.8 %, filled with a mixture of thermal paste – 53 %.

**6.3. Housing with holes.** Under proper operating conditions, ventilation openings are allowed in the housing. According to the physical phenomenon of convection flow, it is optimal to make holes on the top of the transducer so that warm air can escape to the outside.

With one hole on the side of the transducer, the temperature decreased by 10 °C, that is, by only about 5 %. It is interesting that with an increase to 8 having opened, the value of the maximum heating temperature did not change much. But when the PET is turned 90°, that is,

when the hole is on top, the efficiency of such cooling will be 13 %. And with 8 holes – 18.6 %. Such modeling in SolidWorks Flow Simulation took place by changing the direction of gravity – along the X axis.

**6.4. Changing the shape of the back plate.** Let's consider three options for changing the shape of the back plate (Fig. 3), with which it is possible to replace the classic cylindrical one in order to increase heat dissipation. The main principles: increase the surface area, but at the same time do not change the weight and height of the plate. Then the resonant frequencies will not change. The first option is radiator fins along the side wall, the next is vertical fins and cylindrical fins. The mass difference from the initial 411 g is no more than 1 % for all variants.

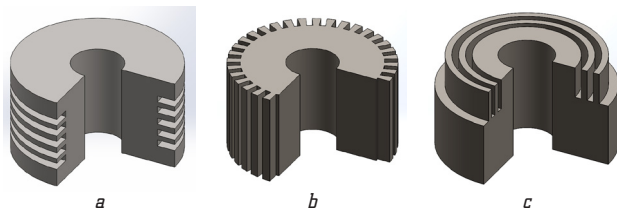

**Fig. 3.** Back plate:

*a* – with radial fins; *b* – with vertical fins; *c* – with cylindrical fins

These cooling options gave efficiencies of 7.6 %, 6.6 % and 8 %, respectively, for a closed housing filled with air.

**6.5. Heat-absorbing layer.** The addition of a heat-resistant copper element with a thickness of 2 mm, outer and inner diameters equal to the corresponding dimensions of the piezoelectric element, gave a decrease in the maximum heating temperature by 6 %, compared with a closed housing.

**6.6. Active cooling.** Active cooling involves using the energy of another appliance to reduce the heating temperature. For air purging of the PET, it is necessary that the air is dry and clean. Consider a typical situation where there is a compressor or mini-fan on top of the housing (modern fans are 2 cm<sup>2</sup> in size), and the outlet is located on the side of the housing. Air is supplied at room temperature, with a mass flow rate:  $37.92 \cdot 10^{-5}$  kg/s,  $7.58 \cdot 10^{-5}$  kg/s,  $3.792 \cdot 10^{-5}$  kg/s, which corresponds to a change in the entire volume of the housing in 1 s, 5 s and 10 s, respectively. With the help of simulation, it was found that the first option corresponds to an air speed at the entrance to the housing of 4.2 m/s, and a slow blowing – to a speed of 0.42 m/s.

Fig. 4 shows the distribution of the thermal field at fast blowing. Efficiency of using active cooling with different mass flow rates:

- when changing the entire volume of air in the housing for 1 s, the maximum heating temperature decreased by 47 %;
- when a 5-fold decrease in the blowing speed, the temperature decreased by 19 %;
- when a 10-fold decrease in the blowing speed, the temperature decreased by 11 %.

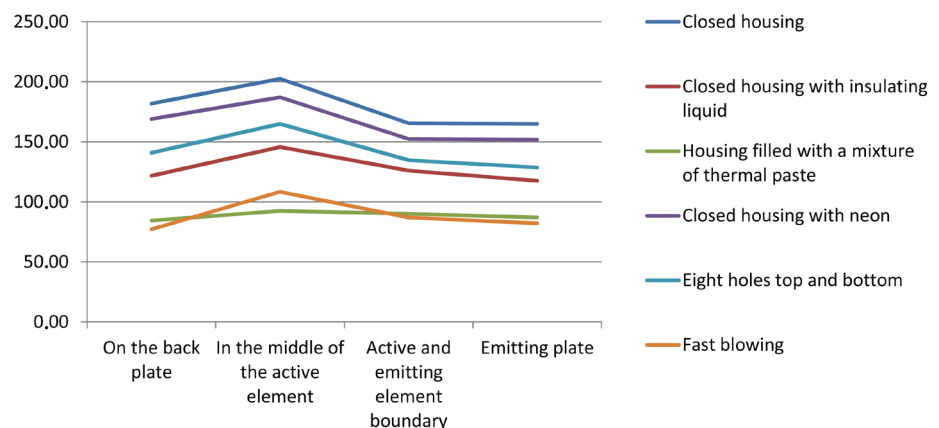

**Fig. 5.** Graph of temperature distribution in piezoceramic electroacoustic transducers for six cooling options

Let's supplement active cooling with the previous options for changing the shape of the back cover.

When using fast blowing, the cooling efficiency values are different:

- for radial radiator fins, the temperature in the active element decreased by 46 %;
- for a back plate with vertical fins by 50 %;
- for a back plate with cylindrical fins by 48 %.

With a decrease in mass flow, the shape of the back cover almost does not adhere to the cooling efficiency: the temperature decrease was 20–21 % for medium-speed blowing, and 13–14 %, respectively, for a slow one.

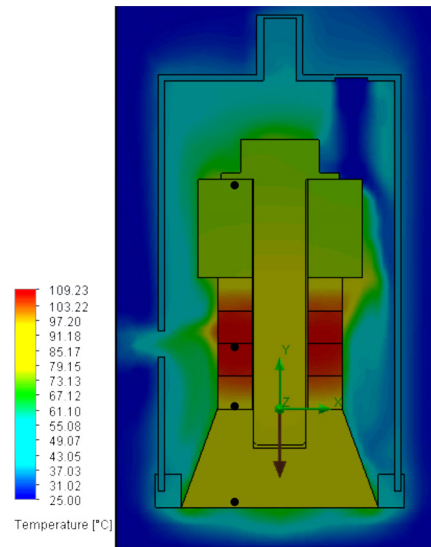

**Fig. 4.** Thermal field of piezoceramic electroacoustic transducer with active cooling

Let's show the graph of the temperature distribution (Fig. 5) over four points of the transducer (in Fig. 4 it is shown with black dots):

- 1) on the back cover;
- 2) in the middle of the active element;
- 3) at the border of the active element and the radiating plate;
- 4) on the back plate for the most efficient cooling options. Vertical axis – temperature °C.

According to the graph in Fig. 5, the uniformity of the thermal field can be determined. A sharp temperature drop has a negative effect on the adhesive layers.



## 7. SWOT analysis of research results

**Strengths.** Reducing the heating temperature of the device increases its efficiency and durability. Taking into account the efficiency and optimization of resources, the best cooling result is achieved: by filling with an insulating liquid for a sealed housing and making optimal holes for those structures where the housing can be perforated. These options are less costly. Small efficiency gives a change in the shape of the back cover, but labor costs for this method are also small.

**Weaknesses.** When the temperature of the transducer changes, its parameters change, in some housing it is necessary to use an automatic frequency control system, a device for temperature control and others, which increases the cost of the entire system.

Active cooling, that is, rapid blowing and filling of the free space with a heat-conducting mixture, give the best results in reducing the heating temperature. But for using such a mixture, the necessary preparation stage is accompanied by a number of tests that increase the manufacturing time and the cost of manufacturing the transducer. And to use a fan, or a compressor paired with a dehumidifier, additional devices are needed, which also lead to an increase in the cost of the finished device.

**Opportunities.** Taking into account the thermal fields in the PET design, the efficiency of using such transducers can be significantly improved and the time of their proper operation can be increased. Based on the research data, it is possible to significantly reduce the stage of selecting the optimal option for cooling a Langevin-type piezoceramic electroacoustic transducer.

**Threats.** The use of PET cooling methods will add one more stage during their design and complicate their production somewhat. For those transducers that do not require long-term stable operation and low-power transducers, additional cooling is not important.

## 8. Conclusions

1. The thermal field of the transducer was modeled in SolidWorks without considering the housing and with the existing housing. The presence of the housing increases the maximum heating temperature of piezoelectric ceramics by almost 1.45 times. By modeling the external problem, it was possible to find out the temperature outside the probe, it gives an important understanding of the temperature of the working environment and the housing.

2. Having analyzed the methods of reducing the heating temperature of the transducer, suitable for Langevin-type transducers, the following options were proposed:

- filling the housing cavity with electrical insulating liquid, gas, a mixture of thermal paste;
- use of holes in the housing;
- changing the shape of the back cover with radiator fins: lateral, vertical, cylindrical;
- heat-resistant layer;
- use of active air cooling at three different speeds.

3. Using modeling in SolidWorks Flow Simulation, the following results were obtained to identify the most effective cooling methods for PET, taking into account the housing. The best results of temperature reduction (53 %) and uniform temperature distribution throughout the transducer were obtained by filling the housing with a special

mixture, but this option is quite expensive and laborious. Also, quite good cooling results were shown by purging the housing with air (47 %) and filling the housing with an insulating liquid (27 %). It is possible to see that a rational arrangement of holes in the housing (18.6 %) gives better efficiency indicators than slow blowing (11 %). That is, it is necessary to make holes so that cold air has the opportunity to enter the housing and freely exit by convection flows. Changing the shape of the back plate in the presence of blowing did not significantly improve cooling efficiency. The reason for this is the inaccessibility of the air flow supplied to the most heated element – piezoelectric ceramics. After all, it is known that the heat transfer coefficient of a solid increases with an increase in the speed of movement of the environment. An increase in the outer radius of the back plate is harmful in this case.

The research results make it possible to choose the optimal option for reducing the heating temperature of the Langevin-type piezoceramic electroacoustic transducer to increase the efficiency and duration of its trouble-free operation.

## References

1. Peng, Z., Zhang, D., Zhang, X., Yao, G. (2020). Ultrasonic-assisted transducer for electrosurgical electrodes. *Procedia CIRP*, 89, 245–249. doi: <http://doi.org/10.1016/j.procir.2019.11.004>
2. Harkness, P., Cardoni, A., Russell, J., Lucas, M. (2010). Designing a Hollow Langevin Transducer for Ultrasonic Coring. *Applied Mechanics and Materials*, 24–25, 65–70. doi: <http://doi.org/10.4028/www.scientific.net/amm.24-25.65>
3. Bogush, M. V., Bogush, O. M., Pikalev, E. M. (2013). Analiz temperaturnykh napryazheniy v elementakh gidroakusticheskikh antenn. *Pribory*, 10 (160), 38–42.
4. Arata, D. (2006). *Why Ultrasonic Cleaning Systems Fail – And How to Prevent It*. Available at: <https://www.ptonline.com/articles/why-ultrasonic-cleaning-systems-fail-and-how-to-prevent-it>
5. Hmelev, G., Barsukov, V., Ilchenko, E. (2013). Study of the effect of temperature on the parameters of ultrasonic oscillatory systems. *Polzunovsky Almanac*, 1, 54–58.
6. Ilg, J., Rupitsch, S. J., Lerch, R. (2013). Impedance-Based Temperature Sensing With Piezoceramic Devices. *IEEE Sensors Journal*, 13 (6), 2442–2449. doi: <http://doi.org/10.1109/jsen.2013.2256121>
7. Rathod, V. T. (2019). A Review of Electric Impedance Matching Techniques for Piezoelectric Sensors, Actuators and Transducers. *Electronics*, 8 (2), 169. doi: <http://doi.org/10.3390/electronics8020169>
8. Panich, A. A., Karyukov, E. V., Svirskaya, S. N., Skrylev, A. V., Malykhin, A. Yu. (2012). *Vozможnost kompleksnogo issledovaniya temperaturnoy zavisimosti elektrofizicheskikh parametrov pezoektricheskogo priborostroeniya*. Rostov-na-Donu, 27–31.
9. Huang, F., Zheng, D.-Y., Hu, S.-M., Peng, G.-G. (2015). The Influence of Environment Temperature on the Degradation of Lead Zirconate Titanate Ceramic. *Proceedings of the 2015 International Conference on Material Science and Applications*. Suzhou, 3, 723–727. doi: <http://doi.org/10.2991/icmsa-15.2015.132>
10. Lee, H., Zhang, S., Bar-Cohen, Y., Sherrit, S. (2014). High Temperature, High Power Piezoelectric Composite Transducers. *Sensors*, 14 (8), 14526–14552. doi: <http://doi.org/10.3390/s140814526>
11. Liao, X., Qiu, Z., Jiang, T., Sadiq, M., Huang, Z., Demore, C., Cochran, S. (2015). Functional Piezocrystal Characterisation under Varying Conditions. *Materials*, 8 (12), 8304–8326. doi: <http://doi.org/10.3390/ma8125456>
12. Georges Sabat, R., Mukherjee, B. K., Ren, W., Yang, G. (2007). Temperature dependence of the complete material coefficients matrix of soft and hard doped piezoelectric lead zirconate titanate ceramics. *Journal of Applied Physics*, 101 (6), 064111. doi: <http://doi.org/10.1063/1.2560441>
13. Cao, H. C., Evans, A. G. (1992). Non-Linear Constitutive Properties of Piezoelectric Ceramics. *MRS Proceedings*, 276, 39–49. doi: <http://doi.org/10.1557/proc-276-39>

14. Li, T., Chen, Y. H., Ma, J. (2007). Frequency dependence of piezoelectric vibration velocity. *Sensors and Actuators A: Physical*, 138 (2), 404–410. doi: <http://doi.org/10.1016/j.sna.2007.05.024>
15. Uchino, K. (2017). *Manufacturing Methods for Piezoelectric Ceramic Materials. Advanced Piezoelectric Materials*. Elsevier, 385–421. doi: <http://doi.org/10.1016/b978-0-08-102135-4.00010-2>
16. Lu, X., Hu, J., Peng, H., Wang, Y. (2017). A new topological structure for the Langevin-type ultrasonic transducer. *Ultrasonics*, 75, 1–8. doi: <http://doi.org/10.1016/j.ultras.2016.11.008>
17. Karafi, M. R., Khorasani, F. (2019). Evaluation of mechanical and electric power losses in a typical piezoelectric ultrasonic transducer. *Sensors and Actuators A: Physical*, 288, 156–164. doi: <http://doi.org/10.1016/j.sna.2018.12.044>
18. Vasiljev, P., Mazeika, D., Borodinas, S. (2012). Minimizing heat generation in a piezoelectric Langevin transducer. *IEEE International Ultrasonics Symposium*, 2714–2717. doi: <http://doi.org/10.1109/ultsym.2012.0680>
19. Butler, J. L., Butler, A. L., Butler, S. C. (2012). Thermal model for piezoelectric transducers (L). *The Journal of the Acoustical Society of America*, 132 (4), 2161–2164. doi: <http://doi.org/10.1121/1.4748583>
20. Dong, X., Yuan, T., Hu, M., Shekhani, H., Maida, Y., Tou, T., Uchino, K. (2016). Driving frequency optimization of a piezoelectric transducer and the power supply development. *Review of Scientific Instruments*, 87 (10), 105003. doi: <http://doi.org/10.1063/1.4963920>
21. Su, Y. H., Liu, Y. P., Vasic, D., Costa, F., Wu, W. J., Lee, C. K. (2013). Power enhancement of piezoelectric transformer by adding thermal dissipation layers. *ICAST 2013 – 24th International Conference on Adaptive Structures and Technologies*, 239–249.
22. Robert, A. J., Sheehan, J. F. (2002). Pat. No. 6434244 B1 US. *Electroacoustic Converter*. MPK: B06B1/0618. published: 13.08.2002.
23. Peshkovsky, S., Peshkovsky, L. (2015). Pat. No. 9142751 B2 US. *Efficient cooling of piezoelectric transducers*. MPK: H01L41/053. published: 22.09.2015.
24. Hielscher, H. (2011). Pat. No. 8004158 B2 US. *Method And Device For Cooling Ultrasonic Transducers*. MPK: G10K11/004. published: 23.08.2011.
25. Nilsson, B., Dahlberg, H. (1998). Pat. No. 5955823 US. *High power ultrasonic transducer*.
26. Vjuginova, A. A. (2019). Multifrequency Langevin-Type Ultrasonic Transducer. *Russian Journal of Nondestructive Testing*, 55 (4), 249–254. doi: <http://doi.org/10.1134/s1061830919040132>
27. Perchevska, L. V., Drozdenko, O. I., Drozdenko, K. S., Leiko, O. H. (2019). Providing of Rod Piezoceramic Electroacoustic Transducers Thermal Mode Operation. *Microsystems, Electronics and Acoustics*, 24 (5), 56–63. doi: <http://doi.org/10.20535/2523-4455.2019.24.5.190452>
28. Drozdenko, O., Dozdenko, K., Leiko, O., Perchevska, L. (2020). The Thermal Fields Analysis of Sealed Cylindrical Piezoceramic Electroacoustic Transducers Compensated Construction. *2020 IEEE 40th International Conference on Electronics and Nanotechnology (ELNANO)*, 815–819. doi: <http://doi.org/10.1109/elnano50318.2020.9088757>

---

**Liudmyla Perchevska**, Postgraduate Student, Department of Acoustic and Multimedia Electronic Systems, National Technical University of Ukraine «Igor Sikorsky Kyiv Polytechnic Institute», Kyiv, Ukraine, e-mail: [4888814@gmail.com](mailto:4888814@gmail.com), ORCID: <https://orcid.org/0000-0003-0117-5163>

**Oleksandr Drozdenko**, PhD, Associate Professor, Department of Acoustic and Multimedia Electronic Systems, National Technical University of Ukraine «Igor Sikorsky Kyiv Polytechnic Institute», Kyiv, Ukraine, e-mail: [doi70219-ames@lkl.kpi.ua](mailto:doi70219-ames@lkl.kpi.ua), ORCID: <https://orcid.org/0000-0001-6647-1428>

**Kateryna Drozdenko**, PhD, Department of Acoustic and Multimedia Electronic Systems, National Technical University of Ukraine «Igor Sikorsky Kyiv Polytechnic Institute», Kyiv, Ukraine, e-mail: [dks75537-ames@lkl.kpi.ua](mailto:dks75537-ames@lkl.kpi.ua), ORCID: <https://orcid.org/0000-0002-7653-600X>

**Oleksandr Leiko**, Doctor of Technical Sciences, Professor, Department of Acoustic and Multimedia Electronic Systems, National Technical University of Ukraine «Igor Sikorsky Kyiv Polytechnic Institute», Kyiv, Ukraine, e-mail: [log40413-ames@lkl.kpi.ua](mailto:log40413-ames@lkl.kpi.ua), ORCID: <https://orcid.org/0000-0002-5588-6449>