



**Valentyna Halushko,
Alexander Meneilyk,
Anatolii Petrovskiy,
Denys Uvarov,
Anastasiia Uvarova**

DEVELOPMENT OF TECHNOLOGY OF MIXTURE APPLICATION ON VERTICAL SURFACE

The object of research is the development of applying a consistency to a vertical surface using an automated device. One of the most problematic places is the poor quality of work at height and the danger associated with the life of workers. Currently, there is only a manual and semi-mechanized method of applying the mixture to a vertical surface. When applying plaster to a vertical surface inside a building, some countries use a plastering robot. In this case, the work is done with high quality and is serviced by two workers. Therefore, when studying this issue, the authors decided to develop a device with which it is possible to perform work on applying to a vertical surface from the outside of the building with high quality.

In the course of the study, technological maps were used, on the basis of which estimates were developed, which showed that the introduction of new technologies makes it possible to obtain up to 20 % cost savings on works, equipment and mechanisms. An economic effect was obtained from the developed technology. This is due to the fact that the proposed technology makes it possible to reduce the cost of work using the developed equipment, since the equipment serves 3 workers, namely 1 operator and 2 workers servicing this equipment. The proposed equipment has a number of features that make it possible to additionally mix the mixture at the outlet, edit the supply of the mixture, apply the required thickness evenly, in particular, control the quality of work. This makes it possible to choose the inclination angle, the thickness of the mixture and obtain indicators of the strength of the mixture and the number of losses. Compared to similar known methods, the mixture is fed automatically, which provides advantages such as quality control, safety precautions and reduces the risk of loss of life.

Keywords: mixture application equipment, vertical surface, nozzle angle, layer thickness, safety precautions.

Received date: 01.03.2022

Accepted date: 18.04.2022

Published date: 30.04.2022

© The Author(s) 2022

This is an open access article
under the Creative Commons CC BY license

How to cite

Halushko, V., Meneilyk, A., Petrovskiy, A., Uvarov, D., Uvarova, A. (2022). Development of technology of mixture application on vertical surface. *Technology Audit and Production Reserves*, 2 (1 (64)), 6–10. doi: <http://doi.org/10.15587/2706-5448.2022.257050>

1. Introduction

When applying mixtures to a vertical surface, it is not always advisable to use stationary equipment from an economic point of view or because of the complexity of the technology.

First of all, this is due to the danger when working at height, poor-quality application, cost overruns of materials and funds. For a small volume in small areas, assembly climbers are used (Fig. 1).

In this case, it is necessary to control not only the performance of high-quality work, but also compliance with safety regulations [1, 2]. In some countries of the world, a plastering robot is used for finishing works in new construction [3–5]. Therefore, in some cases, when applying mixtures to a vertical surface, it will be more efficient to use other types of equipment.

Therefore, it is relevant to develop a technological process for applying to a vertical surface using equipment that will allow performing work efficiently and reducing the risk to workers.



Fig. 1. Photo-fragment of application of the mixture: *a* – equipment adjustment; *b* – equipment cleaning; *c* – process of applying the mixture to a vertical surface

Thus, *the object of research* is the technology of applying a mixture to a vertical surface using an automated device. *The aim of research* is to develop a technology for applying a mixture to a vertical surface using the mechanism proposed in the work, which will allow performing work at height with high quality and without human casualties.

2. Research methodology

The authors of [6, 7] worked in this direction. 3D printers have been developed for application on a vertical surface [8–10]. But their use is limited. After analyzing the existing information [1, 11, 12], the authors tried to develop a device that will help to perform a set of works (cleaning, priming and applying the mixture) and will reduce the duration, improve the quality of the work, and reduce the risks of workers at height.

The authors have developed the device «Portal». It includes two blocks. At the same time, the first block is the main one, which provides autonomous operation; the second block is a semi-block that can be extended into the first block and cannot work autonomously. There may be several such semi-blocks, depending on the length of the object (Fig. 2).

The portal is an autonomous frame and semi-frame. It consists of a longitudinal deflection (portal), rack. Racks relative to the vertical are installed with an inclination to provide a more stable state, forming an anchor element. Racks are connected by a shelf. The shelf provides a rigid connection of two oppositely located end anchor elements, respectively, of the bottom; top; semi-portal.

For free movement around the place of work, the «Portal» has wheels in the form of articulated joints and laying on the floor. To reduce the load, the rails can be laid on sleepers.

In the upper part of the «Portal» at specially defined points, plates are rigidly welded, on which portable screw jacks are installed. The joint work of the main block and the semi-block is provided with a swivel connection using connecting strips.

The «Portal» is equipped with a movable graduated element in the form of a toothed hemisphere, on running carts, on which, both the first block and the second block, devices for intensifying the spraying of the fluid mixture can be installed.

In connection with the work that can be performed at different heights, the portal is made in the form of stackable various constituent structural elements.

Holding on the weight of the devices for spraying the mixture on a vertical surface is carried out with the help of cables.

Rigging work is carried out with the help of a winch, with stops, including a ratchet wheel, a shaft, a pawl, an axle, a spring, various types of grip, etc. These equipments do not prevent the lifting of the load, but exclude the possibility of its spontaneous descent under its own weight.

For the manufacture of structures, steel alloys are used in accordance with the current standards for specific elements, depending on the operating conditions.

The portal works as follows. To perform work at height, let's suggest using a device for intensifying the spraying of the mixture, with which it is possible to clean, prime and apply the mixture.

The portal is mounted on the vertical surface of the building as follows. Directions are set on the roof and along the building in which the portal will move. Next, a portal is mounted – a frame, to which a device is attached to the cables for cleaning, priming and applying the mixture. On the top of the frame of the portal there are fasteners with which the nozzle can move from top to bottom without changing the path.

After connecting the system, perform the following work at height. Namely: cleaning the surface, priming and applying the mixture. Fig. 2, *b* shows section 1–1 (scheme of equipment operation).

To perform work (Fig. 3), the required mixture is fed through a branch pipe having a hinged-layer or rigid connection with a hollow shaft and then into the housing, on which a screw of direct and reverse action is freely mounted. When connected, they begin to rotate in different directions, and special spacer clamps ensure their design position, while the hollow shaft rests on the plugs, which are boundary housings.

The mixture gradually moves to the humidification zone, where water is supplied through the holes located on a certain section of the shaft (if necessary). Further, under the action of acceleration, the mixture moves to the reverse screw, which is fed to the corresponding part of the building. In order to regulate the amount of the supplied mixture, the nozzle has a set of replaceable valves and, accordingly, increase or decrease the opening and the amount of the supplied mixture.

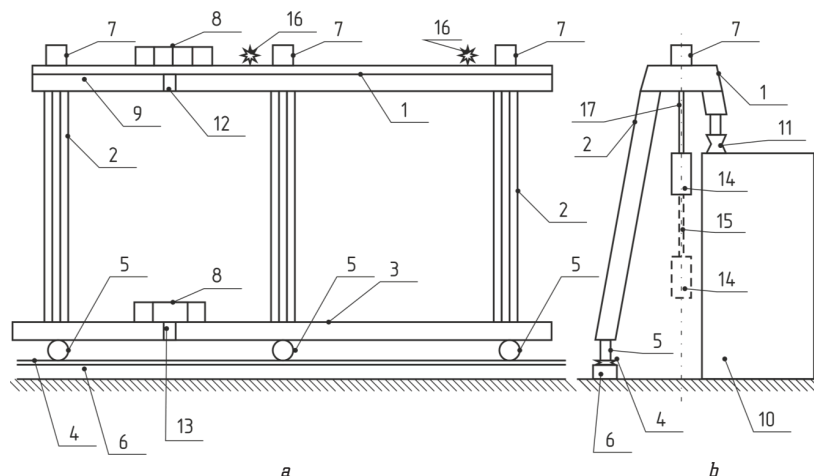

Fig. 2. Device for performing work on applying the mixture to a vertical surface: *a* – scheme of the «Portal»; *b* – section 1–1 (scheme of equipment operation); 1 – portal; 2 – rack; 3 – connecting shelf; 4 – rail; 5 – wheel; 6 – sleepers; 7 – jacks; 8 – connecting strip; 9 – semi-portal; 10 – building; 11 – grips to hold the device; 12 – swivel portal; 13 – hinged connection of the connecting strip; 14 – device for intensifying the spraying of a fluid mixture; 15 – moving the device vertically (from top to bottom, and vice versa); 16 – running carts; 17 – winch

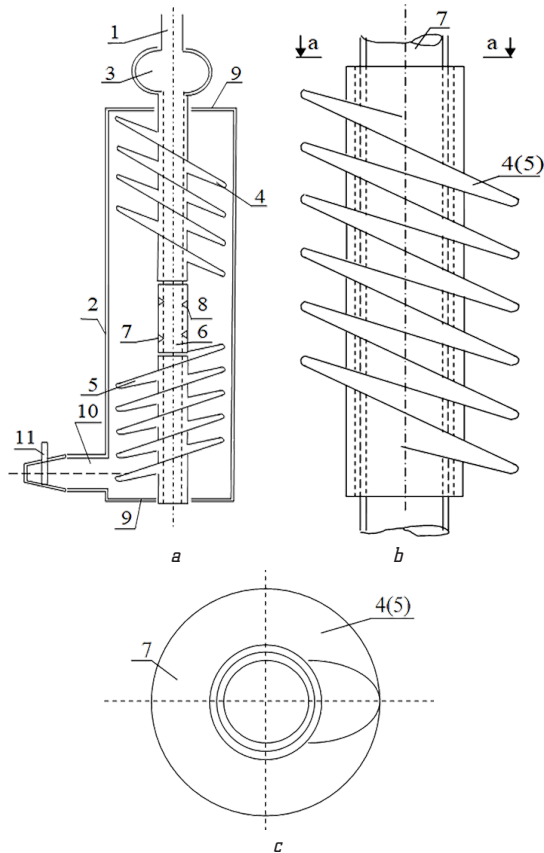

Fig. 3. A device for intensifying the spraying of a fluid mixture: *a* – general view; *b* – internal organ; *c* – top view; 1 – mixture supply pipe; 2 – body; 3 – hinged-layer connection; 4 – screw direct action; 5 – reverse screw; 6 – spacer latch; 7 – hollow shaft; 8 – through holes; 9 – plug; 10 – nozzle; 11 – damper

At the same time, to increase the feed rate of the corresponding mixture, the nozzle is installed perpendicular to the axis of the hollow shaft.

These technical features ensure the use of the proposed technical solution in construction based on the following advantages:

- the quality of intensification of the spray mixture is improved;
- it becomes possible to adjust the amount, and therefore the speed of the mixture, by using one of the dampers;
- the serviceability is increased, ensuring that such a «Device...» meets the criterion «Industrial suitability»;
- improving the quality of work at height.

New in the development is the use of mixing elements, freely rotating in different directions at the same time, and the placement of the nozzle perpendicular to the axis of the hollow shaft.

3. Research results and discussion

When performing laboratory studies, the following results were obtained: the distance from the nozzle to the vertical surface was from 0.8 to 1.2 m, while the amount of rebound ranged from 17.2 to 16.4 %.

Based on the results obtained, a graph of the strength dependences of the mixture and the amount of losses on the inclination angle of the nozzle to the surface was plotted (Fig. 4).

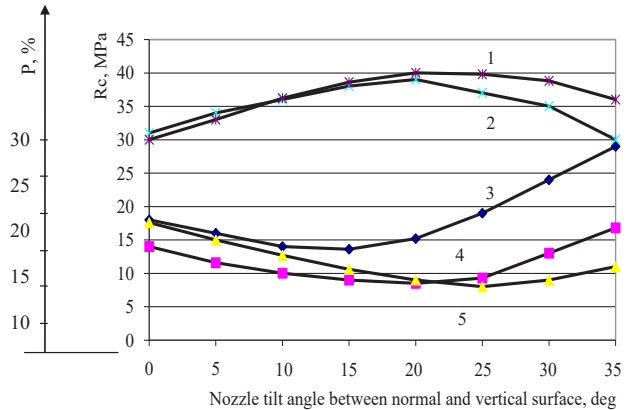

Fig. 4. Graph of dependences of the strength of the mixture and the amount of losses on the inclination angle of the nozzle to the vertical surface: 1, 2 – ultimate compressive strength, R_c , MPa; 3, 4, 5 – amount of losses, P , % (3 – layer strip thickness 30 μm , 1, 4 – mixture layer strip thickness 50 μm , 2, 5 – layer strip thickness 80 μm)

Analysis of Fig. 4 showed that the strength of the mixture and the amount of losses depend on the inclination angle of the nozzle and the thickness of the laid layer. With a mixture layer thickness of 50 μm and an inclination angle of 150 to 250, the amount of losses reaches a minimum level of 8.5–9.5 %, and the ultimate strength is 37–39 MPa. In the engineering sense, such an inclination angle is optimal in terms of the criteria for assessing the strength of the mixture with the surface and the amount of mixture loss.

When choosing the technology for applying the mixture to a vertical surface, the following schemes were considered: perpendicular-rectilinear, perpendicular-circular, and inclined-rectilinear (Fig. 5).

For these schemes, the optimal combinations of applying the concrete mix were chosen: with a perpendicular-rectilinear application, the nozzle inclination angle was chosen to be 90°; the layer thickness was 30 μm . With circular rotation, at least two coats must be applied. This is due to the perpendicular-circular movement, since the layers are laid unevenly on the surface. Therefore, by applying two layers, a uniform application thickness of 50 μm can be achieved. In the case of rectilinear oblique movement, the optimal inclination angle is 20° and the thickness is 80 μm . In this case, the amount of losses is minimal; the particles of the mixture penetrate deep over the surface, so the strength is maximum.

The calculation is made for the following schemes:

a) formation of a uniform layer of the mixture along the height with circular movements of the nozzle perpendicular to the surface:

$$V_1 = V \cdot \cos\varphi,$$

where φ – the nozzle inclination angle, $\varphi=0-45^\circ$; V – the speed of the mixture, m/s;

b) formation of a layer of the cross section of a single strip, approaching an isosceles triangle with a rounded top. The velocity vector V_1 , which determines the depth of penetration of particles into the formed layer, is equal to:

$$V_1 = V \cdot \cos(\alpha + \gamma),$$

where β – the angle between the velocity vector V and V_1 ; α – the strip inclination angle; γ – the incidence angle of the peripheral particle;

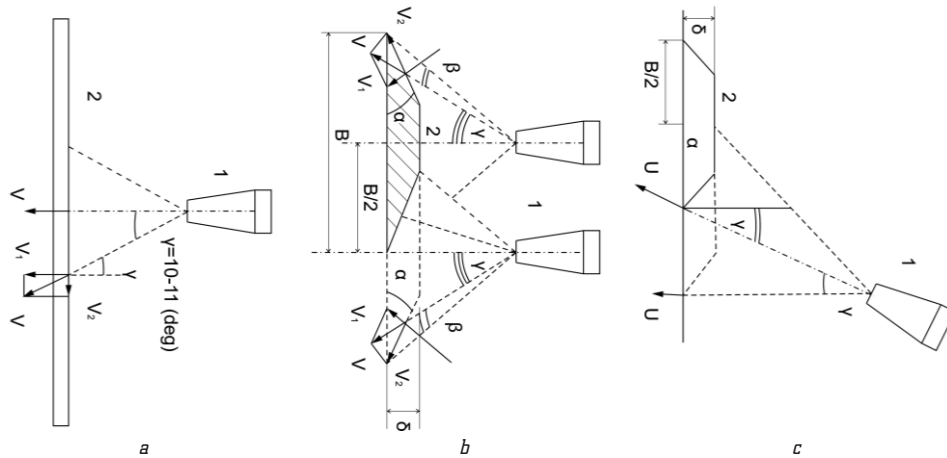

Fig. 5. Schemes for the formation of a separate strip of a layer of material: *a* – perpendicular-rectilinear; *b* – perpendicular-circular; *c* – obliquely rectilinear; 1 – nozzle; 2 – molding layer; *V* – the particle velocity vector; *V*₁ and *V*₂ – the normal and tangential components of the vector; *B*, δ – the width and height of the strip; α – the slope angle of the strip; β – the angle of meeting of the part with the slope of the strip; γ – the angle of incidence of mixture parts

c) the formation of a uniform paint layer along the height with circular movements of the nozzle perpendicular to the vertical surface:

$$\text{tg}\varphi = (2 \cdot \delta) / B,$$

where δ – the thickness of the material layer, mm; φ – the inclination angle of the nozzle from the vertical; *B* – the width of a single strip of material.

Table 1 shows the optimal combinations of the layer thickness and the inclination angle of the nozzle axis to the surface and considers the technological schemes of deposition.

Optimal combinations

Table 1

No.	Technological schemes	Layer thickness, mm	Inclination angle of the nozzle from the normal to the surface of the structure, degrees
1	perpendicular-rectilinear	30	90
2	perpendicular-circular	50	90
3	oblique-rectilinear	80	20

An analysis of different methods showed that the most acceptable organization of the technological process of applying a mixture to a vertical surface is the method of supply using the proposed device [13–15]. This allows increasing labor productivity and performing work efficiently, since the work is performed by suspended equipment, and it controls the work of the operator.

The use of new types of equipment has limitations in the use of the height of the structure, terrain, support base and the possibility of support from above the structure. To work without relying on the top of the structure, it is necessary to make U-shaped portals with double support on the ground. The use of this technology requires additional justification and research.

4. Conclusions

In the course of the study, an economic effect was obtained from the developed technology. This is due to the

fact that the proposed technology makes it possible to reduce the cost of work using the equipment developed by the authors, since the equipment serves 3 workers, namely 1 operator and 2 workers servicing this equipment. The proposed equipment has a number of features that make it possible to additionally mix the mixture at the outlet, edit the supply of the mixture, apply the required thickness evenly, in particular, control the quality of work. This makes it possible to choose the inclination angle, the thickness of the mixture and obtain indicators of the strength of the mixture and the number of losses. Compared to similar known methods, the mixture is fed automatically, which provides advantages such as quality control, safety precautions and reduces the risk of loss of life.

References

- Chernenko, V. K., Yarmolenko, M. H., Batura, H. M. et. al. (2002). *Tekhnolohiia budivelnoho vyrobnytstva*. Kyiv: Vyscha shkola, 430.
- Barabash, I. V. (2002). *Mekhanokhimichna aktyvatsiia mineralnykh v'iazhuchykh rechovyn*. Odesa: Astroprint, 100.
- Warszawski, A. (1984). Application of Robotics to Building Construction. *Proceedings of the 1st International Symposium on Automation and Robotics in Construction (ISARC)*. Pittsburgh: The International Association for Automation and Robotics in Construction, 33–40. doi: <http://doi.org/10.22260/isarc1984/0003>
- Precision Construction Robot Hadrian X* (2021). Fastbrick Australia. Available at: <https://www.fbr.com.au/view/hadrian-x>
- RoboPlaster*. Available at: <https://roboplaster-1.pulscen.ua/about>
- Tateyama, K., Ishii, K., Inoue, F. (2020). Front matter and table of contents. *Proceedings of the 37th International Symposium on Automation and Robotics in Construction (ISARC)*. Kitakyushu: The International Association for Automation and Robotics in Construction. doi: <http://doi.org/10.22260/isarc2020/0002>
- Kayser, M., Cai, L., Falcone, S., Bader, C., Inglessis, N., Darweesh, B., Oxman, N. (2018). Design of a multi-agent, fiber composite digital fabrication system. *Science Robotics*, 3 (22). doi: <http://doi.org/10.1126/scirobotics.aau5630>
- Keating, S. (2016). Digital Construction Platform. *MIT Media Lab*. Available at: <https://www.media.mit.edu/projects/digital-construction-platform-v-2/overview/>
- MX3D BRIDGE* (2019). Available at: <https://mx3d.com/projects/mx3d-bridge>
- Guaman-Rivera, R., Martinez-Rocamora, A., Garcia-Alvarado, R., Munoz-Sanguinetti, C., Gonzalez-Bohme, L. F., Auat-Cheein, F. (2022). Recent Developments and Challenges of 3D-Printed Construction: A Review of Research Fronts. *Buildings*, 12 (2), 229. doi: <https://doi.org/10.3390/buildings12020229>

11. Ning, X., Liu, T., Wu, C., Wang, C. (Ed.) (2021). 3D Printing in Construction: Current Status, Implementation Hindrances, and Development Agenda. *Advances in Civil Engineering* 2021, 1–12. doi: <https://doi.org/10.1155/2021/6665333>
12. Malewar, A. (2017). *Meet SAM: a Construction Robot That Works 500 % Faster Than Humans*. Available at: <https://www.techexplorist.com/meet-sam-construction-robot-works-500-faster-humans/5357/>
13. Halushko, V., Meneiliuk, A., Kyrlyuk, S. (2021). Determination of cracking causes in building structural elements. *Sustainable Development of Industrial Region*, 258. doi: <http://doi.org/10.1051/e3sconf/202125809038>
14. Halushko, V. O. (2009). Pat. No. 45279 UA. *Portal dlia vykonannia remontno-vidnovliwalnykh robot*. MPK: (2009) E04G 23/00, E04G 21/00, B66C 17/00. declared: 21.05.2007; published: 10.11.2009, Bul. No. 21, 10.
15. Meneiliuk, O. I., Halushko, V. A., Halushko, O. M., Donchenko, M. M., Pidoima, A. S., Baliuk, S. V., Uvarov, D. Yu. (2015). Pat. No. 101756 UA. *Prystrii dlia intensyfikatsii napryskuvannia tekuchoi sumishi*. MPK: E04F 21/02 (2006.01) declared: 20.04.2015; published: 25.09.2015, Bul. No. 18, 6.

✉ **Valentyna Halushko**, Doctor of Technical Sciences, Associate Professor, Department of Technologies of Building Production, Odessa

State Academy of Civil Engineering and Architecture, Odessa, Ukraine, e-mail: dtn.gva@gmail.com, ORCID: <https://orcid.org/0000-0001-5744-0486>

Alexander Meneilyk, Doctor of Technical Sciences, Professor, Head of Department of Technologies of Building Production, Odessa State Academy of Civil Engineering and Architecture, Odessa, Ukraine, ORCID: <https://orcid.org/0000-0002-1007-309X>

Anatolii Petrovskiy, Doctor of Technical Sciences, Professor, Department of Technologies of Building Production, Odessa State Academy of Civil Engineering and Architecture, Odessa, Ukraine, ORCID: <https://orcid.org/0000-0002-9818-149X>

Denys Uvarov, Postgraduate Student, Department of Technologies of Building Production, Odessa State Academy of Civil Engineering and Architecture, Odessa, Ukraine, ORCID: <https://orcid.org/0000-1000-2135-9113-42X>

Anastasiia Uvarova, Khortytsia National Training and Rehabilitation Academy, Zaporozhye, Ukraine, ORCID: <https://orcid.org/0000-0002-1416-7181>

✉ Corresponding author