

Ihor Buchma,
Mykhailo Voichenko

OVERVIEW OF METHODS AND MEANS OF IMPLEMENTATION OF INFORMATION AND MEASURING COMPONENTS CYBER-PHYSICAL SYSTEMS FOR ELECTROMAGNETIC PROBING

The object of research is cyber-physical systems for the study of inhomogeneous environments, in particular, such as land and water depths, in order to find in them the leading bodies. One of the most problematic places in the creation of such systems is a highly sensitive meter of small phase shifts with a low sensitivity threshold.

During the study, a review of methods for achieving a low threshold of sensitivity to phase shift. The main one is the method of converting the phase shift into the amplitude modulation coefficient. The implementation of the method is based on the sum-difference transformation with the preliminary introduction of the quadrature phase shift between the signals. The results concerning the methods of solving the following problems are obtained:

- increasing the temperature stability of the quadrature phase shifter;
- reducing the non-identity of the transmission coefficients of the sumo-difference scheme channels;
- allocation of the amplitude of the amplitude-phase-modulated signal at low ratios of the frequencies of the input signals and switching.

The first problem is partially solved by dividing the quadrature phase shifter into two equal halves, placed in different channels, with approximately the same phase temperature coefficients. The second problem is also solved by manual calibration before measurement. The most difficult task is to extract the bypass from the amplitude-phase-modulated signal, in which the carrier frequency is only several times greater than the bypass. The difficulty is that the detection produces combinational frequencies due to phase modulation. Therefore, it is difficult to separate them. Several methods of allocating the bypass, if the frequency of the input signals is fixed, are considered. This allows to get the sensitivity threshold ($1 \cdot 10^{-4} \div 3 \cdot 10^{-5}$) of advice. Reducing the operating frequency of the signals increases the depth of research, but increases the impact of flicker noise. The minimum frequency is 10 Hz. Therefore, these methods are not suitable for frequencies of Hz units. Methods to reduce the impact of flicker noise will be considered in another paper.

Keywords: eddy current method, phase shift measurement, harmonic signal, low frequencies, threshold sensitivity.

Received date: 27.04.2022

Accepted date: 24.06.2022

Published date: 30.06.2022

© The Author(s) 2022

This is an open access article
under the Creative Commons CC BY license

How to cite

Buchma, I., Voichenko, M. (2022). Overview of methods and means of implementation of information and measuring components cyber-physical systems for electromagnetic probing. *Technology Audit and Production Reserves*, 3 (2 (65)), 36–40. doi: <http://doi.org/10.15587/2706-5448.2022.260245>

1. Introduction

Cyber-Physical Systems (CPSs) are physically multi-component and software multi-level systems capable of making decisions and operating independently. CPS combines calculations, physical processes and a network, acting on data received from the environment and managing processes [1]. In CPS, phase measurement methods have acquired the most diverse purpose of wide application. This applies to systems in industries such as electromagnetic sounding of inhomogeneous media, radar, radio navigation, aviation and space technology, geodesy, mechanical engineering, non-destructive testing, experimental physics, and radio physics [1]. The development of highly sensitive systems for measuring phase characteristics has a significant impact on

the state of these industries [2]. A review and generalization of existing methods and means for measuring the phase characteristics of low-frequency harmonic signals makes it possible to reveal their potential. For example, to establish directions for their development and improvement to improve the characteristics of known systems and create new CPS to solve new problems [2–4].

Thus, electromagnetic sounding is used for accurate detection of internal structural defects in construction, mechanical engineering, in quality control of the road surface, to search for underground archaeological sites, etc. Vortex systems at low frequencies require high sensitivity to small phase shifts caused by geological objects and other leading bodies [3–5].

Therefore, the work is relevant, which can lead to an increase in the sensitivity of technical means for measuring

phase shifts, improve the technical characteristics of the CPS. For example, to increase the depth of electrical exploration of deposits of polymetallic and iron ores, as well as to increase the depth of search for leading bodies in the ground and water [5].

Thus, *the object of study* is the CPS for studying inhomogeneous media, in particular, such as terrestrial and water depths, in order to search for leading bodies in them. *The aim of the work* is to review the implementation of highly sensitive systems for measuring the phase characteristics of low-frequency harmonic signals based on the sum-difference method, the main approaches used in the implementation of their nodes, and to determine possible development directions.

2. Research methodology

The existing methods for measuring phase landslides can be divided into methods of compensation and direct conversion. Compensation methods are based on the classical structures of balanced conversion measuring instruments based on sequential and bitwise balancing. The disadvantages of the methods are low performance and complexity of implementation. Therefore, they are mainly used in metrological means. Direct conversion methods can be divided into methods with the transformation «phase shift – voltage – digital code», «phase shift – time intervals – digital code», as well as correlation and orthogonal methods. The shortcomings of methods with measurement for an integer number of periods include the need to perform arithmetic operations and significant errors at low frequencies [6].

The correlation method is based on the conversion of input signals by forming devices into rectangular pulses.

The disadvantage of the method is associated with the appearance of significant random errors in the measurement of noisy signals. The second disadvantage is the significant dependence of impressions on the level of non-linear signal distortions. Also, a significant drawback of the method is the non-linear nature of the scale [6–8].

The orthogonal method consists in the fact that for its implementation, the multiplication of signals in analog form is used [7]. The block diagram of such a phase meter, which implements the orthogonal method (Fig. 1), includes:

- orthogonal signal generator (OSG);
- two correlators 1 and 2, which determine the correlation integrals according to formula (1), consisting of a multiplier (X1, X2) and an integrator (Int1 and Int2);
- phase shift calculator (PSC), which determines the phase shift according to formula (2):

$$\begin{aligned}
 a_c &= \int_0^t S(t)U_m \cos(\omega_0 t) dt; \\
 a_s &= \int_0^t S(t)U_m \sin(\omega_0 t) dt,
 \end{aligned}
 \tag{1}$$

where $S(t)$ – noisy harmonic signal; $U_m \cos(\omega_0 t)$ – generator reference signal; $U_m \sin(\omega_0 t)$ – orthogonal generator signal.

$$\varphi = \arctg\left(\frac{a_c}{a_s}\right).
 \tag{2}$$

The main disadvantage of the measurement method is large instrumental errors, the need for multiple analog-to-digital conversion (ADC) of signals and the multiplication

of ADC results over a period. This leads to the limitation of operating frequencies from above, which is associated with the finite time of execution of operations in the ADC and multipliers [7, 8].

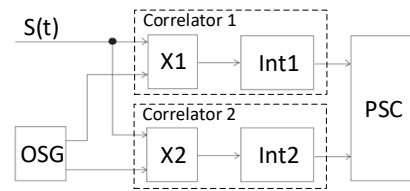

Fig. 1. Structural diagram of the phase meter implemented by the orthogonal method

To measure small phase shifts between harmonic signals at low frequencies, a sum-difference transformation is used with a preliminary input between quadrature phase shift signals. In this case, the phase shift between the signals is determined due to the ratio of the difference in the amplitudes of the total and difference signals to their sum [9]. Such a sum-difference transformation ensures high sensitivity. To reduce the measurement error of the amplitude of the signals, it is necessary to pre-align. The accuracy and stability of the introduced quadrature phase shift is also important. These operations are performed during calibration. The implementation of the sum-difference method provides good results [10]. The method is considered the most sensitive, and therefore the most suitable for measuring small phase shifts between harmonic signals.

3. Research results and discussion

As already mentioned, the sum-difference method is one of the most sensitive to changes in the phase shifts of harmonic low-frequency signals. The method is based on the transformation of the phase difference into the difference between the amplitudes of the total and difference signals U_c and U_p (Fig. 2), pre-equalized in amplitude and shifted in phase by 90 degrees, that is, by $\pi/2$ [11].

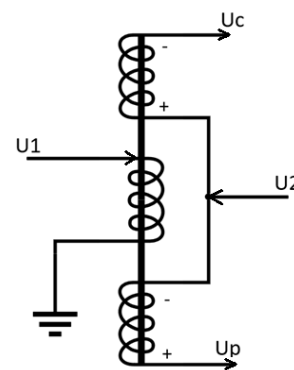

Fig. 2. Transformer circuit

Let’s consider the principles of operation and implementation of schemes for the sum-difference conversion of low-frequency harmonic signals and compare them in terms of conversion accuracy.

The vector diagram reflecting the principle of the sum-difference transformation is shown in Fig. 3.

Here, when measuring small phase shifts between two harmonic signals, their amplitudes are equalized, they are

shifted in phase by 90 degrees by a quadrature phase shifter. Next, the amplitudes of the total and difference signals are measured. Then the difference and the sum of these amplitudes are calculated, and the phase shift is determined from the ratio of the amplitude difference to the sum of the amplitudes according to the formula [11]:

$$\varphi_x = \frac{U_c - U_p}{U_c + U_p} \quad (3)$$

With this approach to measuring the phase shift, it is necessary that the stability of the introduced quadrature phase shift be very high, since the deviation from the quadrature will be perceived as a change in the measured phase shift. Therefore, it is important to first take appropriate measures to stabilize this bias.

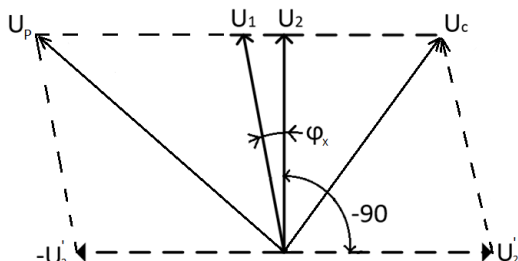

Fig. 3. Vector diagram of the sum-difference transformation

One of these measures is the division of the introduced total quadrature phase shift into two equal halves of $\pi/4$, but this shift must be in different directions, one with a + sign and the other with a - sign. So that the introduced total phase shift is $\pi/2$.

Another important condition must be that these $\pi/4$ phase shifters must be made of the same and stable elements. The simplest and most stable such phase shifters can be passive RC and CR links, in which the modules of the active resistance of the resistor R and the reactance of the capacitor C are equal to each other. With the help of a replaceable resistor, they can be adjusted.

This approach significantly reduces the influence of temperature and time on the introduced total quadrature phase shifter, the phase shift $\pi/2$. A quadrature phase shifter made of identical passive RC and CR units, which shifts one signal by $+\pi/4$, respectively, and the second signal by $-\pi/4$, will increase the stability of the introduced quadrature phase shift. This is because resistors and capacitors, despite changes in ambient temperature, are positioned so that they are always at the same temperature. Therefore, an increase in the phase shift in one channel will be compensated by a similar decrease in the phase shift in the other channel. And the overall quadrature phase shift will be much more stable [11].

To implement the sum-difference transformation, two main schemes are used. Transformer circuit (Fig. 2) or electronic circuit (Fig. 4). In the transformer circuit, the transformer has three identical beams: one primary and two secondary. The initial navoi include sequentially opposite. The first signal U_1 is sent to the initial beam, and the second signal U_2 is sent to the connection point of the original beams. The total and difference signal is taken from the free leads of the initial beams.

The transformer circuit is used less frequently due to the complexity of implementation, which is due to the difficulties in making the transformer windings symmetrical. They should be the same, but in practice this is difficult to achieve.

Therefore, a circuit on electronic analog components is more often used (Fig. 4) [12].

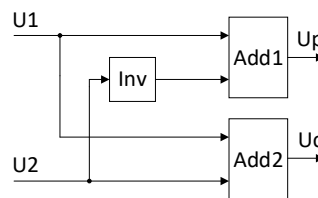

Fig. 4. Summation-difference scheme on electronic analog components

According to the diagram in Fig. 4 signal U_2 is inverted by inverter *Inv.* and is applied to the signal U_1 by the adder *Add1*, at the output of which let's obtain a signal whose amplitude is the amplitude U_p . The adder *Add2* sums both signals U_1 and U_2 and at its output there is a signal whose amplitude is U_c .

Further, in order to determine the phase shift between two signals, it is necessary to calculate the difference between the amplitudes U_p and U_c and their sum. Their ratio determines the phase shift. This process is sometimes referred to as comparison [13].

There are two main methods for comparing the amplitudes of variable signals: simultaneous and multi-temporal [14]. Simultaneously provides high accuracy, but – lower performance. In addition, it has two options: aperiodic and periodic.

The scheme of simultaneous comparison is presented in Fig. 5. Here, the difference and total variable signals are simultaneously converted by two channels. The channels are composed according to the amplifiers (*A1*) and (*A2*), which receive input signals, rectifiers (*R1* and *R2*), which rectify the amplified signals. Further, low-pass filters (*LPF1* and *LPF2*) separate their constant components. The difference scheme DS calculates the difference of these constant components, which is proportional to the difference in the amplitudes of the input signals.

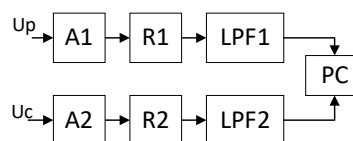

Fig. 5. Amplitude comparison circuit with simultaneous signal conversion

Here, the non-identity of the channel transfer coefficients causes a significant systematic error. Therefore, the accuracy of such a scheme is low.

In the scheme with multi-temporal aperiodic comparison (Fig. 6), there is one channel in which the difference and sum signals are converted in turn and stored. And then the difference calculator (*DC*) determines the difference.

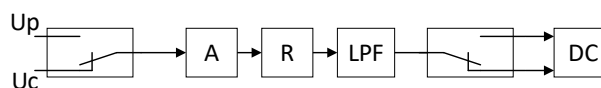

Fig. 6. Scheme for comparing amplitudes with multi-temporal aperiodic signal conversion

The scheme with periodic comparison is shown in Fig. 7.

The circuit consists of an amplifier (*A*), a rectifier (*R*), a low-pass filter (*LPF*), a control voltage generator (*CVG*), a bypass amplifier (*BA*) and a synchronous detector (*SD*), meters for the sum of the amplitudes $D(U_c + U_p)$ and the

difference amplitudes $D(U_c - U_p)$. The input switch (S), operating at a frequency Ω less than the frequency of the compared signals ω , converts the input signals into an amplitude-phase modulated signal, described by the following formula:

$$U_k = \frac{U_c - U_p}{2} \left[1 + \frac{U_c - U_p}{U_c + U_p} \text{sign} \sin(\Omega t + \varphi) \right] \times \sin \left(\omega t + \frac{\varphi_1 + \varphi_2}{2} \left[1 + \frac{\varphi_1 - \varphi_2}{\varphi_1 + \varphi_2} \text{sign} \sin(\omega t + \varphi) \right] \right), \quad (4)$$

where φ_1 , φ_2 and φ are the initial phases of the signals U_c , U_p and U_k .

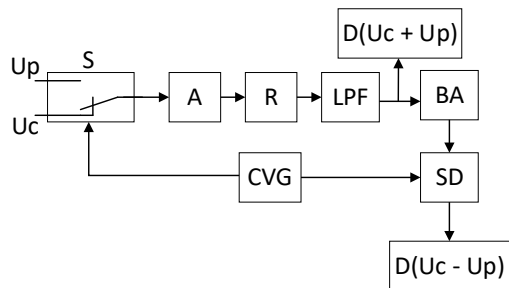

Fig. 7. Amplitude comparison circuit with periodic signal conversion

As can be seen from expression (4), the measurement information is included in the amplitude modulation depth factor. And phase modulation is a factor that, at low ratios of the frequencies of the measured signals and switching, makes it difficult to extract the depth of amplitude modulation through the combinational components that arise due to phase modulation and are superimposed on the spectrum of bypass amplitude modulation.

By measuring the depth of amplitude modulation, let's find the phase shift. If the frequency ratio of the measured signals and switching is greater than 100, then a channel with periodic comparison can provide a combined sensitivity threshold of about 0.0001 rad, sometimes even less [11]. In this case, the spectrum of bypass amplitude modulation and combination frequencies is spaced apart on the frequency axis.

The block diagram of phase shift measurement using periodic comparison is shown in Fig. 8. The circuit consists of the considered sum-difference circuit (SDS) and the amplitude comparison circuit (ACC) with periodic signal conversion (PSC), that is, ACC with PSC .

The phase shift is calculated by formula (3). The ratio of the frequencies of signals (ω) and switching (Ω), that is, ω/Ω must satisfy the condition $\omega \gg \Omega$. The absolute value of the frequency of the switched signal Ω cannot be less than 10 Hz, since at lower values of the switching frequency, the measurement result begins to be affected by flicker noise [14].

In order to achieve a low ratio of signal and switching frequencies, measures are taken to reduce the influence of combination frequencies due to phase modulation. One of these measures is the choice of the frequency ratio ω/Ω so that it is equal to [11]:

$$\frac{\omega}{\Omega} = n + \frac{1}{2}, \quad (5)$$

where n – an integer from 4 or more.

Then the upper and lower combination frequencies closest to the switching frequency move further away from the switching frequency at which the measured signal is obtained. This makes it possible to isolate the switching signal with a selective filter against the background of combination frequencies.

The second option is to choose the ratio so that it equals an integer, i. e.:

$$\frac{\omega}{\Omega} = n. \quad (6)$$

But in this case, the combination component falls exactly on the switching frequency. Now, in order to highlight the measured signal, it is necessary to reduce the level of combination frequencies. This is achieved using two-phase detection, which is difficult to implement. In addition, the initial phase of the switching signal is chosen so that the combinational component falling on the switching frequency is quadrature to it. Then the combination component can be further suppressed by the synchronous detector contained in the structure of the periodic comparison circuit.

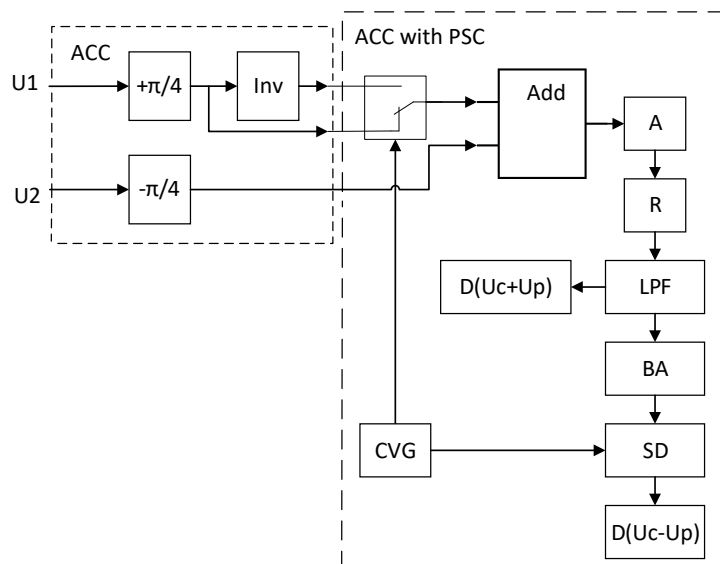

Fig. 8. Structural diagram of phase shift measurement

Both of these options: the first is the choice of frequency ratio $\omega/\Omega = n + 1/2$ and the second is the choice of frequency ratio $\omega/\Omega = n$ with a combination of two-phase detection and the choice of the corresponding initial phase of the switching signal, allowing to obtain a sensitivity threshold $(1 \cdot 10^{-4} \div 3 \cdot 10^{-5})$ rad [15]. The choice of one or the other method depends on the specific implementation. Some considerations in this regard are given in Table 1.

Table 1

The choice of one or the other method depending on the specific implementation

Scope of application	+	-
Units Hz	-	Large effect of flicker noise
More than 10 Hz	Sensitivity threshold $(1 \cdot 10^{-4} \div 3 \cdot 10^{-5})$ rad	-

In applications requiring measurements at frequencies in the unit Hz, the methods and tools considered here cannot be used due to the fact that the effect of flicker noise does not allow one to isolate the measured signal. In these cases, methods and means capable of reducing the effect of flicker noise should be used. These methods will be discussed further.

4. Conclusions

The considered methods and tools are used to build CPS components for measuring small phase shifts between low-frequency harmonic signals with a frequency above 10 Hz. Such systems are effectively used for electromagnetic sensing of inhomogeneous media such as land and water. In applications requiring measurements at frequencies in the unit Hz, the methods and tools considered here cannot be used due to the fact that the influence of flicker noise does not allow one to isolate the measured signal, as can be seen from Table 1. In these cases, it is possible to use methods and tools that can reduce the effect of flicker noise. These methods will be discussed further.

References

- Håkansson, A., Saad, A., Anand, A., Gjørsum, V., Robinson, H., Seel, K. (2021). Robust Reasoning for Autonomous Cyber-Physical Systems in Dynamic Environments. *Procedia Computer Science*, 192, 3966–3978. doi: <http://doi.org/10.1016/j.procs.2021.09.171>

- Lu, B.-N., Lähde, T. A., Lee, D., Meißner, U.-G. (2016). Precise determination of lattice phase shifts and mixing angles. *Physics Letters B*, 760, 309–313. doi: <http://doi.org/10.1016/j.physletb.2016.06.081>
- Lei, H., Huang, Y., Jiang, L., Gao, G., Zhang, J., Wu, P. (2022). Research on Fourier and Prony analysis algorithm of inter-harmonic in power system. *Energy Reports*, 8, 728–737. doi: <http://doi.org/10.1016/j.egy.2022.02.204>
- Gula, I. V. (2011). Rozrobka metodu vimiriuvannia fazovikh zsuviv signaliv. *Visnik Khmelnitckogo natsionalnogo universitetu. Tekhnichni nauki*, 5, 159–161.
- Wu, Z., Guo, W., Zhang, Q. (2022). Two-frequency phase-shifting method vs. Gray-coded-based method in dynamic fringe projection profilometry: A comparative review. *Optics and Lasers in Engineering*, 153, 106995. doi: <http://doi.org/10.1016/j.optlaseng.2022.106995>
- Pozar, D. M. (2012). *Microwave Engineering*. Wiley, 752.
- Behnam, H., Ohtsuki, S., Tanaka, M. (1998). Phase correction on ultrasound speed measurement. *Journal of the Acoustical Society of Japan (E)*, 19 (2), 141–150. doi: <http://doi.org/10.1250/ast.19.141>
- Lameko, A. L. (2019). Variational method of measuring angular phase difference. *Tekhnichna Elektrodynamika*, 2, 88–92. doi: <http://doi.org/10.15407/teched.2019.02.088>
- Kondratov, V. T. (1984). *Algoritmicheskie metody izmereniia mgnovennykh znachenii fazovogo dvoiga infranizkочastotnykh signalov*. Kyiv, 40.
- Buchma, I. M., Vzhushchak, M. (2003). Vplyv fliker-shumu v trakti nesuchoi chastoty nizkочastotnoho kanalu tovshchynomira stalevykh lystovykh konstruksii. *Metody i prylady kontroliu yakosti*, 10, 24–27.
- Miziuk, L. Ia., Podzharii, V. M., Protch, R. V. (1971). *Izmerenie invariantov magnitnogo polia pri eletrorazvedke*. Kyiv: Naukova dumka, 231.
- Buchma, I. (2017). Measurement of Phase Shift between the harmonic signals using binary sampling. *Computer Printing Technologies*, 1 (37), 78–91.
- Skripnik, Iu. A. (1971). *Metody vydeleniia izmeritelnoi informatsii iz garmonicheskikh signalov*. Kyiv: Naukova dumka, 276.
- Skripnik, Iu. A., Nizhenskii, A. D. (1964). O vybere chastoty pitaniia avtomaticheskogo kvaziuravnovesnennogo mosta s differentsialnym indikatorom. *Izvestiia vuzov. Priborostroenie*, 5, 14–22.
- Buchma, I. M. (2008). *Zasoby vymiriuvannia induktyvnoi elektrorozvidky ta vykhrostrumovoi diahnostyky*. Lviv: Lvivska politekhnika, 294.

Ihor Buchma, Doctor of Technical Sciences, Professor, Department of Computerized Automatic Systems, Lviv Polytechnic National University, Lviv, Ukraine, ORCID: <https://orcid.org/0000-0002-3477-2805>

✉ **Mykhailo Voichenko**, Postgraduate Student, Department of Computerized Automatic Systems, Lviv Polytechnic National University, Lviv, Ukraine, e-mail: voychenko.333@gmail.com, ORCID: <https://orcid.org/0000-0003-1765-8194>

✉ Corresponding author