



Farah M. Falahat,  
Mohamed R. Gomaa

# A REVIEW STUDY ON SOLAR TOWER USING DIFFERENT HEAT TRANSFER FLUID

The object of research is distinguishing the different heat transfer fluids (HTF) in concentrating solar power (CSP). CSP technologies are gaining more attention these years due to the fact that the world is facing significant problems, especially concerning environmental issues and the increasing electricity demand. The world countries are currently committed to mitigating climate change and limiting greenhouse gas emissions to keep the global temperature rising below 2 °C. As a result, renewable energy sources are required for power generation. One of the most widely used technologies is the solar tower, where mirrors reflect solar radiation into a central receiver on top of a tower that contains a working fluid known as heat transfer fluid. The HTF is one of the most important components in solar power tower plants used to transfer and store thermal energy to generate electricity. This study focuses on the HTF used in solar power towers and how it can affect the efficiency of the plant. The HTF discussed in this study are air, water/steam, molten salts, liquid sodium, and supercritical CO<sub>2</sub>. Among the review of HTFs in the solar tower system, the result of the research shows that the Air can reach the highest temperature while liquid sodium achieves the highest overall plant efficiency.

**Keywords:** solar energy, concentrated solar plants, solar power tower, heat transfer fluid.

Received date: 04.11.2022

Accepted date: 19.11.2022

Published date: 21.11.2022

© The Author(s) 2022

This is an open access article under the Creative Commons CC BY license

## How to cite

Falahat, F. M., Gomaa, M. R. (2022). A review study on solar tower using different heat transfer fluid. *Technology Audit and Production Reserves*, 5 (1 (67)), 38–43. doi: <https://doi.org/10.15587/2706-5448.2022.267560>

## 1. Introduction

One of the key concerns nowadays is reducing the environmental effects of the power production industry using traditional energy supplies. Furthermore, fossil fuel sources are depleting as the world's economy and population continue to rise. As a result, it is critical to make use of renewable energy sources, particularly solar energy [1–3]. In 2014, according to the international energy agency (IEA), solar thermal plants

will provide about 11 % of the world's electricity demand in 2050 [4] as cited in [5–8]. As shown in Fig. 1, different location of direct solar irradiation which are useable for the concentrated solar power and had a global total installed capacity of 6,451 MW in 2019 [9].

Thus, the object of study is distinguishing the different heat transfer fluids (HTF) in concentrating solar power (CSP).

This article aims to review a study on solar towers in different locations using different heat transfer fluids.

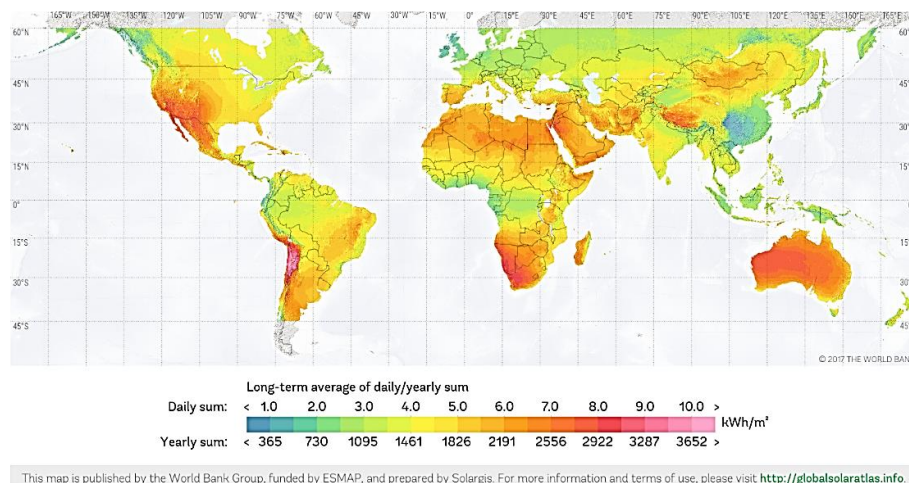

Fig. 1. Solar energy capacity worldwide [9]

## 2. Research methodology

**2.1. Concept of Solar Tower.** A solar power tower plant uses hundreds to thousands of sun-tracing mirrors (Fig. 2) to reflect the solar radiation to the receiver on top of a tower. The height of the tower depends on the plant energy output [10]. The incident energy is then transferred to a heat transfer fluid (HTF) from the receiver tube walls. The steam generating subsystem, which consists of heat exchangers, transmits the thermal energy from the heated HTF to the water. Water is heated from a subcooled liquid to superheated steam, then fed into a steam turbine to generate power [11].



**Fig. 2.** Field of mirrors focusing solar radiation on the central receiver atop the tower of a solar tower power plant [12]

The solar receiver on top of the tower act as a solar radiation absorber [13]. Authors of [11] stated that there are two types of receivers existing in solar tower plants, External and cavity receivers, Tubular receivers (usually formed by vertical pipes meeting the concentrated solar flux from the heliostats) working both with gas or liquid are the most common type of CSP receiver due to their simple fabrication, where incident energy is received and transferred through tubes to HTF [11, 13].

According to authors of [14], the cavity receiver is used in early commercial Solar Tower Power (STP) plants, and such receivers generally lead to lower radiation and convection thermal loss. The kind of receiver depends on the kind of heat transfer fluid and the power cycle (Rankine or Brayton) employed in the system [15], in addition to that authors of [13] stated that the heliostat field depends on the receiver type or vice-versa. In addition, the receiver efficiency increases with the heliostat efficiency (Fig. 3) [4, 16].

The receiver efficiency  $\eta_{th}$  is defined as the ratio of the average power absorbed by the working fluid  $Q_{abs}$  to the average power incident on the receiver  $Q_{inc}$  [10].

$$\eta_{th} = \frac{Q_{abs}}{Q_{inc}}. \quad (1)$$

The absorbed power (shown in Fig. 4) can be calculated from equation:

$$Q_{abc} = \dot{m} c_p (T_{out,htf} - T_{in,htf}), \quad (2)$$

where  $\dot{m}$  is the mass flow of HTF in kg/s;  $c_p$  is the average specific heat between HTF inlet and outlet temperature in J/kg·K [10].

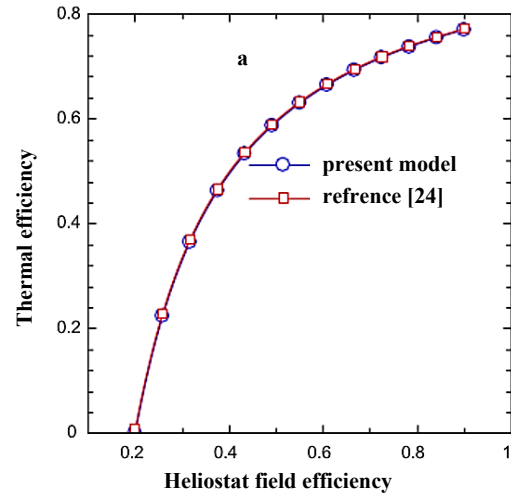

**Fig. 3.** Thermal efficiency of the receiver vs heliostat efficiency [4, 16]

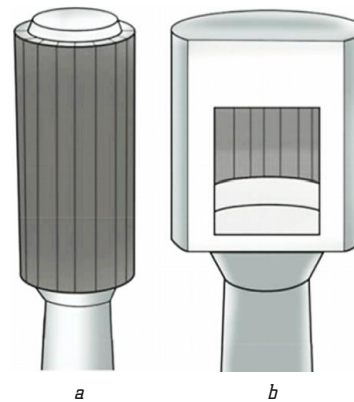

**Fig. 4.** Schematics of tubular receivers: a – external; b – cavity [11]

**2.2. Power Cycle Subsystem.** According to authors of [13] the power cycles as shown in Fig. 5 will be able to operate at greater operating temperatures with the next generation of high-temperature receivers, resulting in higher-efficiency power blocks.

This is projected to result in increased overall plant efficiency and cost savings. Generally, the power cycle subsystem can be Rankin, Bryton, and combined Rankin-Bryton cycle. Authors of [14] studied a single reheat steam Rankine cycle with Molten Salt (MS) and water/steam as HTF. The power cycle efficiency was 39 % with a turbine inlet temperature of 540 °C. Authors of [11] stated that the sCO<sub>2</sub> Brayton cycle could be used at temperatures higher than those that a Rankine cycle can handle. In addition to that sCO<sub>2</sub> Brayton cycle uses smaller turbo machinery and may achieve high efficiency with straightforward cycle configurations due to the higher density of sCO<sub>2</sub>, and it could potentially achieve 50 % efficiency if the turbine inlet temperatures were to be raised to 700 °C. Authors of [17] studied a hybrid solar power tower system with a pressurized air receiver and various multi-stage recuperative Brayton cycles. The result showed an increase in thermal efficiency. Authors of [16] analyzed the first and second low efficiency of solar tower combined cycle using supercritical CO<sub>2</sub>. The result shows that the energy and exergy efficiency of the power cycle was 44.46 % and 56.72 %, respectively. Additionally, authors of [4, 17] examined solar tower-assisted combined power plants to produce power, but the latter included producing hydrogen via electrolysis with a power cycle exergy efficiency of 52.74 %.

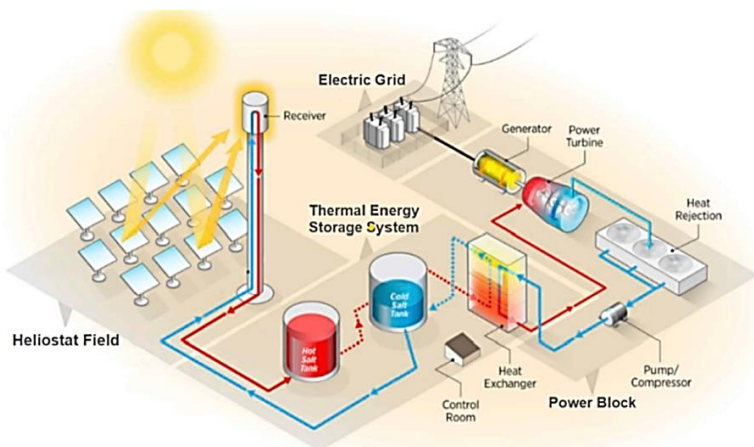

Fig. 5. Working model of Solar Tower (ST) power plant [11, 12]

**2.3. Heat Transfer Fluid.** Heat transfer fluids (HTF) play a critical role in collecting energy from the solar field and transporting it to the power plant [18]. According to authors of [10], the efficiency of solar tower systems is directly affected by the heat transfer fluids employed in solar receivers. Because the CSP uses a lot of HTF to run, it's critical to keep the HTF cost as low as possible while still maximizing performance. Apart from employing HTF as a heat transfer medium from the receiver to the steam generator, hot HTF can also be stored in insulated tanks for power generation during periods when there is no sunlight [18] (as shown in Fig. 6).

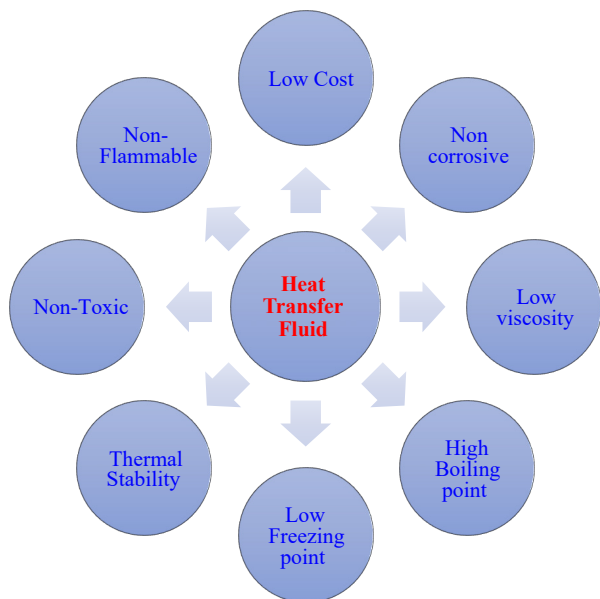

Fig. 6. Characteristics of the ideal HTFs [19]

New HTFs are being tested to use in solar towers besides conventional ones. Water is one of the fluids used as HTF due to its excellent thermophysical properties, availability, and environmental safety. However, when a high operating temperature is needed, it is preferred to use other HTFs that have a higher working temperature.

### 3. Research results and discussion

An increasing effort is being made to develop new types of HTFs in solar power tower plants to achieve

the maximum possible efficiency. This section discusses the HTF used in a solar tower, from conventional fluids to more innovative types.

**3.1. Water/Steam.** Water has good physical properties to be used as a heat transfer medium due to its high specific heat (4185 J/kg·K), availability, low viscosity, non-toxicity, and low cost [19]. If the receiver fluid is water/steam, the steam can be supplied straight to the steam turbine (direct steam production/generation) [20]. Let's suppose one of the other receiver fluids is used. In that case, the fluid's thermal energy must first be converted to water/steam via heat exchangers before being used to generate electricity in the turbine generator [5].

However, there is some issue related to using water as HTF as its corrosive nature and working temperature limits. Besides that, it can't be used when the sun goes down and on cloudy days, all of that results in less usage of water through the solar tower.

**3.2. Air.** Another HTF that can be used in solar power towers is air, air can be heated to a temperature as high as 1000 °C, and the hot air is used to generate steam that drives a turbine-generator to produce power. Air has a number of advantages, including the fact that it is non-corrosive and resistant to freezing and boiling. Furthermore, air is basically free, costless, non-polluting, and has no higher operational temperature limit [19]. In addition to that air doesn't need previous preheating, and the thermodynamic cycle is more efficient [20]. However, the air has low heat capacity and low thermal conductivity, which can be a disadvantage for using it. Equations of air thermophysical properties are found in equations (3) to (6), where  $T_s$  is the air static temperature in Kelvin, density ( $\rho$ ) in Kg/m<sup>3</sup>, specific heat ( $C_p$ ) in J/Kg·K dynamic viscosity ( $\mu$ ) in Kg/m·s, thermal conductivity ( $K$ ) in W/m·K [21].

$$K = -7.488 \cdot 10^{-3} + 1.708186 \cdot 10^{-4} \cdot T_s - 23.757762 \cdot 10^{-6} \cdot T_s^2 + 220.11791 \cdot 10^{-12} \cdot T_s^3; \quad (3)$$

$$C_p = 1061.332 - 0.432819 \cdot T_s + 1.02344 \cdot 10^{-3} T_s^2 - 6.47474 \cdot 10^{-7} \cdot T_s^3 + 1.3864 \cdot 10^{-10} \cdot T_s^4; \quad (4)$$

$$\mu = 4.112985 \cdot 10^{-6} + 5.052259 \cdot 10^{-8} \cdot T_s - 1.43462 \cdot 10^{-11} \cdot T_s^2 + 2.591403 \cdot 10^{-15} \cdot T_s^3; \quad (5)$$

$$\rho = \frac{P_s}{RT_s}. \quad (6)$$

Authors of [21] examined the thermal performance of solar towers that use air as an HTF in a volumetric air receiver in the MENA region; their results showed that at the receiver level, the HTF could reach 1080 °C which can ensure good performance of the power plant. Authors of [20] investigated the thermal energy storage (TES) system (honeycomb ceramic thermal energy storage) in a solar power plant that used air as HTF.

**3.3. Molten Salts.** Molten salts are one of the HTF used in solar power tower plants, not only to transfer the



thermal energy to the power cycle but also to store the energy and use it at night or on cloudy days to increase the efficiency of the plant. Sodium nitrate, potassium nitrate, calcium nitrate, and/or lithium nitrate are the most common components of molten salt [5]. A tubular receiver is the type of receiver used when molten salt is the HTF [22]. The molten is heated by reflected solar radiation from a heliostat field from 290 °C to 565 °C before entering the hot thermal storage tank. To generate steam, heated salts are fed from the storage system to the power cycle to generate electricity [22]. Equations (7) to (10) determine the thermophysical properties of molten salt (60 % NaNO<sub>3</sub>, 40 % KNO<sub>3</sub>) [23, 24].

$$K = 0.443 + 1.9 \cdot 10^{-4} \cdot T \text{ } ^\circ\text{C}; \quad (7)$$

$$\rho = 2090 - 0.636 \cdot T \text{ } ^\circ\text{C}; \quad (8)$$

$$C_p = 1443 + 0.172 \cdot T \text{ } ^\circ\text{C}; \quad (9)$$

$$\mu = 22.714 - 0.120 \cdot T \text{ } ^\circ\text{C} + 2.281 \cdot 10^{-4} \cdot T^2 \text{ } ^\circ\text{C} - 1.474 \cdot 10^{-7} \cdot T^3 \text{ } ^\circ\text{C}, \quad (10)$$

where  $T$  is the bulk temperature; density ( $\rho$ ) in Kg/m<sup>3</sup>; specific heat ( $C_p$ ) in J/Kg·°C; dynamic viscosity ( $\mu$ ) in Kg/m·s; thermal conductivity ( $K$ ) in W/m·°C.

Several researchers have studied the effect of using molten salts in solar power tower plants. For instance, authors of [25] examined the use of supercritical CO<sub>2</sub> Brayton cycle with solar salts (60:40 wt % sodium nitrate: potassium nitrate, single-component nitrate salts, and other salts) at 600–650 °C. Authors of [26] using the SAM software, examined the performance of three solar power tower plants in different locations in Algeria to find the most suitable location for the power plant working with molten salt (60 % NaNO<sub>3</sub>, 40 % KNO<sub>3</sub>) or what is known as solar salt in an external receiver. Authors of [27] studied the effect of different parameters including incident solar flux, inlet viscosity of molten salts, tube wall thickness, emissivity, and wind speed, and their influence on the system performance. Authors of [28] studied an integrated solar tower-based energy system with thermal energy storage to produce electricity and freshwater by desalination with a power output of 18.15 and 1.65 MW for residential demand and freshwater production, respectively.

**3.4. Liquid Sodium.** Liquid sodium has a higher operating temperature than molten salts hence, a more efficient power cycle. In addition, it has a high thermal conductivity, making sodium receivers best suited to high-temperature applications [11]. However, there is some issue related to using sodium as an HTF, including its reactivity with water and air [21, 29], and its cost, as it's considered relatively expensive, especially if it's used in the storage system [30]. Properties of liquid sodium are found from (11) to (14) equations [22].

$$K = 124.67 - 0.11381 \cdot T + 5.5226 \cdot 10^{-5} \cdot T^2 - 1.1842 \cdot 10^{-8} \cdot T^3; \quad (11)$$

$$\rho = 219 + 257.32(1 - T/2503.7) + 511.58(1 - T/2503.7)^{0.5}; \quad (12)$$

$$C_p = 1658.2 - 0.84790 \cdot T + 4.4541 \cdot 10^{-4} \cdot T^2 - 2.9926 \cdot 10^{-6} \cdot T^{-2}; \quad (13)$$

$$\mu = \ln(T) = -6.4406 - 0.395 \ln(T) + 556.835/T. \quad (14)$$

Authors of [23, 31] compared the performance of liquid sodium, molten salt, and Hitec (7 % NaNO<sub>3</sub>, 53 % KNO<sub>3</sub>, 40 % NaNO<sub>2</sub>). Their results showed that sodium offers higher overall efficiency due to its higher heat transfer coefficient and thermal conductivity (Fig. 7).

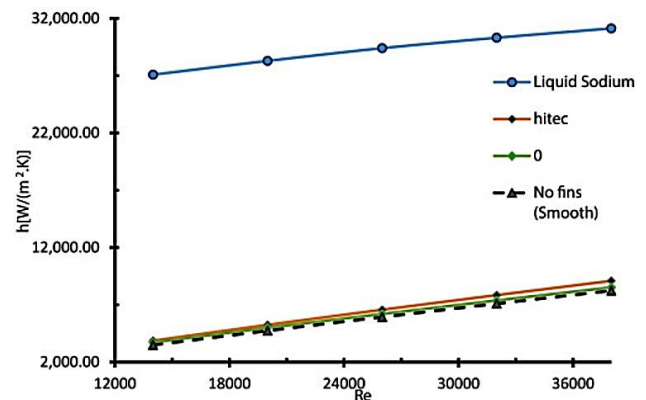

Fig. 7. Heat transfer coefficient with different heat transfer fluids [22]

Authors of [30] compared the efficiency of solar power towers using liquid sodium and KCl-MgCl<sub>2</sub> as HTF their results showed that using liquid sodium offers higher temperatures up to 750 °C and higher overall plant efficiency of up to 25 %.

**3.5. Supercritical CO<sub>2</sub>.** Supercritical CO<sub>2</sub> has proven to be an excellent HTF due to its non-corrosive nature, non-flammability, non-toxicity, and non-explosive nature. In addition to that, it is readily available, inexpensive, and stable at high temperatures [19]. Carbon dioxide acts as a supercritical fluid above its critical temperature 31.1 °C and critical pressure (7.38 MPa). It adopts intermediate properties between liquid and gas. Supercritical CO<sub>2</sub> can be utilized as the solar collector's HTF and the power cycle's operating fluid. As a result, no heat exchanger is required, resulting in more efficient and less complex power units, and because of its thermodynamic features, supercritical CO<sub>2</sub> in a Brayton cycle may operate at higher temperatures than steam and has the potential to be more efficient [32]. Authors of [4] studied the efficiency of a power tower plant using supercritical CO<sub>2</sub> as a heat transfer fluid in a cavity receiver with a receiver efficiency of 72.5 %. Author of [33] compared the supercritical steam cycle and supercritical CO<sub>2</sub> cycle in a solar power tower with a direct and indirect steam/supercritical CO<sub>2</sub> receiver. The result shows that using CO<sub>2</sub> will perform better at greater temperatures.

**3.6. Comparison between (HTFs).** Table 1 and Fig. 8 compare the reviewed HTFs based on recent research.

Choosing the best HTF is a key parameter to ensure the efficient performance of the solar tower. Among the reviewed HTF, water which is mostly used in earlier power plants, offers an excellent thermophysical property, however, there are some difficulties associated with it. Most importantly, it can't be used as a storage medium to ensure the plant's continued operation.

Comparison between the maximum temperature and efficiency for different HTF in the solar tower

**Table 1**

References	HTF	$T_{max}$ , °C	Receiver type	Receiver efficiency, %
[4]	Supercritical CO <sub>2</sub>	1000	Cavity receiver	72.5
[10]	Molten salt (60 % NaNO <sub>3</sub> , 40 % KNO <sub>3</sub> )	560	External tabular receiver	87.67
[10]	Liquid sodium	800	External receiver	87.78
[21]	Air	1090	Volumetric air receiver	88
[34]	Water/steam	530 super-heated steam	External receiver	89

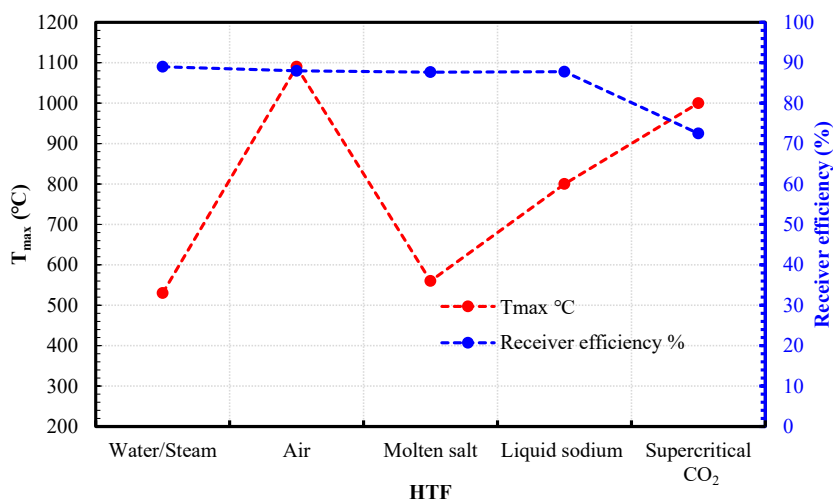

**Fig. 8.** Comparison between  $T_{max}$  and receiver efficiency for the reviewed HTFs

Molten salts are one of the most used HTF today due to their excellent properties in addition to using them as a storage medium; however, compared with liquid sodium based on the reviewed studies, the latter shows better results and higher temperature and efficiency. Using air have great potential as HTF for power tower and generating electricity. It also delivers high efficiency when compared to other fluids. Supercritical CO<sub>2</sub> has been well considered as HTF due to its low critical temperature and pressure and its safe operation compared with liquid sodium. With more development, new HTF are being tested for the solar power plant to maximize the thermal efficiency of the receiver and achieve higher overall plant efficiency.

In the future, the development of a mathematical model and optimization of the solar tower power plants with different HTF for different locations will be investigated. To explore the suitable HTF for the solar tower power plant for the limitation of weather conditions.

#### 4. Conclusions

In the course of the research, it is shown that choosing the best HTF is a key parameter to ensure the efficient performance of the solar tower plant. In order to choose the appropriate fluid for the solar power plant, several factors must be taken into account. These include the receiver type, storage system, and whether the fluid will be fed directly or indirectly to the power cycle.

In the course of the research, it is obtained that water, mostly used in earlier power plants, offers good thermophysical properties and high receiver efficiency of up to 89%; however, some difficulties are associated with it. Most importantly, it can't be used as a storage medium. Molten salts are one of the most used HTF today due to their excellent properties and the fact that it can be used as a storage medium that offers higher overall plant efficiency. Although molten salt

can reach high temperatures, it must be maintained above 290 °C. Otherwise, it starts to solidify. Therefore, it is necessary to avoid cold climate areas. On the other hand, liquid sodium with high thermal conductivity and heat transfer coefficient can offer higher receiver and plant efficiency; nevertheless, it should be well handled to ensure safe operation. Using air have great potential as HTF for power tower due to the elevated temperature. It can reach up to 1090 °C in areas with a high direct normal irradiance and long sunshine hours; however, its low thermal conductivity and heat capacity could be challenging. Supercritical CO<sub>2</sub> has been recently well considered as HTF and could potentially reach high temperatures up to 1000 °C.

Furthermore, it can serve as a working fluid circulating in the receiver and power cycle, thus reducing plant costs. With more development, new HTF are being tested for solar power plants to maximize the receiver's thermal efficiency and achieve higher overall plant efficiency.

#### Conflict of interest

The authors declare that they have no conflict of interest in relation to this research, whether financial, personal, authorship, or otherwise, that could affect the research and its results presented in this paper.

#### Financing

Presentation of research in the form of publication through financial support in the form of a grant from SUES (Support to Ukrainian Editorial Staff).

#### Data availability

The manuscript has no associated data.

#### References

- Gomaa, M. R., Matarneh, G. A., Shalby, M., AL-Rawashdeh, H. A. (2021). A State of the art Review on a Thermochemical Conversion of Carbonaceous Materials: Production of Synthesis Gas by Co-Gasification Process-Part I. *Current Alternative Energy*, 4 (1), 26–46. doi: <https://doi.org/10.2174/2405463104999200904115100>
- Gomaa, M. R., Al-Dmour, N., AL-Rawashdeh, H. A., Shalby, M. (2020). Theoretical model of a fluidized bed solar reactor design with the aid of MCRT method and synthesis gas production. *Renewable Energy*, 148, 91–102. doi: <https://doi.org/10.1016/j.renene.2019.12.010>
- Gomaa, M. R., Mustafa, R. J., Rezk, H. (2019). An experimental implementation and testing of a concentrated hybrid photo-voltaic/thermal system with monocrytalline solar cells using

- linear Fresnel reflected mirrors. *International Journal of Energy Research*, 43, 8660–8673. doi: <https://doi.org/10.1002/er.4862>
4. Mubeen, I., Khan, M. S., Abid, M., Ratlamwala, T. A. H., Yan, M. (2021). Performance assessment of a solar tower assisted combined cycle power plant using supercritical carbon dioxide as a heat transfer fluid. *International Journal of Exergy*, 36 (1), 30. doi: <https://doi.org/10.1504/ijex.2021.10040963>
  5. Samir Benammar. (2020). A Review Study on the Modeling and Simulation of Solar Tower Power Plants. *Journal of Solar Energy Research Updates*, 7, 100–121. doi: <https://doi.org/10.31875/2410-2199.2020.07.9>
  6. AlJuhani, M., Gomaa, M. R., Mandourah, T. S., Oreijah, M. M. A. (2021). The Environmental Effects on the Photovoltaic Panel Power: Jeddah Case Study. *Journal of Mechanical Engineering Research and Developments*, 44 (6), 251–262. Available at: <https://jmerd.net/06-2021-251-262/>
  7. Al-Rawashdeh, H. A., Al-Hwaiti, M., Yaseen, A., Behiri, M. R. G. (2021). Influence of Partial Replacement of Cement by Various Percentage of Scoria in Self-Compacting Concrete on Thermal Conductivity in the Jordan Building Construction for Energy Saving. *International Review of Mechanical Engineering (IREME)*, 15 (7), 385–393. doi: <https://doi.org/10.15866/ireme.v15i7.20929>
  8. Shalby, M., Elhanafi, A., Walker, P., Dorrell, D. G., Salah, A., Gomaa, M. R. (2021). Experimental Investigation of the Small-scale Fixed Multi-chamber OWC Device. *Chinese Journal of Mechanical Engineering*, 34 (1). doi: <https://doi.org/10.1186/s10033-021-00641-9>
  9. *Concentrated solar power had a global total installed capacity of 6,451 MW in 2019* (2019). Available at: <https://heliocsp.com/concentrated-solar-power-had-a-global-total-installed-capacity-of-6451-mw-in-2019/>
  10. Adiyaman, G., Çolak, L., Horuz, İ. (2019). The Impact of Heat Transfer Fluids on the Sustainable Solutions for Solar Power Tower. *4<sup>th</sup> International Sustainable Buildings Symposium*, 647–660. doi: <https://doi.org/10.5772/intechopen.87836>
  11. Zheng, M., Zapata, J., Asselineau, C.-A., Coventry, J., Pye, J. (2020). Analysis of tubular receivers for concentrating solar tower systems with a range of working fluids, in exergy-optimised flow-path configurations. *Solar Energy*, 211, 999–1016. doi: <https://doi.org/10.1016/j.solener.2020.09.037>
  12. Shagdar, E., Lougou, B. G., Shuai, Y., Anees, J., Damdinsuren, C., Tan, H. (2020). Performance analysis and techno-economic evaluation of 300 MW solar-assisted power generation system in the whole operation conditions. *Applied Energy*, 264, 114744. doi: <https://doi.org/10.1016/j.apenergy.2020.114744>
  13. Merchán, R. P., Santos, M. J., Medina, A., Calvo Hernández, A. (2022). High temperature central tower plants for concentrated solar power: 2021 overview. *Renewable and Sustainable Energy Reviews*, 155, 111828. doi: <https://doi.org/10.1016/j.rser.2021.111828>
  14. Yang, H., Li, J., Huang, Y., Kwan, T. H., Cao, J., Pei, G. (2020). Feasibility research on a hybrid solar tower system using steam and molten salt as heat transfer fluid. *Energy*, 205, 118094. doi: <https://doi.org/10.1016/j.energy.2020.118094>
  15. Adebayo, V. O., Olalekan, O. (2017). *Solar thermal with Solar Tower*. Available at: [https://www.researchgate.net/publication/319471818\\_Solar\\_thermal\\_with\\_Solar\\_Tower\\_Power\\_generation](https://www.researchgate.net/publication/319471818_Solar_thermal_with_Solar_Tower_Power_generation)
  16. Okonkwo, E. C., Okwose, C. F., Abid, M., Ratlamwala, T. A. H. (2018). Second-Law Analysis and Exergoeconomics Optimization of a Solar Tower–Driven Combined-Cycle Power Plant Using Supercritical CO<sub>2</sub>. *Journal of Energy Engineering*, 144 (3). doi: [https://doi.org/10.1061/\(asce\)ey.1943-7897.0000534](https://doi.org/10.1061/(asce)ey.1943-7897.0000534)
  17. Mohammadi, K., McGowan, J. G., Saghafifar, M. (2019). Thermoeconomic analysis of multi-stage recuperative Brayton power cycles: Part I-hybridization with a solar power tower system. *Energy Conversion and Management*, 185, 898–919. doi: <https://doi.org/10.1016/j.enconman.2019.02.012>
  18. Agyekum, E. B., Adebayo, T. S., Bekun, F. V., Kumar, N. M., Panjwani, M. K. (2021). Effect of Two Different Heat Transfer Fluids on the Performance of Solar Tower CSP by Comparing Recombination Supercritical CO<sub>2</sub> and Rankine Power Cycles, China. *Energies*, 14 (12), 3426. doi: <https://doi.org/10.3390/en14123426>
  19. Czaplicka, N., Grzegórska, A., Wajs, J., Sobczak, J., Rogala, A. (2021). Promising Nanoparticle-Based Heat Transfer Fluids – Environmental and Techno-Economic Analysis Compared to Conventional Fluids. *International Journal of Molecular Sciences*, 22 (17), 9201. doi: <https://doi.org/10.3390/ijms22179201>
  20. Li, Q., Bai, F., Yang, B., Wang, Y., Xu, L., Chang, Z. et al. (2018). Dynamic simulations of a honeycomb ceramic thermal energy storage in a solar thermal power plant using air as the heat transfer fluid. *Applied Thermal Engineering*, 129, 636–645. doi: <https://doi.org/10.1016/j.applthermaleng.2017.10.063>
  21. Hassani, S. E., Ouali, H. A. L., Raillani, B., Moussaoui, M. A., Mezrhah, A., Amraoui, S. (2020). Thermal Performance of Solar Tower Using Air as Heat Transfer Fluid under MENA Region Climate. *2020 5th International Conference on Renewable Energies for Developing Countries (REDEC)*. doi: <https://doi.org/10.1109/redec49234.2020.9163893>
  22. Gasa, G., Lopez-Roman, A., Prieto, C., Cabeza, L. F. (2021). Life Cycle Assessment (LCA) of a Concentrating Solar Power (CSP) Plant in Tower Configuration with and without Thermal Energy Storage (TES). *Sustainability*, 13 (7), 3672. doi: <https://doi.org/10.3390/su13073672>
  23. Shatnawi, H., Lim, C. W., Ismail, F. B., Aldossary, A. (2021). An optimisation study of a solar tower receiver: the influence of geometry and material, heat flux, and heat transfer fluid on thermal and mechanical performance. *Heliyon*, 7 (7), e07489. doi: <https://doi.org/10.1016/j.heliyon.2021.e07489>
  24. Dincer, I., Rosen, M. A., Khalid, F. (2018). 3.16 Thermal Energy Production. *Comprehensive Energy Systems*, 3, 673–706. doi: <https://doi.org/10.1016/b978-0-12-809597-3.00335-7>
  25. Turchi, C. S., Vidal, J., Bauer, M. (2018). Molten salt power towers operating at 600–650 °C: Salt selection and cost benefits. *Solar Energy*, 164, 38–46. doi: <https://doi.org/10.1016/j.solener.2018.01.063>
  26. Rouibah, A., Benazzouz, D., Kouider, R., Al-Kassir, A., García-Sanz-Calcedo, J., Maghzili, K. (2018). Solar Tower Power Plants of Molten Salt External Receivers in Algeria: Analysis of Direct Normal Irradiation on Performance. *Applied Sciences*, 8 (8), 1221. doi: <https://doi.org/10.3390/app8081221>
  27. Yu, Q., Fu, P., Yang, Y., Qiao, J., Wang, Z., Zhang, Q. (2020). Modeling and parametric study of molten salt receiver of concentrating solar power tower plant. *Energy*, 200, 117505. doi: <https://doi.org/10.1016/j.energy.2020.117505>
  28. Sorgulu, F., Dincer, I. (2018). Design and analysis of a solar tower power plant integrated with thermal energy storage system for cogeneration. *International Journal of Energy Research*, 43 (12), 6151–6160. doi: <https://doi.org/10.1002/er.4233>
  29. Manzolini, G., Lucca, G., Binotti, M., Lozza, G. (2021). A two-step procedure for the selection of innovative high temperature heat transfer fluids in solar tower power plants. *Renewable Energy*, 177, 807–822. doi: <https://doi.org/10.1016/j.renene.2021.05.153>
  30. Polimeni, S., Binotti, M., Moretto, L., Manzolini, G. (2018). Comparison of sodium and KCl-MgCl<sub>2</sub> as heat transfer fluids in CSP solar tower with sCO<sub>2</sub> power cycles. *Solar Energy*, 162, 510–524. doi: <https://doi.org/10.1016/j.solener.2018.01.046>
  31. Liu, J., He, Y., Lei, X. (2019). Heat-Transfer Characteristics of Liquid Sodium in a Solar Receiver Tube with a Nonuniform Heat Flux. *Energies*, 12 (8), 1432. <https://doi.org/10.3390/en12081432>
  32. Aguilar, R., Valenzuela, L., Avila-Marin, A. L., Garcia-Ybarra, P. L. (2019). Simplified heat transfer model for parabolic trough solar collectors using supercritical CO<sub>2</sub>. *Energy Conversion and Management*, 196, 807–820. doi: <https://doi.org/10.1016/j.enconman.2019.06.029>
  33. Silva-Pérez, M. A. (2017). Solar power towers using supercritical CO<sub>2</sub> and supercritical steam cycles, and decoupled combined cycles. *Advances in Concentrating Solar Thermal Research and Technology*, 383–402. doi: <https://doi.org/10.1016/b978-0-08-100516-3.00017-4>
  34. Saghafifar, M., Mohammadi, K., Powell, K. (2020). Design and analysis of a dual-receiver direct steam generator solar power tower plant with a flexible heliostat field. *Sustainable Energy Technologies and Assessments*, 39, 100698. doi: <https://doi.org/10.1016/j.seta.2020.100698>

**Farah M. Falahat**, Postgraduate Student, Department of Mechanical Engineering, Al-Hussein Bin Talal University, Ma'an, Jordan, ORCID: <https://orcid.org/0000-0001-7067-0104>

✉ **Mohamed R. Gomaa**, Assistant Professor, Department of Mechanical Engineering, Al-Hussein Bin Talal University, Ma'an, Jordan, e-mail: [Behiri@bhit.bu.edu.jo](mailto:Behiri@bhit.bu.edu.jo), ORCID: <https://orcid.org/0000-0003-4799-6119>

✉ Corresponding author