



Farid Agayev,
Javid Karimov,
Almaz Mehdiyeva,
Sevinj Guliyeva

DESIGN PRINCIPLES OF DIGITAL-TO-ANALOG CONVERSION IN INFORMATION TRANSFORMATION

The object of study is digital-to-analog converter (DAC). The meaning of DAC, their design and control of various types of switches, as well as some logic elements that can act as a switch, as well as the principles of DAC operation based on various series, microcircuits were considered. The resistance of a 4-bit DAC circuit was calculated and, accordingly, the change in the output voltage when applying the corresponding combined input voltage was studied, and a timing diagram was accordingly developed. Using 1-state and toggle physical switches, schematics are established and side effects are learned. Ladder circuit established using $R-2R$ type dividers as voltage dividers. The object of the research is to find and learn the most technologically advantageous concept in order to provide good communication between all equipments by transferring information from digital to analog in the industrial field as well as in other areas where automation is used. One of the biggest challenges in this research is to determine the smallest binary values. Before the use of electronic logic elements such as counters, bistable physical switches were used to create a break or connect state in the circuit, which caused additional energy and time loss or abrasion because of large voltages occur across the switches. The biggest issue was that when manufacturing integrated digital-to-analog converters, producing the right resistors with very different values is really difficult. As a result of this research, it is seen that the use of physical switches is unnecessary as a demand of today's modern technology, and integrated microcircuits are good to replace them. The programming of digital-to-analog converters on programmable hardware devices such as Arduino and Raspberry Pi were mentioned. If to predict the near future, digital-to-analog transmission will be realized only by only using logic elements, and this will change both their energy efficiency and size for the better.

Keywords: digital-to-analog converter, analog transmission, digital transmission, measurement result, microcircuit.

Received date: 09.11.2022

Accepted date: 24.11.2022

Published date: 25.11.2022

© The Author(s) 2022

This is an open access article
under the Creative Commons CC BY license

How to cite

Agayev, F., Karimov, J., Mehdiyeva, A., Guliyeva, S. (2022). Design principles of digital-to-analog conversion in information transformation. *Technology Audit and Production Reserves*, 5 (1 (67)), 18–21. doi: <https://doi.org/10.15587/2706-5448.2022.267770>

1. Introduction

Simultaneous processing of information in analog and digital form is widely used in electronic systems. This is explained by the fact that initial information with different physical quantities and processes is analog in nature. It is easy to convert such information into digital form. After that, it is also required to describe the result of digital processing in an analog form. Therefore, the use of digital processing of information requires the presence of a device that converts analog and digital signals into one another [1–3]. Analog-to-digital and digital-to-analog converters play the role of such a device [4].

Analog-to-digital converter (ADC) is a device that converts input analog signals into corresponding digital signals. Suitable for work with computers and other digital devices [5, 6]. Digital-to-analog converter (DAC) – converts digital signals to analog signals and serves to connect the forming digital devices to signal processing devices with analog information. They are widely used in controlling analog devices with the help of a com-

puter [7]. Nowadays, microelectronic DACs are the most widely used. They are generally divided into linear and intermediate converters. A simple DAC scheme includes: reference voltage sources, resistive or active dividers, analog switches. An $R-2R$ matrix is used as a divider. Operational amplifiers collect the currents generated by connecting the appropriate sources.

The wide application of digital computing devices and first of all microprocessors and microcomputers to various fields of science and technology has revealed the issue of connecting computers to various technical devices. As a rule, in technical systems, the information that characterizes any measured parameter that comes from primary transmitters is in analog form as a voltage level.

Thus, *the object of study* is digital-to-analog converter (DAC). *The aim of this article* is to analyze of the meaning of digital-to-analog converters, their design and control of various types of switches, as well as some logic elements that can act as a switch, as well as the principles of DAC operation based on various series.

2. Materials and Methods

2.1. Design principles of digital-to-analog converters.

A simple scheme for converting a given number into a proportional voltage using a binary code is shown in Fig. 1.

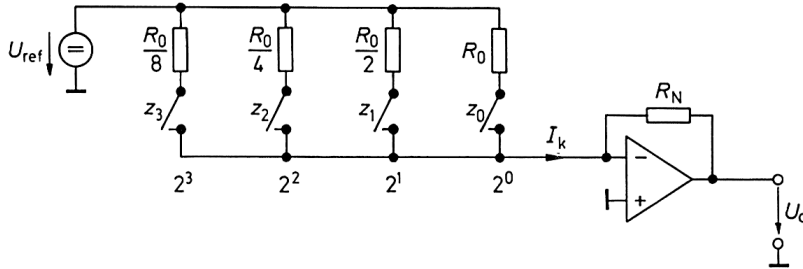

Fig. 1. A simple scheme for converting a given number into a proportional voltage using a binary code

The resistors are designed so that when the switches are closed, currents corresponding to their respective bit weights will flow through them. The switches must be closed when the corresponding bit corresponds to a logic signal of «1». Since the operational amplifier has a feedback loop through the R_N resistor, the summation point remains at zero potential [8, 9].

Thus, the current components are added without affecting each other and the result is obtained:

$$U_0 = -U_{ref} \frac{R_N}{R_0} (8z_3 + 4z_2 + 2z_1 + z_0), \tag{1}$$

$$U_0 = -U_{ref} \frac{R_N}{R_0} Z \text{ at } 0 \leq Z \leq 15, \tag{2}$$

where U_{ref} is the voltage applied to the circuit; U_0 is the output voltage.

Additional parallel resistors ($1/16 R_0, 1/32 R_0$ etc.) can be added to the circuit according to the number of bits required to be converted as input voltage. The highest precision is required for the resistor of the most significant bit. If the least significant bit is not to be lost by errors in the more significant bits, the value of the resistor for 2^n -bit (Z_n) must be low:

$$\frac{\Delta R}{R} = \frac{1}{2^{n+1}}. \tag{3}$$

So a resistor value of 3 % for 24-bit should be better than 0.05 % for 2^{10} bits. To get straight binary codes, it is necessary to expand the circuit with 4 resistors corresponding to each decade. The values of the resistors are 10 times smaller than their previous four.

2.2. Digital-to-analog converters based on two-position switches. The disadvantage of the above R/A converter is the formation of large voltages on the switches. Therefore, the application of electronic switches is more preferred. In addition, the achievable switching frequency is low because proper charging and reverse charging of empty capacitances are required. These problems can be avoided

if two-position switches are used to connect the resistors to the sump or ground circuit, as shown in Fig. 2.

Therefore, the current through each resistor remains constant. It has another advantage that, unlike the previous circuit, the load of the supply voltage source is constant and its internal resistance does not have to be zero.

The input resistance of the network and thus the load resistance of the reference voltage source are determined as follows:

$$R_i = R_0 \frac{R_0}{2} \frac{R_0}{4} \frac{R_0}{8} = \frac{1}{15} R_0, \tag{4}$$

$$U_0 = -U_{ref} \frac{R_N}{R_0} z. \tag{5}$$

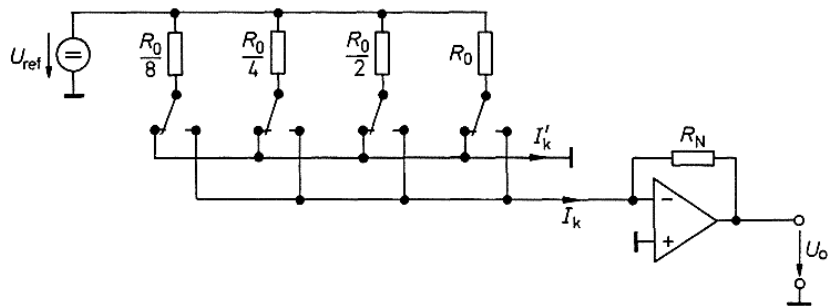

Fig. 2. Two-position switches are used to connect the resistors to the sump or ground circuit

2.3. Ladder/Matrix circuit. When manufacturing integrated D/A converters, manufacturing accurate resistances of widely varying values is both extremely difficult and makes its design expensive and impractical for lower-end DACs. Obviously, the binary-weighted DAC is designed based on a closed-loop operational amplifier that uses a summing amplifier topology [10]. Although this type of data converter configuration works well for a D/A converter with multiple bit resolutions, a simpler approach is to use an $R-2R$ resistive ladder network that requires only two precision resistors [11]. An $R-2R$ resistive ladder network uses only two resistor values, one is the base value of the first resistor «R» regardless of how many bits are used to make up the matrix, and the other is a value of «2R» that is twice the original value [6, 12, 13]. So, for example, if just use a 1 kΩ resistor for the base resistor «R», it is necessary to equivalently use a 2 kΩ resistor for «2R» (or multiples of them since the base value of R is not too critical). This means that with this type of DAC it is easier to maintain the required accuracy of the resistors across the ladder network.

2.4. R-2R Resistive Ladder Network. As the name suggests, the «ladder» description comes from the ladder-like configuration of resistors used within the network. The $R-2R$ resistive ladder network provides a simple means of converting digital voltage signals to an equivalent analog output. Input voltages are applied to the ladder network at various points along its length, and more input points lead to better results. The output signal resulting from all these input a voltage point is taken from the end of the ladder which is used to drive the inverting input of the operational amplifier.

The $R-2R$ resistive ladder network is nothing more than long strings of resistors connected in parallel and in series, which act as voltage dividers connected along their length, and whose output voltage depends only on the interaction of the input voltages. Fig. 3 illustrates an example of a simple $R-2R$ voltage divider circuit.

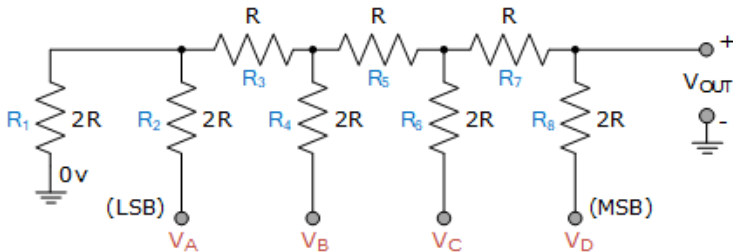

Fig. 3. Voltage dividers

2.5. Creation of $R-2R$ type Digital-to-analog converter. When a digital-to-analog converter is made, combinational or step-by-step logic circuits, registers, and counters are used to control it. When designing the structure, the number of n -bits is changed depending on the area where the circuit will be used. It is very easy to design and control and program DAC circuits on products like Arduino and Raspberry Pi. As an example of DAC microcircuits, it is known the products such as 8-bit DAC0808.

3. Results and Discussion

It is already known that in $R-2R$ DAC circuits, let's use a resistor at the base two values, and when apply a signal corresponding to a logic level at the inputs A, B, C, and D, it is possible to obtain the necessary voltage at the output. And accordingly let's also built the combination table for 4-bit DAC. And it is also known that these circuits use either physically controlled switches or various electronic elements that can handle the duty of the switch. However, with the support of modern technology, all these elements can be combined in a single microcircuit. One of them is a 74LS93 series 4-bit and binary counting microcircuit. This counter has two stable states, J and K, which are also asynchronous and hence called ripple. Since 4 J-K FFs are used in this counter, its output frequency is characterized by coefficients of 2, 4, 8 and 16. A clear description of the scheme is given in Fig. 4. Let's note that for the counter to count from 0000 to 1111, the external CLKB input must be connected to the QA (pin-12) output and the input pulses must be applied to the CLKA (pin-14) input.

According to this simple scheme, with the application of a clock pulse, the outputs: QA, QB, QC and QD change one step. The input of the operational amplifier

detects this step change and provides an inverse voltage relative to the binary code at the inputs of the $R-2R$ circuit. The output voltage value for each step will be as given in Fig. 5. The timing diagram of the $R-2R$ type Digital-to-analog converter working with this method is depicted in Fig. 6.

It is clear that the output voltage of the operational amplifier varies from zero volts to a maximum negative voltage.

Simple circuits like this can be used to drive an operational amplifier connected to a lamp whose output needs to be dimmed, or to change the speed of a DC motor continuously from slow to fast and back to slow again at a rate determined by the clock cycle.

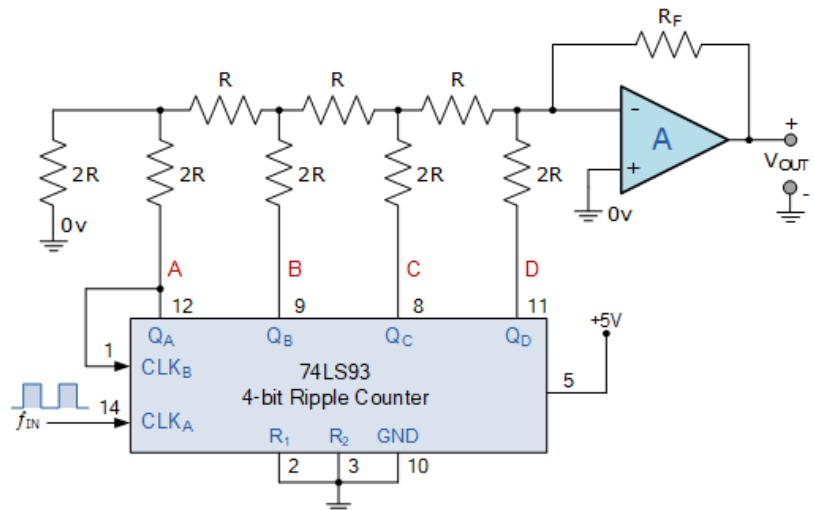

Fig. 4. The clear description of the scheme

Digital Inputs				Digital Inputs	V_{out}
D	C	B	A	$1*VD + 1/2*VC + 1/4*VB + 1/8*VA$	in Volts
0	0	0	0	$0*5 + 0*5 + 0*5 + 0*5$	0
0	0	0	1	$0*5 + 0*5 + 0*5 + 1/8*5$	-0.625
0	0	1	0	$0*5 + 0*5 + 1/4*5 + 0*5$	-1.25
0	0	1	1	$0*5 + 0*5 + 1/4*5 + 1/8*5$	-1.875
0	1	0	0	$0*5 + 1/2*5 + 0*5 + 0*5$	-2.50
0	1	0	1	$0*5 + 1/2*5 + 0*5 + 1/8*5$	-3.125
0	1	1	0	$0*5 + 1/2*5 + 1/4*5 + 0*5$	-3.75
0	1	1	1	$0*5 + 1/2*5 + 1/4*5 + 1/8*5$	-4.375
1	0	0	0	$1*5 + 0*5 + 0*5 + 0*5$	-5.00
1	0	0	1	$1*5 + 0*5 + 0*5 + 1/8*5$	-5.625
1	0	1	0	$1*5 + 0*5 + 1/4*5 + 0*5$	-6.25
1	0	1	1	$1*5 + 0*5 + 1/4*5 + 1/8*5$	-6.875
1	1	0	0	$1*5 + 1/2*5 + 0*5 + 0*5$	-7.50
1	1	0	1	$1*5 + 1/2*5 + 0*5 + 1/8*5$	-8.125
1	1	1	0	$1*5 + 1/2*5 + 1/4*5 + 0*5$	-8.75
1	1	1	1	$1*5 + 1/2*5 + 1/4*5 + 1/8*5$	-9.375

Fig. 5. Output voltage according to digital inputs

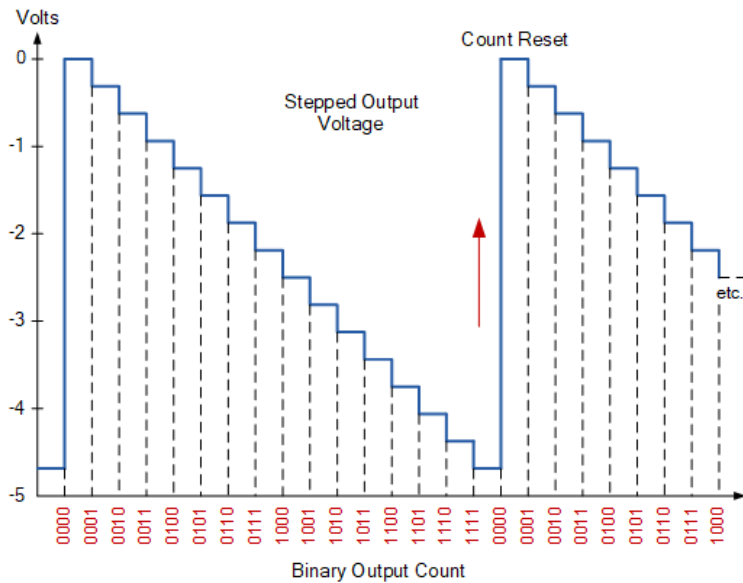

Fig. 6. Timing diagram of the $R-2R$ type Digital-to-analog converter

A limitation of this study is designing custom resistor elements that are equivalent to each bit value. In addition, there are issues like the spark and energy loss due to friction when using physical switches. We have experienced in this research that under most conditions meters can handle physical switches without any problems and with good efficiency. On the other hand, our recommendation to those who want to try these experiences is to use a counter with the appropriate number of bits, taking into account the scale of information they want to transfer. Looking at the future trends, it can be said that the manual electronic circuit elements are now out of date, and they will be completely replaced by the microelements, which can be integrated and programmable. By keeping up with this tendency, let's utilize from this kind of electronic equipment in our future works.

4. Conclusions

The meaning of digital-to-analog converters, their design and control of various types of switches, as well as some logic elements that can act as a switch, as well as the principles of DAC operation based on various series, were considered microcircuits. The resistance of a 4-bit DAC circuit was calculated and, accordingly, the change in the output voltage when applying the corresponding combined input. In this article, we met the principles of building of digital-to-analog converters and the equipment used in them are met. As can be seen, converters installed on the $R-2R$ network are the most convenient in terms of economy and construction and use. According to the table in Fig. 5, when all the outputs of the counter (A, B, C, D) are equal to the logical «0» value, the output voltage of the circuit will be 0. It has been experienced that the output voltage of the circuit is 9.375 V when all the outputs of the counter are equal to the logic «1» signal. In this study, 74LS93 counter instead of physical switch was used. Let's recommend using more advanced counters to transfer information on a larger scale.

Conflict of interest

The authors declare that they have no conflict of interest in relation to this research, whether financial, personal,

authorship or otherwise, that could affect the research and its results presented in this paper.

Financing

Presentation of research in the form of publication through financial support in the form of a grant from SUES (Support to Ukrainian Editorial Staff).

Data availability

The manuscript has no associated data.

References

1. Tietze, U., Schenk, C., Gamm, E. (2008). *Electronic Circuits*. doi: <https://doi.org/10.1007/978-3-540-78655-9>
2. Pashayev, A. M., Hasanov, A. R., Iskandarov, I. A., Abdurahimov, F. A. (2014). *Fundamentals of electronic devices 3 (Digital devices)*. Baku: Editorial office «Maarif», 328.
3. Rustamova, D. F., Mehdiyeva, A. M. (2021). Features of Digital Processing of Non-stationary Processes in Measurement and Control. *Lecture Notes in Networks and Systems*. Cham: Springer, 592–598. doi: https://doi.org/10.1007/978-3-030-77448-6_58
4. Wang, Guo, Zhou, Wu, Luan, Liu, Ding, Wu, Liu. (2019). A 3GS/s 12-bit Current-Steering Digital-to-Analog Converter (DAC) in 55 nm CMOS Technology. *Electronics*, 8 (4), 464. doi: <https://doi.org/10.3390/electronics8040464>
5. Majidov, S. (2012). *Electronics 2*. Baku: Editorial office «Elm», 198.
6. Agayev, F. H., Mehdiyeva, A. M. (2017). *Corrective filtering in electrical signal conversion and digital processing*. Baku: Azernashr, 168.
7. *Digital-to-Analog and Analog-to-Digital Converters*. Available at: https://www.ee.iitb.ac.in/~sequel/ee101/mc_dac_1.pdf
8. Humbatov, R. T. (2002). *Electronics II*. Baku: Editorial office «Maarif», 284.
9. Scherz, P., Monk, S. (2000). *Practical Electronics for Inventors*. MC Graw Hill, 1056. Available at: <http://instrumentacion.qi.fcen.uba.ar/libro/Scherz.pdf>
10. Horowitz, P., Hill, W. (2015). *The Art of Electronics*. New York: Cambridge University Press, 1224.
11. *R-2R DAC*. *Electronics-tutorials*. Available at: <https://www.electronics-tutorials.ws/combination/r-2r-dac.html>
12. Maini, A. K. (2007). *Digital Electronics Principles, Devices and Applications*. Wiley, 741. Available at: <https://www.shahucolegelatur.org.in/Department/Studyaterial/sci/it/BCA/FY/digielec.pdf>
13. Bryant, J., Kester, W. *Analog-Digital Conversion*. Fundamentals of sampled data systems, 120. Available at: <https://www.analog.com/media/en/training-seminars/design-handbooks/Data-Conversion-Handbook/Chapter2.pdf>

Ferid Agayev, PhD, Associate Professor, Head of the Faculty of Information Technology and Control, Azerbaijan State Oil and Industry University, Baku, Azerbaijan, ORCID: <https://orcid.org/0000-0001-5435-8719>

✉ **Javid Karimov**, Postgraduate Student, Azerbaijan State Oil and Industry University, Baku, Azerbaijan, e-mail: jafar_kerim@mail.ru, ORCID: <https://orcid.org/0000-0002-9399-3464>

Almaz Mehdiyeva, PhD, Associate Professor, Azerbaijan State Oil and Industry University, Baku, Azerbaijan, ORCID: <https://orcid.org/0000-0002-3962-3980>

Sevinj Guliyeva, Assistant Professor, Azerbaijan State Oil and Industry University, Baku, Azerbaijan, ORCID: <https://orcid.org/0000-0002-8128-1347>

✉ Corresponding author