

Viktor Svitlytskyi,  
Tetiana Sahala

## ADJUSTMENT OF THE AXIAL LOAD ON THE BIT WHEN HOLE DEEPENING BY USING THE SCREW MECHANISM

The object of the research is a screw mechanism for adjusting the axial load on the bit during a hole deepening. Mathematical modeling of dynamic processes that occur in the drill string during the hole deepening in deep wells is considered. It is shown that in the process of hole deepening, the longitudinal oscillations are proportional in their intensity to the torsional ones. Obtained boundary conditions for mathematical models of the column with the use of a shock absorber or a screw amplifier.

In the course of research, it was found that the screw working mechanism of the axial load creates a relationship between the axial load on the bit and the torque on the screw. This makes it possible to install safety devices that limit the torque of the drive shaft (reciprocating engine, rotor). It is shown that various types of energy supplied to the punch, which are transformed by the punching motor and amplified due to the axial (screw) amplifier installed above the bit, ensure the rotary-progressive movement of the ball bit and increase the drilling performance. It was determined that the obtained dependencies take into account the change in time of the axial load and torque depending on the parameters of the axial amplifier and the geological and technical conditions of drilling and the arrangement of the bottom of the drill string.

The research results will be useful to scientists and specialists of the oil and gas industry during the physical modeling of the processes of adjusting the axial load on the bit during a hole deepening by using a screw mechanism.

**Keywords:** screw mechanism, axial load, ball bit, adjustment, drill string, hole deepening.

Received date: 19.01.2023

Accepted date: 27.02.2023

Published date: 28.02.2023

© The Author(s) 2023

This is an open access article  
under the Creative Commons CC BY license

### How to cite

Svitlytskyi, V., Sahala, T. (2023). Adjustment of the axial load on the bit when hole deepening by using the screw mechanism. *Technology Audit and Production Reserves*, 1 (1 (69)), 40–44. doi: <https://doi.org/10.15587/2706-5448.2023.275242>

## 1. Introduction

When drilling oil and gas wells, technical and economic indicators are determined, for the most part, by the efficiency of the rock-destructive tool – mechanical speed and bit penetration [1–3]. Therefore, great attention is always paid to issues of drill string dynamics.

The most realistic way of controlling the dynamics of the drill string is the use of drill string bottom layouts (DSBL) with drilling mode correction devices [1, 4, 5].

Of particular importance is the use of corrective devices to increase well drilling performance. Alignment of bit oscillations generated by the drill string by changing operating parameters makes it possible not only to increase well drilling performance, but also to affect core storage during the trip.

Industrial tests of DSBL correction devices showed their sufficiently high efficiency [6–8].

Therefore, it is relevant to study the processes occurring in the drill string during well drilling.

Thus, the dynamic processes occurring in the drill string during the hole deepening in deep wells were chosen as the *object of research*. And the *aim of research* is to study the longitudinal and torsional oscillations when adjusting the axial load on the bit by using a screw mechanism.

## 2. Materials and Methods

The work uses the method of mathematical modeling of a mechanical system. Variants of connecting the correcting device as a shock absorber or amplifier of the axial load are studied. For research, a correction device is used, in which a screw mechanism is used.

## 3. Results and Discussion

When drilling oil and gas wells, technical and economic indicators are determined, for the most part, by the efficiency of the rock-destroying tool – mechanical speed and bit penetration [9].

The design of the correction device is shown in Fig. 1. It consists of a body 4 connected to a lower part 12, which has an internal multi-turn non-self-locking thread. A hollow screw 11 is screwed into the nut, which is connected to the barrel 2. A washer 10 is screwed onto the barrel, on which a thrust bearing 9, a lower piston 8, and a thin-walled shell 6 are mounted. The volume between the barrel and the wall of the shell is filled with an elastic filler 7, for example, made of IRP-1124 rubber. On the other side, the upper piston 5 is inserted, which rests on the upper guide.

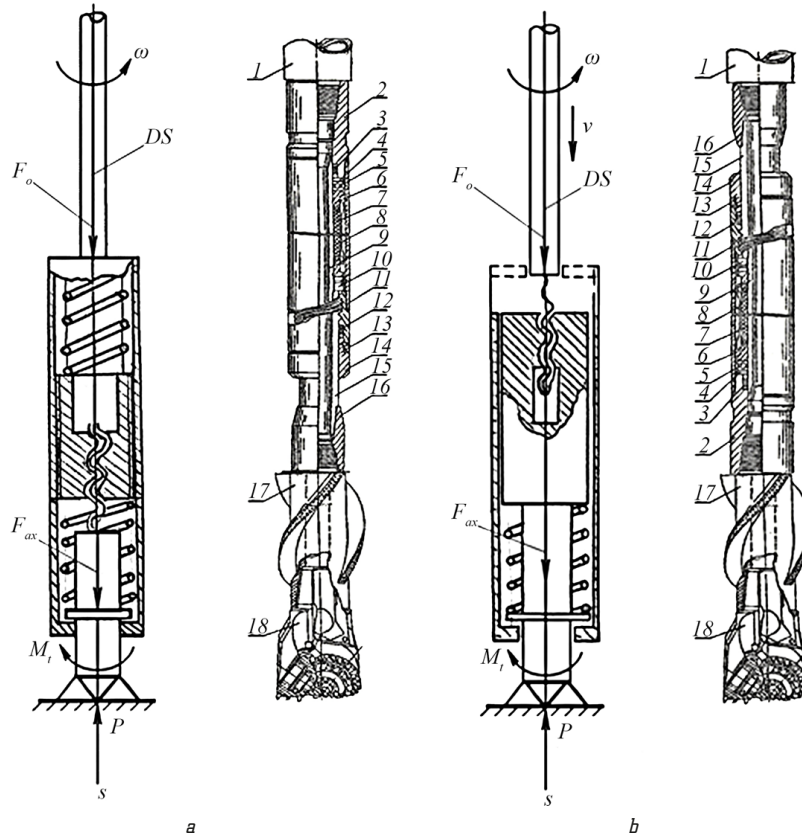

**Fig. 1.** Corrective device and scheme of axial load caused by torque: *a* – shock absorber; *b* – screw amplifier; 1 – drill string (DS); 2 – adapter; 3 – screw; 4 – packing nut; 5 – nut; 6 – oil seal; 7 – body; 8 – puck; 9 – barrel; 10 – shell; 11 – filler; 12 – piston; 13 – bearing; 14 – puck; 15 – oil seal; 16 – adapter; 17 – blade spiral calibrator (BSC); 18 – bit

The threaded adapter connects to the body 4 and has a thread in the upper part to the shaft of the downhole motor or the drill string. The proposed device can be used as a shock absorber or amplifier of the axial load on the bit. In the case of using the device as an amplifier, the drive shaft is connected by a thread through the converter 17 to the screw 11. In the case of using the device as a shock absorber, a chisel is attached to the converter 1 on the thread. The options for connecting the device are shown in Fig. 2 [9].

When using the device as an amplifier of the axial load due to the power of the torque transmitted from the rotor or the shaft of the reciprocating engine, the screw is screwed into the nut and through the support bearing and piston acts on the elastic element and elastically deforms the shell, which elastically deforms. Thus, through the shell shock absorber, the axial force from the screw is transmitted to the bit through the housing and the lower guide.

Depending on the value of the torque, the value of the axial load on the bit changes. Let's consider the effect of changing the main parameters on the operation of the screw mechanism and their effect on the value of the axial load.

The main parameters of the screw mechanism include the average diameter and the angle of elevation of the thread. Important parameters are also the step and number of thread steps and the screw stroke [10–12].

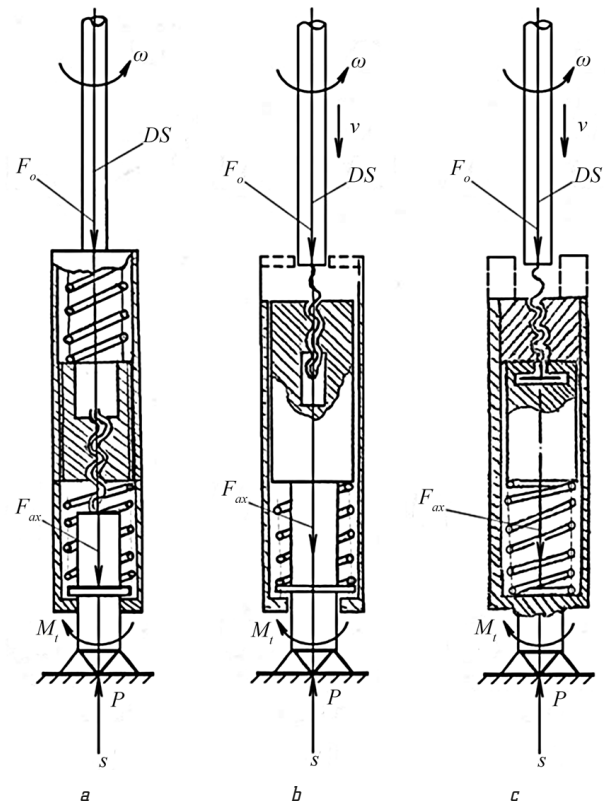

**Fig. 2.** Options for connecting the correction device: *a* – as a shock absorber; *b, c* – as an amplifier of the axial load

In the proposed correction device, a hollow screw is used, the average thread diameter of which is determined according to [11]:

$$d_{av} = 2 \sqrt{N \frac{k_1 k_2 k_3}{k_4 \pi [\sigma]}}, \quad (1)$$

where  $N$  – axial load;  $k_1$  – coefficient of reduction of the screw cross-section along the inner diameter,  $k_1=1.1-1.15$ ;  $k_2$  – coefficient of permissible overload,  $k_2=2.0-3.0$ ;  $k_3$  – coefficient of uneven distribution of the load on turns,  $k_3=1.1-1.15$ ;  $k_4$  – coefficient of complex stress state and stress concentration in the section,  $k_4=0.8-0.9$ ;  $[\sigma]$  – allowable compressive stress of the screw material, for 40XH steel  $[\sigma]=40-42$  kN/cm<sup>2</sup>.

Taking into account the values of these coefficients, let's obtain:

$$d_{av} = 0.98 - 1.19 \sqrt{N} \approx 0.1 \sqrt{N} \text{ kH}. \quad (2)$$

The elevation angle of the screw thread is assumed to be non-self-braking (the angle of elevation of the thread is greater than the angle of friction). The axial force that loads the screw causes significant friction on the cutting surface, which must be overcome by the driving torque. Let's consider a simple case with the use of a rectangular thread in the adjusting mechanism. Fig. 3 shows the scheme of the mechanism, which is loaded with an axial force  $Q$  – the thread is rectangular, right-hand, with the elevation angle  $\alpha$  and the average radius of the thread  $r_{av}=d_{av}/2$ . When rotating the drill string or the drive shaft of the drilling motor, which is connected to the screw of the device, to increase the axial load, the screw is screwed into the nut, and through the bearing, the axial force is transmitted through the filler, which elastically deforms the cylindrical elastic shell (diaphragm). The axial load is transmitted to the bit through the lower piston and through the body. When rotating the screw in the direction indicated in the figure (to move in the direction of the force, i. e. downward), it is necessary to spend some moment, which let's denote by  $M_m$ . Let's determine the dependence for this moment taking into account  $Q$ ,  $r_{av}$  and  $f$  (friction coefficient on the thread). Let's suppose that the drill string or the shaft of the drilling motor rotates at a certain moment of time at a constant speed, which gives the basis for the equation of motion to be presented in the form of the equation of work:

$$A_{pd} = A_{pd} + A_{fr}, \quad (3)$$

where  $A_{pd}$  – the operation of the power drive;  $A_{fr}$  – work of friction forces.

The driving factor is  $M_m$  the useful resistance of the longitudinal force of other forces applied to the screw from the side of the bit nut and the friction of the device body with the well wall  $\delta F$ , because the forces of normal reaction will not do the work.

Let's determine the work of frictional forces  $\delta F$  by the movement corresponding to one revolution of the screw. In this case,  $M_m$  will be performed a work at the angle of rotation  $2\pi$ , and the force  $Q$  will be performed along the path  $h=zt$  equal to the screw stroke, and at the same time proportional to the pitch of the helical

line of the thread. The path of the points of application of force  $\delta F$  will be given by the sum of the lengths of the turns that are engaged with the turns of the nut. For a one-way thread, such a path will be represented by the length of the turn  $l$ . Then, after substitution, let's obtain for a one-way thread:

$$M_m 2\pi = Qh + \sum \delta F l, \quad (4)$$

and for a multi-way thread (4) it will be written:

$$M_m 2\pi = Qzt + \sum \delta F l_i, \quad (5)$$

where  $z$  – the number of ways;  $t$  – thread pitch;  $h=zt$  – screw stroke.

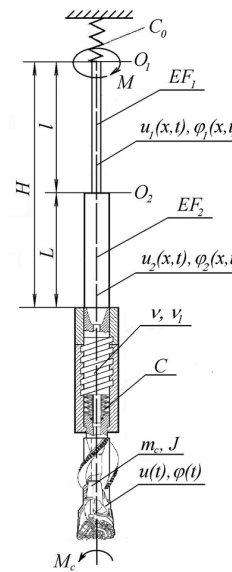

**Fig. 3.** Scheme of the device load caused by the torque and axial load caused in the drilling process

In the future, let's consider the operation of a device with a one-way thread.

For a one-way thread, it is possible to write [11]:

$$h = 2\pi r_{av} \tan \alpha \quad \text{and} \quad l = \frac{2\pi r_{av}}{\cos \alpha},$$

substituting these expressions in (4), let's obtain:

$$M_m 2\pi = Q 2\pi r_{av} \tan \alpha + \sum \delta F \frac{2\pi r_{av}}{\cos \alpha}, \quad (6)$$

or

$$M_m = r_{av} \left( Q \tan \alpha + \frac{\sum \delta F}{\cos \alpha} \right). \quad (7)$$

Given that there is sliding friction  $\delta F = f \delta R_n$ . To exclude  $\delta R_n$ , let's formulate the conditions of uniform movement of the axis  $z$  screw in the form of the sum of force projections on the axis:

$$-Q + \sum f \delta R_n \cos \alpha - \sum \delta F \sin \alpha = 0. \quad (8)$$

Substituting  $\delta F$  through  $f \delta R_n$  and solving the above equations, after a series of transformations and definitions, let's obtain the equations in the final equation:

$$M_m = Q r_{av} \tan(\alpha + \rho). \quad (9)$$

Let's determine  $M_m$  when using different bit drives – rotary, electric drive, turbine, screw engine.

With the rotary method of drilling, deepening of the hole with a bit is carried out due to the rotary and translational movement of the drill string with a defined layout and taking into account the operation of the bit with the column and the hole. The given kinetic energy is developed by the working parts of the process when the column  $\varphi_k$  is moved at an angle under the action of the average torque during the downward movement  $M_d$  and the moment  $M_G$  that arises due to the axial load:

$$T_k = (M_d + M_G)\varphi_k\eta_k = \frac{j\omega_k^2}{2}, \quad (10)$$

$$M_G = \frac{Gh}{2\pi}, \quad (11)$$

where  $G$  – the force of the weight of the drill collar part, which determines the axial load on the bit.

The angles  $\varphi_m$  and  $\varphi_d$  of rotation of the drill string and the screw, which ensure the interaction of the weapon, the tooth of the bit with the rock, corresponding to the linear movements of the screw  $s_m$  and  $s_d$ :

$$\varphi_p = \varphi_m + \varphi_d = \frac{2\pi}{h}(s_m + s_d), \quad (12)$$

where  $\varphi_p = \frac{2\pi}{h}s_p = k\frac{2\pi}{h}s_m$  ( $k=0.7-1.0$ ).

Then the required average value of the torque will be during the movement of the screw down to the bit:

$$M_d \geq \frac{T_e}{k\varphi_m\eta} + M_G = \frac{T_e h}{k2\pi s_p \eta} + M_G. \quad (13)$$

Drill collar has a large reserve of kinetic energy and momentum  $M_G$  that is always sufficient to overcome friction.

With the rotary method of drilling with a downhole drive, the drill string consists not only of drill pipes and a bit, but it also includes an engine that is located above the downhole. Therefore, in order to fully characterize the operation of all elements that participate in deep drilling and their relationship, it is necessary to characterize the bit drives, drilling engines and their mechanical characteristics.

The moment on the bit, necessary for drilling the rock with a ball bit, is in a complex functional dependence on the parameters that characterize the design of the bit, the mechanical properties of the rock, the angle of curvature of the well, as well as on the load and speed of rotation of the bit. If only the load  $P$  and the speed of rotation of the bit are taken as variables, and all other factors for a specific case are constant, then the moment on the bit can be written in the simplest form [13]:

$$M_r = M_{sp}P, \quad (14)$$

where  $M_{sp}$  – specific moment;  $P$  – axial load on the bit.

The moment on the bit, with the turbine method of drilling, is determined by the dependence [13]:

$$M_d = M_T \left(1 - \frac{n_p}{n_x}\right) + M_{sp}P, \quad (15)$$

where  $n_p = n_x$  – neglecting the frictional forces in the layer support.

The resulting formula for the torque of a screw engine has the form [14]:

$$M = M_0 p Det, \quad (16)$$

where  $e$  – the eccentricity to the engagement tooth radius  $r$ ; the specific moment  $M_0$  is expressed as:

$$M_0 = \frac{z_2 - 1}{2} + \frac{2}{\pi C_e}, \quad (17)$$

where  $z_2$  – the number of rotor steps;  $C_e$  – the dimensionless parameter.

Let's determine the order of change of the axial load when using a screw amplifier for different drilling methods.

Substitute (10) and (11) into (13) and after a series of transformations let's obtain for rotary drilling:

$$P \leq \frac{\left(M_d + \frac{Gh}{2\pi}\right)\varphi_p}{2\pi k s_m M_{sp}} + \frac{Gh}{2\pi}. \quad (18)$$

To determine the moment on the shaft of the screw engine, let's use relations (16) and (17) and the general equation (9). After substitution and a number of transformations, let's obtain:

$$Q = \frac{M_0 p Det}{\frac{d_{av}}{2} \tan(\alpha + \rho)}. \quad (19)$$

It is known from the theory of similarity of turbines [15] that the value of the torque can be written as:

$$M = A_M n^2 D^5 \gamma, \quad (20)$$

where  $n$  – the number of revolutions of the turbine;  $D$  – calculated diameter;  $\gamma$  – density of washing solution;  $A_M$  – proportionality coefficient (quantity, constant for this regime and dependent on the kinematic scheme of the flow part).

Substituting expression (20) into equation (9) and after transformation let's obtain:

$$Q = \frac{A_M n^2 D^5 \gamma}{\frac{d_{av}}{2} \tan(\alpha + \rho)}. \quad (21)$$

The change in the axial load on the bit during turbine drilling can be recorded using the relationship (15).

The given dependencies must be clarified taking into account the time-varying axial load and torque depending on the change in the geological and technical conditions of drilling and the drill string pile.

#### 4. Conclusions

1. The axial load screw working mechanism creates a relationship between the axial load on the bit and the torque on the screw. This makes it possible to install safety devices that limit the torque of the drive shaft (reciprocating engine, rotor).

2. Different types of energy supplied to the punch, which are converted by the punching motor and ampli-

fied by the axial (screw) amplifier installed above the bit, provide rotary-progressive movement of the chip bit and increase the drilling performance.

3. The obtained dependencies take into account the change in time of the axial load and torque depending on the parameters of the axial amplifier and the geological and technical conditions of drilling and the layout of the bottom of the drill string.

### Acknowledgments

The authors express their personal gratitude and sincere gratitude to Doctor of Technical Sciences, Professor Petro Ohorodnikov for his invaluable contribution to the work on the article, and are deeply saddened by his passing away.

### Conflict of interest

The authors declare that they have no conflict of interest in relation to this research, whether financial, personal, authorship or otherwise, that could affect the research and its results presented in this paper.

### Financing

The study was performed without financial support.

### Data availability

The manuscript has no associated data.

### References

- Iunin, E. K. (1983). *Upravlenie nizkочastotnymi kolebaniiami burilnoi kolonni s tseliu povisheniia effektivnosti protsessa bureniia*. Moscow, 367.
- Riane, R., Doghmane, M. Z., Kidouche, M., Tee, K. F., Djezzar, S. (2022). Stick-Slip Vibration Suppression in Drill String Using Observer-Based LQG Controller. *Sensors*, 22 (16), 5979. doi: <https://doi.org/10.3390/s22165979>
- Vaziri, V., Kapitaniak, M., Wiercigroch, M. (2018). Suppression of drill-string stick-slip vibration by sliding mode control: Numerical and experimental studies. *European Journal of Applied Mathematics*, 29 (5), 805–825. doi: <https://doi.org/10.1017/s0956792518000232>
- Surnin, L. S. (1986). *Privishenie effektivnosti primeniia amortizatorov na baze issledovaniia volnovikh protsessov v burilnoi kolonne*. Ivano-Frankovsk, 187.
- Ullah, F. K., Duarte, F., Bohn, C. (2016). A Novel Backstepping Approach for the Attenuation of Torsional Oscillations in Drill Strings. *Solid State Phenomena*, 248, 85–92. doi: <https://doi.org/10.4028/www.scientific.net/ssp.248.85>
- Ogorodnikov, P. I. (1990). *Upravlenie upravleniia zaboia skvazhiny na baze izucheniia dinamicheskikh protsessov v burilnoi kolonne*. Moscow, 423.
- Teifanskii, S. L., Beresnevich, V. I., Oks, A. B. (1991). *Nelineinye i parametricheskie kolebaniia vibratsionnykh mashin tekhnologicheskogo naznacheniia*. Riga: Zinatne, 229.
- Canudas-de-Wit, C., Rubio, F. R., Corchero, M. A. (2008). D-OSKIL: A New Mechanism for Controlling Stick-Slip Oscillations in Oil Well Drillstrings. *IEEE Transactions on Control Systems Technology*, 16 (6), 1177–1191. doi: <https://doi.org/10.1109/tcst.2008.917873>
- Shelepin, E. I., Ogorodnikov, P. I., Surnin, L. S. et al. (1969). A.s. SRSR No. 287858 *Amortizator kolebaniia burilnoi kolonni*. MKI E2V17/06. Declared: 29.09.69, published: 03.12.69, Bul. No. 36.
- Tishchenko, O. F., Kiselev, L. T., Kovalenko, A. P. et al. (1982). *Elementy pribornykh ustroistv. Ch. 1. Detali, soedineniia i poredachi*. Moscow: Vysshiaia shkola, 304.
- Kolchin, I. I. (1972). *Mekhanika mashin. Vol. 2*. Moscow: Mashinostroenie, 454.
- Bocharov, Iu. A. (1976). *Vintovye pressy*. Moscow: Mashinostroenie, 245.
- Allikvander, E. A. (1969). *Sovremennoe glubokoe burenie*. Moscow: Nedra, 228.
- Grigorian, N. A., Bagirov, R. E. (1982). *Analiz protsessu turbinogo bureniia*. Moscow: Nedra, 206.
- Mikhaltcev, V., Moliakov, V. (2020). *Teoriia i proektirovanie gazovoi turbiny*. Moscow: MGТУ im. N. E. Baumana, 230.

✉ **Viktor Svitlytskyi**, Doctor of Technical Sciences, Professor, Department of Oil and Gas Technologies, Engineering and Heat Power Engineering, Odessa National Technological University, Odessa, Ukraine, e-mail: [svitlitsky@gmail.com](mailto:svitlitsky@gmail.com), ORCID: <https://orcid.org/0000-0003-4778-0414>

**Tetiana Sahala**, PhD, Associate Professor, Department of Oil and Gas Technologies, Engineering and Power Engineering, Odessa National University of Technology, Odesa, Ukraine, ORCID: <https://orcid.org/0000-0003-3569-7920>