



**Victor Levit,  
Viacheslav Kamenets,  
Denis Chebotenko**

# EXPERIENCE AND PROSPECTS OF INNOVATIVE MAIN ROADWAYS CONSTRUCTION AND MAINTENANCE TECHNOLOGIES OF NEW COAL UNITS OF PJSC «MINE MANAGEMENT «POKROVSKE»

*The object of research is the proven and promising innovative technologies for the construction and maintenance of main roadways in difficult mining and geological terms of the Private Joint Stock Company (PJSC) Pokrovske Mine Management of Metinvest-Pokrovskvuhillia Group (Ukraine).*

*The problem focused by the research is to ensure the effective innovative and modernized known technologies application of the main roadways construction and maintenance in new coal units. Namely, the roadways and chambers of the shaft yards, long horizontal and inclined main roadways to improve their operational state and technical and economic indicators of mining engineering and extracting operations.*

*Based on the accumulated production experience, the results of the roadways state survey under construction and in operation, analysis of documentation and scientific and technical developments of world scientific institutions, recommendations for the investment projects implementation in terms of construction and mining technologies optimizing had formulated. The recommendations include the introduction of combined support systems adapted to mine management conditions, tunneling equipment of a new technical level of the world's best producers, methods of roadways maintaining by location in oflooded areas, and modern means of Geomechanic situation monitoring. The expected economic benefit of reducing the cost of roadways maintaining may be 20–25 %.*

*The results are summaries of cooperation with the engineering and technical staff of Mine Management Pokrovske and Metinvest Holding.*

*The results can be used in practice now, and more broadly after the victory and the start of economic recovery, including in Ukraine's mining sector.*

**Keywords:** coal unit, investment project, main roadways, roadway construction, maintenance technologies, innovations in mining.

Received date: 11.03.2023

Accepted date: 28.04.2023

Published date: 30.04.2023

© The Author(s) 2023

This is an open access article

under the Creative Commons CC BY license

## How to cite

Levit, V., Kamenets, V., Chebotenko, D. (2023). Experience and prospects of innovative main roadways construction and maintenance technologies of new coal units of PJSC «Mine Management «Pokrovske». *Technology Audit and Production Reserves*, 2 (1 (70)), 35–42. doi: <https://doi.org/10.15587/2706-5448.2023.280103>

## 1. Introduction

Private Joint Stock Company (PJSC) Pokrovske Mine Management is part of Metinvest Pokrovskvuhillia Group and it is the largest coking coal producer in Ukraine and Eastern Europe with reserves of 200 million tons. In 2021, the company produced more than six million tons of raw coal, and in 2022, amid the full-scale Russian aggression and the company's location in the frontline area, production amounted to 5.3 million tons. It is the only coal mining enterprise in Ukraine that carries out mine construction. Unit 10 was constructed and put into operation, and work is nearing completion on Unit 11, where the construction of a 930 m horizon (hor.) shaft yard is being completed and extracting are already underway. In 2021, the construction of coal Unit 12 was launched (suspended in February 2022), where it is planned to sink the skip No. 4

and air feed No. 4 shafts with a depth of 1400 m, as well as large underground and surface complexes. The goal of the project is to maintain the level of coking coal production, which has been in high demand by Ukrainian and foreign consumers since the 1930s [1, 2].

The construction and operation of Block 11 takes place in difficult mining and geological terms, and the depth of mining operations in Unit 12 will reach 1500 m, so it is possible to confidently predict a further increase in the cost of main roadways driving and maintaining. These circumstances make the problem relevant from a scientific and practical point of view.

A dozens of studies have been devoted to the scientific and applied aspects of this problem, in particular in the Pokrovske Geological-Industrial District [3–8]. However, there is an obvious need to summarize the latest production experience and assess the prospects for innovative

technologies in view of the current situation and with the hope of rebuilding and modernizing the Ukrainian mining industry after the victory.

The aim of research is to analyze the experience of applying technologies for the main roadways construction and maintenance at PJSC Pokrovske Mine Management and to assess the prospects for the implementation of innovative solutions in the construction and operation of new coal Units as part of the implementation of current and future investment projects.

## 2. Materials and Methods

The object of research is the current and prospective innovative technologies for the construction and maintenance of main roadways in difficult mining and geological terms of the new Units of PJSC Pokrovske Mine Management. The production and surveying services of Mine Construction Company LLC surveyed the main roadways of Unit 11. The geological, technological, design and investment documentation of the customer and contractors Sviato-Pokrovska Mine No. 3 LLC and Mine Construction Company LLC (formerly Donetskshakhtoprophodka Trust) and modern production experience were analyzed.

## 3. Results and Discussion

The development programs for Units 11 and 12 [1, 2] for the next two decades envisaged the annual driving of up to four kilometers of horizontal and inclined roadways. Half of them will be main roadways, namely, long branches and shaft yard chambers, main drifts, crosscuts, panel inclined entries, etc. The main roadheader and drill-and-blast driving technologies, as in other countries with developed

mining industries, will not change fundamentally for the foreseeable future. In addition, the most commonly used fastening types will remain metal frame support structures in combination with steel-polymer and flexible rope anchors. For the Pokrovske Geological-Industrial District, the best frame support is the KShPU (unified hipped yieldable support) made of heavy special interchangeable profiles (SVP) No. 27 and 33, including stiffening stops. The fencing of the interframe space will be metal mesh or reinforced concrete piece ones continuously with subsequent filling of the voids with grouting solutions after knitting works [9–11].

The volume of main roadways under construction was to gradually decrease within Unit 11 and increase within Unit 12, Fig. 1–3, as underground construction works were deployed in the latter. However, under martial law, when the investment project of Unit 12 is suspended, mining and construction works are concentrated in Unit 11 and in the reserve Unit 1, where the working seam  $d_4$  is categorized as thin and very thin. This is a forced but necessary decision to maintain coal production in the medium term.

Maintaining the stability of main roadways is a very important task during the completion and operation of Unit 11. However, it should be borne in mind that only technologies that have proven to be reliable and economically viable should be used at Unit 12 with a 500-meter deepening.

At depths of about 1000 m and more, even strong rocks, such as sandstone, siltstone and limestone, become unstable, covering large areas, and they are squeezed into the roadways space. At the same time, when the strength of the enclosing rocks seems to be sufficient, the roadway stability begins to deteriorate sharply, and the rock contour displacements increase abruptly.

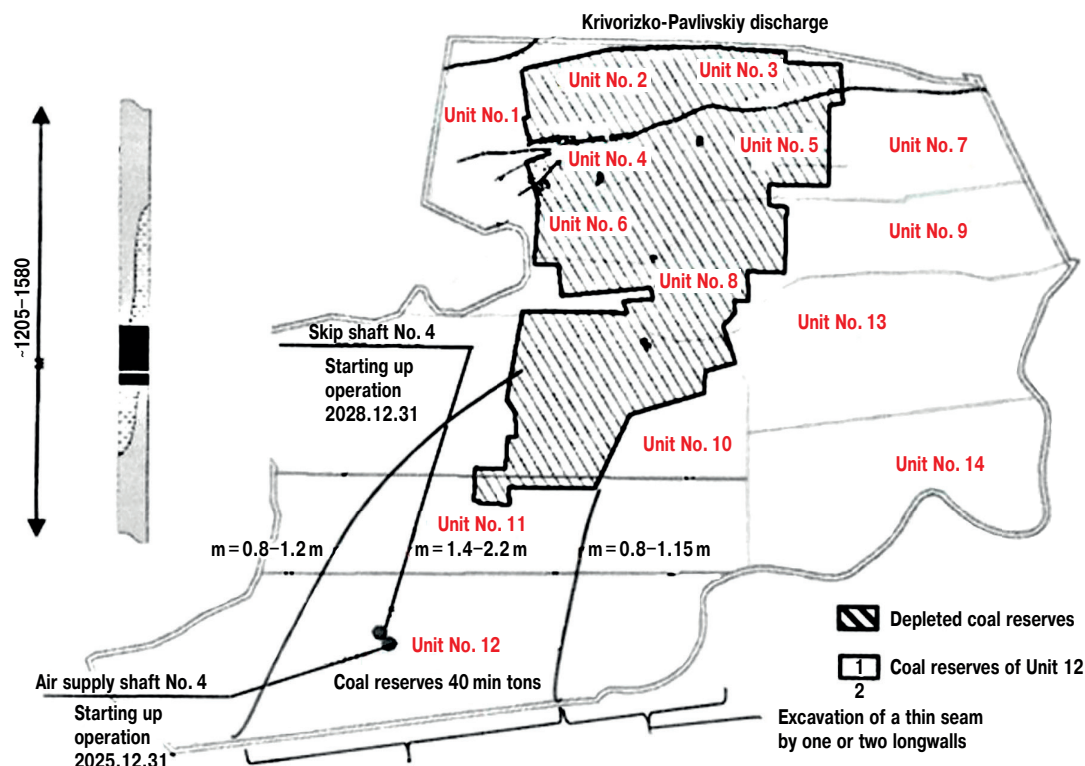
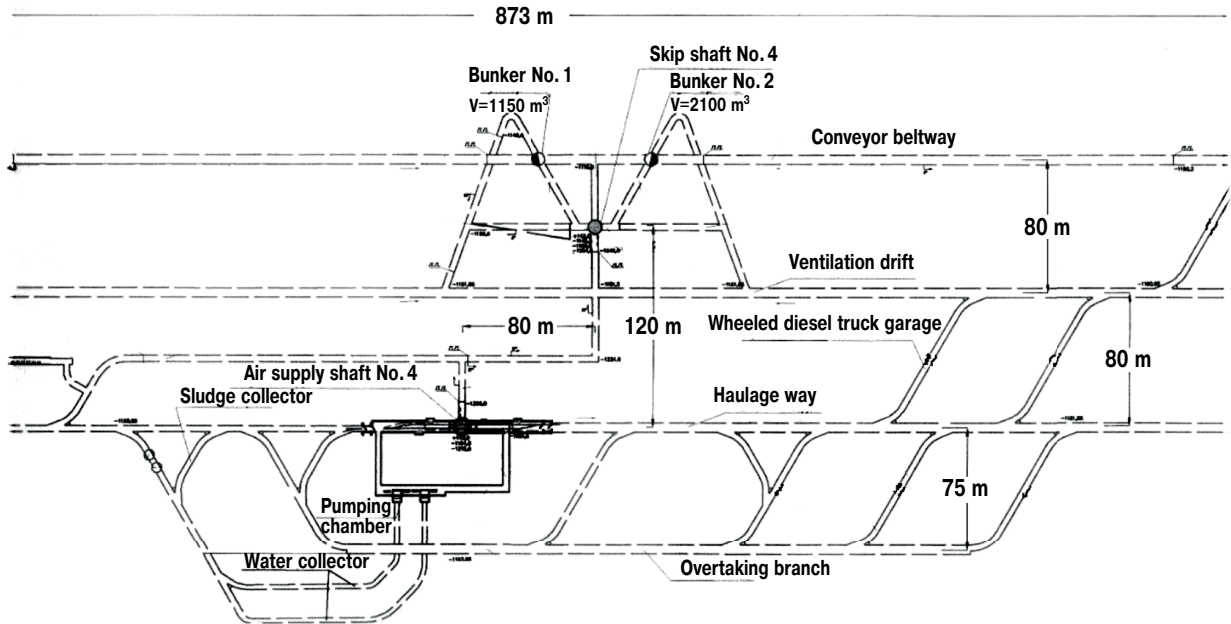
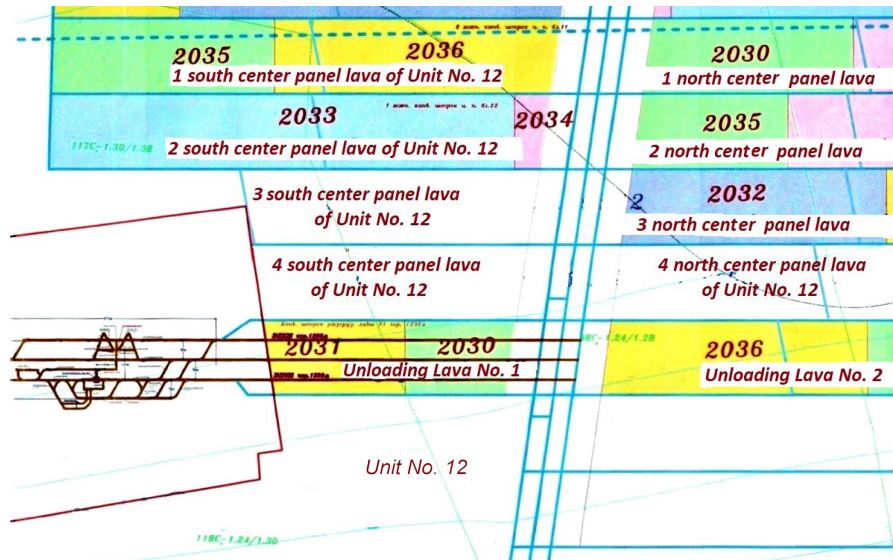

Fig. 1. Scheme of the mining allotment and characteristics of Unit 12



**Fig. 2.** Scheme of the shaft yard of Unit 12



**Fig. 3.** Fragment of reserves mining schedule of Unit 12

Specifically, in the conditions of the Pokrovske Mine Management, according to the survey and observations of the state of the entries, such a negative effect is observed from a depth of 750–800 meters. An example is the shaft yard and other main roadways of the 930 m horizon, Fig. 4–7, where a significant convergence of the rock contour, floor heaving with a continuity fault in strong enclosing rocks is fixed.

Combined frame and anchor fastening structures with subsequent tamponage in various modifications for long entries, junctions and chambers are used, Fig. 8–10. However, for the roadways with a cross-sectional area of about  $40\text{ m}^2$ , namely the cargo and empty branches of the air supply shaft No. 3, a rigid metal ring ovoidal support (MKZO) with a horseshoe-shaped reverse vault was design and constructed, Fig. 11.

This metal and concrete support with rigid reinforcement in a monolith with concrete is a closed oval-shaped structure developed by the State Enterprise (SE) «Luhanskdiiproshakht» for the Pokrovske Mine Management conditions. The rigid reinforcement used is an arch support made of SVP-33 with

stiffening stops, installed along the inner and outer contour of the roadway, with a frame of reinforcing mesh and a tightening mesh. The support of the reverse vault with SVP-33 stiffeners and anchors before concreting, Fig. 12.

Obviously, the main and, probably, other roadways of the next Unit 12 will be constructed with a reverse vault to give the cross-section greater stability at depths of about 1500 m and to prevent floor heaving.

If it is impossible to perform tamponage in the constructed roadways (voids have disappeared, damaged frames and fencing elements), it is effective to use shotcrete to enhance the load capacity of steel frames that have been deformed and corroded [12]. The surface coating with a layer of shotcrete that is an alternative to the very expensive reconstructing process of underground roadway. This technology is simple, fast, relatively cheap and safe, and the relevant equipment and personnel are available at the contractor, Mine Construction Company LLC, which is part of Metinvest Pokrovskvuhillia Group.

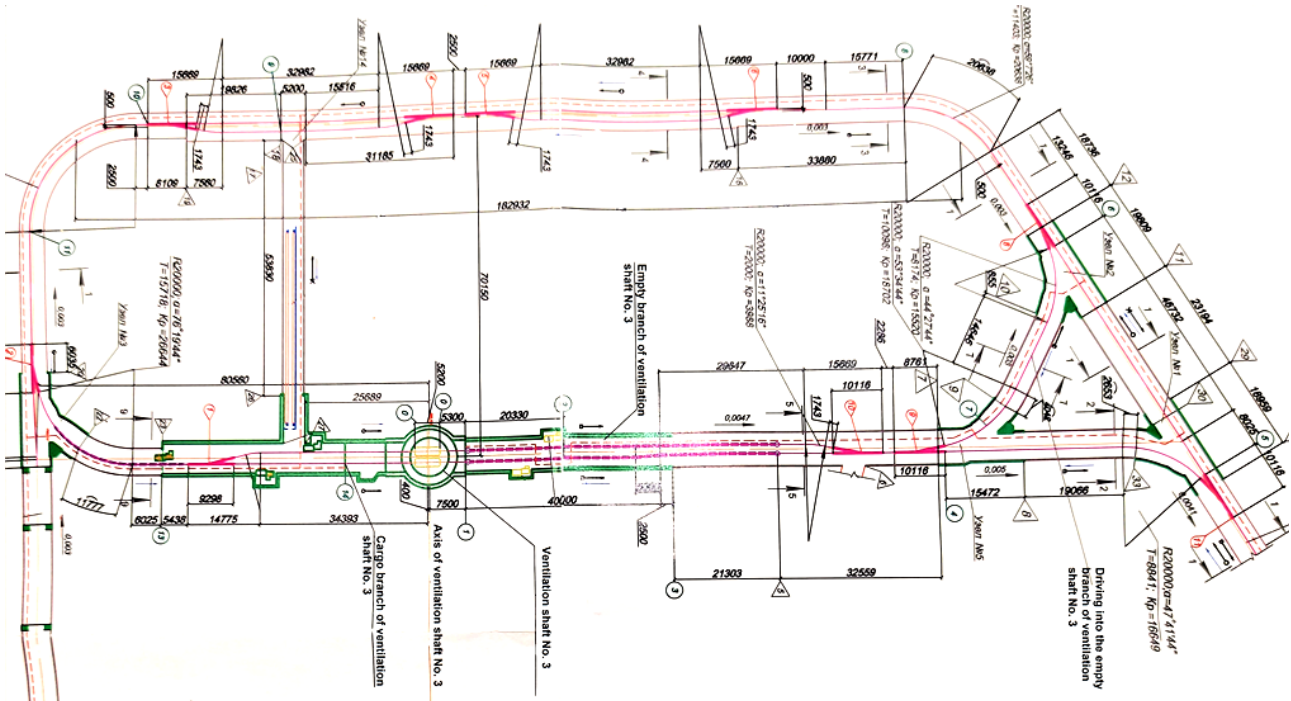

**Fig. 4.** Construction area for cargo and empty shaft yard branches of the 930 m horizon of Unit 11

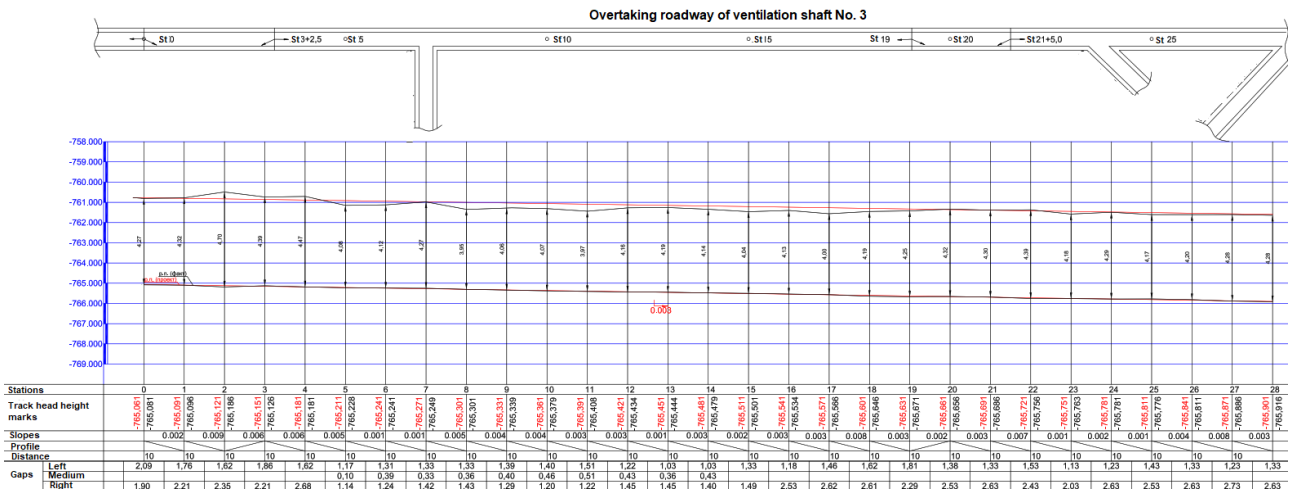

**Fig. 5.** Overtaking roadway floor deformation profiles of the shaft yard 930 m horizon

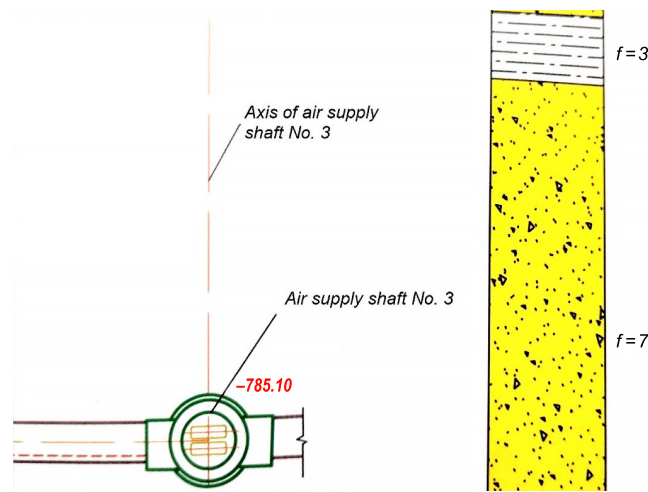

**Fig. 6.** Location of the air supply shaft No. 3 and geological section

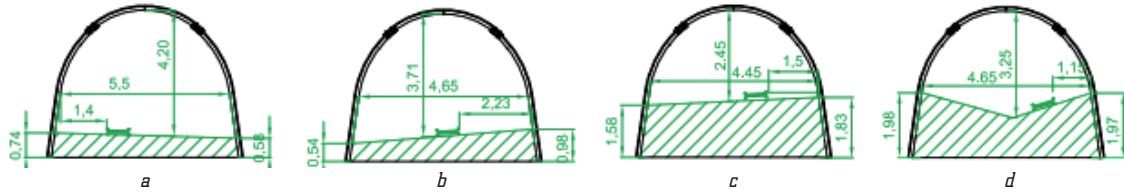

Fig. 7. Roadway floor swelling in hard rocks: a – St 0; b – St 1; c – St 2; d – St 2+4.0

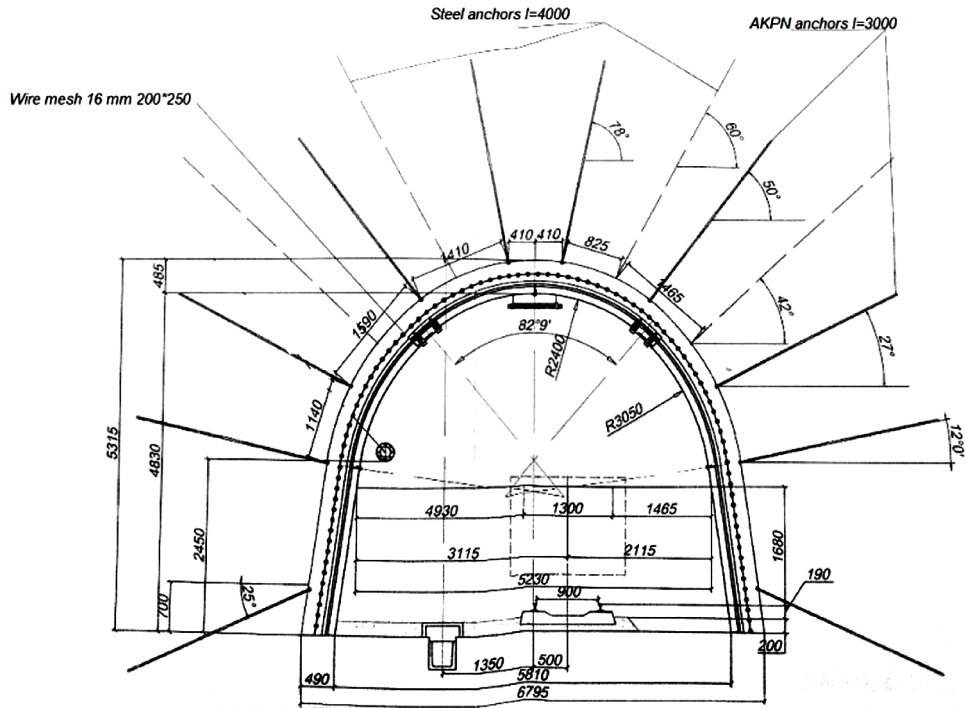

Fig. 8. Combined support for long roadway based on KShP-KD-22 frame with stiffening stops

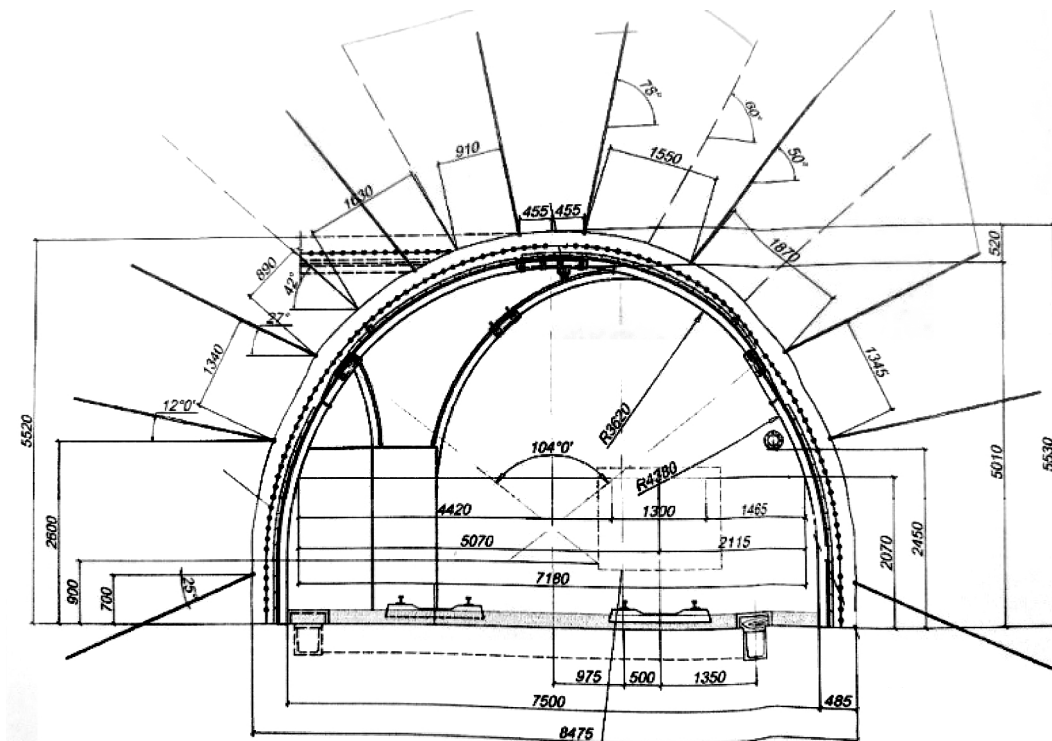
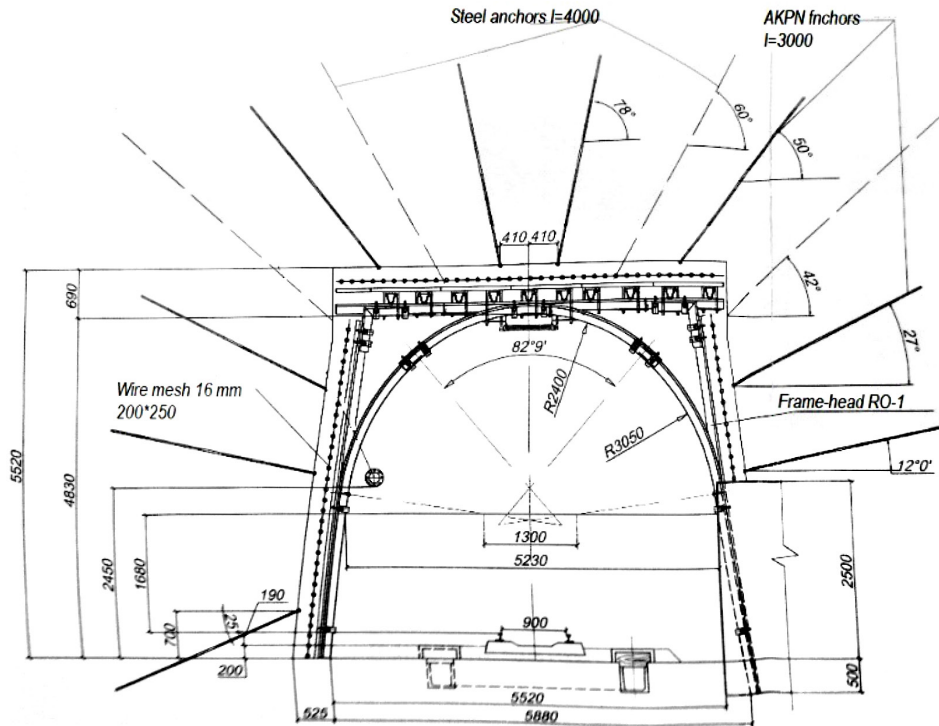
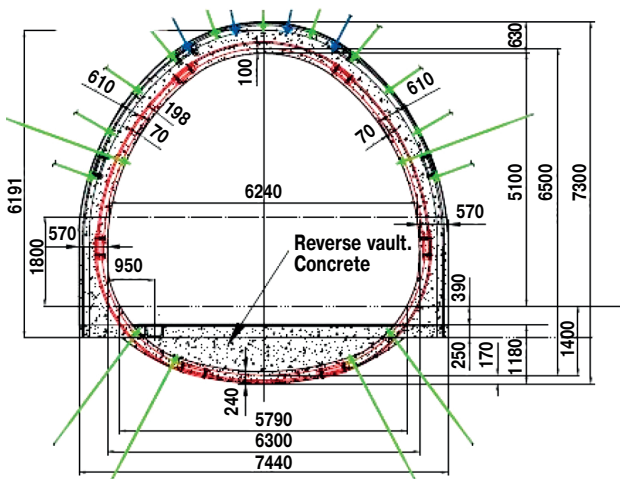

Fig. 9. Combined support for roadway junction based on KShP-KD-22 frame with stiffening stops



**Fig. 10.** Combined enhanced support for long roadway based on KShP-KD-22 frame with stiffening stops



**Fig. 11.** MKZO rigid ovoid support with a horseshoe-shaped reverse vault



**Fig. 12.** Horseshoe-shaped reverse vault and anchors before concreting

The anchoring scheme characterized by mechanical reinforcement of not only the roof rocks, but also the side rock walls to prevent the frame legs being squeeze out into the roadway space.

In addition to the main tunneling machines KSP-42(43), the mine has introduced P-315 super-heavy-type roadheader (105 tons) specially developed for the mine's conditions in cooperation with Novokramatorsk Machine-Building Plant (Fig. 13). However, during operation, design flaws discovered that resulted in insufficient reliability. Developers and manufacturers are working together to solve the problem. In 2022, the use of new EBZ-260 roadheader of the well-known Chinese manufacturer SANYI began and was successful. It is also of the super-heavy-type (85 tons).

Undoubtedly, the main constraint, difficulty and risk in implementing Metinvest Group's large-scale investment projects at Pokrovske Mine Management are the hostilities and martial law resulting from Russia's full-scale aggression. However, all of the holding's assets in the government-controlled territory continue to operate and investments not been suspended, except for Unit 12. The victory will open up prospects for further research and expand the scope of its implementation.

Thus, based on the production experience, visual inspection and surveying observations of the state of long roadways, chambers and junctions, analysis of design and technological documentation, and scientific and technical literature, recommendations for the implementation of investment projects as for introducing innovative and modernizing existing technologies for main development and extracting operations in mine management terms are provided. The recommendations include the main approaches to adapted systems of combined support, the use of roadheader and complexes of a new technical level from leading manufacturers, ways to maintain rock mass stability, and the latest geomechanic systems monitoring means. The expected effect of reducing the cost of maintaining and repairing workings may be 20–25 %.

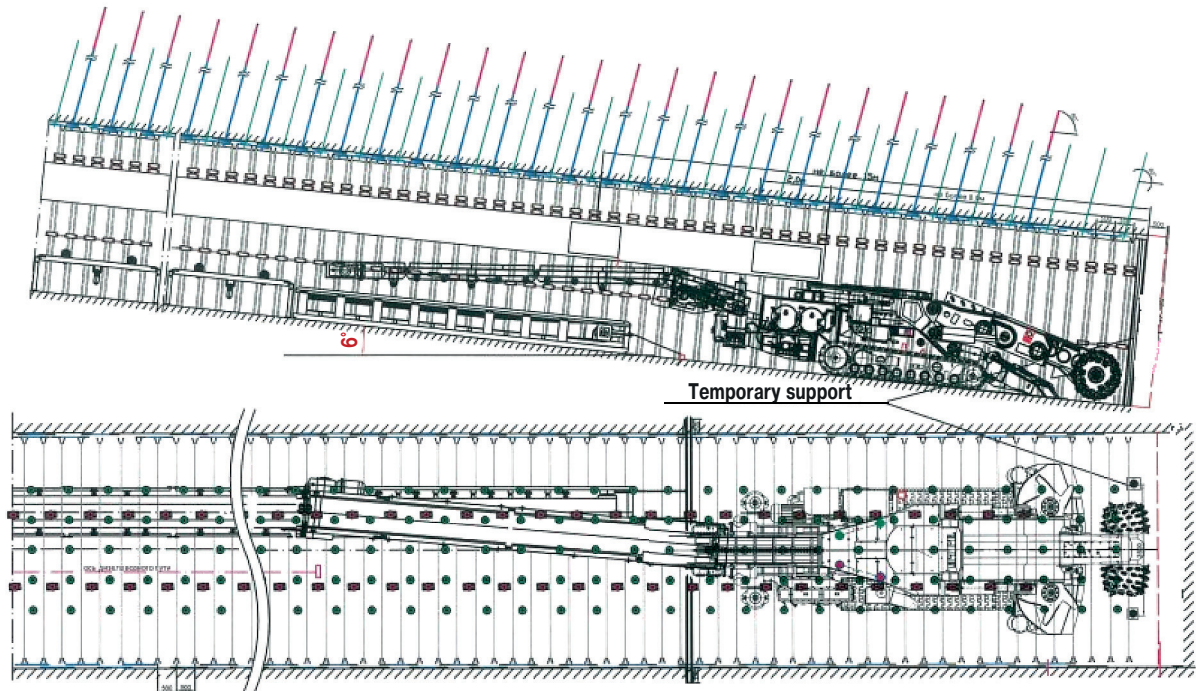

Fig. 13. An inclined roadway driving with a new super-heavy-type roadheader P-315

#### 4. Conclusions

1. It is shown that during the completion and operation of Unit 11 and main roadways maintenance, the situation can be improved by tamping the fastened space using the optimal technology, and if this is not possible, by shotcreting the main roadways surfaces. This is relevant, including outside the shaft yards, as the relevant equipment is available at Mine Construction Company LLC. These measures can be combine with various types of anchoring systems if necessary.

2. When designing the construction of main roadways, attention should be pay to the use of modern means of mechanization for all support types install – frame support, metal rigid support, anchoring, shotcrete support – and driving processes control. High-quality performance of these works certainly affects further stability during operation.

3. The design of support systems in Unit 11 and especially in Unit 12 with a significant increase in the depth of mining operation should take into account the transition of even strong and stable rocks at shallower depths to an unbounded state, the formation of large areas of broken rocks. Let's believe that here it is not possible to do without the use of more stable section forms with a reverse vault and its subsequent reinforcement and grouting, or simply with backfill, which will also provide resistance to floor heaving. This also includes the rationale for the use of closed frame and rigid metal and concrete support structures.

4. The protection of main rock entries by locating them in stress relief zones is an effective and well-tested method, but there is no experience of its application at depths of 1500 m in Pokrovsk geological-industrial district terms. This should be take into account when designing the construction and mining operation of Unit 12.

5. The technologies and equipment for entries driving should be design according to the criteria of efficiency and reliability with preference for domestic developments,

but the cooperation between Pokrovske Mine Management and leading foreign developers and producers should be further evolve. In particular, the experience of the P-315 super-heavy-type roadheader specially designed for the company's conditions was not entirely positive.

6. The design of mine construction and extraction operations should base on existing regulatory documents, well-proven technologies, as well as innovative ones, including pilot operation of experimental scientific and technical developments.

7. It is necessary to develop new regulations to select a technological driving schemes using roadheader and drilling and blasting technology, introduce an observation stations network in constructing entries and new methods of roadway state monitoring using extensometers, bore-scopes, penetrometers, etc.

#### Conflict of interest

The authors declare that they have no conflict of interest in relation to this research, whether financial, personal, authorship or otherwise, that could affect the research and its results presented in this paper.

#### Financing

The research was performed without financial support.

#### Data availability

The manuscript has no associated data.

#### References

1. Proekt «Rozkryttia ta pidhotovka zapasiv bloku No. 11 PrAT «ShU «Pokrovske». Nove budivnytstvo. s. Pishchane, Donetskoï oblasti. Upravlinnia proiektno-vyshukovalnykh robot TOV «ShSP No. 3». Zi zminamy 2022 r.

2. Proekt «Rozkryttia ta pidhotovka zapasiv blokiv No. 12 PrAT «ShU «Pokrovske». Nove budivnytstvo. s. Zelene, Donetskoï oblasti. Upravlinnia proiektno-vyshukuvalnykh robot TOV «ShSP No. 3». Zi zminamy 2021 r.
3. Sdvizhkova, E. A., Kravchenko, K. V., Khalimendik, A. V., Khalimendikov, E. N., Ianzhula, A. S. (2011). Analiz proiavlennii gornogo davlennia pri provedenii protiazhennykh vyrabotok v raione melkoamplitudnykh geologicheskikh narushenii (na primere uklona bloka No. 10 ShU «Pokrovske»). *Naukovi praci UKRNDMI NAN Ukraïni*, 9 (1), 269–281.
4. Kusen, O. B., Nazymko, V. V., Yaitsov, O. O. (2018). Perfection of construction of frame-anchor fastening of joint resistance. *Geo-Technical Mechanics*, 141, 124–133. doi: <https://doi.org/10.15407/geotm2018.141.124>
5. Sakhno, I., Sakhno, S., Kamenets, V. (2022). Mechanical model and numerical analysis of a method for local rock reinforcing to control the floor heave of mining-affected roadway in a coal mine. *IOP Conference Series: Earth and Environmental Science*, 970 (1), 012035. doi: <https://doi.org/10.1088/1755-1315/970/1/012035>
6. Kamenets, V., Kobylianskyi, O., Fedalchenko, M. (2018). Development of the mine workings construction technologies at the Krasnoarmiisk coal industrial area mines. *Innovative Development of Resource-Saving Technologies of Mineral Mining and Processing*. Petroşani: UNIVERSITAS Publishing, 129–131.
7. Solodiankin, A. V., Vygodin, M. A., Kravchenko, K. V., Prokudin, A. Z. (2016). Obosnovanie ratsionalnykh parametrov tekhnologii tamponazha zakrepnogo prostranstva. *Visti Donetskogo gimnichogo institutu*, 1, 22–29.
8. Nazimko, V. V., Iliashov, M. A., Iaitcov, A. A., Demchenko, A. I. (2007). Sovershenstvovanie kombinirovannoi ramno-ankernoï krepï podgotovitelnykh vyrabotok. Razrabotka rudnykh mestorozhdenii. *Trudy KGTU*, 91, 76–79.
9. Kang, H. (2014). Support technologies for deep and complex roadways in underground coal mines: a review. *International Journal of Coal Science & Technology*, 1 (3), 261–277. doi: <https://doi.org/10.1007/s40789-014-0043-0>
10. Solodyankin, O., Hapieiev, S., Vygodin, M., Yanko, V. (2017). Energy Efficient Technologies to Support Mine Workings under Complicated Geomechanical Conditions. *Advanced Engineering Forum*, 25, 35–42. doi: <https://doi.org/10.4028/www.scientific.net/aef.25.35>
11. Myasnikov, I. V., Hapieiev, S. M., Vygodin, M. O., Prokudin, O. Z. (2018). New types of interframe walls for load-bearing strength increasing of main mine workings support. *Bridges and Tunnels: Theory, Research, Practice*, 13, 67–74. doi: <https://doi.org/10.15802/bttrp2018/151908>
12. Ficek, P., Kuczowicz, K., Wróbel, S., Rotkegel, M. (2019). Load Capacity of steel arches with shotcrete coating. *E3S Web of Conferences*, 133, 02006. doi: <https://doi.org/10.1051/e3sconf/201913302006>
13. Dyczko, A., Kamiński, P., Jarosz, J., Rak, Z., Jasiulek, D., Sinka, T. (2021). Monitoring of Roof Bolting as an Element of the Project of the Introduction of Roof Bolting in Polish Coal Mines – Case Study. *Energies*, 15 (1), 95. doi: <https://doi.org/10.3390/en15010095>

---

**Viktor Levit**, Doctor of Technical Science, Professor, Department of Geotechnical Engineering, Donetsk National Technical University, Pokrovska, Ukraine, ORCID: <https://orcid.org/0009-0001-2980-5879>

✉ **Viacheslav Kamenets**, PhD, Associate Professor, Department of Mining, Technical University «Metinvest Polytechnic», Zaporizhzhia, Ukraine, e-mail: [viacheslav.kamenets@mipolytech.education](mailto:viacheslav.kamenets@mipolytech.education), ORCID: <https://orcid.org/0000-0001-8169-2544>

**Denis Chebotenko**, Mining Engineer, Deputy Production Director, Mine Construction Company LLC, Pokrovska, Ukraine, ORCID: <https://orcid.org/0009-0005-3915-7800>

✉ Corresponding author