



Sviatoslav Kavyn,
Bohdan Kavyn

DEVELOPMENT OF A MODEL FOR COLORING RASTER ELEMENTS BASED ON DETERMINING THE CONTRAST OF COLORED RASTER POLYNOMIALLY TRANSFORMED DIGITAL IMAGES

The object of research is the technological process of pre-printing adjustment of image tone reproduction based on the determination of the contrast of colored raster polynomially transformed digital images.

One of the significant problems in the process of pre-printing image preparation is the absence of an automated zonal ink supply adjustment system in most offset machines. Accordingly, this makes it impossible to determine the optimal ink layer to ensure high-quality tone reproduction. Therefore, the urgent task of determining the contrast of colored raster polynomially transformed images over the entire tone reproduction interval arises.

The research process is based on the use of the method of mathematical transformation, the theory of digital image processing and object-oriented programming.

Rasterization algorithms have been developed based on the use of polynomial transformation of digital images of light tones. The result of raster transformation is the determination of the relative area of the coloring of raster elements, which is the main carrier of information about the tonality of the image.

A structural diagram of a contrast simulator of colored polynomially transformed images was constructed, with the help of which the characteristics of coloring of raster elements and the characteristics of the contrast of colored polynomially transformed images were constructed.

The proposed coloring model describes the dependence of coloring of raster elements on the change in the relative contrast of colored raster polynomially transformed images. It is proved that an increase in the thickness of the ink layer increases the initial contrast by +0.2 units. Therefore, changing the thickness of the ink layer can ensure optimal visual image quality due to a change in contrast, which is an advantage of the model.

The research results can be recommended for use in pre-printing processes of adjusting digital images.

Keywords: polynomial transformation, raster transformation, coloring, relative contrast, simulator, quantitative assessment.

Received: 09.01.2026

Received in revised form: 12.04.2026

Accepted: 23.04.2026

Published: 29.05.2026

© The Author(s) 2026

This is an open access article

under the Creative Commons CC BY license

<https://creativecommons.org/licenses/by/4.0/>

How to cite

Kavyn, S., Kavyn, B. (2026). Development of a model for coloring raster elements based on determining the contrast of colored raster polynomially transformed digital images. *Technology Audit and Production Reserves*, 3 (2 (89)), 6–12. <https://doi.org/10.15587/2706-5448.2026.359690>

1. Introduction

In printing, the main method of processing and adjusting digital images is the power (gamma) transformation, in which the phenomenon of posterization occurs when reproducing dark tones of images, which is its disadvantage [1, 2]. In the publication [3], a new polynomial transformation of digital images was developed, which eliminates posterization, which is its advantage. Modern raster processors (RIP) and available software packages for processing graphic information do not provide the functionality of constructing gradation characteristics and raster transformation characteristics [4, 5]. This does not allow analyzing the properties of polynomially transformed digital images and tone reproduction of raster printed images. In this context, it should be noted that most domestic offset printing machines do not have the functionality of automated provision of metered local ink supply, respectively, the process of applying ink to raster elements is carried out manually. Therefore, the thickness of the ink layer applied in this way

largely depends on the experience of the operator who prepares the image for printing and the results of densitometric measurements on the test print. This method is inaccurate and worsens the quality of printed images [6, 7]. Therefore, the actual task of analyzing and determining the relative contrast of colored raster polynomially transformed digital images when changing the thickness of the ink layer in the tone reproduction interval naturally arises.

Contrast determines the ratio of tones in the dynamic range of tone reproduction and describes the visual reaction to a light brightness image. Depending on the purpose and task of assessing the quality of reproduction and tone reproduction, contrast is determined in gray levels.

And stretching the range of gray levels of a digital image helps to enhance contrast, which ensures an increase in the visual quality of the print. Accordingly, determining the relative contrast of inked raster polynomially transformed digital images at the stage of pre-printing preparation is an important component in determining the optimal thickness of the ink layer applied to raster elements. This significantly

expands the capabilities of the operator of computer publishing systems, the technologist and the printer when preparing images for printing and adjusting the inking device for a given print run in order to ensure the visual quality of the print.

Accordingly, based on the justification of the relevance of the problem, the object of research was determined and the aim of research was formed, in particular:

The object of research is the technological process of pre-printing correction of tone reproduction of digital images based on determining the contrast of inked raster polynomially transformed digital images.

The aim of research is to develop a model of inking raster elements to optimize the process of applying a layer of ink, based on determining the contrast of raster polynomially transformed digital images.

The ways to achieve the specified research aim are based on solving the following tasks in the established sequence:

1) to develop algorithms for rasterizing digital images of light tones, corrected using polynomial transformation, to determine the relationship between the relative contrast of the image and the thickness of the ink layer applied to the raster elements;

2) to build a structural diagram of a simulator of the contrast of colored raster polynomially transformed digital images to determine the optimal coloring parameters (the area of raster elements and the amount of ink applied to them);

3) to calculate and construct gradation characteristics of polynomially transformed digital images, characteristics of coloring of raster elements when changing the thickness of the ink layer and characteristics of the relative contrast of the colored raster polynomially transformed image for different thicknesses of the ink layer.

2. Materials and Methods

The following methods were used in the research:

– *Methods of mathematical transformations* in the development of algorithms for rasterizing digital images of light tones, corrected using polynomial transformation, to determine the dependence of the relative contrast of the image and the thickness of the ink layer applied to the raster elements.

For image processing, a mathematical apparatus is used that is based on various mathematical transformations depending on the tasks set. In particular, in printing, power transformation is widely used, but it has certain limitations in obtaining visual image quality, therefore, in the rasterization process, it is advisable to consider the use of polynomial transformation. Since the information carrier is the relative area of raster elements, this makes it possible to form various algorithms for raster image transformation, in particular, based on determining the dependence of relative contrast on the applied ink layer. In this context, it is important to note that there are several dozen different classes of expressions for determining the contrast functions of image elements. Accordingly, this makes it possible to determine the contrast of different image models, correct and synthesize tone reproduction in different systems.

– *Object-oriented programming* in the development of a simulator for simulating the coloring of raster elements based on determining the contrast of raster polynomially transformed digital images to ensure the quality of tone transmission.

In the process of raster conversion, the visual quality of images is determined by such parameters as gradation characteristic, integral (optical) density, contrast sensitivity, which is interdependent. Therefore, for the implementation of simulation modeling of this process, it is advisable to use object-oriented programming, which makes it possible to build a simulator for coloring raster elements when determining the contrast of raster polynomially transformed images. The functional property of which is to establish the dependence of the relative contrast of the image on the coloring of raster elements based on the construction of gradation characteristics and characteristics of raster conversion

of images. Accordingly, this approach makes it possible to determine the optimal parameters for applying an ink layer to raster elements in accordance with their relative area to ensure high-quality tone transmission and obtain a visually high-quality print.

– *The theory of digital image transformation* when performing rasterization of digital images and constructing the characteristics of the coloring of raster elements when changing the thickness of the ink layer and the contrast characteristics of the colored raster polynomially transformed images.

There are various methods of image transformation: spatial, geometric and affine, discrete unitary, Fourier transform, Hara transform, morphological operations, linear and nonlinear filtering, and others. But they cannot be used directly in printing. Processing and transformation in printing has its own specificity, which is reduced to improving the visual quality of printed images. Therefore, appropriate methods and methods of transformation are used to prepare images for printing: gradation correction, histogram analysis, image filtering, nonlinear correction, frequency correction, contrast enhancement. The most frequently used spatial method of image presentation, which is used in computer graphics; in particular, it is presented by a matrix of pixels that quite clearly correspond to the tone intensity of individual elements. Accordingly, this makes it possible to determine the optimal parameters of relative contrast, which directly depend on the gradation characteristics.

The simulation was carried out in the interactive software environment MATLAB (The MathWorks, USA), version 9.7 (R2019b), using the Simulink 10.0 package (The MathWorks, USA) [8]. Hardware parameters: OS: Windows 11, CPU: 6 cores, RAM: 16 GB, Storage: 4–6 GB, GPU: 8 GB.

The simulation process used ready-made operational blocks and functions of the Simulink library. A detailed description of the simulator for simulating the coloring of raster elements based on determining the contrast of raster digital images of light tones, corrected using polynomial transformation, is presented, based on MATLAB: Simulink operators.

3. Results and Discussion

3.1. Development of algorithms for rasterizing digital images of light tones, corrected using polynomial transformation

The definition of the relative contrast of a colored raster image is generally given by the expression

$$K = \frac{(V_1 - V_0) \cdot 1.5}{V_1 - V_0}, \quad (1)$$

where V_1 – the colored specified raster transformation that describes the ink amount on the surface of the raster elements; V_0 – the colored linear scale; 1.5 – the correction factor.

To study the dependence of the influence of the applied ink layer on the raster elements and the contrast of raster polynomially transformed digital images, typical variants of the normalized polynomial transformation were used. In particular, when processing digital images of light tones [3, 9]:

$$L_1 = \frac{2 \cdot L_0}{L_0 + 0.3} \cdot 0.65; \quad (2)$$

$$L_2 = \frac{2 \cdot L_0}{L_0 + 0.5} \cdot 0.75; \quad (3)$$

$$L_3 = \frac{2 \cdot L_0}{L_0 + 0.8} \cdot 0.9; \quad (4)$$

$$L_4 = \frac{2 \cdot L_0}{L_0 + 1.3} \cdot 1.5; \quad (5)$$

if $0 \leq L_0 \leq 1$, then $0 \leq L_i \leq 1$, where L_i – the normalized polynomial transformation; L_0 – the linear scale.

Based on the application of polynomial transformation, the rasterization of typical variants of polynomially transformed digital images was carried out. As a result of the transformation, expressions were obtained for determining the relative area of raster elements, which is a rasterization algorithm [3]:

$$S_1 = 1 - \frac{2 \cdot L_0}{L_0 + 0.3} \cdot 0.65; \quad (6)$$

$$S_2 = 1 - \frac{2 \cdot L_0}{L_0 + 0.5} \cdot 0.75; \quad (7)$$

$$S_3 = 1 - \frac{2 \cdot L_0}{L_0 + 0.8} \cdot 0.9; \quad (8)$$

$$S_4 = 1 - \frac{2 \cdot L_0}{L_0 + 1.3} \cdot 1.5; \quad (9)$$

$$\text{if } 0 \leq S_0 \leq 1, \text{ then } 0 \leq S_i \leq 1, \text{ where } S_0 = 1 - L_0, \quad (10)$$

in which the raster transformation S_0 of the linear scale L_0 is defined for comparison.

The use of the developed variants of raster transformation of digital images of light tones, corrected using polynomial transformation, makes it possible to determine the optimal values of the parameters of the coloring of raster elements to ensure high-quality tone reproduction of the print. Such parameters include, in particular: the relative area of the raster elements and the amount of ink applied to the raster elements.

3.2. Construction of a simulator of coloring of raster elements when determining the contrast of raster polynomially transformed images

If it is about increasing the requirements for the quality of the printed image, then for additional correction, a raster printing form is made on which a gradation wedge is additionally placed to measure distortions caused by the printing technological processes. After that, a test print is made, the image is scanned and it is additionally corrected [10, 11]. For example, using the Gurnes software tool, the shape of the curve is selected on the monitor, based on which a corrected raster printing

plate is newly manufactured [12]. The presented additional procedures require significant time and material losses.

To replace additional image correction procedures, a coloring model has been developed that determines the ink amount on the surface of raster elements

$$V = S \cdot H,$$

where H – the relative thickness of the applied ink layer [3].

The nominal value of the thickness of the ink layer on the print depends on the type of ink and paper and for offset printing is within $0.7 \leq H_n \leq 1.2 \mu\text{m}$, and its average value is $H_c = 1.0 \mu\text{m}$ [13, 14]. Then the relative value of the thickness of the ink layer

$$H = \frac{0.7 \leq H_n \leq 1.2}{1.0}. \quad (11)$$

The thickness of the ink layer on the print significantly affects the quality of printed products, so modern ink machines are equipped with a multi-channel system for automatic adjustment of zonal ink supply for a given print run.

Based on the presented material and on the basis of mathematical expressions (1)–(11), a structural diagram of a simulator of the relative contrast of colored raster polynomially transformed digital images has been developed, which is presented in Fig. 1.

The R_{amp} and G_{ain} blocks form a linear scale L_0 , the value of which is a common input signal in the functional blocks $F_{cn} - F_{cn3}$. They contain programs (based on expressions (2)–(5)) of normalized polynomial transformation, in particular for digital images of light tones. The obtained output values $L_{n1} - L_{n4}$ are adjusted in the Gain blocks to the limit $0 \leq L_n \leq 1$, after which they are fed to the inputs of the functional blocks $F_{cn4} - F_{cn8}$. They contain programs (expressions (6)–(10)) of raster transformation $S_1 - S_4$ of light tones. The obtained raster transformation values are fed to the inputs of the Gain blocks, in which the relative thickness of the ink layer $H_1 - H_4$ on the surface of the raster elements is specified. The initial values of the gradation parameters (ink amount) $V_1 - V_4$ are fed to the first inputs (I_{n1}) of the Subsystem blocks, and the value of the coloration value V_0 of the linear scale is fed to the inputs (I_{n2}). In the Subsystem blocks, the relative contrasts $K_1 - K_4$ of the colored raster polynomially transformed digital image are calculated using expression (1), which are visualized in the Scope2 and Display1 blocks.

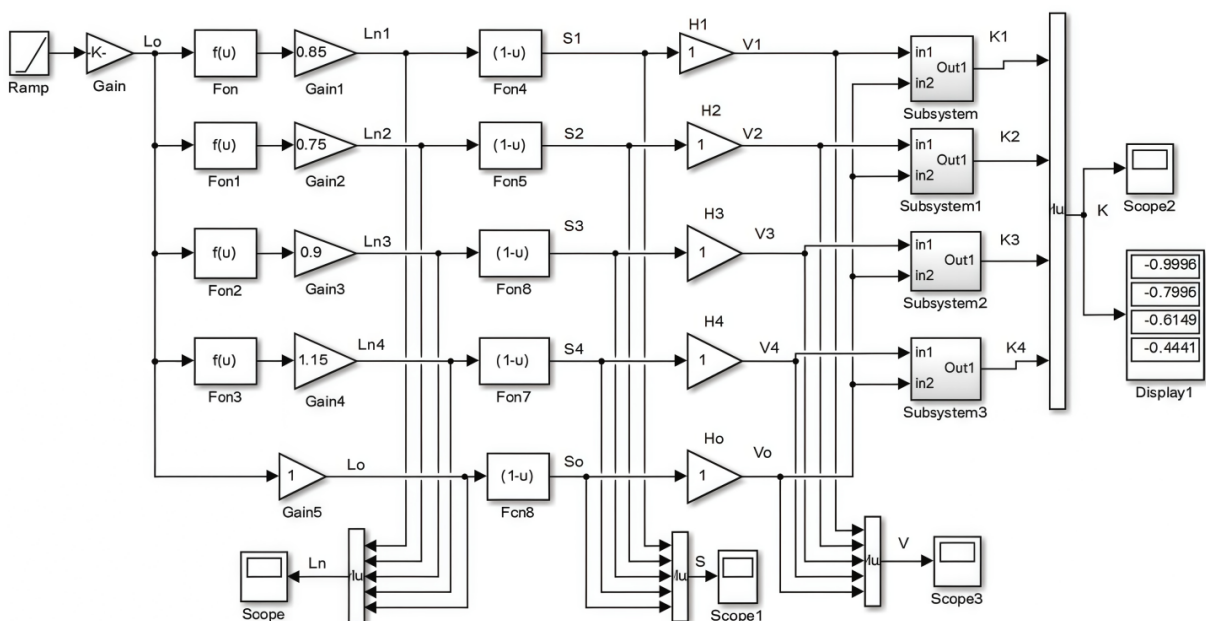

Fig. 1. Structural diagram of the simulator of contrast of colored raster polynomially transformed digital images

To conduct the research, in the functional blocks, the nominal value of the ink layer thickness $H = 1.0 \mu\text{m}$ was set.

It should be noted that the proposed simulator of the contrast of colored raster polynomially transformed digital images has the functionality to construct the gradation characteristics of the coloration of raster elements when changing the thickness of the ink layer. It also has the functionality to construct contrast characteristics of colored raster polynomially transformed digital images for different thicknesses of the ink layer. This allows to get interactive tools for effective adjustment of tone reproduction of digital images.

3.3. Construction of contrast characteristics of colored raster polynomially transformed images of different thicknesses of the ink layer

The results of modeling the process of coloring a raster image, in particular, in terms of constructing gradation characteristics of a digital image of light tones, when adjusting which a polynomial transformation was applied, are presented in Fig. 2 [3].

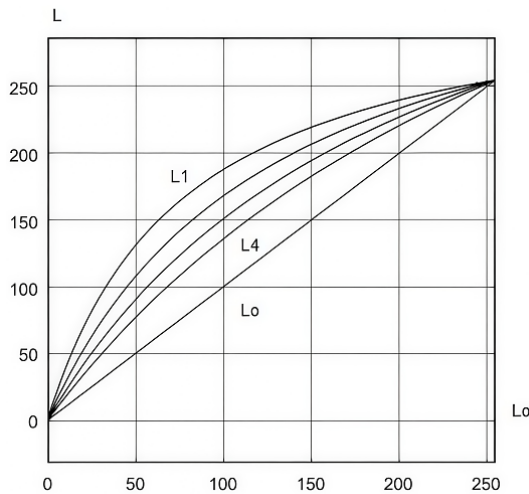

Fig. 2. Characteristics of the gradation distribution of polynomially transformed digital images

The linear gradation characteristic L_0 is located below. The characteristics of typical variants of polynomially transformed digital images are located above, which on the graphic plane (L_0-L_n) are elongated in the direction of light tones. Gradation characteristics are convex curves that have a large steepness at the beginning of the range, so dark areas of images are well distinguished. The steepness gradually decreases in the middle and light range, so light elements of images are well perceived.

The results of modeling the rasterization characteristics of typical variants of polynomially transformed digital images, in particular, raster transformation algorithms, are presented in Fig. 3 [3].

The top is the rasterization characteristic S_0 of the linear scale L_0 . The rasterization characteristics are concave descending curves, which on the graphic plane ($L_0 - S$) are elongated in the direction of small areas. The initial values of the relative areas are equal to 1, which on the graphic plane is in the region of dark tones. The rasterization characteristics decrease rapidly and at the same time their curvature decreases and they smoothly approach zero. The rasterization characteristics are the main carrier of information about the tonality of the image.

The results of modeling the relative contrast characteristics of colored raster polynomially transformed digital images for the nominal thickness of the ink layer $H_n = 1 \mu\text{m}$ are presented in Fig. 4.

The relative contrast is negative. The minus sign indicates that the coloring V_0 of the linear scale prevails over the coloring V_i . The initial

contrast values are zero, the characteristics are concave curves and gradually approach the final values: $K_4 = -0.413$, $K_3 = -0.572$, $K_2 = -0.745$, $K_1 = -0.933$ units. In this case, the coloring values V_1-V_4 are smaller than the linear coloring V_0 . Therefore, by reducing the coloring V_i , different contrast values are obtained. Using contrast, it is possible to improve the image quality by changing the contrast.

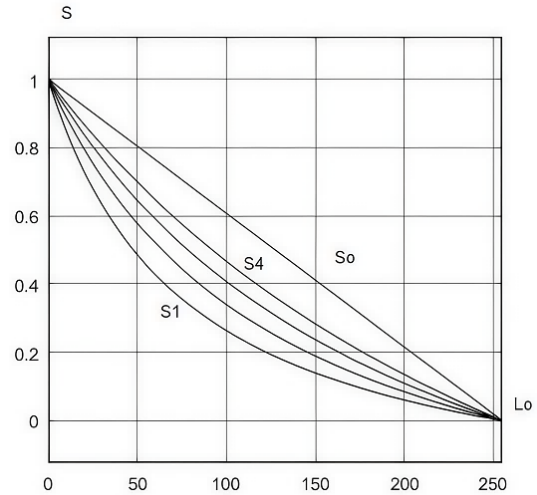

Fig. 3. Rasterization characteristics of digital images corrected using polynomial transformation

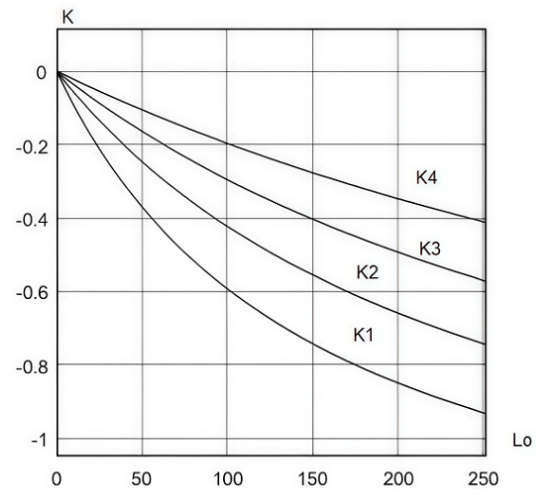

Fig. 4. Relative contrast characteristics of colored raster polynomially transformed digital images

In the course of the research, the influence of changing the thickness of the ink layer, at given raster element coloring coefficients, $V_1 = 1.2$, $V_2 = 1.0$, $V_3 = 0.80$, on the relative contrast of raster polynomially transformed digital images was considered.

The results of modeling the coloring of raster elements at different coloring coefficients (applying the thickness of the ink layer) are presented in Fig. 5.

The initial values of the coloring are: $V_1 = 1.2$, $V_2 = 1.0$, $V_3 = 0.80$ units, the characteristics are slightly concave curves compressed in the direction of decreasing the coloring, which gradually decrease and go to the final zero value. The initial curvature of the coloring characteristics is the largest, which gradually decreases and at the end of the interval is the smallest.

The results of modeling the characteristics of the relative contrast of colored raster polynomially transformed digital images at different coloring coefficients of raster elements (ink layer thickness) are presented in Fig. 6.

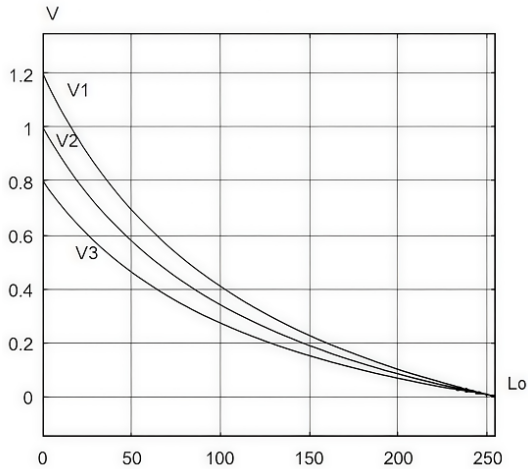

Fig. 5. Characteristics of the coloring of raster elements when changing the thickness of the ink layer

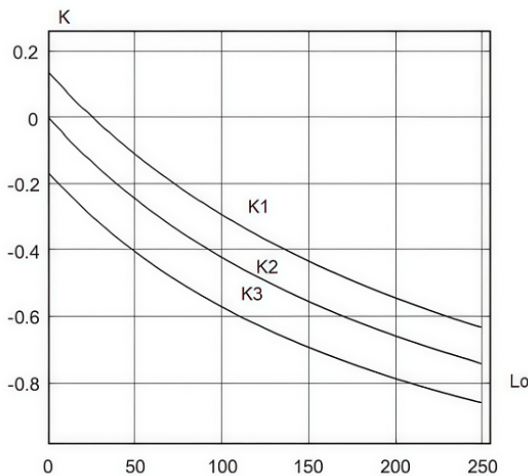

Fig. 6. Relative contrast characteristics of colored raster polynomially transformed digital images for different ink layer thickness

The initial values of relative contrast are: $K_1 = 0.2$, $K_2 = 0$, $K_3 = -0.2$ units. A negative value means that the coloring V_0 of the linear scale prevails over V_i . The contrast characteristics are concave curves and gradually approach the final values: $K_1 = -0.638$, $K_2 = -0.76$, $K_3 = -0.865$ units. Comparing the relative contrast characteristics for the nominal ink layer thickness $H_n = 1 \mu\text{m}$ (Fig. 4) with the contrast characteristics for different ink layer thicknesses, it is concluded that an increase in the ink layer thickness increases the initial contrast K_1 by 0.2 units. Reducing the thickness of the ink layer reduces the initial contrast K_3 by 0.2 units and reduces the final values of the contrasts. Therefore, by changing the thickness of the ink layer, it is possible to improve the image quality by changing the contrast.

The values of the obtained research results/relative contrast of polynomially transformed digital images and coloring of raster elements/are presented in Table 1.

Therefore, analyzing the research results, in particular the influence of coloring of raster elements on the relative contrast of the colored raster polynomially transformed image, a regular dependence of the contrast of the raster print on the thickness of the applied ink layer was established. In particular, when the thickness of the ink layer applied to the raster elements decreases, the relative contrast of the raster polynomially transformed image decreases, and vice versa, when the thickness of the ink layer applied to the raster elements increases, the relative contrast of the raster polynomially transformed image increases.

Table 1

Dependence of the relative contrast of colored polynomially transformed digital images on the coloring (thickness of the applied ink layer) of raster elements

Coloring (V)	Contrast (K) (initial values)			Contrast (K) (final values)		
	K_1	K_2	K_3	K_1	K_2	K_3
$V_1 (1.2) \uparrow$	0.2 \uparrow	-	-	-0.638 \uparrow	-	-
$V_2 (1.0)$	-	0	-	-	-0.76	-
$V_3 (0.8) \downarrow$	-	-	-0.2 \downarrow	-	-	-0.865 \downarrow

Notes: K – relative contrast of colored polynomially transformed digital images; V – coloring (thickness of the applied ink layer) of raster elements

3.4. Discussion

A model of coloring of raster elements has been developed to optimize the process of applying an ink layer, based on determining the contrast of raster polynomially transformed digital images of light tones. The basic components of the model are:

- developed variants of raster transformation of digital images, during the correction of which polynomial transformation was applied;
- developed a structural diagram of the simulator of the contrast of colored raster digital images, which are corrected based on the application of polynomial transformation;
- constructed gradation characteristics and characteristics of raster transformation of digital images, which are corrected using polynomial transformation;
- constructed graphs of the coloring of raster elements when changing the thickness of the ink layer and graphs of the relative contrast of colored raster polynomially transformed digital images for different thicknesses of the ink layer.

Each component of the model in the complex ensures the sequential execution of tasks:

1. To develop rasterization algorithms, based on the application of polynomial transformation, a raster transformation of digital images was carried out. As a result, a transformation was obtained to determine the relative area of raster elements, which are formed based on the dependence between the raster transformation and the amount of applied ink. This significantly expands the possibilities of pre-printing correction of digital images and determination of optimal values of the parameters of coloring of raster elements to ensure high-quality tone reproduction of the print.

2. To develop a simulator of the contrast of colored raster polynomially transformed digital images based on the proposed options for raster conversion of polynomially transformed digital images. The proposed simulator provides optimization of the process of pre-printing color correction based on the construction of the characteristics of coloring of raster elements and the characteristics of the contrast of colored raster polynomially transformed digital images.

3. The characteristics formed using the developed simulator provide determination of optimal coloring parameters (relative area of raster elements and amount of ink applied to raster elements) based on the determination of the contrast of raster polynomially transformed digital images. This provides an increase in the visual quality of the printed print.

Thus, the developed model of raster element coloring based on the definition of the contrast of raster digital images of light tones corrected using polynomial transformation has better characteristics compared to existing models. In particular, it makes it possible to optimize the process of raster element coloring in the context of determining the relationship between the image contrast and the amount of applied ink, which significantly increases the visual quality of images. At the same time, in the process of conducting research and based on the results obtained, it was established that the presented model describes

the influence of changing the thickness of the ink layer on the visual quality of the image due to changing its contrast. This makes it possible to conduct both qualitative and quantitative assessment of the visual quality of the print, in particular in the area of light tones.

Practical significance: The results of the conducted research, in particular the optimization of the coloring of raster elements, based on the determination of the contrast of raster polynomially transformed digital images, can be used in the processes of pre-print correction of digital images to improve the quality of tone reproduction, in particular:

- the use of the dependence of the contrast of polynomially transformed digital images and the coloring of raster elements allows the operator of computer publishing systems to form the characteristics of the coloring of raster elements and the characteristics of the contrast of colored raster polynomially transformed digital images. This makes it possible to optimize the pre-print process of correcting digital images in order to ensure high-quality tone reproduction of the print;
- the use of a method for improving the quality of tone reproduction based on the determination of the contrast of polynomially transformed digital images allows the operator of computer publishing systems to automatically calculate the coloring parameters (relative area of raster elements and the amount of applied ink). This ensures the optimal application of the thickness of the ink layer to obtain high-quality tone reproduction of the print.

Research limitations: The main limitations of the research are that the application of the proposed method for improving the quality of tone reproduction requires an appropriate algorithm for the functional interaction of the operator – software and hardware – coloring system. This approach provides the reproduction of raster tones using the dependence between the area of raster elements and the ink amount applied to them and, accordingly, the formation of their optimal values based on determining the contrast of polynomially transformed digital images.

Prospects for further research: The research results are the basis for the formation of new approaches to ensuring the quality of tone reproduction, in particular, based on determining the optical density of the print and establishing a dependence on the process of coloring raster elements. At the same time, further research can be focused on improving the proposed model based on optimizing the process of pre-printing correction of digital images and tone transmission.

4. Conclusions

1. Algorithms for rasterizing digital images of light tones, corrected with the suction of polynomial transformation, have been developed. Based on the obtained mathematical dependencies, the influence of changing the relative contrast of a colored polynomially transformed digital image on changing the thickness of the applied ink layer is described. The obtained expressions for determining the value of the relative area of raster elements are a rasterization algorithm. It has been established that changing the thickness of the ink layer can affect the image quality by changing the contrast.

The development of algorithms for rasterizing polynomially transformed digital images formed the basis for determining the patterns of the influence of the contrast of colored polynomially transformed digital images on the coloring of raster elements.

2. A structural diagram of a simulator of the contrast of colored raster digital images of light tones, corrected with the use of polynomial transformation, has been constructed. Based on the proposed simulator, interactive tools for simulation modeling of raster element coloring based on determining the relative contrast of a colored polynomially transformed digital image were obtained.

The construction of a simulator of contrast of colored raster polynomially transformed digital images provides the functionality of constructing gradation characteristics of raster element coloring when

changing the thickness of the ink layer and the characteristics of contrast of colored raster polynomially transformed digital images for different thicknesses of the ink layer.

The use of the proposed model of raster element coloring based on determining the relative contrast of colored polynomially transformed digital images optimizes the process of applying an ink layer. This allows to improve the quality of the printed print, reduce product defects and achieve savings in the use of printing materials.

3. The characteristics of the coloring of raster elements when changing the thickness of the ink layer and the characteristics of the contrast of the colored raster polynomially transformed digital images for different thicknesses of the ink layer were calculated and constructed. The formed characteristics make it possible to determine the optimal coloring parameters (the relative area of the raster elements and the ink amount applied to the raster elements), which ensures high-quality tone reproduction of images. It is proved that when changing the coloring (increasing/decreasing the thickness of the ink layer) the initial values of the relative contrast are: $K_1 = 0.2$, $K_2 = 0$, $K_3 = -0.2$ units, and the final values are: $K_1 = -0.638$, $K_2 = -0.76$, $K_3 = -0.865$ units. The revealed regularity between the change in the relative contrast of colored raster polynomially transformed digital images and the change in the thickness of the ink layer formed the basis of recommendations for improving the quality of image tone reproduction in the process of raster tone transfer.

Conflict of interest

The authors declare that they have no conflict of interest regarding this research, including financial, personal, authorship or other nature, which could affect the research and its results presented in this article.

Financing

The research was conducted without financial support.

Data availability

The manuscript has no associated data.

Use of artificial intelligence

The authors confirm that they did not use artificial intelligence technologies when creating the presented work.

Authors' contributions

Sviatoslav Kavyn: Conceptualization, Methodology, Software, Formal analysis, Investigation, Validation, Data curation, Writing – original draft, Writing – review and editing; **Bohdan Kavyn:** Conceptualization, Methodology, Software, Formal analysis, Investigation, Validation, Data curation, Writing – original draft, Writing – review and editing.

References

1. Vorobel, R. A. (2012). *Loharyfnichna obrobka zobrazen*. Kyiv: Naukovo-vyrobnyche pidpryemstvo "Vydavnytstvo "Naukova dumka" NAN Ukrainy", 322.
2. Lutskiv, M. M. (2012). *Tsyfrovii tekhnolohii drukarstva*. Lviv: UAD, 480.
3. Kavyn, B. (2025). Development of a model for coloring raster elements of polynomial transformation of digital images. *Technology Audit and Production Reserves*, 2 (2 (82)), 27–31. <https://doi.org/10.15587/2706-5448.2025.323533>
4. Gonzales, R. C., Woods, R. E. (2018). *Digital image processing: international Version 4 Edition*. Pearson, 1104. Available at: <https://www.cl72.org/090imagePLib/books/GonzalesWoods-Digital.Image.Processing.4th.Edition.pdf>
5. Umbaugh, S. E. (2022). *Digital Image Processing and Analysis*. CRC Press, 488. <https://doi.org/10.1201/9781003221135>

6. Kavyn, S. (2025). Development of a model of raster power-linear conversion of digital images of light tones. *Technology Audit and Production Reserves*, 4 (2 (84)), 60–64. <https://doi.org/10.15587/2706-5448.2025.337277>
7. Durnyak, B., Lutskiv, M., Shepita, P., Hunko, D., Savina, N. (2021). Formation of liner Characteristics of Normalized Roster Trans Formation for Rombic Elemtnts. *Intelligent Information Technologies & System of Information Security. CEUR Workshop Proceedings*, 2853, 127–133. Available at: <https://ceur-ws.org/Vol-2853/short10.pdf>
8. Blanchet, G., Charbit, M. (2015). *Digital Signal and Image Processing Using Matlab: Vol. 2, Advances and applications: The Deterministic Case*. ISTE Ltd and John Wiley & Sons Inc, 287. <https://doi.org/10.1002/9781118999592>
9. Bredies, K., Lorenz, D. (2018). *Mathematical Image Processing. Applied and Numerical Harmonic Analysis*. Springer International Publishing, 473. <https://doi.org/10.1007/978-3-030-01458-2>
10. Kovalskiy, B., Semeniv, M., Shovgenyuk, M. (2016). Computer program for the image synthesis on impress for the new information and traditional technologies of color printing. *Science and Education a New Dimention: Natural and Technical Science, IV (10 (91))*, 72–78.
11. Durniak, B. V., Senkivskiy, V. M., Lutskiv, M. M., Musiiovska, M. M. (2021). *Informatsiina tekhnolohiia tonovidtvorennia v korotkykh farbodrukarskykh systemakh poslidovnoi struktury*. Lviv: UAD, 176.
12. Distant, A., Distant, C. (2020). *Handbook of Image Processing and Computer Vision*. Springer International Publishing, 432. <https://doi.org/10.1007/978-3-030-42374-2>
13. Durnyak, B., Lutskiv, M., Shepita, P., Karpyn, R., Savina, N. (2021). Determination of the Optical Density of Two-Parameter Tone Transfer for a Short Printing System of the Sixth Dimension. *Intelligent International Technologies & Systems of Information Security: CEUR Workshop Proceedings*, 2853, 134–140. Available at: <https://ceur-ws.org/Vol-2853/short11.pdf>
14. Lutskiv, M., Fedyna, B., Nakonechnyi, M. (2025). Simulation of tone reproduction of digital rast images with change of paint thickness. *Technological Complexes*, 17 (1), 30–40. <https://doi.org/10.36910/4293-52779-2025-17-01-03>

✉ **Sviatoslav Kavyn**, Doctor of Philosophy (PhD), Assistant, Department of Computer Technologies in Publishing and Printing Processes, Lviv Polytechnic National University, Lviv, Ukraine, e-mail: kavinsviatoslav@gmail.com, ORCID: <https://orcid.org/0000-0002-6189-3848>

Bohdan Kavyn, PhD Student, Department of Computer Technologies in Publishing and Printing Processes, Lviv Polytechnic National University, Lviv, Ukraine, ORCID: <https://orcid.org/0009-0004-6553-1061>

✉ Corresponding author